

A
EC
C
D
E
F
G
H
I
J
K
L
M

SECTION EC

ENGINE CONTROL SYSTEM

CONTENTS

VQ35DE	
INDEX FOR DTC	15
Alphabetical Index	15
DTC No. Index	19
PRECAUTIONS	23
Precautions for Supplemental Restraint System (SRS) "AIR BAG" and "SEAT BELT PRE-TENSIONER"	23
On Board Diagnostic (OBD) System of Engine and A/T	23
Precaution	23
Wiring Diagrams and Trouble Diagnosis	26
PREPARATION	27
Special Service Tools	27
Commercial Service Tools	28
ENGINE CONTROL SYSTEM	29
System Diagram	29
Vacuum Hose Drawing	30
System Chart	31
Multiport Fuel Injection (MFI) System	32
Electronic Ignition (EI) System	34
Air Conditioning Cut Control	35
Fuel Cut Control (at No Load and High Engine Speed)	35
CAN communication	36
BASIC SERVICE PROCEDURE	37
Idle Speed and Ignition Timing Check	37
Idle Speed/Ignition Timing/Idle Mixture Ratio Adjustment	38
Accelerator Pedal Released Position Learning	49
Throttle Valve Closed Position Learning	49
Idle Air Volume Learning	49
Fuel Pressure Check	51
ON BOARD DIAGNOSTIC (OBD) SYSTEM	53
Introduction	53
Two Trip Detection Logic	53
Emission-Related Diagnostic Information	54
IVIS (Infiniti Vehicle Immobilizer System — NATS)	68
Malfunction Indicator Lamp (MIL)	68
OBD System Operation Chart	72
TROUBLE DIAGNOSIS	77
Trouble Diagnosis Introduction	77
DTC Inspection Priority Chart	80
Fail-Safe Chart	82
Basic Inspection	83
Symptom Matrix Chart	88
Engine Control Component Parts Location	92
Circuit Diagram	98
ECM Harness Connector Terminal Layout	100
ECM Terminals and Reference Value	100
CONSULT-II Function	109
Generic Scan Tool (GST) Function	122
CONSULT-II Reference Value in Data Monitor	125
Major Sensor Reference Graph in Data Monitor Mode	129
TROUBLE DIAGNOSIS - SPECIFICATION VALUE	131
Description	131
Testing Condition	131
Inspection Procedure	131
Diagnostic Procedure	132
TROUBLE DIAGNOSIS FOR INTERMITTENT INCIDENT	135
Description	135
Diagnostic Procedure	135
POWER SUPPLY AND GROUND CIRCUIT	136
Wiring Diagram	136
Diagnostic Procedure	137
Ground Inspection	141
DTC U1000, U1001 CAN COMMUNICATION LINE	142
Description	142
On Board Diagnosis Logic	142
DTC Confirmation Procedure	142
Wiring Diagram	143
Diagnostic Procedure	144
DTC P0011, P0021 IVT CONTROL	145
Description	145
CONSULT-II Reference Value in Data Monitor Mode	145
On Board Diagnosis Logic	146

DTC Confirmation Procedure	146	DTC P0122, P0123 TP SENSOR	190
Diagnostic Procedure	148	Component Description	190
DTC P0031, P0032, P0051, P0052 HO2S1 HEATER 149		CONSULT-II Reference Value in Data Monitor Mode	190
Description	149	On Board Diagnosis Logic	190
CONSULT-II Reference Value in Data Monitor Mode	149	DTC Confirmation Procedure	191
On Board Diagnosis Logic	149	Wiring Diagram	192
DTC Confirmation Procedure	150	Diagnostic Procedure	193
Wiring Diagram	151	Component Inspection	196
Diagnostic Procedure	154	Removal and Installation	196
Component Inspection	156	DTC P0125 ECT SENSOR	197
Removal and Installation	156	Component Description	197
DTC P0037, P0038, P0057, P0058 HO2S2 HEATER 157		On Board Diagnosis Logic	197
Description	157	DTC Confirmation Procedure	198
CONSULT-II Reference Value in Data Monitor Mode	157	Diagnostic Procedure	198
On Board Diagnosis Logic	157	Component Inspection	199
DTC Confirmation Procedure	158	Removal and Installation	199
Wiring Diagram	159	DTC P0127 IAT SENSOR	200
Diagnostic Procedure	162	Component Description	200
Component Inspection	164	On Board Diagnosis Logic	200
Removal and Installation	164	DTC Confirmation Procedure	200
DTC P0101 MAF SENSOR	165	Diagnostic Procedure	201
Component Description	165	Component Inspection	202
CONSULT-II Reference Value in Data Monitor Mode	165	Removal and Installation	202
On Board Diagnosis Logic	165	DTC P0128 THERMOSTAT FUNCTION	203
DTC Confirmation Procedure	166	On Board Diagnosis Logic	203
Overall Function Check	167	DTC Confirmation Procedure	203
Wiring Diagram	168	Diagnostic Procedure	203
Diagnostic Procedure	169	Component Inspection	204
Component Inspection	172	Removal and Installation	204
Removal and Installation	172	DTC P0132, P0152 HO2S1	205
DTC P0102, P0103 MAF SENSOR	173	Component Description	205
Component Description	173	CONSULT-II Reference Value in Data Monitor Mode	205
CONSULT-II Reference Value in Data Monitor Mode	173	On Board Diagnosis Logic	205
On Board Diagnosis Logic	173	DTC Confirmation Procedure	206
DTC Confirmation Procedure	174	Wiring Diagram	207
Wiring Diagram	175	Diagnostic Procedure	210
Diagnostic Procedure	176	Component Inspection	212
Component Inspection	179	Removal and Installation	213
Removal and Installation	179	DTC P0133, P0153 HO2S1	214
DTC P0112, P0113 IAT SENSOR	180	Component Description	214
Component Description	180	CONSULT-II Reference Value in Data Monitor Mode	214
On Board Diagnosis Logic	180	On Board Diagnosis Logic	214
DTC Confirmation Procedure	180	DTC Confirmation Procedure	215
Wiring Diagram	182	Overall Function Check	216
Diagnostic Procedure	183	Wiring Diagram	217
Component Inspection	184	Diagnostic Procedure	220
Removal and Installation	184	Component Inspection	224
DTC P0117, P0118 ECT SENSOR	185	Removal and Installation	225
Component Description	185	DTC P0134, P0154 HO2S1	226
On Board Diagnosis Logic	185	Component Description	226
DTC Confirmation Procedure	186	CONSULT-II Reference Value in Data Monitor Mode	226
Wiring Diagram	187	On Board Diagnosis Logic	226
Diagnostic Procedure	188	DTC Confirmation Procedure	227
Component Inspection	189	Overall Function Check	228
Removal and Installation	189	Wiring Diagram	229

Diagnostic Procedure	232	Diagnostic Procedure	287
Component Inspection	234	Component Inspection	290
Removal and Installation	235	Removal and Installation	290
DTC P0138, P0158 HO2S2	236	DTC P0300 - P0306 MULTIPLE CYLINDER MIS-	
Component Description	236	FIRE, NO. 1 - 6 CYLINDER MISFIRE	291
CONSULT-II Reference Value in Data Monitor Mode		On Board Diagnosis Logic	291
	236	DTC Confirmation Procedure	291
On Board Diagnosis Logic	236	Diagnostic Procedure	292
DTC Confirmation Procedure	237	DTC P0327, P0328 KS	297
Wiring Diagram	238	Component Description	297
Diagnostic Procedure	241	On Board Diagnosis Logic	297
Component Inspection	243	DTC Confirmation Procedure	297
Removal and Installation	244	Wiring Diagram	298
DTC P0139, P0159 HO2S2	245	Diagnostic Procedure	299
Component Description	245	Component Inspection	300
CONSULT-II Reference Value in Data Monitor Mode		Removal and Installation	301
	245	DTC P0335 CKP SENSOR (POS)	302
On Board Diagnosis Logic	245	Component Description	302
DTC Confirmation Procedure	246	CONSULT-II Reference Value in Data Monitor Mode	
Overall Function Check	246		302
Wiring Diagram	248	On Board Diagnosis Logic	302
Diagnostic Procedure	251	DTC Confirmation Procedure	302
Component Inspection	253	Wiring Diagram	303
Removal and Installation	255	Diagnostic Procedure	304
DTC P0171, P0174 FUEL INJECTION SYSTEM		Component Inspection	307
FUNCTION	256	Removal and Installation	307
On Board Diagnosis Logic	256	DTC P0340, P0345 CMP SENSOR (PHASE)	308
DTC Confirmation Procedure	256	Component Description	308
Wiring Diagram	258	CONSULT-II Reference Value in Data Monitor Mode	
Diagnostic Procedure	260		308
DTC P0172, P0175 FUEL INJECTION SYSTEM		On Board Diagnosis Logic	308
FUNCTION	265	DTC Confirmation Procedure	308
On Board Diagnosis Logic	265	Wiring Diagram	309
DTC Confirmation Procedure	265	Diagnostic Procedure	312
Wiring Diagram	267	Component Inspection	315
Diagnostic Procedure	269	Removal and Installation	315
DTC P0181 FTT SENSOR	273	DTC P0420, P0430 THREE WAY CATALYST FUNC-	
Component Description	273	TION	316
On Board Diagnosis Logic	273	On Board Diagnosis Logic	316
DTC Confirmation Procedure	273	DTC Confirmation Procedure	316
Wiring Diagram	275	Overall Function Check	317
Diagnostic Procedure	276	Diagnostic Procedure	318
Component Inspection	277	DTC P0441 EVAP CONTROL SYSTEM	321
Removal and Installation	278	System Description	321
DTC P0182, P0183 FTT SENSOR	279	On Board Diagnosis Logic	321
Component Description	279	DTC Confirmation Procedure	321
On Board Diagnosis Logic	279	Overall Function Check	322
DTC Confirmation Procedure	279	Diagnostic Procedure	323
Wiring Diagram	280	DTC P0442 EVAP CONTROL SYSTEM	326
Diagnostic Procedure	281	On Board Diagnosis Logic	326
Component Inspection	282	DTC Confirmation Procedure	327
Removal and Installation	283	Diagnostic Procedure	328
DTC P0222, P0223 TP SENSOR	284	DTC P0444, P0445 EVAP CANISTER PURGE VOL-	
Component Description	284	UME CONTROL SOLENOID VALVE	335
CONSULT-II Reference Value in Data Monitor Mode		Description	335
	284	CONSULT-II Reference Value in Data Monitor Mode	
On Board Diagnosis Logic	284		335
DTC Confirmation Procedure	285	On Board Diagnosis Logic	336
Wiring Diagram	286	DTC Confirmation Procedure	336

Wiring Diagram	337	DTC P0461 FUEL LEVEL SENSOR	386
Diagnostic Procedure	339	Component Description	386
Component Inspection	340	On Board Diagnosis Logic	386
Removal and Installation	341	Overall Function Check	386
DTC P0447 EVAP CANISTER VENT CONTROL		Diagnostic Procedure	387
VALVE	342	Removal and Installation	387
Component Description	342	DTC P0462, P0463 FUEL LEVEL SENSOR	388
CONSULT-II Reference Value in Data Monitor Mode		Component Description	388
	342	On Board Diagnosis Logic	388
On Board Diagnosis Logic	342	DTC Confirmation Procedure	388
DTC Confirmation Procedure	343	Diagnostic Procedure	389
Wiring Diagram	344	Removal and Installation	389
Diagnostic Procedure	345	DTC P0500 VSS	390
Component Inspection	347	Description	390
DTC P0451 EVAP CONTROL SYSTEM PRESSURE		On Board Diagnosis Logic	390
SENSOR	349	DTC Confirmation Procedure	390
Component Description	349	Overall Function Check	390
CONSULT-II Reference Value in Data Monitor Mode		Diagnostic Procedure	391
	349	DTC P0506 ISC SYSTEM	392
On Board Diagnosis Logic	349	Description	392
DTC Confirmation Procedure	350	On Board Diagnosis Logic	392
Diagnostic Procedure	350	DTC Confirmation Procedure	392
Component Inspection	351	Diagnostic Procedure	393
DTC P0452 EVAP CONTROL SYSTEM PRESSURE		DTC P0507 ISC SYSTEM	394
SENSOR	352	Description	394
Component Description	352	On Board Diagnosis Logic	394
CONSULT-II Reference Value in Data Monitor Mode		DTC Confirmation Procedure	394
	352	Diagnostic Procedure	395
On Board Diagnosis Logic	352	DTC P0550 PSP SENSOR	396
DTC Confirmation Procedure	353	Component Description	396
Wiring Diagram	354	CONSULT-II Reference Value in Data Monitor Mode	
Diagnostic Procedure	355		396
Component Inspection	357	On Board Diagnosis Logic	396
DTC P0453 EVAP CONTROL SYSTEM PRESSURE		DTC Confirmation Procedure	396
SENSOR	358	Wiring Diagram	397
Component Description	358	Diagnostic Procedure	398
CONSULT-II Reference Value in Data Monitor Mode		Component Inspection	400
	358	Removal and Installation	400
On Board Diagnosis Logic	358	DTC P0605 ECM	401
DTC Confirmation Procedure	359	Component Description	401
Wiring Diagram	360	On Board Diagnosis Logic	401
Diagnostic Procedure	361	DTC Confirmation Procedure	401
Component Inspection	365	Diagnostic Procedure	402
DTC P0455 EVAP CONTROL SYSTEM	366	DTC P1065 ECM POWER SUPPLY	404
On Board Diagnosis Logic	366	Component Description	404
DTC Confirmation Procedure	367	On Board Diagnosis Logic	404
Diagnostic Procedure	368	DTC Confirmation Procedure	404
DTC P0456 EVAP CONTROL SYSTEM	374	Wiring Diagram	405
On Board Diagnosis Logic	374	Diagnostic Procedure	406
DTC Confirmation Procedure	375	DTC P1111, P1136 IVT CONTROL SOLENOID	
Overall Function Check	376	VALVE	408
Diagnostic Procedure	377	Component Description	408
DTC P0460 FUEL LEVEL SENSOR	384	CONSULT-II Reference Value in Data Monitor Mode	
Component Description	384		408
On Board Diagnosis Logic	384	On Board Diagnosis Logic	408
DTC Confirmation Procedure	384	DTC Confirmation Procedure	408
Diagnostic Procedure	385	Wiring Diagram	409
Removal and Installation	385	Diagnostic Procedure	412

Component Inspection	414	DTC Confirmation Procedure	447	
Removal and Installation	414	Overall Function Check	447	A
DTC P1121 ELECTRIC THROTTLE CONTROL		Wiring Diagram	449	
ACTUATOR	415	Diagnostic Procedure	452	
Component Description	415	Component Inspection	454	EC
On Board Diagnosis Logic	415	Removal and Installation	456	
DTC Confirmation Procedure	415	DTC P1147, P1167 HO2S2	457	
Diagnostic Procedure	416	Component Description	457	C
DTC P1122 ELECTRIC THROTTLE CONTROL		CONSULT-II Reference Value in Data Monitor Mode	457	
FUNCTION	417	On Board Diagnosis Logic	457	
Description	417	DTC Confirmation Procedure	458	D
On Board Diagnosis Logic	417	Overall Function Check	458	
DTC Confirmation Procedure	417	Wiring Diagram	460	
Wiring Diagram	418	Diagnostic Procedure	463	E
Diagnostic Procedure	419	Component Inspection	465	
Component Inspection	422	Removal and Installation	467	
Removal and Installation	422	DTC P1148, P1168 CLOSED LOOP CONTROL ...	468	F
DTC P1124, P1126 THROTTLE CONTROL MOTOR		On Board Diagnosis Logic	468	
RELAY	423	DTC Confirmation Procedure	468	
Component Description	423	Overall Function Check	468	
CONSULT-II Reference Value in Data Monitor Mode	423	Diagnostic Procedure	469	G
On Board Diagnosis Logic	423	DTC P1211 TCS CONTROL UNIT	470	
DTC Confirmation Procedure	423	Description	470	
Wiring Diagram	425	On Board Diagnosis Logic	470	H
Diagnostic Procedure	426	DTC Confirmation Procedure	470	
DTC P1128 THROTTLE CONTROL MOTOR	428	Diagnostic Procedure	470	
Component Description	428	DTC P1212 TCS COMMUNICATION LINE	471	I
On Board Diagnosis Logic	428	Description	471	
DTC Confirmation Procedure	428	On Board Diagnosis Logic	471	
Wiring Diagram	429	DTC Confirmation Procedure	471	J
Diagnostic Procedure	430	Diagnostic Procedure	471	
Component Inspection	431	DTC P1217 ENGINE OVER TEMPERATURE	472	
Removal and Installation	432	Description	472	
DTC P1143, P1163 HO2S1	433	CONSULT-II Reference Value in Data Monitor Mode	475	K
Component Description	433	On Board Diagnosis Logic	475	
CONSULT-II Reference Value in Data Monitor Mode	433	Overall Function Check	475	
On Board Diagnosis Logic	433	Wiring Diagram	477	L
DTC Confirmation Procedure	434	Diagnostic Procedure	479	
Overall Function Check	435	Main 12 Causes of Overheating	484	
Diagnostic Procedure	435	Component Inspection	484	M
Component Inspection	437	DTC P1225 TP SENSOR	485	
Removal and Installation	438	Component Description	485	
DTC P1144, P1164 HO2S1	439	On Board Diagnosis Logic	485	
Component Description	439	DTC Confirmation Procedure	485	
CONSULT-II Reference Value in Data Monitor Mode	439	Diagnostic Procedure	486	
On Board Diagnosis Logic	439	Removal and Installation	486	
DTC Confirmation Procedure	440	DTC P1226 TP SENSOR	487	
Overall Function Check	441	Component Description	487	
Diagnostic Procedure	441	On Board Diagnosis Logic	487	
Component Inspection	443	DTC Confirmation Procedure	487	
Removal and Installation	445	Diagnostic Procedure	488	
DTC P1146, P1166 HO2S2	446	Removal and Installation	488	
Component Description	446	DTC P1229 SENSOR POWER SUPPLY	489	
CONSULT-II Reference Value in Data Monitor Mode	446	On Board Diagnosis Logic	489	
On Board Diagnosis Logic	446	DTC Confirmation Procedure	489	
		Wiring Diagram	490	
		Diagnostic Procedure	491	

DTC P1444 EVAP CANISTER PURGE VOLUME CONTROL SOLENOID VALVE	494	Diagnostic Procedure	535
Description	494	Component Inspection	540
CONSULT-II Reference Value in Data Monitor Mode	494	DTC P1574 ICC VEHICLE SPEED SENSOR	541
On Board Diagnosis Logic	495	Component Description	541
DTC Confirmation Procedure	495	On Board Diagnosis Logic	541
Wiring Diagram	496	DTC Confirmation Procedure	541
Diagnostic Procedure	498	Diagnostic Procedure	542
Component Inspection	501	DTC P1574 ASCD VEHICLE SPEED SENSOR	543
Removal and Installation	501	Component Description	543
DTC P1446 EVAP CANISTER VENT CONTROL VALVE	502	On Board Diagnosis Logic	543
Component Description	502	DTC Confirmation Procedure	543
CONSULT-II Reference Value in Data Monitor Mode	502	Diagnostic Procedure	544
On Board Diagnosis Logic	502	DTC P1706 PNP SWITCH	545
DTC Confirmation Procedure	503	Component Description	545
Wiring Diagram	504	CONSULT-II Reference Value in Data Monitor Mode	545
Diagnostic Procedure	505	On Board Diagnosis Logic	545
Component Inspection	506	DTC Confirmation Procedure	545
DTC P1564 ICC STEERING SWITCH	508	Overall Function Check	546
Component Description	508	Wiring Diagram	547
CONSULT-II Reference Value in Data Monitor Mode	508	Diagnostic Procedure	548
On Board Diagnosis Logic	508	DTC P1805 BRAKE SWITCH	550
DTC Confirmation Procedure	508	Description	550
Wiring Diagram	510	CONSULT-II Reference Value in Data Monitor Mode	550
Diagnostic Procedure	511	On Board Diagnosis Logic	550
Component Inspection	514	DTC Confirmation Procedure	550
DTC P1564 ASCD STEERING SWITCH	515	Wiring Diagram	551
Component Description	515	Diagnostic Procedure	552
CONSULT-II Reference Value in Data Monitor Mode	515	Component Inspection	554
On Board Diagnosis Logic	515	DTC P2122, P2123 APP SENSOR	555
DTC Confirmation Procedure	516	Component Description	555
Wiring Diagram	517	CONSULT-II Reference Value in Data Monitor Mode	555
Diagnostic Procedure	518	On Board Diagnosis Logic	555
Component Inspection	520	DTC Confirmation Procedure	556
DTC P1568 ICC FUNCTION	521	Wiring Diagram	557
On Board Diagnosis Logic	521	Diagnostic Procedure	558
DTC Confirmation Procedure	521	Component Inspection	560
Diagnostic Procedure	521	Removal and Installation	561
DTC P1572 ICC BRAKE SWITCH	522	DTC P2127, P2128 APP SENSOR	562
Component Description	522	Component Description	562
CONSULT-II Reference Value in Data Monitor Mode	522	CONSULT-II Reference Value in Data Monitor Mode	562
On Board Diagnosis Logic	522	On Board Diagnosis Logic	562
DTC Confirmation Procedure	523	DTC Confirmation Procedure	563
Wiring Diagram	524	Wiring Diagram	564
Diagnostic Procedure	525	Diagnostic Procedure	565
Component Inspection	530	Component Inspection	568
DTC P1572 ASCD BRAKE SWITCH	532	Removal and Installation	568
Component Description	532	DTC P2135 TP SENSOR	569
CONSULT-II Reference Value in Data Monitor Mode	532	Component Description	569
On Board Diagnosis Logic	532	CONSULT-II Reference Value in Data Monitor Mode	569
DTC Confirmation Procedure	533	On Board Diagnosis Logic	569
Wiring Diagram	534	DTC Confirmation Procedure	570
		Wiring Diagram	571
		Diagnostic Procedure	572

Component Inspection	575	ASCD INDICATOR	632	A
Removal and Installation	575	Component Description	632	
DTC P2138 APP SENSOR	576	CONSULT-II Reference Value in Data Monitor Mode	632	
Component Description	576	Wiring Diagram	633	EC
CONSULT-II Reference Value in Data Monitor Mode	576	Diagnostic Procedure	634	
On Board Diagnosis Logic	576	SNOW MODE SWITCH	635	C
DTC Confirmation Procedure	577	Description	635	
Wiring Diagram	578	CONSULT-II Reference Value in the Data Monitor Mode	635	
Diagnostic Procedure	579	Wiring Diagram	636	D
Component Inspection	584	Diagnostic Procedure	637	
Removal and Installation	584	Component Inspection	640	
IGNITION SIGNAL	585	MIL AND DATA LINK CONNECTOR	641	E
Component Description	585	Wiring Diagram	641	
Wiring Diagram	586	EVAPORATIVE EMISSION SYSTEM	643	F
Diagnostic Procedure	591	Description	643	
Component Inspection	595	Component Inspection	646	
Removal and Installation	596	Removal and Installation	647	
INJECTOR CIRCUIT	597	How to Detect Fuel Vapor Leakage	647	G
Component Description	597	ON BOARD REFUELING VAPOR RECOVERY (ORVR)	650	
CONSULT-II Reference Value in Data Monitor Mode	597	System Description	650	
Wiring Diagram	598	Diagnostic Procedure	651	H
Diagnostic Procedure	599	Component Inspection	653	
Component Inspection	602	POSITIVE CRANKCASE VENTILATION	655	I
Removal and Installation	602	Description	655	
FUEL PUMP CIRCUIT	603	Component Inspection	655	J
Description	603	AUTOMATIC SPEED CONTROL DEVICE (ASCD)	657	
CONSULT-II Reference Value in Data Monitor Mode	603	System Description	657	
Wiring Diagram	604	Component Description	659	K
Diagnostic Procedure	605	SERVICE DATA AND SPECIFICATIONS (SDS) ...	660	
Component Inspection	608	Fuel Pressure	660	
Removal and Installation	608	Idle Speed and Ignition Timing	660	
REFRIGERANT PRESSURE SENSOR	609	Calculated Load Value	660	
Component Description	609	Mass Air Flow Sensor	660	
Wiring Diagram	610	Intake Air Temperature Sensor	660	
Diagnostic Procedure	611	Engine Coolant Temperature Sensor	660	L
Removal and Installation	613	Heated Oxygen Sensor 1 Heater	660	
ELECTRICAL LOAD SIGNAL	614	Heated Oxygen sensor 2 Heater	660	
Description	614	Crankshaft Position Sensor (POS)	660	M
CONSULT-II Reference Value in Data Monitor Mode	614	Camshaft Position Sensor (PHASE)	660	
Diagnostic Procedure	614	Throttle Control Motor	660	
ICC BRAKE SWITCH	615	Injector	661	
Component Description	615	Fuel Pump	661	
CONSULT-II Reference Value in Data Monitor Mode	615			
Wiring Diagram	616			
Diagnostic Procedure	617			
Component Inspection	622			
ASCD BRAKE SWITCH	624			
Component Description	624			
CONSULT-II Reference Value in Data Monitor Mode	624			
Wiring Diagram	625			
Diagnostic Procedure	626			
Component Inspection	631			
		VK45DE		
		INDEX FOR DTC	662	
		Alphabetical Index	662	
		DTC No. Index	665	
		PRECAUTIONS	670	
		Precautions for Supplemental Restraint System (SRS) "AIR BAG" and "SEAT BELT PRE-TENSIONER"	670	
		On Board Diagnostic (OBD) System of Engine and A/T	670	
		Precaution	670	
		Wiring Diagrams and Trouble Diagnosis	673	

PREPARATION	674	On Board Diagnosis Logic	792
Special Service Tools	674	DTC Confirmation Procedure	792
Commercial Service Tools	675	Wiring Diagram	793
ENGINE CONTROL SYSTEM	676	Diagnostic Procedure	794
System Diagram	676	DTC P0011, P0021 IVT CONTROL	795
Vacuum Hose Drawing	677	Description	795
System Chart	678	CONSULT-II Reference Value in Data Monitor Mode	796
Multiport Fuel Injection (MFI) System	679	On Board Diagnosis Logic	796
Electronic Ignition (EI) System	681	DTC Confirmation Procedure	797
Nissan Torque Demand (NTD) Control System	682	Wiring Diagram	798
Air Conditioning Cut Control	683	Diagnostic Procedure	801
Fuel Cut Control (at No Load and High Engine Speed)	683	Component Inspection	805
CAN communication	684	Removal and Installation	805
BASIC SERVICE PROCEDURE	685	DTC P0031, P0032, P0051, P0052 HO2S1 HEATER	806
Idle Speed and Ignition Timing Check	685	Description	806
Idle Speed/Ignition Timing/Idle Mixture Ratio Adjustment	687	CONSULT-II Reference Value in Data Monitor Mode	806
Accelerator Pedal Released Position Learning	698	On Board Diagnosis Logic	806
Throttle Valve Closed Position Learning	698	DTC Confirmation Procedure	807
Idle Air Volume Learning	698	Wiring Diagram	808
Fuel Pressure Check	700	Diagnostic Procedure	811
ON BOARD DIAGNOSTIC (OBD) SYSTEM	703	Component Inspection	813
Introduction	703	Removal and Installation	813
Two Trip Detection Logic	703	DTC P0037, P0038, P0057, P0058 HO2S2 HEATER	814
Emission-related Diagnostic Information	704	Description	814
IVIS (Infiniti Vehicle Immobilizer System — NATS)	717	CONSULT-II Reference Value in Data Monitor Mode	814
Malfunction Indicator Lamp (MIL)	717	On Board Diagnosis Logic	814
OBD System Operation Chart	721	DTC Confirmation Procedure	815
TROUBLE DIAGNOSIS	726	Wiring Diagram	816
Trouble Diagnosis Introduction	726	Diagnostic Procedure	819
DTC Inspection Priority Chart	729	Component Inspection	821
Fail-safe Chart	731	Removal and Installation	821
Basic Inspection	733	DTC P0101 MAF SENSOR	822
Symptom Matrix Chart	738	Component Description	822
Engine Control Component Parts Location	742	CONSULT-II Reference Value in Data Monitor Mode	822
Circuit Diagram	748	On Board Diagnosis Logic	822
ECM Harness Connector Terminal Layout	750	DTC Confirmation Procedure	823
ECM Terminals and Reference Value	750	Overall Function Check	824
CONSULT-II Function	759	Wiring Diagram	825
Generic Scan Tool (GST) Function	772	Diagnostic Procedure	826
CONSULT-II Reference Value in Data Monitor	775	Component Inspection	829
Major Sensor Reference Graph in Data Monitor Mode	778	Removal and Installation	829
TROUBLE DIAGNOSIS - SPECIFICATION VALUE	780	DTC P0102, P0103 MAF SENSOR	830
Description	780	Component Description	830
Testing Condition	780	CONSULT-II Reference Value in Data Monitor Mode	830
Inspection Procedure	780	On Board Diagnosis Logic	830
Diagnostic Procedure	781	DTC Confirmation Procedure	831
TROUBLE DIAGNOSIS FOR INTERMITTENT INCIDENT	784	Wiring Diagram	832
Description	784	Diagnostic Procedure	833
Diagnostic Procedure	784	Component Inspection	836
POWER SUPPLY AND GROUND CIRCUIT	785	Removal and Installation	836
Wiring Diagram	785	DTC P0112, P0113 IAT SENSOR	837
Diagnostic Procedure	786	Component Description	837
Ground Inspection	791	On Board Diagnosis Logic	837
DTC U1000, U1001 CAN COMMUNICATION LINE	792	DTC Confirmation Procedure	837
Description	792		

Wiring Diagram	839	Wiring Diagram	875	
Diagnostic Procedure	840	Diagnostic Procedure	878	A
Component Inspection	841	Component Inspection	882	
Removal and Installation	841	Removal and Installation	883	
DTC P0117, P0118 ECT SENSOR	842	DTC P0134, P0154 HO2S1	884	EC
Component Description	842	Component Description	884	
On Board Diagnosis Logic	842	CONSULT-II Reference Value in Data Monitor Mode		
DTC Confirmation Procedure	843		884	
Wiring Diagram	844	On Board Diagnosis Logic	884	C
Diagnostic Procedure	845	DTC Confirmation Procedure	885	
Component Inspection	846	Overall Function Check	886	
Removal and Installation	847	Wiring Diagram	887	D
DTC P0122, P0123 TP SENSOR	848	Diagnostic Procedure	890	
Component Description	848	Component Inspection	892	
CONSULT-II Reference Value in Data Monitor Mode		Removal and Installation	893	E
	848	DTC P0138, P0158 HO2S2	894	
On Board Diagnosis Logic	848	Component Description	894	
DTC Confirmation Procedure	849	CONSULT-II Reference Value in Data Monitor Mode		
Wiring Diagram	850		894	F
Diagnostic Procedure	851	On Board Diagnosis Logic	894	
Component Inspection	854	DTC Confirmation Procedure	895	
Removal and Installation	854	Wiring Diagram	896	G
DTC P0125 ECT SENSOR	855	Diagnostic Procedure	899	
Component Description	855	Component Inspection	901	
On Board Diagnosis Logic	855	Removal and Installation	902	H
DTC Confirmation Procedure	856	DTC P0139, P0159 HO2S2	903	
Diagnostic Procedure	856	Component Description	903	
Component Inspection	857	CONSULT-II Reference Value in Data Monitor Mode		
Removal and Installation	857		903	I
DTC P0127 IAT SENSOR	858	On Board Diagnosis Logic	903	
Component Description	858	DTC Confirmation Procedure	904	
On Board Diagnosis Logic	858	Overall Function Check	904	J
DTC Confirmation Procedure	858	Wiring Diagram	906	
Diagnostic Procedure	859	Diagnostic Procedure	909	
Component Inspection	860	Component Inspection	912	K
Removal and Installation	860	Removal and Installation	913	
DTC P0128 THERMOSTAT FUNCTION	861	DTC P0171, P0174 FUEL INJECTION SYSTEM		
On Board Diagnosis Logic	861	FUNCTION	914	L
DTC Confirmation Procedure	861	On Board Diagnosis Logic	914	
Diagnostic Procedure	861	DTC Confirmation Procedure	914	
Component Inspection	862	Wiring Diagram	916	
Removal and Installation	862	Diagnostic Procedure	918	M
DTC P0132, P0152 HO2S1	863	DTC P0172, P0175 FUEL INJECTION SYSTEM		
Component Description	863	FUNCTION	923	
CONSULT-II Reference Value in Data Monitor Mode		On Board Diagnosis Logic	923	
	863	DTC Confirmation Procedure	923	
On Board Diagnosis Logic	863	Wiring Diagram	925	
DTC Confirmation Procedure	864	Diagnostic Procedure	927	
Wiring Diagram	865	DTC P0181 FTT SENSOR	931	
Diagnostic Procedure	868	Component Description	931	
Component Inspection	870	On Board Diagnosis Logic	931	
Removal and Installation	871	DTC Confirmation Procedure	931	
DTC P0133, P0153 HO2S1	872	Wiring Diagram	933	
Component Description	872	Diagnostic Procedure	934	
CONSULT-II Reference Value in Data Monitor Mode		Component Inspection	936	
	872	Removal and Installation	936	
On Board Diagnosis Logic	872	DTC P0182, P0183 FTT SENSOR	937	
DTC Confirmation Procedure	873	Component Description	937	
Overall Function Check	874	On Board Diagnosis Logic	937	

DTC Confirmation Procedure	937	DTC P0442 EVAP CONTROL SYSTEM	981
Wiring Diagram	938	On Board Diagnosis Logic	981
Diagnostic Procedure	939	DTC Confirmation Procedure	982
Component Inspection	941	Diagnostic Procedure	983
Removal and Installation	941	DTC P0444, P0445 EVAP CANISTER PURGE VOL-	
DTC P0222, P0223 TP SENSOR	942	UME CONTROL SOLENOID VALVE	990
Component Description	942	Description	990
CONSULT-II Reference Value in Data Monitor Mode	942	CONSULT-II Reference Value in Data Monitor Mode	990
On Board Diagnosis Logic	942	On Board Diagnosis Logic	991
DTC Confirmation Procedure	943	DTC Confirmation Procedure	991
Wiring Diagram	944	Wiring Diagram	992
Diagnostic Procedure	945	Diagnostic Procedure	994
Component Inspection	948	Component Inspection	995
Removal and Installation	948	Removal and Installation	996
DTC P0300 - P0308 MULTIPLE CYLINDER MIS-		DTC P0447 EVAP CANISTER VENT CONTROL	
FIRE, NO. 1 - 8 CYLINDER MISFIRE	949	VALVE	997
On Board Diagnosis Logic	949	Component Description	997
DTC Confirmation Procedure	949	CONSULT-II Reference Value in Data Monitor Mode	997
Diagnostic Procedure	950	On Board Diagnosis Logic	997
DTC P0327, P0328, P0332, P0333 KS	955	DTC Confirmation Procedure	998
Component Description	955	Wiring Diagram	999
On Board Diagnosis Logic	955	Diagnostic Procedure	1000
DTC Confirmation Procedure	955	Component Inspection	1002
Wiring Diagram	956	DTC P0451 EVAP CONTROL SYSTEM PRESSURE	
Diagnostic Procedure	957	SENSOR	1004
Component Inspection	959	Component Description	1004
Removal and Installation	959	CONSULT-II Reference Value in Data Monitor Mode	1004
DTC P0335 CKP SENSOR (POS)	960	On Board Diagnosis Logic	1004
Component Description	960	DTC Confirmation Procedure	1005
CONSULT-II Reference Value in Data Monitor Mode	960	Diagnostic Procedure	1005
On Board Diagnosis Logic	960	Component Inspection	1006
DTC Confirmation Procedure	960	DTC P0452 EVAP CONTROL SYSTEM PRESSURE	
Wiring Diagram	961	SENSOR	1007
Diagnostic Procedure	962	Component Description	1007
Component Inspection	964	CONSULT-II Reference Value in Data Monitor Mode	1007
Removal and Installation	965	On Board Diagnosis Logic	1007
DTC P0340 CAMSHAFT POSITION (CMP) SEN-		DTC Confirmation Procedure	1008
SOR (PHASE)	966	Wiring Diagram	1009
Component Description	966	Diagnostic Procedure	1010
On Board Diagnosis Logic	966	Component Inspection	1013
DTC Confirmation Procedure	966	DTC P0453 EVAP CONTROL SYSTEM PRESSURE	
Wiring Diagram	967	SENSOR	1014
Diagnostic Procedure	968	Component Description	1014
Component Inspection	970	CONSULT-II Reference Value in Data Monitor Mode	1014
Removal and Installation	970	On Board Diagnosis Logic	1014
DTC P0420, P0430 THREE WAY CATALYST FUNC-		DTC Confirmation Procedure	1015
TION	971	Wiring Diagram	1016
On Board Diagnosis Logic	971	Diagnostic Procedure	1017
DTC Confirmation Procedure	971	Component Inspection	1021
Overall Function Check	972	DTC P0455 EVAP CONTROL SYSTEM	1022
Diagnostic Procedure	973	On Board Diagnosis Logic	1022
DTC P0441 EVAP CONTROL SYSTEM	976	DTC Confirmation Procedure	1023
System Description	976	Diagnostic Procedure	1024
On Board Diagnosis Logic	976		
DTC Confirmation Procedure	976		
Overall Function Check	977		
Diagnostic Procedure	978		

DTC P0456 EVAP CONTROL SYSTEM	1030	Wiring Diagram	1061	
On Board Diagnosis Logic	1030	Diagnostic Procedure	1062	A
DTC Confirmation Procedure	1031	DTC P1102 MAF SENSOR	1064	
Overall Function Check	1032	Component Description	1064	
Diagnostic Procedure	1033	CONSULT-II Reference Value in Data Monitor Mode		EC
DTC P0460 FUEL LEVEL SENSOR	1040		1064	
Component Description	1040	On Board Diagnosis Logic	1064	
On Board Diagnosis Logic	1040	DTC Confirmation Procedure	1065	C
DTC Confirmation Procedure	1040	Wiring Diagram	1066	
Diagnostic Procedure	1041	Diagnostic Procedure	1067	
Removal and Installation	1041	Component Inspection	1069	D
DTC P0461 FUEL LEVEL SENSOR	1042	Removal and Installation	1069	
Component Description	1042	DTC P1111, P1136 IVT CONTROL SOLENOID		
On Board Diagnosis Logic	1042	VALVE	1070	
Overall Function Check	1042	Component Description	1070	E
Diagnostic Procedure	1043	CONSULT-II Reference Value in Data Monitor Mode		
Removal and Installation	1043		1070	
DTC P0462, P0463 FUEL LEVEL SENSOR CIR-		On Board Diagnosis Logic	1070	F
CUIT	1044	DTC Confirmation Procedure	1070	
Component Description	1044	Wiring Diagram	1071	
On Board Diagnosis Logic	1044	Diagnostic Procedure	1074	G
DTC Confirmation Procedure	1044	Component Inspection	1076	
Diagnostic Procedure	1045	Removal and Installation	1076	
Removal and Installation	1045	DTC P1121 ELECTRIC THROTTLE CONTROL		
DTC P0500 VSS	1046	ACTUATOR	1077	H
Description	1046	Component Description	1077	
On Board Diagnosis Logic	1046	On Board Diagnosis Logic	1077	
DTC Confirmation Procedure	1046	DTC Confirmation Procedure	1077	I
Overall Function Check	1047	Diagnostic Procedure	1078	
Diagnostic Procedure	1047	DTC P1122 ELECTRIC THROTTLE CONTROL		
DTC P0506 ISC SYSTEM	1048	FUNCTION	1079	J
Description	1048	Description	1079	
On Board Diagnosis Logic	1048	On Board Diagnosis Logic	1079	
DTC Confirmation Procedure	1048	DTC Confirmation Procedure	1079	K
Diagnostic Procedure	1049	Wiring Diagram	1080	
DTC P0507 ISC SYSTEM	1050	Diagnostic Procedure	1081	
Description	1050	Component Inspection	1084	L
On Board Diagnosis Logic	1050	Removal and Installation	1084	
DTC Confirmation Procedure	1050	DTC P1124, P1126 THROTTLE CONTROL MOTOR		
Diagnostic Procedure	1051	RELAY	1085	M
DTC P0550 PSP SENSOR	1052	Component Description	1085	
Component Description	1052	CONSULT-II Reference Value in Data Monitor Mode		
CONSULT-II Reference Value in Data Monitor Mode			1085	
On Board Diagnosis Logic	1052	On Board Diagnosis Logic	1085	
DTC Confirmation Procedure	1052	DTC Confirmation Procedure	1085	
Wiring Diagram	1053	Wiring Diagram	1087	
Diagnostic Procedure	1054	Diagnostic Procedure	1088	
Component Inspection	1056	DTC P1128 THROTTLE CONTROL MOTOR	1090	
Removal and Installation	1056	Component Description	1090	
DTC P0605 ECM	1057	On Board Diagnosis Logic	1090	
Component Description	1057	DTC Confirmation Procedure	1090	
On Board Diagnosis Logic	1057	Wiring Diagram	1091	
DTC Confirmation Procedure	1057	Diagnostic Procedure	1092	
Diagnostic Procedure	1058	Component Inspection	1093	
DTC P1065 ECM POWER SUPPLY	1060	Removal and Installation	1094	
Component Description	1060	DTC P1140, P1145 IVT CONTROL POSITION SEN-		
On Board Diagnosis Logic	1060	SOR	1095	
DTC Confirmation Procedure	1060	Component Description	1095	
		CONSULT-II Reference Value in Data Monitor Mode		

On Board Diagnosis Logic	1095	DTC P1212 TCS COMMUNICATION LINE	1141
DTC Confirmation Procedure	1095	Description	1141
Wiring Diagram	1096	On Board Diagnosis Logic	1141
Diagnostic Procedure	1099	DTC Confirmation Procedure	1141
Component Inspection	1102	Diagnostic Procedure	1141
Removal and Installation	1102	DTC P1217 ENGINE OVER TEMPERATURE	1142
DTC P1143, P1163 HO2S1	1103	Description	1142
Component Description	1103	CONSULT-II Reference Value in Data Monitor Mode	1143
CONSULT-II Reference Value in Data Monitor Mode	1103	On Board Diagnosis Logic	1143
On Board Diagnosis Logic	1103	Overall Function Check	1143
DTC Confirmation Procedure	1104	Wiring Diagram	1145
Overall Function Check	1105	Diagnostic Procedure	1147
Diagnostic Procedure	1105	Main 12 Causes of Overheating	1150
Component Inspection	1107	Component Inspection	1151
Removal and Installation	1108	DTC P1225 TP SENSOR	1152
DTC P1144, P1164 HO2S1	1109	Component Description	1152
Component Description	1109	On Board Diagnosis Logic	1152
CONSULT-II Reference Value in Data Monitor Mode	1109	DTC Confirmation Procedure	1152
On Board Diagnosis Logic	1109	Diagnostic Procedure	1153
DTC Confirmation Procedure	1110	Removal and Installation	1153
Overall Function Check	1111	DTC P1226 TP SENSOR	1154
Diagnostic Procedure	1111	Component Description	1154
Component Inspection	1113	On Board Diagnosis Logic	1154
Removal and Installation	1115	DTC Confirmation Procedure	1154
DTC P1146, P1166 HO2S2	1116	Diagnostic Procedure	1155
Component Description	1116	Removal and Installation	1155
CONSULT-II Reference Value in Data Monitor Mode	1116	DTC P1229 SENSOR POWER SUPPLY	1156
On Board Diagnosis Logic	1116	On Board Diagnosis Logic	1156
DTC Confirmation Procedure	1117	DTC Confirmation Procedure	1156
Overall Function Check	1117	Wiring Diagram	1157
Wiring Diagram	1119	Diagnostic Procedure	1158
Diagnostic Procedure	1122	DTC P1444 EVAP CANISTER PURGE VOLUME CONTROL SOLENOID VALVE	1160
Component Inspection	1125	Description	1160
Removal and Installation	1126	CONSULT-II Reference Value in Data Monitor Mode	1160
DTC P1147, P1167 HO2S2	1127	On Board Diagnosis Logic	1161
Component Description	1127	DTC Confirmation Procedure	1161
CONSULT-II Reference Value in Data Monitor Mode	1127	Wiring Diagram	1162
On Board Diagnosis Logic	1127	Diagnostic Procedure	1164
DTC Confirmation Procedure	1128	Component Inspection	1167
Overall Function Check	1128	Removal and Installation	1167
Wiring Diagram	1130	DTC P1446 EVAP CANISTER VENT CONTROL VALVE	1168
Diagnostic Procedure	1133	Component Description	1168
Component Inspection	1136	CONSULT-II Reference Value in Data Monitor Mode	1168
Removal and Installation	1137	On Board Diagnosis Logic	1168
DTC P1148, P1168 CLOSED LOOP CONTROL	1138	DTC Confirmation Procedure	1169
On Board Diagnosis Logic	1138	Wiring Diagram	1170
DTC Confirmation Procedure	1138	Diagnostic Procedure	1171
Overall Function Check	1139	Component Inspection	1172
Diagnostic Procedure	1139	DTC P1564 ICC STEERING SWITCH	1174
DTC P1211 TCS CONTROL UNIT	1140	Component Description	1174
Description	1140	CONSULT-II Reference Value in Data Monitor Mode	1174
On Board Diagnosis Logic	1140	On Board Diagnosis Logic	1174
DTC Confirmation Procedure	1140	DTC Confirmation Procedure	1174
Diagnostic Procedure	1140		

Wiring Diagram	1176	DTC Confirmation Procedure	1216	
Diagnostic Procedure	1177	Diagnostic Procedure	1217	A
Component Inspection	1180	DTC P1780 SHIFT CHANGE SIGNAL	1218	
DTC P1564 ASCD STEERING SWITCH	1181	Description	1218	
Component Description	1181	On Board Diagnosis Logic	1218	EC
CONSULT-II Reference Value in Data Monitor Mode	1181	DTC Confirmation Procedure	1218	
On Board Diagnosis Logic	1181	Diagnostic Procedure	1218	
DTC Confirmation Procedure	1182	DTC P1805 BRAKE SWITCH	1220	C
Wiring Diagram	1183	Description	1220	
Diagnostic Procedure	1184	CONSULT-II Reference Value in Data Monitor Mode	1220	
Component Inspection	1187	On Board Diagnosis Logic	1220	D
DTC P1568 ICC FUNCTION	1188	DTC Confirmation Procedure	1220	
On Board Diagnosis Logic	1188	Wiring Diagram	1221	
DTC Confirmation Procedure	1188	Diagnostic Procedure	1222	E
Diagnostic Procedure	1188	Component Inspection	1224	
DTC P1572 ICC BRAKE SWITCH	1189	DTC P2122, P2123 APP SENSOR	1225	
Component Description	1189	Component Description	1225	F
CONSULT-II Reference Value in Data Monitor Mode	1189	CONSULT-II Reference Value in Data Monitor Mode	1225	
On Board Diagnosis Logic	1189	On Board Diagnosis Logic	1225	
DTC Confirmation Procedure	1190	DTC Confirmation Procedure	1226	G
Wiring Diagram	1191	Wiring Diagram	1227	
Diagnostic Procedure	1192	Diagnostic Procedure	1228	
Component Inspection	1197	Component Inspection	1230	H
DTC P1572 ASCD BRAKE SWITCH	1199	Removal and Installation	1231	
Component Description	1199	DTC P2127, P2128 APP SENSOR	1232	
CONSULT-II Reference Value in Data Monitor Mode	1199	Component Description	1232	I
On Board Diagnosis Logic	1199	CONSULT-II Reference Value in Data Monitor Mode	1232	
DTC Confirmation Procedure	1200	On Board Diagnosis Logic	1232	
Wiring Diagram	1201	DTC Confirmation Procedure	1233	J
Diagnostic Procedure	1202	Wiring Diagram	1234	
Component Inspection	1206	Diagnostic Procedure	1235	
DTC P1574 ICC VEHICLE SPEED SENSOR	1207	Component Inspection	1238	K
Component Description	1207	Removal and Installation	1238	
On Board Diagnosis Logic	1207	DTC P2135 TP SENSOR	1239	
DTC Confirmation Procedure	1207	Component Description	1239	L
Diagnostic Procedure	1208	CONSULT-II Reference Value in Data Monitor Mode	1239	
DTC P1574 ASCD VEHICLE SPEED SENSOR	1209	On Board Diagnosis Logic	1239	
Component Description	1209	DTC Confirmation Procedure	1240	M
On Board Diagnosis Logic	1209	Wiring Diagram	1241	
DTC Confirmation Procedure	1209	Diagnostic Procedure	1242	
Diagnostic Procedure	1210	Component Inspection	1245	
DTC P1706 PNP SWITCH	1211	Removal and Installation	1245	
Component Description	1211	DTC P2138 APP SENSOR	1246	
CONSULT-II Reference Value in Data Monitor Mode	1211	Component Description	1246	
On Board Diagnosis Logic	1211	CONSULT-II Reference Value in Data Monitor Mode	1246	
DTC Confirmation Procedure	1211	On Board Diagnosis Logic	1246	
Overall Function Check	1212	DTC Confirmation Procedure	1247	
Wiring Diagram	1213	Wiring Diagram	1248	
Diagnostic Procedure	1214	Diagnostic Procedure	1249	
DTC P1720 VEHICLE SPEED SENSOR (A/T OUT-PUT)	1216	Component Inspection	1253	
Description	1216	Removal and Installation	1253	
CONSULT-II Reference Value in Data Monitor Mode	1216	VARIABLE INDUCTION AIR CONTROL SYSTEM (VIAS)	1254	
On Board Diagnosis Logic	1216	Description	1254	

CONSULT-II Reference Value in Data Monitor Mode	1255	Wiring Diagram	1303
Wiring Diagram	1256	Diagnostic Procedure	1304
Diagnostic Procedure	1257	Component Inspection	1308
Component Inspection	1260	ASCD INDICATOR	1309
Removal and Installation	1261	Component Description	1309
IGNITION SIGNAL	1262	CONSULT-II Reference Value in Data Monitor Mode	1309
Component Description	1262	Wiring Diagram	1310
Wiring Diagram	1263	Diagnostic Procedure	1311
Diagnostic Procedure	1268	SNOW MODE SWITCH	1312
Component Inspection	1272	Description	1312
Removal and Installation	1273	CONSULT-II Reference Value in the Data Monitor	
INJECTOR CIRCUIT	1274	Mode	1312
Component Description	1274	Wiring Diagram	1313
CONSULT-II Reference Value in Data Monitor Mode	1274	Diagnostic Procedure	1314
Wiring Diagram	1275	Component Inspection	1317
Diagnostic Procedure	1276	MIL AND DATA LINK CONNECTOR	1318
Component Inspection	1279	Wiring Diagram	1318
Removal and Installation	1279	EVAPORATIVE EMISSION SYSTEM	1320
FUEL PUMP CIRCUIT	1280	Description	1320
Description	1280	Component Inspection	1323
CONSULT-II Reference Value in Data Monitor Mode	1280	Removal and Installation	1324
Wiring Diagram	1281	How to Detect Fuel Vapor Leakage	1324
Diagnostic Procedure	1282	ON BOARD REFUELING VAPOR RECOVERY	
Component Inspection	1285	(ORVR)	1327
Removal and Installation	1286	System Description	1327
REFRIGERANT PRESSURE SENSOR	1287	Diagnostic Procedure	1328
Component Description	1287	Component Inspection	1330
Wiring Diagram	1288	POSITIVE CRANKCASE VENTILATION	1332
Diagnostic Procedure	1289	Description	1332
Removal and Installation	1291	Component Inspection	1332
ELECTRICAL LOAD SIGNAL	1292	AUTOMATIC SPEED CONTROL DEVICE (ASCD)	1334
Description	1292	System Description	1334
CONSULT-II Reference Value in Data Monitor Mode	1292	Component Description	1335
Diagnostic Procedure	1292	SERVICE DATA AND SPECIFICATIONS (SDS)	1336
ICC BRAKE SWITCH	1293	Fuel Pressure	1336
Component Description	1293	Idle Speed and Ignition Timing	1336
CONSULT-II Reference Value in Data Monitor Mode	1293	Calculated Load Value	1336
Wiring Diagram	1294	Mass Air Flow Sensor	1336
Diagnostic Procedure	1295	Intake Air Temperature Sensor	1336
Component Inspection	1301	Engine Coolant Temperature Sensor	1336
ASCD BRAKE SWITCH	1302	Heated Oxygen Sensor 1 Heater	1336
Component Description	1302	Heated Oxygen Sensor 2 Heater	1336
CONSULT-II Reference Value in Data Monitor Mode	1302	Crankshaft Position Sensor (POS)	1336
	1302	Camshaft Position Sensor (PHASE)	1336
		Throttle Control Motor	1336
		Injector	1337
		Fuel Pump	1337

INDEX FOR DTC

[VQ35DE]

PFP:00024

ABS006JV

INDEX FOR DTC

Alphabetical Index

NOTE:

If DTC U1000 or U1001 is displayed with other DTC, first perform the trouble diagnosis for DTC U1000, U1001. Refer to [EC-142, "DTC U1000, U1001 CAN COMMUNICATION LINE"](#) .

×:Applicable —: Not applicable

Items (CONSULT-II screen terms)	DTC*1		Trip	MIL lighting up	Reference page
	CONSULT-II GST*2	ECM*3			
A/T INTERLOCK	P1730	1730	1	×	AT-147
A/T TCC S/V FNCTN	P0744	0744	2	×	AT-125
ACC COMMAND VALUE*8	P1568	1568	1	—	EC-521
APP SEN 1/CIRC	P2122	2122	1	×	EC-555
APP SEN 1/CIRC	P2123	2123	1	×	EC-555
APP SEN 2/CIRC	P2127	2127	1	×	EC-562
APP SEN 2/CIRC	P2128	2128	1	×	EC-562
APP SENSOR	P2138	2138	1	×	EC-576
ASCD BRAKE SW*7	P1572	1572	1	—	EC-522, EC-532
ASCD SW*7	P1564	1564	1	—	EC-508, EC-515
ASCD VHL SPD SEN*7	P1574	1574	1	—	EC-541, EC-543
ATF TEMP SEN/CIRC	P0710	0710	2	×	AT-139
BRAKE SW/CIRCUIT	P1805	1805	2	—	EC-550
CAN COMM CIRCUIT	U1000	1000*5	1	×	EC-142
CAN COMM CIRCUIT	U1001	1001*5	2	—	EC-142
CKP SEN/CIRCUIT	P0335	0335	2	×	EC-302
CLOSED LOOP-B1	P1148	1148	1	×	EC-468
CLOSED LOOP-B2	P1168	1168	1	×	EC-468
CMP SEN/CIRC-B1	P0340	0340	2	×	EC-308
CMP SEN/CIRC-B2	P0345	0345	2	×	EC-308
CTP LEARNING	P1225	1225	2	—	EC-485
CTP LEARNING	P1226	1226	2	—	EC-487
CYL 1 MISFIRE	P0301	0301	2	×	EC-291
CYL 2 MISFIRE	P0302	0302	2	×	EC-291
CYL 3 MISFIRE	P0303	0303	2	×	EC-291
CYL 4 MISFIRE	P0304	0304	2	×	EC-291
CYL 5 MISFIRE	P0305	0305	2	×	EC-291
CYL 6 MISFIRE	P0306	0306	2	×	EC-291
D/C SOLENOID/CIRC	P1762	1762	1	×	AT-160
D/C SOLENOID FNCTN	P1764	1764	1	×	AT-162
ECM	P0605	0605	1 or 2	× or —	EC-401
ECM BACK UP/CIRCUIT	P1065	1065	2	×	EC-404
ECT SEN/CIRCUIT	P0117	0117	1	×	EC-185
ECT SEN/CIRCUIT	P0118	0118	1	×	EC-185
ECT SENSOR	P0125	0125	1	×	EC-197
ENG OVER TEMP	P1217	1217	1	×	EC-472

INDEX FOR DTC

[VQ35DE]

Items (CONSULT-II screen terms)	DTC*1		Trip	MIL lighting up	Reference page
	CONSULT-II GST*2	ECM*3			
ENGINE SPEED SIG	P0725	0725	2	×	AT-121
ETC ACTR	P1121	1121	1	×	EC-415
ETC FUNCTION/CIRC	P1122	1122	1	×	EC-417
ETC MOT	P1128	1128	1	×	EC-428
ETC MOT PWR	P1124	1124	1	×	EC-423
ETC MOT PWR	P1126	1126	1	×	EC-423
EVAP GROSS LEAK	P0455	0455	2	×	EC-366
EVAP PURG FLOW/MON	P0441	0441	2	×	EC-321
EVAP SMALL LEAK	P0442	0442	2	×	EC-326
EVAP SYS PRES SEN	P0451	0451	2	×	EC-349
EVAP SYS PRES SEN	P0452	0452	2	×	EC-352
EVAP SYS PRES SEN	P0453	0453	2	×	EC-358
EVAP VERY SML LEAK	P0456	0456	2	×	EC-374
FR/B SOLENOID/CIRC	P1757	1757	1	×	AT-156
FR/B SOLENOID FNCT	P1759	1759	1	×	AT-158
FTT SEN/CIRCUIT	P0182	0182	2	×	EC-279
FTT SEN/CIRCUIT	P0183	0183	2	×	EC-279
FTT SENSOR	P0181	0181	2	×	EC-273
FUEL LEV SEN SLOSH	P0460	0460	2	×	EC-384
FUEL LEVEL SENSOR	P0461	0461	2	×	EC-386
FUEL LEVL SEN/CIRC	P0462	0462	2	×	EC-388
FUEL LEVL SEW/CIRC	P0463	0463	2	×	EC-388
FUEL SYS-LEAN-B1	P0171	0171	2	×	EC-256
FUEL SYS-LEAN-B2	P0174	0174	2	×	EC-256
FUEL SYS-RICH-B1	P0172	0172	2	×	EC-265
FUEL SYS-RICH-B2	P0175	0175	2	×	EC-265
HLR/C SOL FNCTN	P1769	1769	1	×	AT-166
HLR/C SOL/CIRC	P1767	1767	1	×	AT-164
HO2S1 (B1)	P0132	0132	2	×	EC-205
HO2S1 (B1)	P0133	0133	2	×	EC-214
HO2S1 (B1)	P0134	0134	2	×	EC-226
HO2S1 (B1)	P1143	1143	2	×	EC-433
HO2S1 (B1)	P1144	1144	2	×	EC-439
HO2S1 (B2)	P0152	0152	2	×	EC-205
HO2S1 (B2)	P0153	0153	2	×	EC-214
HO2S1 (B2)	P0154	0154	2	×	EC-226
HO2S1 (B2)	P1163	1163	2	×	EC-433
HO2S1 (B2)	P1164	1164	2	×	EC-439
HO2S1 HTR (B1)	P0031	0031	2	×	EC-149
HO2S1 HTR (B1)	P0032	0032	2	×	EC-149
HO2S1 HTR (B2)	P0051	0051	2	×	EC-149
HO2S1 HTR (B2)	P0052	0052	2	×	EC-149

INDEX FOR DTC

[VQ35DE]

Items (CONSULT-II screen terms)	DTC*1		Trip	MIL lighting up	Reference page
	CONSULT-II GST*2	ECM*3			
HO2S2 (B1)	P0138	0138	2	×	EC-236
HO2S2 (B1)	P0139	0139	2	×	EC-245
HO2S2 (B1)	P1146	1146	2	×	EC-446
HO2S2 (B1)	P1147	1147	2	×	EC-457
HO2S2 (B2)	P0158	0158	2	×	EC-236
HO2S2 (B2)	P0159	0159	2	×	EC-245
HO2S2 (B2)	P1166	1166	2	×	EC-446
HO2S2 (B2)	P1167	1167	2	×	EC-457
HO2S2 HTR (B1)	P0037	0037	2	×	EC-157
HO2S2 HTR (B1)	P0038	0038	2	×	EC-157
HO2S2 HTR (B2)	P0057	0057	2	×	EC-157
HO2S2 HTR (B2)	P0058	0058	2	×	EC-157
I/C SOLENOID/CIRC	P1752	1752	1	×	AT-152
I/C SOLENOID FNCTN	P1754	1754	1	×	AT-154
IAT SEN/CIRCUIT	P0112	0112	2	×	EC-180
IAT SEN/CIRCUIT	P0113	0113	2	×	EC-180
IAT SENSOR	P0127	0127	2	×	EC-200
INT/V TIM CONT-B1	P0011	0011	2	×	EC-145
INT/V TIM CONT-B2	P0021	0021	2	×	EC-145
INT/V TIM V/CIR-B1	P1111	1111	2	×	EC-408
INT/V TIM V/CIR-B2	P1136	1136	2	×	EC-408
ISC SYSTEM	P0506	0506	2	×	EC-392
ISC SYSTEM	P0507	0507	2	×	EC-394
KNOCK SEN/CIRC-B1	P0327	0327	2	—	EC-297
KNOCK SEN/CIRC-B1	P0328	0328	2	—	EC-297
L/PRESS SOL/CIRC	P0745	0745	2	×	AT-127
LC/B SOLENOID FNCT	P1774	1774	1	×	AT-170
LC/B SOLENOID/CIRC	P1772	1772	1	×	AT-168
MAF SEN/CIRCUIT	P0101	0101	1	×	EC-165
MAF SEN/CIRCUIT	P0102	0102	1	×	EC-173
MAF SEN/CIRCUIT	P0103	0103	1	×	EC-173
MULTI CYL MISFIRE	P0300	0300	2	×	EC-291
NATS MALFUNCTION	P1610 - P1615	1610 - 1615	2	—	EC-68
NO DTC IS DETECTED. FURTHER TESTING MAY BE REQUIRED.	No DTC	Flashing*4	—	Flashing*4	EC-69
NO DTC IS DETECTED. FURTHER TESTING MAY BE REQUIRED.	P0000	0000	—	—	—
P-N POS SW/CIRCUIT	P1706	1706	2	×	EC-545
PNP SW/CIRC	P0705	0705	2	×	AT-112
PURG VOLUME CONT/V	P0444	0444	2	×	EC-335
PURG VOLUME CONT/V	P0445	0445	2	×	EC-335
PURG VOLUME CONT/V	P1444	1444	2	×	EC-494

INDEX FOR DTC

[VQ35DE]

Items (CONSULT-II screen terms)	DTC*1		Trip	MIL lighting up	Reference page
	CONSULT-II GST*2	ECM*3			
PW ST P SEN/CIRC	P0550	0550	2	—	EC-396
SENSOR POWER/CIRC	P1229	1229	1	×	EC-489
TCC SOLENOID/CIRC	P0740	0740	2	×	AT-123
TCS C/U FUNCTN	P1211	1211	2	—	EC-470
TCS/CIRC	P1212	1212	2	—	EC-471
THERMSTAT FNCTN	P0128	0128	2	×	EC-203
TP SEN 1/CIRC	P0222	0222	1	×	EC-284
TP SEN 1/CIRC	P0223	0223	1	×	EC-284
TP SEN 2/CIRC	P0122	0122	1	×	EC-190
TP SEN 2/CIRC	P0123	0123	1	×	EC-190
TP SEN/CIRC A/T	P1705	1705	1	×	AT-136
TP SENSOR	P2135	2135	1	×	EC-569
TURBINE REV S/CIRC	P1716	1716	2	×	AT-143
TW CATALYST SYS-B1	P0420	0420	2	×	EC-316
TW CATALYST SYS-B2	P0430	0430	2	×	EC-316
VEH SPD SEN/CIR AT*6	P0720	0720	2	×	AT-116
VEH SPEED SEN/CIRC*6	P0500	0500	2	×	EC-390
VENT CONTROL VALVE	P0447	0447	2	×	EC-342
VENT CONTROL VALVE	P1446	1446	2	×	EC-502

*1: 1st trip DTC No. is the same as DTC No.

*2: This number is prescribed by SAE J2012.

*3: In Diagnostic Test Mode II (Self-diagnostic results), this number is controlled by NISSAN.

*4: When engine is running.

*5: The troubleshooting for this DTC needs CONSULT-II.

*6: When the fail-safe operations for both self-diagnoses occur, the MIL illuminates.

*7: For models with ICC or ASCD system.

*8: For models with ICC system.

INDEX FOR DTC

[VQ35DE]

ABS006JW

DTC No. Index

NOTE:

If DTC U1000 or U1001 is displayed with other DTC, first perform the trouble diagnosis for DTC U1000, U1001. Refer to [EC-142, "DTC U1000, U1001 CAN COMMUNICATION LINE"](#).

×:Applicable —: Not applicable

DTC*1		Items (CONSULT-II screen terms)	Trip	MIL lighting up	Reference page
CONSULT-II GST*2	ECM*3				
No DTC	Flashing*4	NO DTC IS DETECTED. FURTHER TESTING MAY BE REQUIRED.	—	Flashing*4	EC-69
U1000	1000*5	CAN COMM CIRCUIT	1	×	EC-142
U1001	1001*5	CAN COMM CIRCUIT	2	—	EC-142
P0000	0000	NO DTC IS DETECTED. FURTHER TESTING MAY BE REQUIRED.	—	—	—
P0011	0011	INT/V TIM CONT-B1	2	×	EC-145
P0021	0021	INT/V TIM CONT-B2	2	×	EC-145
P0031	0031	HO2S1 HTR (B1)	2	×	EC-149
P0032	0032	HO2S1 HTR (B1)	2	×	EC-149
P0037	0037	HO2S2 HTR (B1)	2	×	EC-157
P0038	0038	HO2S2 HTR (B1)	2	×	EC-157
P0051	0051	HO2S1 HTR (B2)	2	×	EC-149
P0052	0052	HO2S1 HTR (B2)	2	×	EC-149
P0057	0057	HO2S2 HTR (B2)	2	×	EC-157
P0058	0058	HO2S2 HTR (B2)	2	×	EC-157
P0101	0101	MAF SEN/CIRCUIT	1	×	EC-165
P0102	0102	MAF SEN/CIRCUIT	1	×	EC-173
P0103	0103	MAF SEN/CIRCUIT	1	×	EC-173
P0112	0112	IAT SEN/CIRCUIT	2	×	EC-180
P0113	0113	IAT SEN/CIRCUIT	2	×	EC-180
P0117	0117	ECT SEN/CIRCUIT	1	×	EC-185
P0118	0118	ECT SEN/CIRCUIT	1	×	EC-185
P0122	0122	TP SEN 2/CIRC	1	×	EC-190
P0123	0123	TP SEN 2/CIRC	1	×	EC-190
P0125	0125	ECT SENSOR	1	×	EC-197
P0127	0127	IAT SENSOR	2	×	EC-200
P0128	0128	THERMSTAT FNCTN	2	×	EC-203
P0132	0132	HO2S1 (B1)	2	×	EC-205
P0133	0133	HO2S1 (B1)	2	×	EC-214
P0134	0134	HO2S1 (B1)	2	×	EC-226
P0138	0138	HO2S2 (B1)	2	×	EC-236
P0139	0139	HO2S2 (B1)	2	×	EC-245
P0152	0152	HO2S1 (B2)	2	×	EC-205
P0153	0153	HO2S1 (B2)	2	×	EC-214
P0154	0154	HO2S1 (B2)	2	×	EC-226
P0158	0158	HO2S2 (B2)	2	×	EC-236

INDEX FOR DTC

[VQ35DE]

DTC*1		Items (CONSULT-II screen terms)	Trip	MIL lighting up	Reference page
CONSULT-II GST*2	ECM*3				
P0159	0159	HO2S2 (B2)	2	×	EC-245
P0171	0171	FUEL SYS-LEAN-B1	2	×	EC-256
P0172	0172	FUEL SYS-RICH-B1	2	×	EC-265
P0174	0174	FUEL SYS-LEAN-B2	2	×	EC-256
P0175	0175	FUEL SYS-RICH-B2	2	×	EC-265
P0181	0181	FTT SENSOR	2	×	EC-273
P0182	0182	FTT SEN/CIRCUIT	2	×	EC-279
P0183	0183	FTT SEN/CIRCUIT	2	×	EC-279
P0222	0222	TP SEN 1/CIRC	1	×	EC-284
P0223	0223	TP SEN 1/CIRC	1	×	EC-284
P0300	0300	MULTI CYL MISFIRE	2	×	EC-291
P0301	0301	CYL 1 MISFIRE	2	×	EC-291
P0302	0302	CYL 2 MISFIRE	2	×	EC-291
P0303	0303	CYL 3 MISFIRE	2	×	EC-291
P0304	0304	CYL 4 MISFIRE	2	×	EC-291
P0305	0305	CYL 5 MISFIRE	2	×	EC-291
P0306	0306	CYL 6 MISFIRE	2	×	EC-291
P0327	0327	KNOCK SEN/CIRC-B1	2	—	EC-297
P0328	0328	KNOCK SEN/CIRC-B1	2	—	EC-297
P0335	0335	CKP SEN/CIRCUIT	2	×	EC-302
P0340	0340	CMP SEN/CIRC-B1	2	×	EC-308
P0345	0345	CMP SEN/CIRC-B2	2	×	EC-308
P0420	0420	TW CATALYST SYS-B1	2	×	EC-316
P0430	0430	TW CATALYST SYS-B2	2	×	EC-316
P0441	0441	EVAP PURG FLOW/MON	2	×	EC-321
P0442	0442	EVAP SMALL LEAK	2	×	EC-326
P0444	0444	PURG VOLUME CONT/V	2	×	EC-335
P0445	0445	PURG VOLUME CONT/V	2	×	EC-335
P0447	0447	VENT CONTROL VALVE	2	×	EC-342
P0451	0451	EVAP SYS PRES SEN	2	×	EC-349
P0452	0452	EVAP SYS PRES SEN	2	×	EC-352
P0453	0453	EVAP SYS PRES SEN	2	×	EC-358
P0455	0455	EVAP GROSS LEAK	2	×	EC-366
P0456	0456	EVAP VERY SML LEAK	2	×	EC-374
P0460	0460	FUEL LEV SEN SLOSH	2	×	EC-384
P0461	0461	FUEL LEVEL SENSOR	2	×	EC-386
P0462	0462	FUEL LEVL SEN/CIRC	2	×	EC-388
P0463	0463	FUEL LEVL SEN/CIRC	2	×	EC-388
P0500	0500	VEH SPEED SEN/CIRC*6	2	×	EC-390
P0506	0506	ISC SYSTEM	2	×	EC-392
P0507	0507	ISC SYSTEM	2	×	EC-394
P0550	0550	PW ST P SEN/CIRC	2	—	EC-396

INDEX FOR DTC

[VQ35DE]

DTC*1		Items (CONSULT-II screen terms)	Trip	MIL lighting up	Reference page
CONSULT-II GST*2	ECM*3				
P0605	0605	ECM	1 or 2	× or —	EC-401
P0705	0705	PNP SW/CIRC	2	×	AT-112
P0710	0710	ATF TEMP SEN/CIRC	2	×	AT-139
P0720	0720	VEH SPD SEN/CIR AT*6	2	×	AT-116
P0725	0725	ENGINE SPEED SIG	2	×	AT-121
P0740	0740	TCC SOLENOID/CIRC	2	×	AT-123
P0744	0744	A/T TCC S/V FNCTN	2	×	AT-125
P0745	0745	L/PRESS SOL/CIRC	2	×	AT-127
P1065	1065	ECM BACK UP/CIRCUIT	2	×	EC-404
P1111	1111	INT/V TIM V/CIR-B1	2	×	EC-408
P1121	1121	ETC ACTR	1	×	EC-415
P1122	1122	ETC FUNCTION/CIRC	1	×	EC-417
P1124	1124	ETC MOT PWR	1	×	EC-423
P1126	1126	ETC MOT PWR	1	×	EC-423
P1128	1128	ETC MOT	1	×	EC-428
P1136	1136	INT/V TIM V/CIR-B2	2	×	EC-408
P1143	1143	HO2S1 (B1)	2	×	EC-433
P1144	1144	HO2S1 (B1)	2	×	EC-439
P1146	1146	HO2S2 (B1)	2	×	EC-446
P1147	1147	HO2S2 (B1)	2	×	EC-457
P1148	1148	CLOSED LOOP-B1	1	×	EC-468
P1163	1163	HO2S1 (B2)	2	×	EC-433
P1164	1164	HO2S1 (B2)	2	×	EC-439
P1166	1166	HO2S2 (B2)	2	×	EC-446
P1167	1167	HO2S2 (B2)	2	×	EC-457
P1168	1168	CLOSED LOOP-B2	1	×	EC-468
P1211	1211	TCS C/U FUNCTN	2	—	EC-470
P1212	1212	TCS/CIRC	2	—	EC-471
P1217	1217	ENG OVER TEMP	1	×	EC-472
P1225	1225	CTP LEARNING	2	—	EC-485
P1226	1226	CTP LEARNING	2	—	EC-487
P1229	1229	SENSOR POWER/CIRC	1	×	EC-489
P1444	1444	PURG VOLUME CONT/V	2	×	EC-494
P1446	1446	VENT CONTROL VALVE	2	×	EC-502
P1564	1564	ASCD SW*7	1	—	EC-508, EC-515
P1568	1568	ACC COMMAND VALUE*8	1	—	EC-521
P1572	1572	ASCD BRAKE SW*7	1	—	EC-522, EC-532
P1574	1574	ASCD VHL SPD SEN*7	1	—	EC-541, EC-543
P1610 - P1615	1610 - 1615	NATS MALFUNCTION	2	—	EC-68
P1705	1705	TP SEN/CIRC A/T	1	×	AT-136
P1706	1706	P-N POS SW/CIRCUIT	2	×	EC-545
P1716	1716	TURBINE REV S/CIRC	2	×	AT-143

INDEX FOR DTC

[VQ35DE]

DTC*1		Items (CONSULT-II screen terms)	Trip	MIL lighting up	Reference page
CONSULT-II GST*2	ECM*3				
P1730	1730	A/T INTERLOCK	1	×	AT-147
P1752	1752	I/C SOLENOID/CIRC	1	×	AT-152
P1754	1754	I/C SOLENOID FNCTN	1	×	AT-154
P1757	1757	FR/B SOLENOID/CIRC	1	×	AT-156
P1759	1759	FR/B SOLENOID FNCT	1	×	AT-158
P1762	1762	D/C SOLENOID/CIRC	1	×	AT-160
P1764	1764	D/C SOLENOID FNCTN	1	×	AT-162
P1767	1767	HLR/C SOL/CIRC	1	×	AT-164
P1769	1769	HLR/C SOL FNCTN	1	×	AT-166
P1772	1772	LC/B SOLENOID/CIRC	1	×	AT-168
P1774	1774	LC/B SOLENOID FNCT	1	×	AT-170
P1805	1805	BRAKE SW/CIRCUIT	2	—	EC-550
P2122	2122	APP SEN 1/CIRC	1	×	EC-555
P2123	2123	APP SEN 1/CIRC	1	×	EC-555
P2127	2127	APP SEN 2/CIRC	1	×	EC-562
P2128	2128	APP SEN 2/CIRC	1	×	EC-562
P2135	2135	TP SENSOR	1	×	EC-569
P2138	2138	APP SENSOR	1	×	EC-576

*1: 1st trip DTC No. is the same as DTC No.

*2: This number is prescribed by SAE J2012.

*3: In Diagnostic Test Mode II (Self-diagnostic results), this number is controlled by NISSAN.

*4: When engine is running.

*5: The troubleshooting for this DTC needs CONSULT-II.

*6: When the fail-safe operations for both self-diagnoses occur, the MIL illuminates.

*7: For models with ICC or ASCD system.

*8: For models with ICC system.

PRECAUTIONS

PF0:00001

Precautions for Supplemental Restraint System (SRS) “AIR BAG” and “SEAT BELT PRE-TENSIONER”

ABS00A2R

The Supplemental Restraint System such as “AIR BAG” and “SEAT BELT PRE-TENSIONER”, used along with a front seat belt, helps to reduce the risk or severity of injury to the driver and front passenger for certain types of collision. This system includes seat belt switch inputs and dual stage front air bag modules. The SRS system uses the seat belt switches to determine the front air bag deployment, and may only deploy one front air bag, depending on the severity of a collision and whether the front occupants are belted or unbelted. Information necessary to service the system safely is included in the SRS and SB section of this Service Manual.

WARNING:

- To avoid rendering the SRS inoperative, which could increase the risk of personal injury or death in the event of a collision which would result in air bag inflation, all maintenance must be performed by an authorized NISSAN/INFINITI dealer.
- Improper maintenance, including incorrect removal and installation of the SRS, can lead to personal injury caused by unintentional activation of the system. For removal of Spiral Cable and Air Bag Module, see the SRS section.
- Do not use electrical test equipment on any circuit related to the SRS unless instructed to in this Service Manual. SRS wiring harnesses can be identified by yellow and/or orange harnesses or harness connectors.

On Board Diagnostic (OBD) System of Engine and A/T

ABS006JZ

The ECM has an on board diagnostic system. It will light up the malfunction indicator lamp (MIL) to warn the driver of a malfunction causing emission deterioration.

CAUTION:

- Be sure to turn the ignition switch OFF and disconnect the negative battery cable before any repair or inspection work. The open/short circuit of related switches, sensors, solenoid valves, etc. will cause the MIL to light up.
- Be sure to connect and lock the connectors securely after work. A loose (unlocked) connector will cause the MIL to light up due to the open circuit. (Be sure the connector is free from water, grease, dirt, bent terminals, etc.)
- Certain systems and components, especially those related to OBD, may use a new style slide-locking type harness connector. For description and how to disconnect, refer to [PG-74, "HARNES CONNECTOR"](#).
- Be sure to route and secure the harnesses properly after work. The interference of the harness with a bracket, etc. may cause the MIL to light up due to the short circuit.
- Be sure to connect rubber tubes properly after work. A misconnected or disconnected rubber tube may cause the MIL to light up due to the malfunction of the EVAP system or fuel injection system, etc.
- Be sure to erase the unnecessary malfunction information (repairs completed) from the ECM and TCM (Transmission control module) before returning the vehicle to the customer.

Precaution

ABS006K0

- Always use a 12 volt battery as power source.
- Do not attempt to disconnect battery cables while engine is running.
- Before connecting or disconnecting the ECM harness connector, turn ignition switch OFF and disconnect negative battery cable. Failure to do so may damage the ECM because battery voltage is applied to ECM even if ignition switch is turned OFF.
- Before removing parts, turn ignition switch OFF and then disconnect negative battery cable.

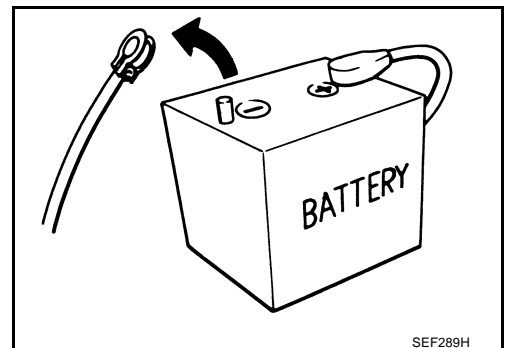

PRECAUTIONS

[VQ35DE]

- Do not disassemble ECM.
- If a battery cable is disconnected, the memory will return to the ECM value.
The ECM will now start to self-control at its initial value. Engine operation can vary slightly when the terminal is disconnected. However, this is not an indication of a malfunction. Do not replace parts because of a slight variation.

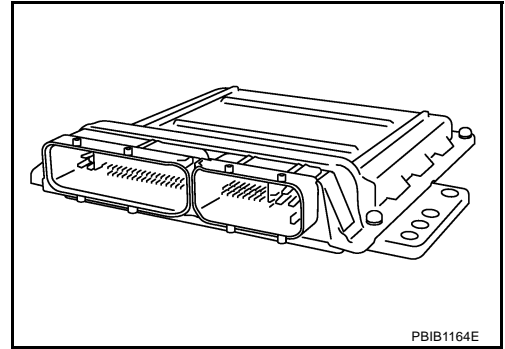

- When connecting ECM harness connector, fasten it securely with a lever as far as it will go as shown in the figure.

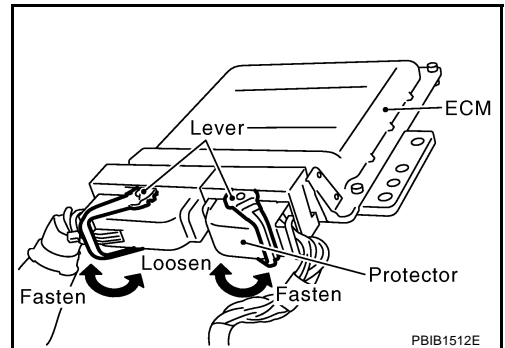

- When connecting or disconnecting pin connectors into or from ECM, take care not to damage pin terminals (bend or break).
Make sure that there are not any bends or breaks on ECM pin terminal, when connecting pin connectors.

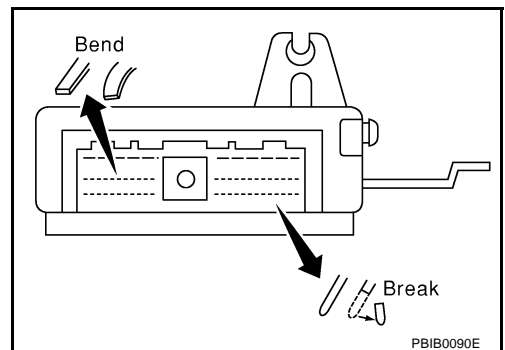

- Securely connect ECM harness connectors.
A poor connection can cause an extremely high (surge) voltage to develop in coil and condenser, thus resulting in damage to ICs.
- Keep engine control system harness at least 10 cm (4 in) away from adjacent harness, to prevent engine control system malfunctions due to receiving external noise, degraded operation of ICs, etc.
- Keep engine control system parts and harness dry.
- Before replacing ECM, perform "ECM Terminals and Reference Value" inspection and make sure ECM functions properly. Refer to [EC-100](#).
- Handle mass air flow sensor carefully to avoid damage.
- Do not disassemble mass air flow sensor.
- Do not clean mass air flow sensor with any type of detergent.
- Do not disassemble electric throttle control actuator.
- Even a slight leak in the air intake system can cause serious incidents.
- Do not shock or jar the camshaft position sensor (PHASE), crankshaft position sensor (POS).

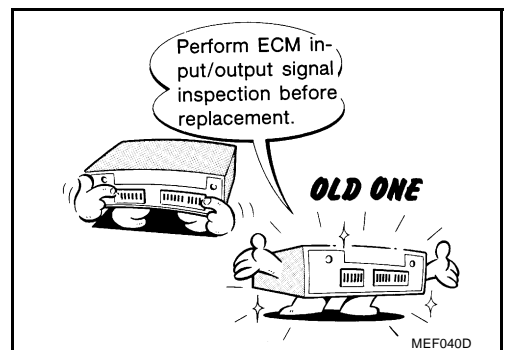

PRECAUTIONS

[VQ35DE]

- After performing each TROUBLE DIAGNOSIS, perform DTC Confirmation Procedure or Overall Function Check. The DTC should not be displayed in the DTC Confirmation Procedure if the repair is completed. The Overall Function Check should be a good result if the repair is completed.

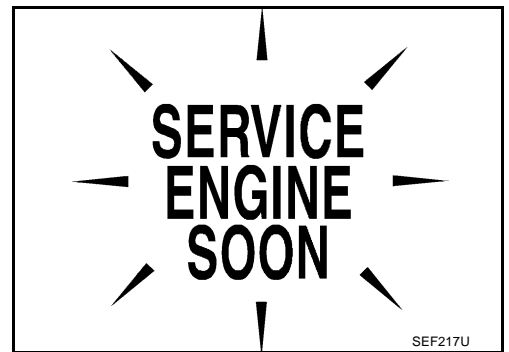

- When measuring ECM signals with a circuit tester, never allow the two tester probes to contact. Accidental contact of probes will cause a short circuit and damage the ECM power transistor.
- Do not use ECM ground terminals when measuring input/output voltage. Doing so may result in damage to the ECM's transistor. Use a ground other than ECM terminals, such as the ground.

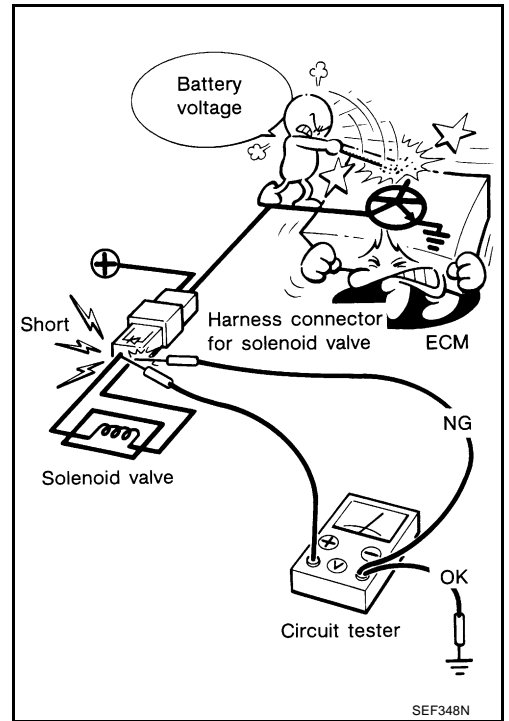

- B1 indicates the bank 1, B2 indicates the bank 2 as shown in the figure.

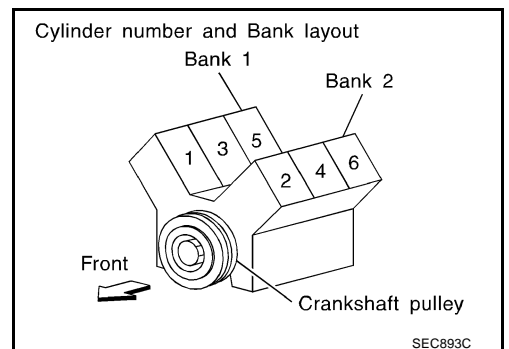

A
EC
C
D
E
F
G
H
I
J
K
L
M

PRECAUTIONS

[VQ35DE]

- Do not operate fuel pump when there is no fuel in lines.
- Tighten fuel hose clamps to the specified torque.

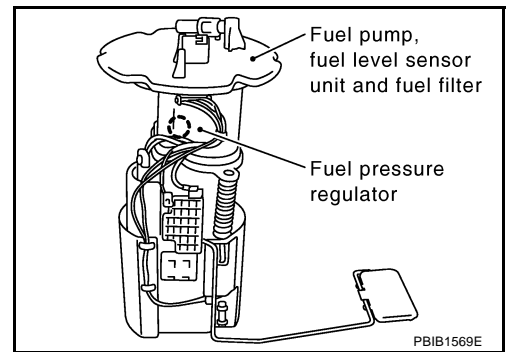

- Do not depress accelerator pedal when starting.
- Immediately after starting, do not rev up engine unnecessarily.
- Do not rev up engine just prior to shutdown.

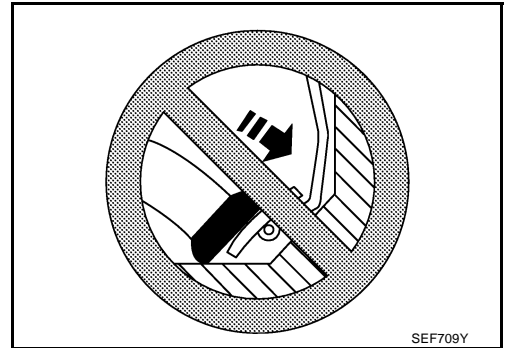

- When installing C.B. ham radio or a mobile phone, be sure to observe the following as it may adversely affect electronic control systems depending on installation location.
 - Keep the antenna as far as possible from the electronic control units.
 - Keep the antenna feeder line more than 20 cm (8 in) away from the harness of electronic controls. Do not let them run parallel for a long distance.
 - Adjust the antenna and feeder line so that the standing-wave ratio can be kept smaller.
 - Be sure to ground the radio to vehicle body.

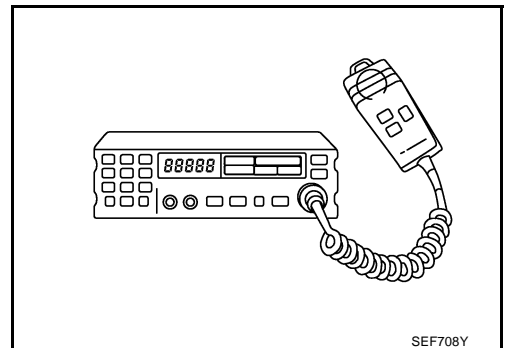

Wiring Diagrams and Trouble Diagnosis

ABS006K1

When you read wiring diagrams, refer to the following:

- [GI-15, "How to Read Wiring Diagrams"](#)
- [PG-3, "POWER SUPPLY ROUTING CIRCUIT"](#) for power distribution circuit

When you perform trouble diagnosis, refer to the following:

- [GI-11, "HOW TO FOLLOW TEST GROUPS IN TROUBLE DIAGNOSES"](#)
- [GI-27, "How to Perform Efficient Diagnosis for an Electrical Incident"](#)

PREPARATION

PFP:00002

Special Service Tools

ABS006K2

The actual shapes of Kent-Moore tools may differ from those of special service tools illustrated here.

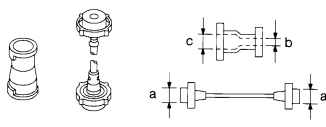
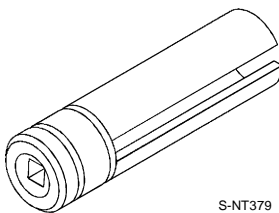
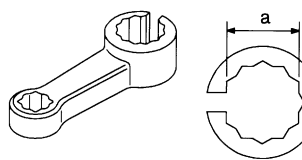
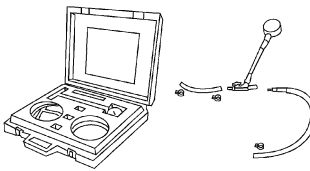
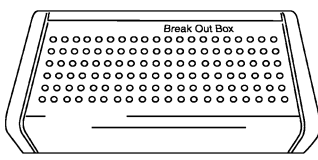
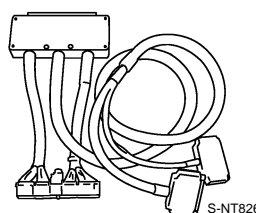
Tool number (Kent-Moore No.) Tool name	Description
EG17650301 (J-33984-A) Radiator cap tester adapter  <p style="text-align: center;">S-NT564</p>	Adapting radiator cap tester to radiator cap and radiator filler neck a: 28 (1.10) dia. b: 31.4 (1.236) dia. c: 41.3 (1.626) dia. Unit: mm (in)
KV10117100 (J-36471-A) Heated oxygen sensor wrench  <p style="text-align: center;">S-NT379</p>	Loosening or tightening heated oxygen sensors with 22 mm (0.87 in) hexagon nut
KV10114400 (J-38365) Heated oxygen sensor wrench  <p style="text-align: center;">S-NT636</p>	Loosening or tightening heated oxygen sensors a: 22 mm (0.87 in)
(J-44321) Fuel pressure gauge kit  <p style="text-align: center;">LEC642</p>	Checking fuel pressure
KV109E0010 (J-46209) Break-out box  <p style="text-align: center;">S-NT825</p>	Measuring the ECM signals with a circuit tester
KV109E0080 (J-45819) Y-cable adapter  <p style="text-align: center;">S-NT826</p>	Measuring the ECM signals with a circuit tester

A
EC
C
D
E
F
G
H
I
J
K
L
M

Commercial Service Tools

ABS006K3

Tool name (Kent-Moore No.)	Description
Leak detector i.e.: (J-41416)	Locating the EVAP leak
EVAP service port adapter i.e.: (J-41413-OBD)	Applying positive pressure through EVAP service port
Fuel filler cap adapter i.e.: (MLR-8382)	Checking fuel tank vacuum relief valve opening pressure
Socket wrench	Removing and installing engine coolant temperature sensor
Oxygen sensor thread cleaner i.e.: (J-43897-18) (J-43897-12)	Reconditioning the exhaust system threads before installing a new oxygen sensor. Use with anti-seize lubricant shown below. a: 18 mm diameter with pitch 1.5 mm for Zirconia Oxygen Sensor b: 12 mm diameter with pitch 1.25 mm for Titania Oxygen Sensor
Anti-seize lubricant i.e.: (Permatex™ 133AR or equivalent meeting MIL specification MIL-A-907)	Lubricating oxygen sensor thread cleaning tool when reconditioning exhaust system threads.

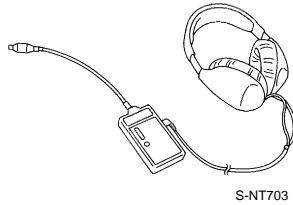

S-NT703

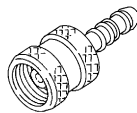

S-NT704

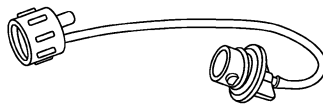

S-NT815

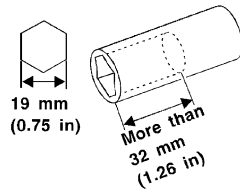

S-NT705

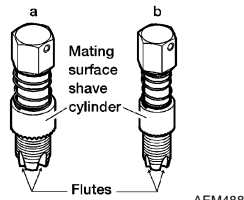

AEM488



S-NT779

ENGINE CONTROL SYSTEM

PFP:23710

System Diagram

ABS006K4

A
C
D
E
F
G
H
I
J
K
L
M

EC

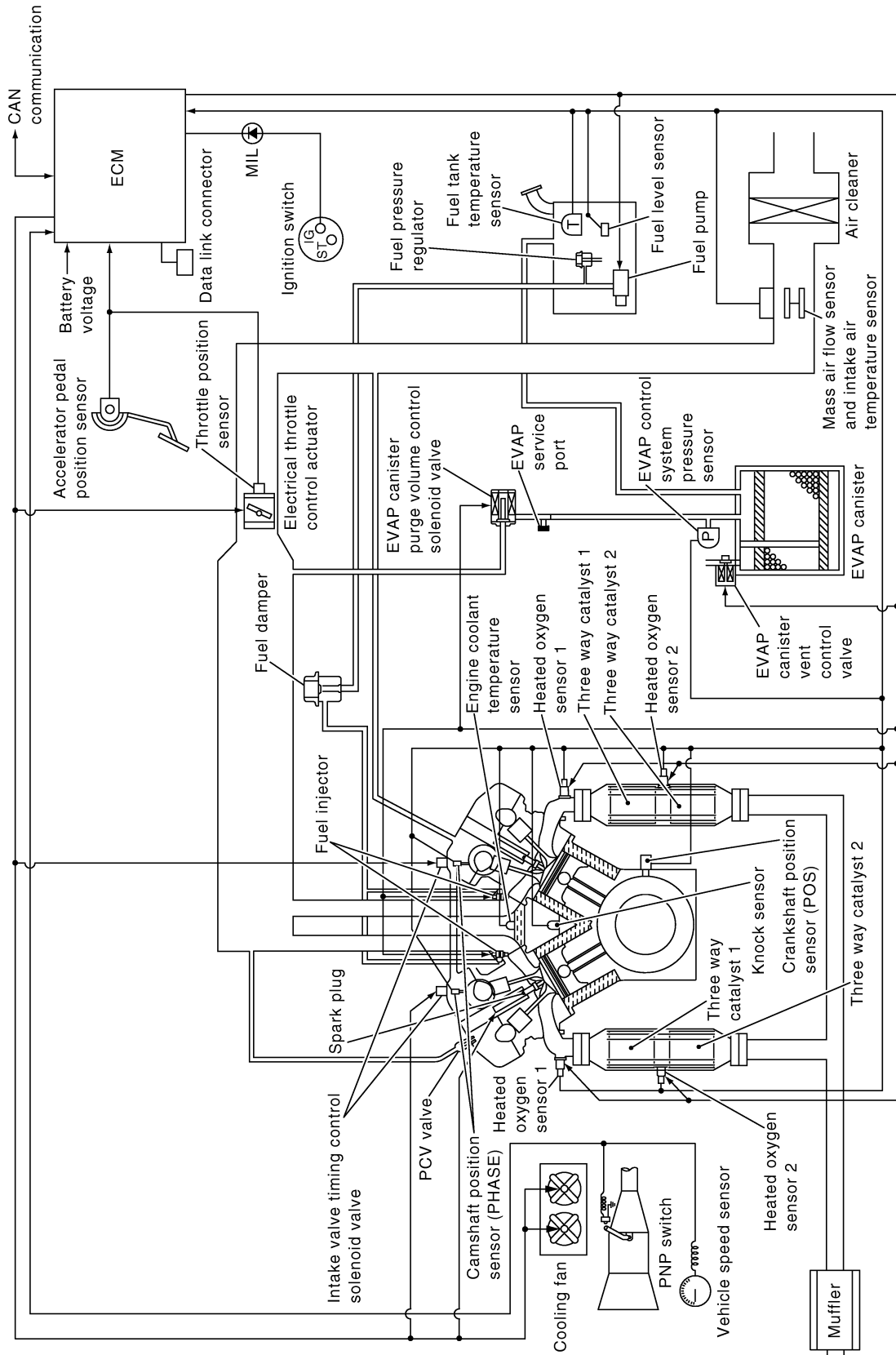

PBIB2294E

Vacuum Hose Drawing

ABS006K5

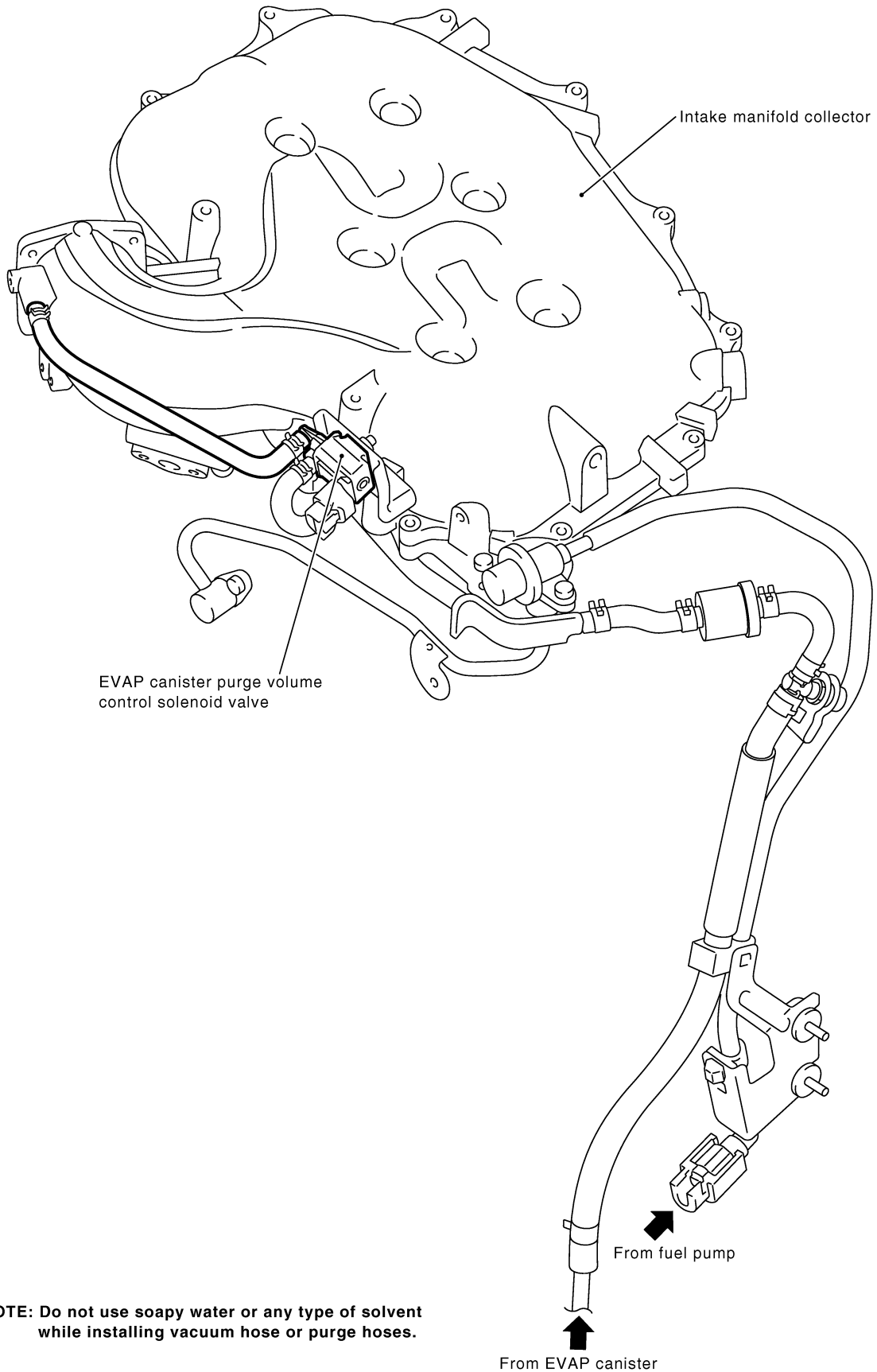

NOTE: Do not use soapy water or any type of solvent while installing vacuum hose or purge hoses.

Refer to [EC-29, "System Diagram"](#) for Vacuum Control System.

PBIB2000E

ENGINE CONTROL SYSTEM

[VQ35DE]

ABS006K6

System Chart

Input (Sensor)	ECM Function	Output (Actuator)
● Camshaft position sensor (PHASE)	Fuel injection & mixture ratio control	Fuel injector
● Crankshaft position sensor (POS)	Electronic ignition system	Power transistor
● Mass air flow sensor	Fuel pump control	Fuel pump relay
● Engine coolant temperature sensor	ICC vehicle speed control	Electric throttle control actuator
● Heated oxygen sensor 1	ASCD vehicle speed control	Electric throttle control actuator
● Throttle position sensor	On board diagnostic system	MIL (On the instrument panel)*4
● Accelerator pedal position sensor	Heated oxygen sensor 1 heater control	Heated oxygen sensor 1 heater
● Park/neutral position (PNP) switch	Heated oxygen sensor 2 heater control	Heated oxygen sensor 2 heater
● Intake air temperature sensor	EVAP canister purge flow control	EVAP canister purge volume control solenoid valve
● Power steering pressure sensor	Air conditioning cut control	Air conditioner relay*4
● Ignition switch	Cooling fan control	Cooling fan relay*4
● Battery voltage		
● Knock sensor		
● Refrigerant pressure sensor		
● Stop lamp switch		
● ICC steering switch		
● ICC brake switch		
● ASCD steering switch		
● ASCD brake switch		
● Fuel level sensor*1 *3		
● EVAP control system pressure sensor		
● Fuel tank temperature sensor*1	ON BOARD DIAGNOSIS for EVAP system	EVAP canister vent control valve
● Heated oxygen sensor 2*2		
● TCM (Transmission control module)*3		
● ABS actuator and electric unit (control unit)*3		
● ICC unit*3		
● Air conditioner switch*3		
● Wheel sensor*3		
● Electrical load signal*3		

*1: This sensor is not used to control the engine system. This is used only for the on board diagnosis.

*2: This sensor is not used to control the engine system under normal conditions.

*3: This input signal is sent to the ECM through CAN communication line.

*4: This output signal is sent from the ECM through CAN communication line.

A
EC
C
D
E
F
G
H
I
J
K
L
M

Multipoint Fuel Injection (MFI) System INPUT/OUTPUT SIGNAL CHART

ABS006K7

Sensor	Input Signal to ECM	ECM function	Actuator
Crankshaft position sensor (POS)	Engine speed*3	Fuel injection & mixture ratio control	Fuel injector
Camshaft position sensor (PHASE)	Piston position		
Mass air flow sensor	Amount of intake air		
Engine coolant temperature sensor	Engine coolant temperature		
Heated oxygen sensor 1	Density of oxygen in exhaust gas		
Throttle position sensor	Throttle position		
Accelerator pedal position sensor	Accelerator pedal position		
Park/neutral position (PNP) switch	Gear position		
Knock sensor	Engine knocking condition		
Battery	Battery voltage*3		
Power steering pressure sensor	Power steering operation		
Heated oxygen sensor 2*1	Density of oxygen in exhaust gas		
Air conditioner switch*2	Air conditioner operation		
Wheel sensor*2	Vehicle speed		

*1: This sensor is not used to control the engine system under normal conditions.

*2: This signal is sent to the ECM through CAN communication line.

*3: ECM determines the start signal status by the signals of engine speed and battery voltage.

SYSTEM DESCRIPTION

The amount of fuel injected from the fuel injector is determined by the ECM. The ECM controls the length of time the valve remains open (injection pulse duration). The amount of fuel injected is a program value in the ECM memory. The program value is preset by engine operating conditions. These conditions are determined by input signals (for engine speed and intake air) from both the crankshaft position sensor and the mass air flow sensor.

VARIOUS FUEL INJECTION INCREASE/DECREASE COMPENSATION

In addition, the amount of fuel injected is compensated to improve engine performance under various operating conditions as listed below.

<Fuel increase>

- During warm-up
- When starting the engine
- During acceleration
- Hot-engine operation
- When selector lever is changed from N to D
- High-load, high-speed operation

<Fuel decrease>

- During deceleration
- During high engine speed operation

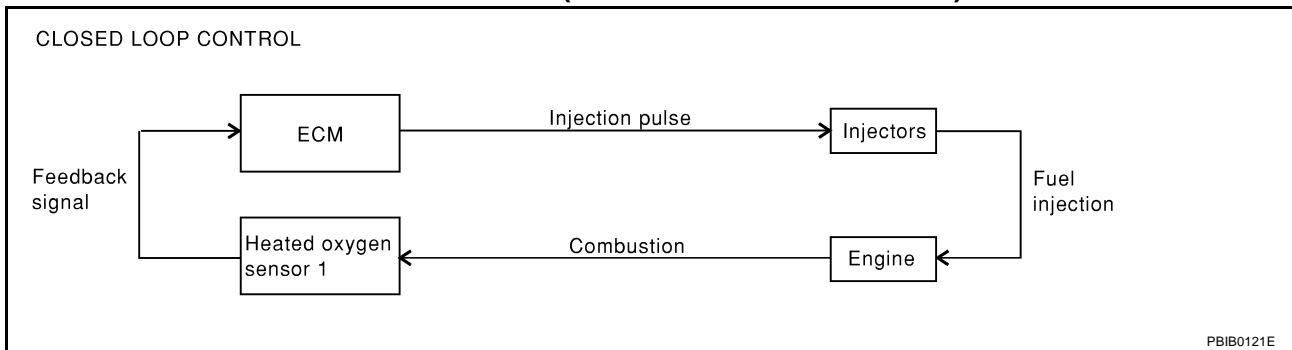
MIXTURE RATIO FEEDBACK CONTROL (CLOSED LOOP CONTROL)

The mixture ratio feedback system provides the best air-fuel mixture ratio for driveability and emission control. The three way catalyst 1 can then better reduce CO, HC and NOx emissions. This system uses heated oxygen sensor 1 in the exhaust manifold to monitor whether the engine operation is rich or lean. The ECM adjusts the injection pulse width according to the sensor voltage signal. For more information about heated oxygen sensor 1, refer to [EC-205](#). This maintains the mixture ratio within the range of stoichiometric (ideal air-fuel mixture).

This stage is referred to as the closed loop control condition.

Heated oxygen sensor 2 is located downstream of the three way catalyst 1. Even if the switching characteristics of heated oxygen sensor 1 shift, the air-fuel ratio is controlled to stoichiometric by the signal from heated oxygen sensor 2.

Open Loop Control

The open loop system condition refers to when the ECM detects any of the following conditions. Feedback control stops in order to maintain stabilized fuel combustion.

- Deceleration and acceleration
- High-load, high-speed operation
- Malfunction of heated oxygen sensor 1 or its circuit
- Insufficient activation of heated oxygen sensor 1 at low engine coolant temperature
- High engine coolant temperature
- During warm-up
- After shifting from N to D
- When starting the engine

MIXTURE RATIO SELF-LEARNING CONTROL

The mixture ratio feedback control system monitors the mixture ratio signal transmitted from heated oxygen sensor 1. This feedback signal is then sent to the ECM. The ECM controls the basic mixture ratio as close to the theoretical mixture ratio as possible. However, the basic mixture ratio is not necessarily controlled as originally designed. Both manufacturing differences (i.e., mass air flow sensor hot wire) and characteristic changes during operation (i.e., injector clogging) directly affect mixture ratio.

Accordingly, the difference between the basic and theoretical mixture ratios is monitored in this system. This is then computed in terms of "injection pulse duration" to automatically compensate for the difference between the two ratios.

"Fuel trim" refers to the feedback compensation value compared against the basic injection duration. Fuel trim includes short term fuel trim and long term fuel trim.

"Short term fuel trim" is the short-term fuel compensation used to maintain the mixture ratio at its theoretical value. The signal from heated oxygen sensor 1 indicates whether the mixture ratio is RICH or LEAN compared to the theoretical value. The signal then triggers a reduction in fuel volume if the mixture ratio is rich, and an increase in fuel volume if it is lean.

"Long term fuel trim" is overall fuel compensation carried out long-term to compensate for continual deviation of the short term fuel trim from the central value. Such deviation will occur due to individual engine differences, wear over time and changes in the usage environment.

FUEL INJECTION TIMING

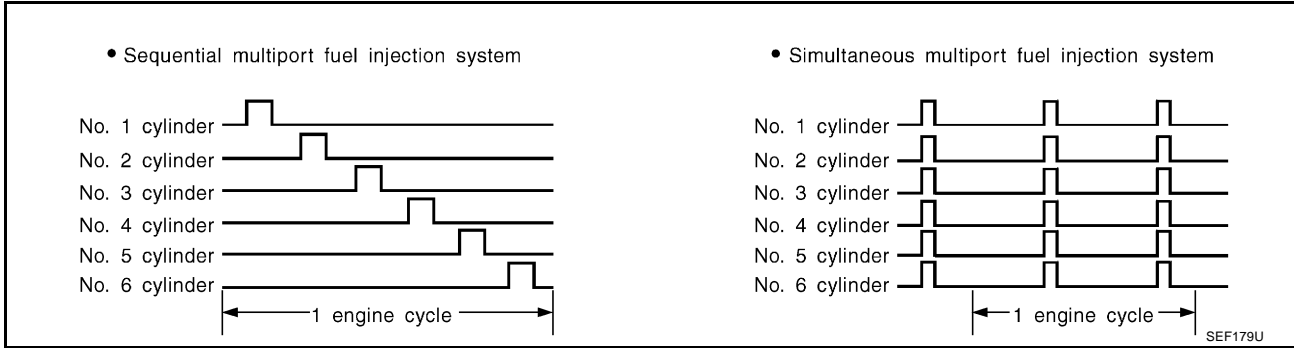

Two types of systems are used.

Sequential Multiport Fuel Injection System

Fuel is injected into each cylinder during each engine cycle according to the firing order. This system is used when the engine is running.

Simultaneous Multiport Fuel Injection System

Fuel is injected simultaneously into all six cylinders twice each engine cycle. In other words, pulse signals of the same width are simultaneously transmitted from the ECM.

The six injectors will then receive the signals two times for each engine cycle.

This system is used when the engine is being started and/or if the fail-safe system (CPU) is operating.

FUEL SHUT-OFF

Fuel to each cylinder is cut off during deceleration or operation of the engine at excessively high speeds.

Electronic Ignition (EI) System INPUT/OUTPUT SIGNAL CHART

ABS006K8

Sensor	Input Signal to ECM	ECM function	Actuator
Crankshaft position sensor (POS)	Engine speed*2 Piston position	Ignition timing control	Power transistor
Camshaft position sensor (PHASE)			
Mass air flow sensor	Amount of intake air		
Engine coolant temperature sensor	Engine coolant temperature		
Throttle position sensor	Throttle position		
Accelerator pedal position sensor	Accelerator pedal position		
Knock sensor	Engine knocking		
Park/neutral position (PNP) switch	Gear position		
Battery	Battery voltage*2		
Wheel sensor*1	Vehicle speed		

*1: This signal is sent to the ECM through CAN communication line.

*2: ECM determines the start signal status by the signals of engine speed and battery voltage.

SYSTEM DESCRIPTION

The ignition timing is controlled by the ECM to maintain the best air-fuel ratio for every running condition of the engine. The ignition timing data is stored in the ECM. This data forms the map shown.

The ECM receives information such as the injection pulse width and camshaft position sensor signal. Computing this information, ignition signals are transmitted to the power transistor.

e.g., N: 1,800 rpm, Tp: 1.50 msec

A °BTDC

During the following conditions, the ignition timing is revised by the ECM according to the other data stored in the ECM.

- At starting
- During warm-up

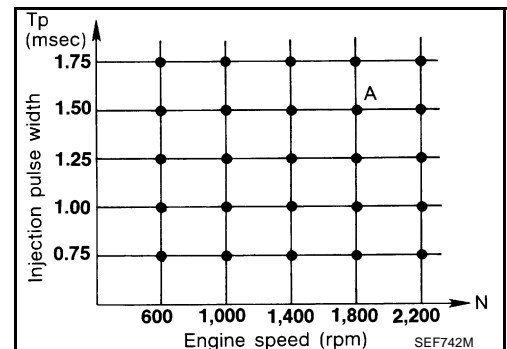

- At idle
- At low battery voltage
- During acceleration

The knock sensor retard system is designed only for emergencies. The basic ignition timing is programmed within the anti-knocking zone, if recommended fuel is used under dry conditions. The retard system does not operate under normal driving conditions. If engine knocking occurs, the knock sensor monitors the condition. The signal is transmitted to the ECM. The ECM retards the ignition timing to eliminate the knocking condition.

Air Conditioning Cut Control INPUT/OUTPUT SIGNAL CHART

ABS006K9

Sensor	Input Signal to ECM	ECM function	Actuator
Air conditioner switch*1	Air conditioner ON signal	Air conditioner cut control	Air conditioner relay
Throttle position sensor	Throttle position		
Accelerator pedal position sensor	Accelerator pedal position		
Crankshaft position sensor (POS) Camshaft position sensor (PHASE)	Engine speed*2		
Engine coolant temperature sensor	Engine coolant temperature		
Battery	Battery voltage*2		
Refrigerant pressure sensor	Refrigerant pressure		
Power steering pressure sensor	Power steering operation		
Wheel sensor*1	Vehicle speed		

*1: This signal is sent to the ECM through CAN communication line.

*2: ECM determines the start signal status by the signals of engine speed and battery voltage.

SYSTEM DESCRIPTION

This system improves engine operation when the air conditioner is used. Under the following conditions, the air conditioner is turned off.

- When the accelerator pedal is fully depressed.
- When cranking the engine.
- At high engine speeds.
- When the engine coolant temperature becomes excessively high.
- When operating power steering during low engine speed or low vehicle speed.
- When engine speed is excessively low.
- When refrigerant pressure is excessively low or high.

Fuel Cut Control (at No Load and High Engine Speed) INPUT/OUTPUT SIGNAL CHART

ABS006KA

Sensor	Input Signal to ECM	ECM function	Actuator
Park/neutral position (PNP) switch	Neutral position	Fuel cut control	Fuel injector
Accelerator pedal position sensor	Accelerator pedal position		
Engine coolant temperature sensor	Engine coolant temperature		
Crankshaft position sensor (POS) Camshaft position sensor (PHASE)	Engine speed		
Wheel sensor*1	Vehicle speed		

*1: This signal is sent to the ECM through CAN communication line.

SYSTEM DESCRIPTION

If the engine speed is above 1,800 rpm under no load (for example, the shift position is neutral and engine speed is over 1,800 rpm) fuel will be cut off after some time. The exact time when the fuel is cut off varies based on engine speed.

Fuel cut will be operated until the engine speed reaches 1,500 rpm, then fuel cut will be cancelled.

NOTE:

This function is different from deceleration control listed under "Multiport Fuel Injection (MFI) System", [EC-32](#) .

**CAN communication
SYSTEM DESCRIPTION**

ABS006KB

CAN (Controller Area Network) is a serial communication line for real time application. It is an on-vehicle multiplex communication line with high data communication speed and excellent error detection ability. Many electronic control units are equipped onto a vehicle, and each control unit shares information and links with other control units during operation (not independent). In CAN communication, control units are connected with 2 communication lines (CAN H line, CAN L line) allowing a high rate of information transmission with less wiring. Each control unit transmits/receives data but selectively reads required data only. Refer to [LAN-6, "CAN Communication Unit"](#) , about CAN communication for detail.

BASIC SERVICE PROCEDURE

PFP:00018

Idle Speed and Ignition Timing Check IDLE SPEED

ABS006KC

With CONSULT-II

Check idle speed in "DATA MONITOR" mode with CONSULT-II.

DATA MONITOR	
MONITOR	NO DTC
ENG SPEED	XXX rpm

SEF058Y

With GST

Check idle speed with GST.

IGNITION TIMING

Any of following two methods may be used.

Method A

1. Attach timing light to loop wire as shown.

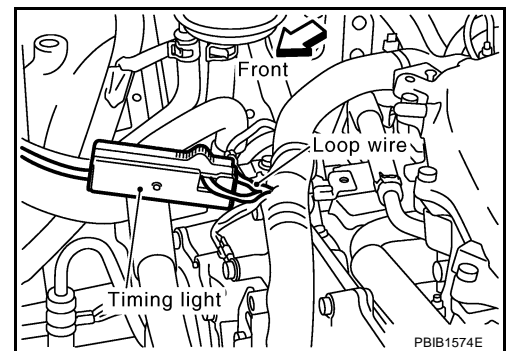

2. Check ignition timing.

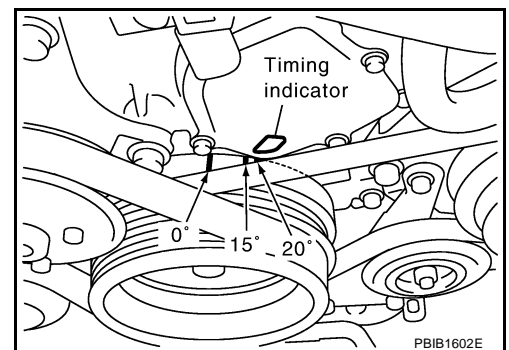

Method B

1. Remove No. 1 ignition coil.

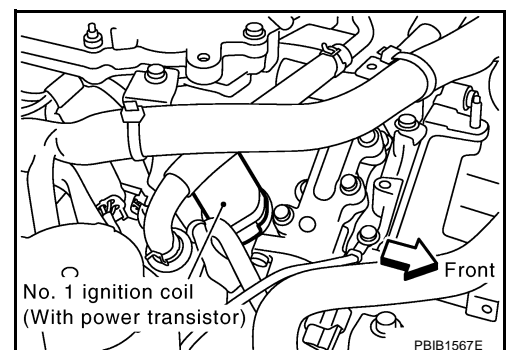

A
EC
C
D
E
F
G
H
I
J
K
L
M

2. Connect No. 1 ignition coil and No. 1 spark plug with suitable high-tension wire as shown, and attach timing light clamp to this wire.

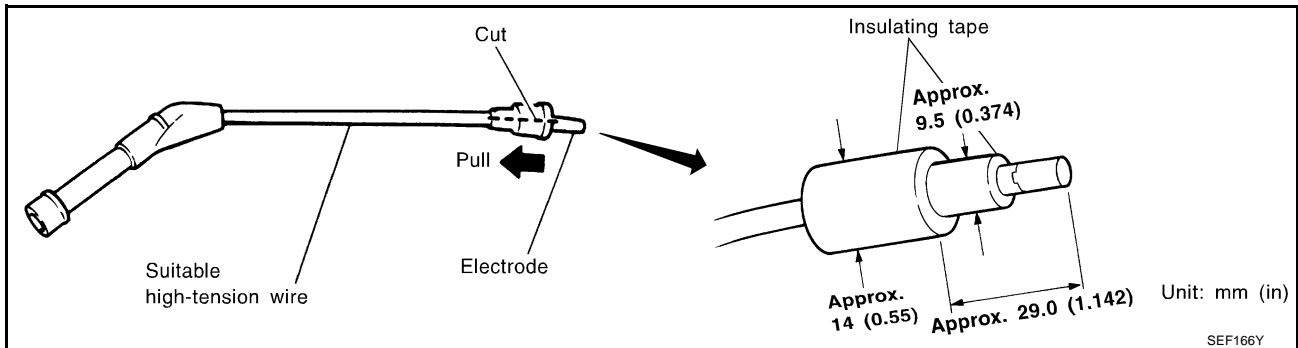
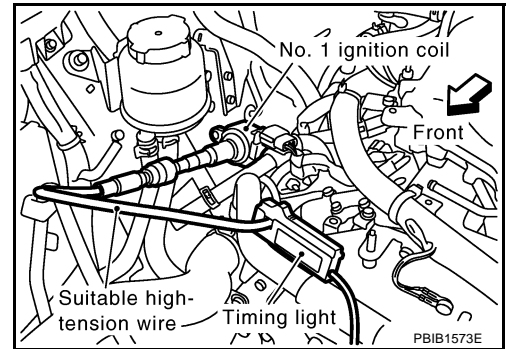

3. Check ignition timing.

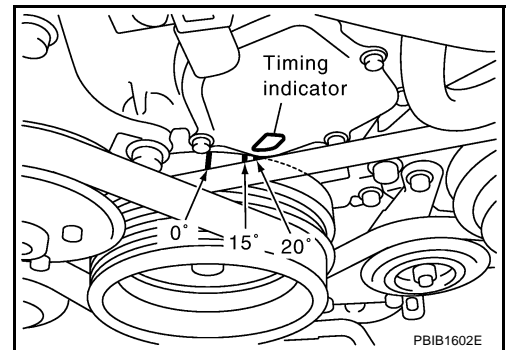

Idle Speed/Ignition Timing/Idle Mixture Ratio Adjustment

ABS006KD

PREPARATION

1. Make sure that the following parts are in good order.
 - Battery
 - Ignition system
 - Engine oil and coolant levels
 - Fuses
 - ECM harness connector
 - Vacuum hoses
 - Air intake system
(Oil filler cap, oil level gauge, etc.)
 - Fuel pressure
 - Engine compression
 - Throttle valve
 - Evaporative emission system
2. On air conditioner equipped models, checks should be carried out while the air conditioner is OFF.
3. On automatic transmission equipped models, when checking idle rpm, ignition timing and mixture ratio, checks should be carried out while shift lever is in N position.
4. When measuring CO percentage, insert probe more than 40 cm (15.7 in) into tail pipe.
5. Turn OFF headlamp, heater blower, rear window defogger.

6. Keep front wheels pointed straight ahead.

OVERALL INSPECTION SEQUENCE

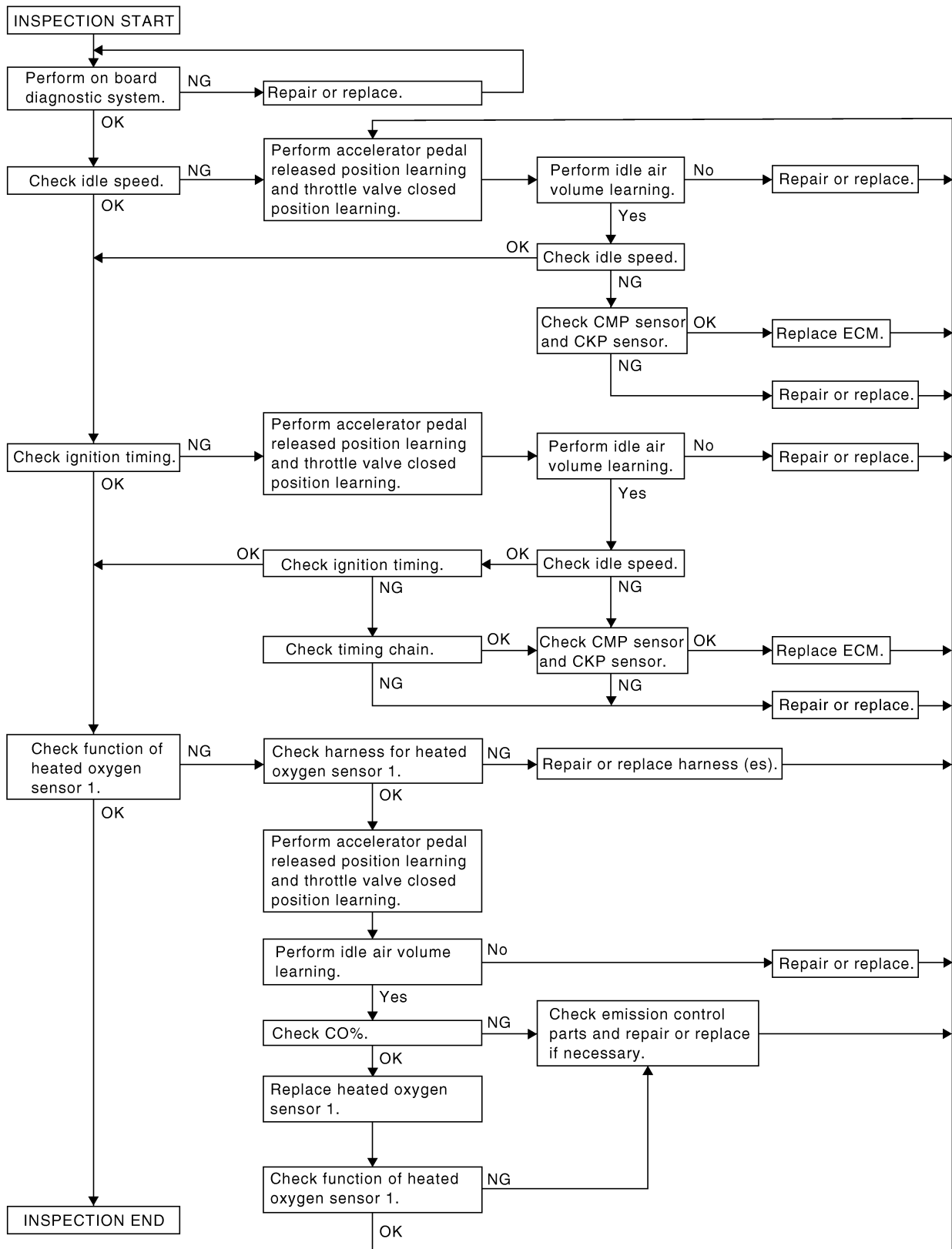

NOTE:
 If a vehicle contains a part which is operating outside of design specifications with no MIL illumination, the part shall not be replaced prior to emission testing unless it is determined that the part has been tampered with or abused in such a way that the diagnostic system cannot reasonably be expected to detect the resulting malfunction.

PBIB2001E

INSPECTION PROCEDURE

1. INSPECTION START

1. Check service records for any recent repairs that may indicate a related malfunction, or a current need for scheduled maintenance.
2. Open engine hood and check the following:
 - Harness connectors for improper connections
 - Wiring harness for improper connections, pinches and cut
 - Vacuum hoses for splits, kinks and improper connections
 - Hoses and ducts for leaks
 - Air cleaner clogging
 - Gasket
3. Confirm that electrical or mechanical loads are not applied.
 - Headlamp switch is OFF.
 - Air conditioner switch is OFF.
 - Rear window defogger switch is OFF.
 - Steering wheel is in the straight-ahead position, etc.
4. Start engine and warm it up until engine coolant temperature indicator points the middle of gauge.
Ensure engine stays below 1,000 rpm.

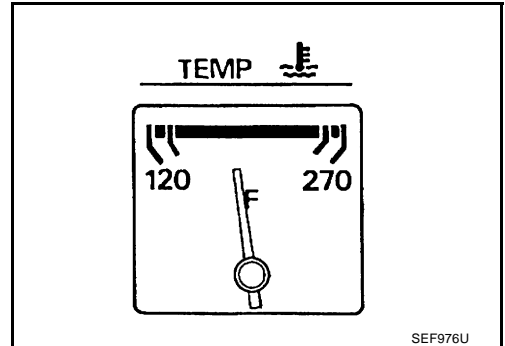
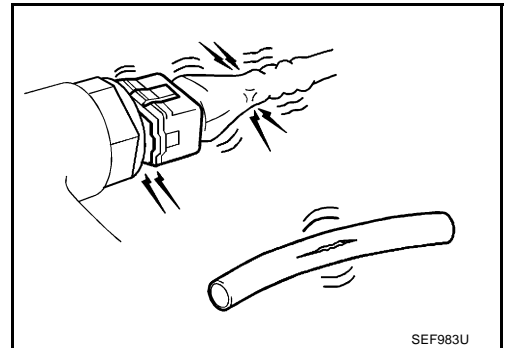

5. Run engine at about 2,000 rpm for about 2 minutes under no-load.
6. Make sure that no DTC is displayed with CONSULT-II or GST.

OK or NG

- OK >> GO TO 3.
 NG >> GO TO 2.

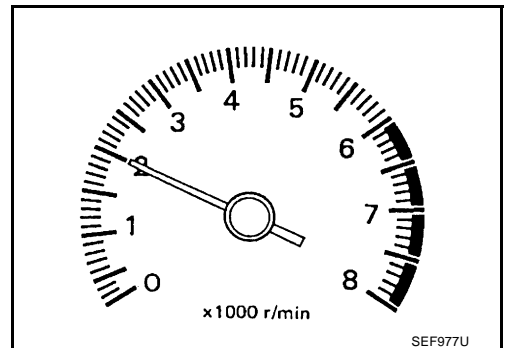

2. REPAIR OR REPLACE

Repair or replace components as necessary according to corresponding Diagnostic Procedure.

>> GO TO 3.

3. CHECK TARGET IDLE SPEED

With CONSULT-II

1. Run engine at about 2,000 rpm for about 2 minutes under no-load.
2. Rev engine (2,000 to 3,000 rpm) two or three times under no-load, then run engine at idle speed for about 1 minute.

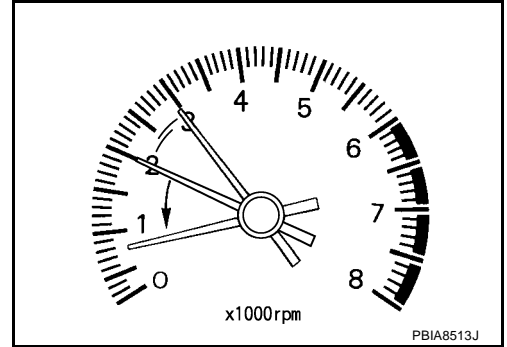

3. Read idle speed in "DATA MONITOR" mode with CONSULT-II.
650 ± 50 rpm (in P or N position)

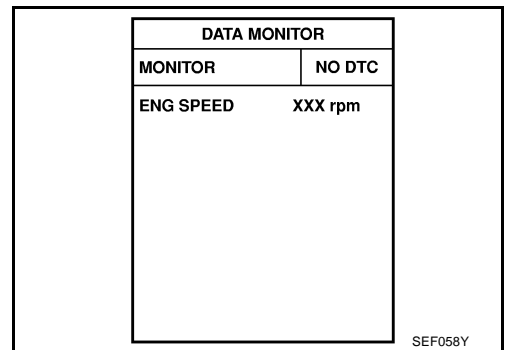

Without CONSULT-II

1. Run engine at about 2,000 rpm for about 2 minutes under no-load.
2. Rev engine (2,000 to 3,000 rpm) two or three times under no-load, then run engine at idle speed for about 1 minute.
3. Check idle speed.

650 ± 50 rpm (in P or N position)

OK or NG

- OK >> GO TO 10.
NG >> GO TO 4.

4. PERFORM ACCELERATOR PEDAL RELEASED POSITION LEARNING

1. Stop engine.
2. Perform [EC-49, "Accelerator Pedal Released Position Learning"](#) .

>> GO TO 5.

5. PERFORM THROTTLE VALVE CLOSED POSITION LEARNING

Perform [EC-49, "Throttle Valve Closed Position Learning"](#) .

>> GO TO 6.

6. PERFORM IDLE AIR VOLUME LEARNING

Perform [EC-49, "Idle Air Volume Learning"](#) .

Is Idle Air Volume Learning carried out successfully?

Yes or No

Yes >> GO TO 7.

No >> 1. Follow the instruction of Idle Air Volume Learning.
2. GO TO 4.

7. CHECK TARGET IDLE SPEED AGAIN

With CONSULT-II

1. Start engine and warm it up to normal operating temperature.
2. Read idle speed in "DATA MONITOR" mode with CONSULT-II.

650 ± 50 rpm (in P or N position)

Without CONSULT-II

1. Start engine and warm it up to normal operating temperature.
2. Check idle speed.

650 ± 50 rpm (in P or N position)

OK or NG

OK >> GO TO 10.

NG >> GO TO 8.

DATA MONITOR	
MONITOR	NO DTC
ENG SPEED	XXX rpm
COOLAN TEMP/S	XXX °C

SEF174Y

8. DETECT MALFUNCTIONING PART

Check the following.

- Check camshaft position sensor (PHASE) and circuit. Refer to [EC-308](#) .
- Check crankshaft position sensor (POS) and circuit. Refer to [EC-302](#) .

OK or NG

OK >> GO TO 9.

NG >> 1. Repair or replace.
2. GO TO 4.

9. CHECK ECM FUNCTION

1. Substitute another known-good ECM to check ECM function. (ECM may be the cause of an incident, but this is a rare case.)
2. Perform initialization of IVIS (NATS) system and registration of IVIS (NATS) ignition key IDs. Refer to [BL-208, "ECM Re-communicating Function"](#) .

>> GO TO 4.

10. CHECK IGNITION TIMING

1. Run engine at idle.
2. Check ignition timing with a timing light.

15 ± 5° BTDC (in P or N position)

OK or NG

- OK (With CONSULT-II) >> GO TO 19.
 OK (Without CONSULT-II) >> GO TO 20.
 NG >> GO TO 11.

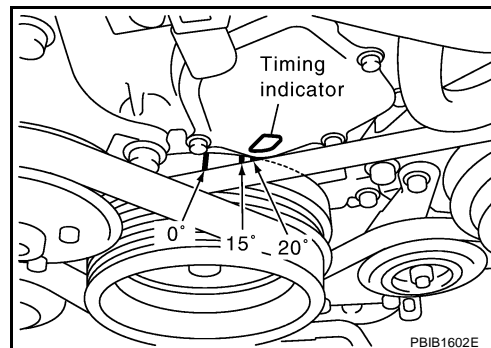

11. PERFORM ACCELERATOR PEDAL RELEASED POSITION LEARNING

1. Stop engine.
2. Perform [EC-49, "Accelerator Pedal Released Position Learning"](#).

>> GO TO 12.

12. PERFORM THROTTLE VALVE CLOSED POSITION LEARNING

Perform [EC-49, "Throttle Valve Closed Position Learning"](#).

>> GO TO 13.

13. PERFORM IDLE AIR VOLUME LEARNING

Perform [EC-49, "Idle Air Volume Learning"](#).

Is Idle Air Volume Learning carried out successfully?

Yes or No

- Yes >> GO TO 14.
 No >> 1. Follow the instruction of Idle Air Volume Learning.
 2. GO TO 4.

14. CHECK TARGET IDLE SPEED AGAIN

With CONSULT-II

1. Start engine and warm it up to normal operating temperature.
2. Read idle speed in "DATA MONITOR" mode with CONSULT-II.

650 ± 50 rpm (in P or N position)

Without CONSULT-II

1. Start engine and warm it up to normal operating temperature.
2. Check idle speed.

650 ± 50 rpm (in P or N position)

OK or NG

- OK >> GO TO 15.
 NG >> GO TO 17.

DATA MONITOR	
MONITOR	NO DTC
ENG SPEED	XXX rpm
COOLAN TEMP/S	XXX °C

SEF174Y

15. CHECK IGNITION TIMING AGAIN

1. Run engine at idle.
2. Check ignition timing with a timing light.

15 ± 5° BTDC (in P or N position)

OK or NG

- OK (With CONSULT-II) >> GO TO 19.
 OK (Without CONSULT-II) >> GO TO 20.
 NG >> GO TO 16.

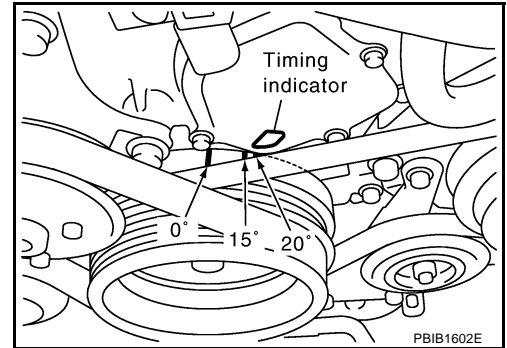

16. CHECK TIMING CHAIN INSTALLATION

Check timing chain installation. Refer to [EM-63, "TIMING CHAIN"](#) .

OK or NG

- OK >> GO TO 17.
 NG >> 1. Repair the timing chain installation.
 2. GO TO 4.

17. DETECT MALFUNCTIONING PART

Check the following.

- Check camshaft position sensor (PHASE) and circuit. Refer to [EC-308](#) .
- Check crankshaft position sensor (POS) and circuit. Refer to [EC-302](#) .

OK or NG

- OK >> GO TO 18.
 NG >> 1. Repair or replace.
 2. GO TO 4.

18. CHECK ECM FUNCTION

1. Substitute another known-good ECM to check ECM function. (ECM may be the cause of an incident, but this is a rare case.)
2. Perform initialization of IVIS (NATS) system and registration of IVIS (NATS) ignition key IDs. Refer to [BL-208, "ECM Re-communicating Function"](#) .

>> GO TO 4.

19. CHECK HEATED OXYGEN SENSOR 1 (BANK 1) SIGNAL

With CONSULT-II

1. Run engine at about 2,000 rpm for about 2 minutes under no-load.
2. See "HO2S1 MNTR (B1)" in "DATA MONITOR" mode.
3. Running engine at 2,000 rpm under no-load (The engine is warmed up to normal operating temperature.), check that the monitor fluctuates between LEAN and RICH more than 5 times during 10 seconds.

1 time: RICH → LEAN → RICH

2 times: RICH → LEAN → RICH → LEAN → RICH

OK or NG

OK >> GO TO 21.

NG (Monitor does not fluctuate.)>>GO TO 23.

NG (Monitor fluctuates less than 5 times.)>>GO TO 31.

DATA MONITOR	
MONITOR	NO DTC
ENG SPEED	XXX rpm
HO2S1 MNTR (B1)	LEAN
HO2S1 MNTR (B2)	RICH

PBIB0120E

20. CHECK HEATED OXYGEN SENSOR 1 (BANK 1) SIGNAL

Without CONSULT-II

1. Stop engine and set ECM to Self-diagnostic mode II (Heated oxygen sensor 1 monitor). Refer to [EC-70](#), "HOW TO SWITCH DIAGNOSTIC TEST MODE".
2. Start engine and run it at about 2,000 rpm for about 2 minutes under no-load.
3. Running engine at 2,000 rpm under no-load (The engine is warmed up to normal operating temperature.), check that the MIL comes on more than 5 times during 10 seconds.

OK or NG

OK >> GO TO 22.

NG (MIL does not come on)>>GO TO 23.

NG (MIL comes on less than 5 times)>>GO TO 31.

21. CHECK HEATED OXYGEN SENSOR 1 (BANK 2) SIGNAL

With CONSULT-II

1. See "HO2S1 MNTR (B2)" in "DATA MONITOR" mode.
2. Running engine at 2,000 rpm under no-load (The engine is warmed up to normal operating temperature.), check that the monitor fluctuates between LEAN and RICH more than 5 times during 10 seconds.

1 time: RICH → LEAN → RICH

2 times: RICH → LEAN → RICH → LEAN → RICH

OK or NG

OK >> **INSPECTION END**

NG (Monitor does not fluctuate.)>>GO TO 24.

NG (Monitor fluctuates less than 5 times.)>>GO TO 31.

DATA MONITOR	
MONITOR	NO DTC
ENG SPEED	XXX rpm
HO2S1 MNTR (B1)	LEAN
HO2S1 MNTR (B2)	RICH

PBIB0120E

22. CHECK HEATED OXYGEN SENSOR 1 (BANK 2) SIGNAL

⊗ Without CONSULT-II

1. Switch the monitored sensor from bank 1 to bank 2. Refer to [EC-70, "How to Switch Monitored Sensor From Bank 1 to Bank 2 or Vice Versa"](#) .
2. Running engine at 2,000 rpm under no-load (The engine is warmed up to normal operating temperature.), check that the MIL comes on more than 5 times during 10 seconds.

OK or NG

OK >> **INSPECTION END**

NG (MIL does not come on)>>GO TO 24.

NG (MIL comes on less than 5 times)>>GO TO 31.

23. CHECK HEATED OXYGEN SENSOR 1 (BANK 1) HARNESS

1. Turn ignition switch OFF and disconnect battery ground cable.
2. Disconnect ECM harness connector.
3. Disconnect heated oxygen sensor 1 (bank 1) harness connector.
4. Check harness continuity between ECM terminal 35 and heated oxygen sensor 1 (bank 1) terminal 1. Refer to Wiring Diagram, [EC-207, "BANK 1"](#) .

Continuity should exist.

5. Also check harness for short to ground and short to power.

OK or NG

OK >> GO TO 25.

NG >> 1. Repair or replace harness between ECM and heated oxygen sensor 1 (bank 1).

2. GO TO 4.

24. CHECK HEATED OXYGEN SENSOR 1 (BANK 2) HARNESS

1. Turn ignition switch OFF and disconnect battery ground cable.
2. Disconnect ECM harness connector.
3. Disconnect heated oxygen sensor 1 (bank 2) harness connector.
4. Check harness continuity between ECM terminal 16 and heated oxygen sensor 1 (bank 2) terminal 1. Refer to Wiring Diagram, [EC-209, "BANK 2"](#) .

Continuity should exist.

5. Also check harness for short to ground and short to power.

OK or NG

OK >> GO TO 25.

NG >> 1. Repair or replace harness between ECM and heated oxygen sensor 1 (bank 2).

2. GO TO 4.

25. PERFORM ACCELERATOR PEDAL RELEASED POSITION LEARNING

1. Reconnect ECM harness connector.
2. Perform [EC-49, "Accelerator Pedal Released Position Learning"](#) .

>> GO TO 26.

26. PERFORM THROTTLE VALVE CLOSED POSITION LEARNING

Perform [EC-49, "Throttle Valve Closed Position Learning"](#) .

>> GO TO 27.

27. PERFORM IDLE AIR VOLUME LEARNING

Refer to [EC-49, "Idle Air Volume Learning"](#) .

Is Idle Air Volume Learning carried out successfully?

Yes or No

Yes (With CONSULT-II)>>GO TO 28.

Yes (Without CONSULT-II)>>GO TO 29.

No >> 1. Follow the instruction of Idle Air Volume Learning.
2. GO TO 4.

28. CHECK CO%

With CONSULT-II

1. Start engine and warm it up until engine coolant temperature indicator points the middle of gauge.
2. Turn ignition switch OFF, wait at least 10 seconds and then turn ON.
3. Select "ENG COOLANT TEMP" in "ACTIVE TEST" mode.
4. Set "ENG COOLANT TEMP" to 5°C (41°F) by touching "DWN" and "Qd".
5. Start engine and rev it (2,000 to 3,000 rpm) two or three times under no-load, then run engine at idle speed.
6. Check CO%.

Idle CO: 0.7 – 9.9% and engine runs smoothly.

OK or NG

OK >> GO TO 31.

NG >> GO TO 30.

ACTIVE TEST	
ENG COOLANT TEMP	XXX °C
MONITOR	
ENG SPEED	XXX rpm
INJ PULSE-B1	XXX msec
IGN TIMING	XXX BTDC

SEF172Y

29. CHECK CO%

Without CONSULT-II

1. Start engine and warm it up until engine coolant temperature indicator points to the middle of gauge.
2. Turn ignition switch OFF.
3. Disconnect engine coolant temperature sensor harness connector.
4. Connect a resistor (4.4 kΩ) between terminals of engine coolant temperature sensor harness connector.
5. Start engine and rev it (2,000 to 3,000 rpm) two or three times under no-load, then run engine at idle speed.
6. Check CO%.

Idle CO: 0.7 – 9.9% and engine runs smoothly.

7. After checking CO%, turn ignition switch OFF, disconnect the resistor from the terminals of engine coolant temperature sensor harness connector, and then connect engine coolant temperature sensor harness connector to engine coolant temperature sensor.

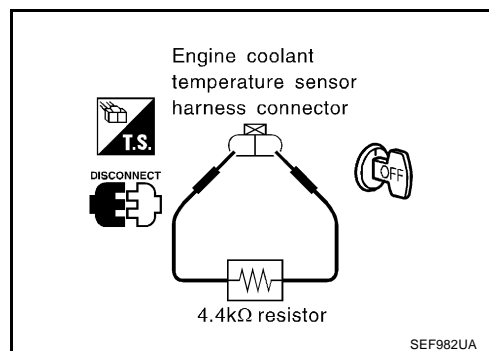

OK or NG

OK >> GO TO 31.

NG >> GO TO 30.

30. RECONNECT HEATED OXYGEN SENSOR 1 HARNESS CONNECTOR

1. Turn ignition switch OFF.
2. Reconnect heated oxygen sensor 1 harness connector.

>> GO TO 34.

31. REPLACE HEATED OXYGEN SENSOR 1

1. Stop engine.
2. Replace heated oxygen sensor 1 on the malfunctioning bank.

With CONSULT-II>>GO TO 32.
Without CONSULT-II>>GO TO 33.

32. CHECK HEATED OXYGEN SENSOR 1 (BANK 1)/(BANK 2) SIGNAL

Ⓟ With CONSULT-II

1. Start engine and warm it up until engine coolant temperature indicator points the middle of gauge.
2. See "HO2S1 MNTR (B1)/(B2)" in "DATA MONITOR" mode.
3. Running engine at 2,000 rpm under no-load (The engine is warmed up to normal operating temperature.), check that the monitor fluctuates between LEAN and RICH more than 5 times during 10 seconds.

1 time: RICH → LEAN → RICH
2 times: RICH → LEAN → RICH → LEAN → RICH

DATA MONITOR	
MONITOR	NO DTC
ENG SPEED	XXX rpm
HO2S1 MNTR (B1)	LEAN
HO2S1 MNTR (B2)	RICH

PBIB0120E

OK or NG

OK >> GO TO 4.
NG >> GO TO 34.

33. CHECK HEATED OXYGEN SENSOR 1 (BANK 1)/(BANK 2) SIGNAL

ⓧ Without CONSULT-II

1. Set ECM to Self-diagnostic mode II (Heated oxygen sensor 1 monitor). Refer to [EC-70, "HOW TO SWITCH DIAGNOSTIC TEST MODE"](#) .
2. Switch the monitored sensor to the malfunctioning bank. Refer to [EC-70, "How to Switch Monitored Sensor From Bank 1 to Bank 2 or Vice Versa"](#) .
3. Running engine at 2,000 rpm under no-load (The engine is warmed up to normal operating temperature.), check that the MIL comes on more than 5 times during 10 seconds.

OK or NG

OK >> GO TO 4.
NG >> GO TO 34.

34. DETECT MALFUNCTIONING PART

Check the following.

- Check fuel pressure regulator and repair or replace if necessary. Refer to [EC-51, "Fuel Pressure Check"](#) .
- Check mass air flow sensor and its circuit, and repair or replace if necessary. Refer to [EC-165](#) and [EC-173](#) .
- Check injector and its circuit, and repair or replace if necessary. Refer to [EC-597](#) .
- Check engine coolant temperature sensor and its circuit, and repair or replace if necessary. Refer to [EC-185](#) and [EC-197](#) .

OK or NG

OK >> GO TO 36.
NG >> 1. Repair or replace.
2. GO TO 35.

35. ERASE UNNECESSARY DTC

After this inspection, unnecessary DTC might be displayed.
Erase the stored memory in ECM and TCM. Refer to [EC-67, "HOW TO ERASE EMISSION-RELATED DIAGNOSTIC INFORMATION"](#) and [AT-39, "HOW TO ERASE DTC"](#) .

>> GO TO 4.

36. CHECK ECM FUNCTION

1. Substitute another known-good ECM to check ECM function. (ECM may be the cause of an incident, but this is a rare case.)
2. Perform initialization of IVIS (NATS) system and registration of IVIS (NATS) ignition key IDs. Refer to [BL-208, "ECM Re-communicating Function"](#) .

>> GO TO 4.

Accelerator Pedal Released Position Learning

ABS006KE

DESCRIPTION

Accelerator Pedal Released Position Learning is an operation to learn the fully released position of the accelerator pedal by monitoring the accelerator pedal position sensor output signal. It must be performed each time harness connector of accelerator pedal position sensor or ECM is disconnected.

OPERATION PROCEDURE

1. Make sure that accelerator pedal is fully released.
2. Turn ignition switch ON and wait at least 2 seconds.
3. Turn ignition switch OFF wait at least 10 seconds.
4. Turn ignition switch ON and wait at least 2 seconds.
5. Turn ignition switch OFF wait at least 10 seconds.

Throttle Valve Closed Position Learning

ABS006KF

DESCRIPTION

Throttle Valve Closed Position Learning is an operation to learn the fully closed position of the throttle valve by monitoring the throttle position sensor output signal. It must be performed each time harness connector of electric throttle control actuator or ECM is disconnected.

OPERATION PROCEDURE

1. Make sure that accelerator pedal is fully released.
2. Turn ignition switch ON.
3. Turn ignition switch OFF wait at least 10 seconds.
Make sure that throttle valve moves during above 10 seconds by confirming the operating sound.

Idle Air Volume Learning

ABS006KG

DESCRIPTION

Idle Air Volume Learning is an operation to learn the idle air volume that keeps each engine within the specific range. It must be performed under any of the following conditions:

- Each time electric throttle control actuator or ECM is replaced.
- Idle speed or ignition timing is out of specification.

PREPARATION

Before performing Idle Air Volume Learning, make sure that all of the following conditions are satisfied. Learning will be cancelled if any of the following conditions are missed for even a moment.

- Battery voltage: More than 12.9V (At idle)
- Engine coolant temperature: 70 - 100°C (158 - 212°F)
- PNP switch: ON
- Electric load switch: OFF
(Air conditioner, headlamp, rear window defogger)

On vehicles equipped with daytime light systems, if the parking brake is applied before the engine is started the headlamp will not be illuminated.

- Steering wheel: Neutral (Straight-ahead position)
- Vehicle speed: Stopped
- Transmission: Warmed-up
For models with CONSULT-II, drive vehicle until "FLUID TEMP SE" in "DATA MONITOR" mode of "A/T" system indicates less than 0.9V.
For models without CONSULT-II, drive vehicle for 10 minutes.

OPERATION PROCEDURE

④ With CONSULT-II

1. Perform [EC-49, "Accelerator Pedal Released Position Learning"](#) .
2. Perform [EC-49, "Throttle Valve Closed Position Learning"](#) .
3. Start engine and warm it up to normal operating temperature.
4. Check that all items listed under the topic PREPARATION (previously mentioned) are in good order.
5. Select "IDLE AIR VOL LEARN" in "WORK SUPPORT" mode.

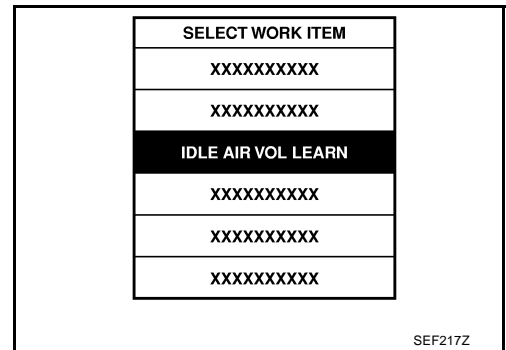

6. Touch "START" and wait 20 seconds.

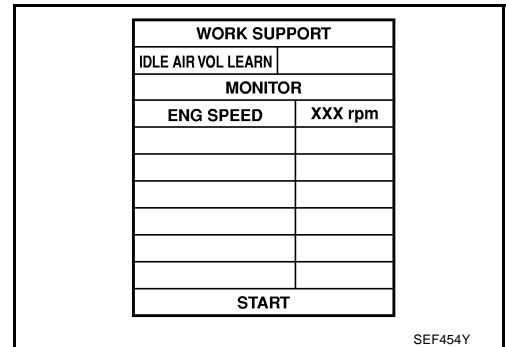

7. Make sure that "CMPLT" is displayed on CONSULT-II screen. If "CMPLT" is not displayed, Idle Air Volume Learning will not be carried out successfully. In this case, find the cause of the incident by referring to the Diagnostic Procedure below.
8. Rev up the engine two or three times and make sure that idle speed and ignition timing are within the specifications.

ITEM	SPECIFICATION
Idle speed	650±50 rpm (in P or N position)
Ignition timing	15±5° BTDC (in P or N position)

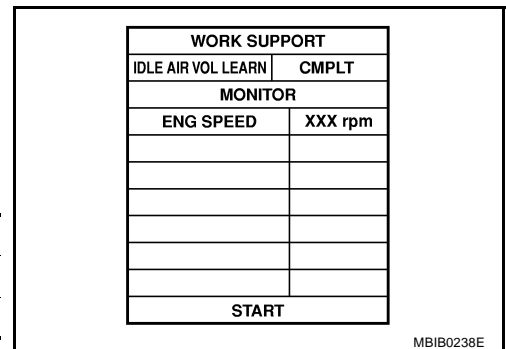

⊗ Without CONSULT-II

NOTE:

- It is better to count the time accurately with a clock.
 - It is impossible to switch the diagnostic mode when an accelerator pedal position sensor circuit has a malfunction.
1. Perform [EC-49, "Accelerator Pedal Released Position Learning"](#) .

2. Perform [EC-49, "Throttle Valve Closed Position Learning"](#) .
3. Start engine and warm it up to normal operating temperature.
4. Check that all items listed under the topic PREPARATION (previously mentioned) are in good order.
5. Turn ignition switch OFF and wait at least 10 seconds.
6. Confirm that accelerator pedal is fully released, then turn ignition switch ON and wait 3 seconds.
7. Repeat the following procedure quickly five times within 5 seconds.
 - a. Fully depress the accelerator pedal.
 - b. Fully release the accelerator pedal.
8. Wait 7 seconds, fully depress the accelerator pedal and keep it for approx. 20 seconds until the MIL stops blinking and turned ON.
9. Fully release the accelerator pedal within 3 seconds after the MIL turned ON.
10. Start engine and let it idle.
11. Wait 20 seconds.

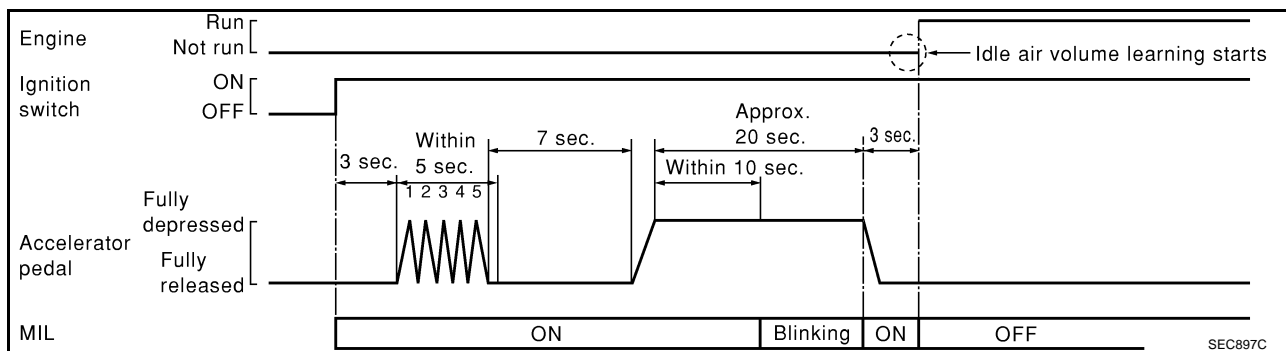

12. Rev up the engine two or three times and make sure that idle speed and ignition timing are within the specifications.

ITEM	SPECIFICATION
Idle speed	650±50 rpm (in P or N position)
Ignition timing	15±5° BTDC (in P or N position)

13. If idle speed and ignition timing are not within the specification, Idle Air Volume Learning will not be carried out successfully. In this case, find the cause of the incident by referring to the DIAGNOSTIC PROCEDURE below.

DIAGNOSTIC PROCEDURE

If idle air volume learning cannot be performed successfully, proceed as follows:

1. Check that throttle valve is fully closed.
2. Check PCV valve operation.
3. Check that downstream of throttle valve is free from air leakage.
4. When the above three items check out OK, engine component parts and their installation condition are questionable. Check and eliminate the cause of the incident.
It is useful to perform [EC-131, "TROUBLE DIAGNOSIS - SPECIFICATION VALUE"](#) .
5. If any of the following conditions occur after the engine has started, eliminate the cause of the incident and perform Idle air volume learning all over again:
 - Engine stalls.
 - Erroneous idle.

Fuel Pressure Check FUEL PRESSURE RELEASE

ABS006KH

Ⓜ With CONSULT-II

1. Turn ignition switch ON.

2. Perform "FUEL PRESSURE RELEASE" in "WORK SUPPORT" mode with CONSULT-II.
3. Start engine.
4. After engine stalls, crank it two or three times to release all fuel pressure.
5. Turn ignition switch OFF.

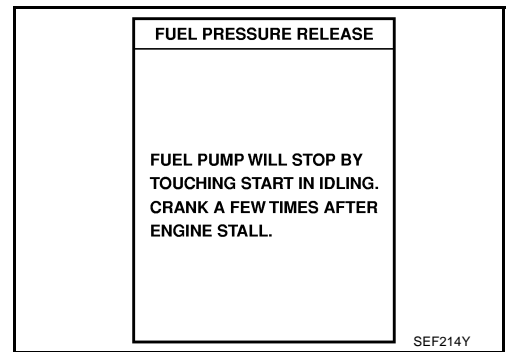

⊗ **Without CONSULT-II**

1. Remove fuel pump fuse located in IPDM E/R.
2. Start engine.
3. After engine stalls, crank it two or three times to release all fuel pressure.
4. Turn ignition switch OFF.
5. Reinstall fuel pump fuse after servicing fuel system.

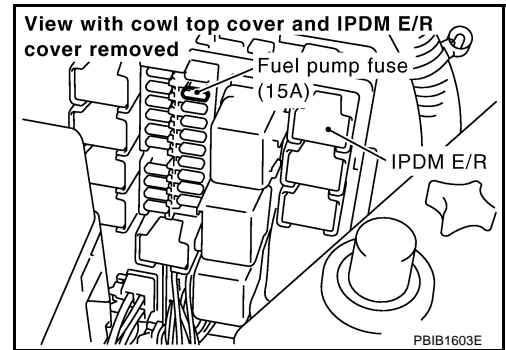

FUEL PRESSURE CHECK

Before disconnecting fuel line, release fuel pressure from fuel line to eliminate danger.

NOTE:

Prepare pans or saucers under the disconnected fuel line because the fuel may spill out. The fuel pressure cannot be completely released because S50 models do not have fuel return system.

Use Fuel Pressure Gauge Kit (J-44321) to check fuel pressure.

1. Release fuel pressure to zero. Refer to [EC-51, "FUEL PRESSURE RELEASE"](#).
2. Install the inline fuel quick disconnected fitting between fuel damper and injector tube.
3. Connect the fuel pressure test gauge (quick connector adapter hose) to the inline fuel quick disconnected fitting.
4. Turn ignition switch ON and check for fuel leakage.
5. Start engine and check for fuel leakage.
6. Read the indication of fuel pressure gauge.

At idling: Approximately 350 kPa (3.57 kg/cm² , 51 psi)

7. If result is unsatisfactory, go to next step.
8. Check the following.
 - Fuel hoses and fuel tubes for clogging
 - Fuel filter for clogging
 - Fuel pump
 - Fuel pressure regulator for clogging
 If OK, replace fuel pressure regulator.
 If NG, repair or replace.

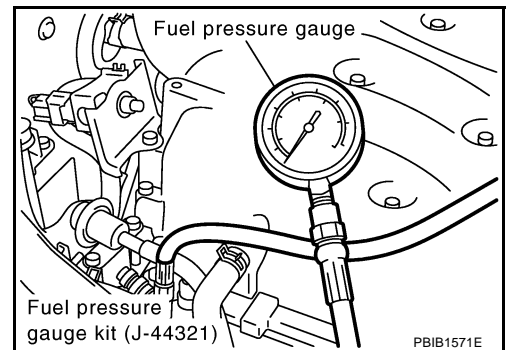

ON BOARD DIAGNOSTIC (OBD) SYSTEM

PFP:00028

Introduction

ABS006KI

The ECM has an on board diagnostic system, which detects malfunctions related to engine sensors or actuators. The ECM also records various emission-related diagnostic information including:

Emission-related diagnostic information	SAE Mode
Diagnostic Trouble Code (DTC)	Mode 3 of SAE J1979
Freeze Frame data	Mode 2 of SAE J1979
System Readiness Test (SRT) code	Mode 1 of SAE J1979
1st Trip Diagnostic Trouble Code (1st Trip DTC)	Mode 7 of SAE J1979
1st Trip Freeze Frame data	
Test values and Test limits	Mode 6 of SAE J1979
Calibration ID	Mode 9 of SAE J1979

The above information can be checked using procedures listed in the table below.

×: Applicable —: Not applicable

	DTC	1st trip DTC	Freeze Frame data	1st trip Freeze Frame data	SRT code	Test value
CONSULT-II	×	×	×	×	×	—
GST	×	×	×	—	×	×
ECM	×	×*	—	—	—	—

*: When DTC and 1st trip DTC simultaneously appear on the display, they cannot be clearly distinguished from each other.

The malfunction indicator lamp (MIL) on the instrument panel lights up when the same malfunction is detected in two consecutive trips (Two trip detection logic), or when the ECM enters fail-safe mode. (Refer to [EC-82](#).)

Two Trip Detection Logic

ABS006KJ

When a malfunction is detected for the first time, 1st trip DTC and 1st trip Freeze Frame data are stored in the ECM memory. The MIL will not light up at this stage. <1st trip>

If the same malfunction is detected again during the next drive, the DTC and Freeze Frame data are stored in the ECM memory, and the MIL lights up. The MIL lights up at the same time when the DTC is stored. <2nd trip> The “trip” in the “Two Trip Detection Logic” means a driving mode in which self-diagnosis is performed during vehicle operation. Specific on board diagnostic items will cause the ECM to light up or blink the MIL, and store DTC and Freeze Frame data, even in the 1st trip, as shown below.

×: Applicable —: Not applicable

Items	MIL				DTC		1st trip DTC	
	1st trip		2nd trip		1st trip displaying	2nd trip displaying	1st trip displaying	2nd trip displaying
	Blinking	Lighting up	Blinking	Lighting up				
Misfire (Possible three way catalyst damage) — DTC: P0300 - P0306 is being detected	×	—	—	—	—	—	×	—
Misfire (Possible three way catalyst damage) — DTC: P0300 - P0306 is being detected	—	—	×	—	—	×	—	—
One trip detection diagnoses (Refer to EC-15 .)	—	×	—	—	×	—	—	—
Except above	—	—	—	×	—	×	×	—

When there is an open circuit on MIL circuit, the ECM cannot warn the driver by lighting MIL up when there is malfunction on engine control system.

Therefore, when electrical controlled throttle and part of ECM related diagnoses are continuously detected as NG for 5 trips, ECM warns the driver that engine control system malfunctions and MIL circuit is open by means of operating fail-safe function.

ON BOARD DIAGNOSTIC (OBD) SYSTEM

[VQ35DE]

The fail-safe function also operates when above diagnoses except MIL circuit are detected and demands the driver to repair the malfunction.

Engine operating condition in fail-safe mode

Engine speed will not rise more than 2,500 rpm due to the fuel cut

Emission-Related Diagnostic Information EMISSION-RELATED DIAGNOSTIC INFORMATION ITEMS

ABS006KK

Items (CONSULT-II screen terms)	DTC*1		SRT code	Test value/ Test limit (GST only)	1st trip DTC	Reference page
	CONSULT-II GST*2	ECM*3				
CAN COMM CIRCUIT	U1000	1000*6	—	—	—	EC-142
CAN COMM CIRCUIT	U1001	1001*6	—	—	×	EC-142
NO DTC IS DETECTED. FURTHER TESTING MAY BE REQUIRED.	P0000	0000	—	—	—	—
INT/V TIM CONT-B1	P0011	0011	—	—	×	EC-145
INT/V TIM CONT-B2	P0021	0021	—	—	×	EC-145
HO2S1 HTR (B1)	P0031	0031	×	×	×*5	EC-149
HO2S1 HTR (B1)	P0032	0032	×	×	×*5	EC-149
HO2S2 HTR (B1)	P0037	0037	×	×	×*5	EC-157
HO2S2 HTR (B1)	P0038	0038	×	×	×*5	EC-157
HO2S1 HTR (B2)	P0051	0051	×	×	×*5	EC-149
HO2S1 HTR (B2)	P0052	0052	×	×	×*5	EC-149
HO2S2 HTR (B2)	P0057	0057	×	×	×*5	EC-157
HO2S2 HTR (B2)	P0058	0058	×	×	×*5	EC-157
MAF SEN/CIRCUIT	P0101	0101	—	—	—	EC-165
MAF SEN/CIRCUIT	P0102	0102	—	—	—	EC-173
MAF SEN/CIRCUIT	P0103	0103	—	—	—	EC-173
IAT SEN/CIRCUIT	P0112	0112	—	—	×	EC-180
IAT SEN/CIRCUIT	P0113	0113	—	—	×	EC-180
ECT SEN/CIRCUIT	P0117	0117	—	—	—	EC-185
ECT SEN/CIRCUIT	P0118	0118	—	—	—	EC-185
TP SEN 2/CIRC	P0122	0122	—	—	—	EC-190
TP SEN 2/CIRC	P0123	0123	—	—	—	EC-190
ECT SENSOR	P0125	0125	—	—	—	EC-197
IAT SENSOR	P0127	0127	—	—	×	EC-200
THERMSTAT FNCTN	P0128	0128	—	—	×	EC-203
HO2S1 (B1)	P0132	0132	—	×	×	EC-205
HO2S1 (B1)	P0133	0133	×	×	×*5	EC-214
HO2S1 (B1)	P0134	0134	—	×	×	EC-226
HO2S2 (B1)	P0138	0138	—	×	×	EC-236
HO2S2 (B1)	P0139	0139	×	×	×*5	EC-245
HO2S1 (B2)	P0152	0152	—	×	×	EC-205
HO2S1 (B2)	P0153	0153	×	×	×*5	EC-214
HO2S1 (B2)	P0154	0154	—	×	×	EC-226
HO2S2 (B2)	P0158	0158	—	×	×	EC-236

ON BOARD DIAGNOSTIC (OBD) SYSTEM

[VQ35DE]

Items (CONSULT-II screen terms)	DTC*1		SRT code	Test value/ Test limit (GST only)	1st trip DTC	Reference page
	CONSULT-II GST*2	ECM*3				
HO2S2 (B2)	P0159	0159	×	×	×*5	EC-245
FUEL SYS-LEAN-B1	P0171	0171	—	—	×	EC-256
FUEL SYS-RICH-B1	P0172	0172	—	—	×	EC-265
FUEL SYS-LEAN-B2	P0174	0174	—	—	×	EC-256
FUEL SYS-RICH-B2	P0175	0175	—	—	×	EC-265
FTT SENSOR	P0181	0181	—	—	×	EC-273
FTT SEN/CIRCUIT	P0182	0182	—	—	×	EC-279
FTT SEN/CIRCUIT	P0183	0183	—	—	×	EC-279
TP SEN 1/CIRC	P0222	0222	—	—	—	EC-284
TP SEN 1/CIRC	P0223	0223	—	—	—	EC-284
MULTI CYL MISFIRE	P0300	0300	—	—	×	EC-291
CYL 1 MISFIRE	P0301	0301	—	—	×	EC-291
CYL 2 MISFIRE	P0302	0302	—	—	×	EC-291
CYL 3 MISFIRE	P0303	0303	—	—	×	EC-291
CYL 4 MISFIRE	P0304	0304	—	—	×	EC-291
CYL 5 MISFIRE	P0305	0305	—	—	×	EC-291
CYL 6 MISFIRE	P0306	0306	—	—	×	EC-291
KNOCK SEN/CIRC-B1	P0327	0327	—	—	×	EC-297
KNOCK SEN/CIRC-B1	P0328	0328	—	—	×	EC-297
CKP SEN/CIRCUIT	P0335	0335	—	—	×	EC-302
CMP SEN/CIRC-B1	P0340	0340	—	—	×	EC-308
CMP SEN/CIRC-B2	P0345	0345	—	—	×	EC-308
TW CATALYST SYS-B1	P0420	0420	×	×	×*5	EC-316
TW CATALYST SYS-B2	P0430	0430	×	×	×*5	EC-316
EVAP PURG FLOW/MON	P0441	0441	×	×	×*5	EC-321
EVAP SMALL LEAK	P0442	0442	×	×	×*5	EC-326
PURG VOLUME CONT/V	P0444	0444	—	—	×	EC-335
PURG VOLUME CONT/V	P0445	0445	—	—	×	EC-335
VENT CONTROL VALVE	P0447	0447	—	—	×	EC-342
EVAP SYS PRES SEN	P0451	0451	—	—	×	EC-349
EVAP SYS PRES SEN	P0452	0452	—	—	×	EC-352
EVAP SYS PRES SEN	P0453	0453	—	—	×	EC-358
EVAP GROSS LEAK	P0455	0455	—	×	×*5	EC-366
EVAP VERY SML LEAK	P0456	0456	×*4	×	×	EC-374
FUEL LEV SEN SLOSH	P0460	0460	—	—	×	EC-384
FUEL LEVEL SENSOR	P0461	0461	—	—	×	EC-386
FUEL LEVL SEN/CIRC	P0462	0462	—	—	×	EC-388
FUEL LEVEL SEN/CIRC	P0463	0463	—	—	×	EC-388
VEH SPEED SEN/CIRC*7	P0500	0500	—	—	×	EC-390
ISC SYSTEM	P0506	0506	—	—	×	EC-392
ISC SYSTEM	P0507	0507	—	—	×	EC-394

ON BOARD DIAGNOSTIC (OBD) SYSTEM

[VQ35DE]

Items (CONSULT-II screen terms)	DTC*1		SRT code	Test value/ Test limit (GST only)	1st trip DTC	Reference page
	CONSULT-II GST*2	ECM*3				
PW ST P SEN/CIRC	P0550	0550	—	—	×	EC-396
ECM	P0605	0605	—	—	× or —	EC-401
PNP SW/CIRC	P0705	0705	—	—	×	AT-112
ATF TEMP SEN/CIRC	P0710	0710	—	—	×	AT-139
VEH SPD SEN/CIR AT*7	P0720	0720	—	—	×	AT-116
ENGINE SPEED SIG	P0725	0725	—	—	×	AT-121
TCC SOLENOID/CIRC	P0740	0740	—	—	×	AT-123
A/T TCC S/V FNCTN	P0744	0744	—	—	×	AT-125
L/PRESS SOL/CIRC	P0745	0745	—	—	×	AT-127
ECM BACK UP/CIRC	P1065	1065	—	—	×	EC-404
INT/V TIM V/CIR-B1	P1111	1111	—	—	×	EC-408
ETC ACTR	P1121	1121	—	—	—	EC-415
ETC FUNCTION/CIRC	P1122	1122	—	—	—	EC-417
ETC MOT PWR	P1124	1124	—	—	—	EC-423
ETC MOT PWR	P1126	1126	—	—	—	EC-423
ETC MOT	P1128	1128	—	—	—	EC-428
INT/V TIM V/CIR-B2	P1136	1136	—	—	×	EC-408
HO2S1 (B1)	P1143	1143	×	×	×*5	EC-433
HO2S1 (B1)	P1144	1144	×	×	×*5	EC-439
HO2S2 (B1)	P1146	1146	×	×	×*5	EC-446
HO2S2 (B1)	P1147	1147	×	×	×*5	EC-457
CLOSED LOOP-B1	P1148	1148	—	—	—	EC-468
HO2S1 (B2)	P1163	1163	×	×	×*5	EC-433
HO2S1 (B2)	P1164	1164	×	×	×*5	EC-439
HO2S2 (B2)	P1166	1166	×	×	×*5	EC-446
HO2S2 (B2)	P1167	1167	×	×	×*5	EC-457
CLOSED LOOP-B2	P1168	1168	—	—	—	EC-468
TCS C/U FUNCTN	P1211	1211	—	—	×	EC-470
TCS/CIRC	P1212	1212	—	—	×	EC-471
ENG OVER TEMP	P1217	1217	—	—	—	EC-472
CTP LEARNING	P1225	1225	—	—	×	EC-485
CTP LEARNING	P1226	1226	—	—	×	EC-487
SENSOR POWER/CIRC	P1229	1229	—	—	—	EC-489
PURG VOLUME CONT/V	P1444	1444	—	—	×	EC-494
VENT CONTROL VALVE	P1446	1446	—	—	×	EC-502
ASCD SW*8	P1564	1564	—	—	—	EC-515, EC-508
ACC COMMAND VALUE*9	P1568	1568	—	—	—	EC-521
ASCD BRAKE SW*8	P1572	1572	—	—	—	EC-532, EC-522
ASCD VHL SPD SEN*8	P1574	1574	—	—	—	EC-543, EC-541

ON BOARD DIAGNOSTIC (OBD) SYSTEM

[VQ35DE]

Items (CONSULT-II screen terms)	DTC*1		SRT code	Test value/ Test limit (GST only)	1st trip DTC	Reference page
	CONSULT-II GST*2	ECM*3				
NATS MALFUNCTION	P1610 - P1615	1610 - 1615	—	—	×	EC-68
TP SEN/CIRC A/T	P1705	1705	—	—	—	AT-136
P-N POS SW/CIRCUIT	P1706	1706	—	—	×	EC-545
TURBINE REV S/CIRC	P1716	1716	—	—	×	AT-143
A/T INTERLOCK	P1730	1730	—	—	—	AT-147
I/C SOLENOID/CIRC	P1752	1752	—	—	—	AT-152
I/C SOLENOID FNCTN	P1754	1754	—	—	—	AT-154
FR/B SOLENOID/CIRC	P1757	1757	—	—	—	AT-156
FR/B SOLENOID/CIRC	P1759	1759	—	—	—	AT-158
D/C SOLENOID/CIRC	P1762	1762	—	—	—	AT-160
D/C SOLENOID FNCTN	P1764	1764	—	—	—	AT-162
HLR/C SOL/CIRC	P1767	1767	—	—	—	AT-164
HLR/C SOL FNCTN	P1769	1769	—	—	—	AT-166
LC/B SOLENOID/CIRC	P1772	1772	—	—	—	AT-168
LC/B SOLENOID FNCT	P1774	1774	—	—	—	AT-170
BRAKE SW/CIRCUIT	P1805	1805	—	—	×	EC-550
APP SEN 1/CIRC	P2122	2122	—	—	—	EC-555
APP SEN 1/CIRC	P2123	2123	—	—	—	EC-555
APP SEN 2/CIRC	P2127	2127	—	—	—	EC-562
APP SEN 2/CIRC	P2128	2128	—	—	—	EC-562
TP SENSOR	P2135	2135	—	—	—	EC-569
APP SENSOR	P2138	2138	—	—	—	EC-576

*1: 1st trip DTC No. is the same as DTC No.

*2: This number is prescribed by SAE J2012.

*3: In Diagnostic Test Mode II (Self-diagnostic results), this number is controlled by NISSAN.

*4: SRT code will not be set if the self-diagnostic result is NG.

*5: This is not displayed with GST.

*6: The troubleshooting for this DTC needs CONSULT-II.

*7: When the fail-safe operations for both self-diagnoses occur at the same time, the MIL illuminates.

*8: For models with ICC or ASCD system.

*9: For models with ICC system.

DTC AND 1ST TRIP DTC

The 1st trip DTC (whose number is the same as the DTC number) is displayed for the latest self-diagnostic result obtained. If the ECM memory was cleared previously, and the 1st trip DTC did not reoccur, the 1st trip DTC will not be displayed.

If a malfunction is detected during the 1st trip, the 1st trip DTC is stored in the ECM memory. The MIL will not light up (two trip detection logic). If the same malfunction is not detected in the 2nd trip (meeting the required driving pattern), the 1st trip DTC is cleared from the ECM memory. If the same malfunction is detected in the 2nd trip, both the 1st trip DTC and DTC are stored in the ECM memory and the MIL lights up. In other words, the DTC is stored in the ECM memory and the MIL lights up when the same malfunction occurs in two consecutive trips. If a 1st trip DTC is stored and a non-diagnostic operation is performed between the 1st and 2nd trips, only the 1st trip DTC will continue to be stored. For malfunctions that blink or light up the MIL during the 1st trip, the DTC and 1st trip DTC are stored in the ECM memory.

Procedures for clearing the DTC and the 1st trip DTC from the ECM memory are described in [EC-67, "HOW TO ERASE EMISSION-RELATED DIAGNOSTIC INFORMATION"](#).

For malfunctions in which 1st trip DTCs are displayed, refer to [EC-54, "EMISSION-RELATED DIAGNOSTIC INFORMATION ITEMS"](#). These items are required by legal regulations to continuously monitor the system/component. In addition, the items monitored non-continuously are also displayed on CONSULT-II.

1st trip DTC is specified in Mode 7 of SAE J1979. 1st trip DTC detection occurs without lighting up the MIL and therefore does not warn the driver of a malfunction. However, 1st trip DTC detection will not prevent the vehicle from being tested, for example during Inspection/Maintenance (I/M) tests.

When a 1st trip DTC is detected, check, print out or write down and erase (1st trip) DTC and Freeze Frame data as specified in Work Flow procedure Step II, refer to [EC-78, "WORK FLOW"](#) . Then perform DTC Confirmation Procedure or Overall Function Check to try to duplicate the malfunction. If the malfunction is duplicated, the item requires repair.

How to Read DTC and 1st Trip DTC

DTC and 1st trip DTC can be read by the following methods.

 **With CONSULT-II**

 **With GST**

CONSULT-II or GST (Generic Scan Tool) Examples: P0340, P1148, P1706, etc.

These DTCs are prescribed by SAE J2012.

(CONSULT-II also displays the malfunctioning component or system.)

 **No Tools**

The number of blinks of the MIL in the Diagnostic Test Mode II (Self-Diagnostic Results) indicates the DTC. Example: 0340, 1148, 1706, etc.

These DTCs are controlled by NISSAN.

- **1st trip DTC No. is the same as DTC No.**
- **Output of a DTC indicates a malfunction. However, GST or the Diagnostic Test Mode II do not indicate whether the malfunction is still occurring or has occurred in the past and has returned to normal. CONSULT-II can identify malfunction status as shown below. Therefore, using CONSULT-II (if available) is recommended.**

A sample of CONSULT-II display for DTC and 1st trip DTC is shown below. DTC or 1st trip DTC of a malfunction is displayed in SELF-DIAGNOSTIC RESULTS mode of CONSULT-II. Time data indicates how many times the vehicle was driven after the last detection of a DTC.

If the DTC is being detected currently, the time data will be [0].

If a 1st trip DTC is stored in the ECM, the time data will be [1t].

DTC display	SELF DIAG RESULTS		1st trip DTC display	SELF DIAG RESULTS	
	DTC RESULTS			DTC RESULTS	
	CKP SEN/CIRCUIT [P0335]	0		CKP SEN/CIRCUIT [P0335]	1t

PBIB0911E

FREEZE FRAME DATA AND 1ST TRIP FREEZE FRAME DATA

The ECM records the driving conditions such as fuel system status, calculated load value, engine coolant temperature, short term fuel trim, long term fuel trim, engine speed, vehicle speed, base fuel schedule and intake air temperature at the moment a malfunction is detected.

Data which are stored in the ECM memory, along with the 1st trip DTC, are called 1st trip freeze frame data. The data, stored together with the DTC data, are called freeze frame data and displayed on CONSULT-II or GST. The 1st trip freeze frame data can only be displayed on the CONSULT-II screen, not on the GST. For details, see [EC-113, "Freeze Frame Data and 1st Trip Freeze Frame Data"](#) .

Only one set of freeze frame data (either 1st trip freeze frame data or freeze frame data) can be stored in the ECM. 1st trip freeze frame data is stored in the ECM memory along with the 1st trip DTC. There is no priority for 1st trip freeze frame data and it is updated each time a different 1st trip DTC is detected. However, once freeze frame data (2nd trip detection/MIL on) is stored in the ECM memory, 1st trip freeze frame data is no longer stored. Remember, only one set of freeze frame data can be stored in the ECM. The ECM has the following priorities to update the data.

ON BOARD DIAGNOSTIC (OBD) SYSTEM

[VQ35DE]

Priority	Items	
1	Freeze frame data	Misfire — DTC: P0300 - P0306 Fuel Injection System Function — DTC: P0171, P0172, P0174, P0175
2		Except the above items (Includes A/T related items)
3	1st trip freeze frame data	

For example, the EGR malfunction (Priority: 2) was detected and the freeze frame data was stored in the 2nd trip. After that when the misfire (Priority: 1) is detected in another trip, the freeze frame data will be updated from the EGR malfunction to the misfire. The 1st trip freeze frame data is updated each time a different malfunction is detected. There is no priority for 1st trip freeze frame data. However, once freeze frame data is stored in the ECM memory, 1st trip freeze data is no longer stored (because only one freeze frame data or 1st trip freeze frame data can be stored in the ECM). If freeze frame data is stored in the ECM memory and freeze frame data with the same priority occurs later, the first (original) freeze frame data remains unchanged in the ECM memory.

Both 1st trip freeze frame data and freeze frame data (along with the DTCs) are cleared when the ECM memory is erased. Procedures for clearing the ECM memory are described in [EC-67, "HOW TO ERASE EMIS-SION-RELATED DIAGNOSTIC INFORMATION"](#).

SYSTEM READINESS TEST (SRT) CODE

System Readiness Test (SRT) code is specified in Mode 1 of SAE J1979.

As part of an enhanced emissions test for Inspection & Maintenance (I/M), certain states require the status of SRT be used to indicate whether the ECM has completed self-diagnosis of major emission systems and components. Completion must be verified in order for the emissions inspection to proceed.

If a vehicle is rejected for a State emissions inspection due to one or more SRT items indicating "INCMP", use the information in this Service Manual to set the SRT to "CMPLT".

In most cases the ECM will automatically complete its self-diagnosis cycle during normal usage, and the SRT status will indicate "CMPLT" for each application system. Once set as "CMPLT", the SRT status remains "CMPLT" until the self-diagnosis memory is erased.

Occasionally, certain portions of the self-diagnostic test may not be completed as a result of the customer's normal driving pattern; the SRT will indicate "INCMP" for these items.

NOTE:

The SRT will also indicate "INCMP" if the self-diagnosis memory is erased for any reason or if the ECM memory power supply is interrupted for several hours.

If, during the state emissions inspection, the SRT indicates "CMPLT" for all test items, the inspector will continue with the emissions test. However, if the SRT indicates "INCMP" for one or more of the SRT items the vehicle is returned to the customer untested.

NOTE:

If MIL is ON during the state emissions inspection, the vehicle is also returned to the customer untested even though the SRT indicates "CMPLT" for all test items. Therefore, it is important to check SRT ("CMPLT") and DTC (No DTCs) before the inspection.

ON BOARD DIAGNOSTIC (OBD) SYSTEM

[VQ35DE]

SRT Item

The table below shows required self-diagnostic items to set the SRT to "CMPLT".

SRT item (CONSULT-II indication)	Performance Priority*1	Required self-diagnostic items to set the SRT to "CMPLT"	Corresponding DTC No.
CATALYST	2	Three way catalyst function	P0420, P0430
EVAP SYSTEM	1	EVAP control system	P0442
	2	EVAP control system	P0456
	2	EVAP control system purge flow monitoring	P0441
HO2S	2	Heated oxygen sensor 1	P0133, P0153
		Heated oxygen sensor 1	P1143, P1163
		Heated oxygen sensor 1	P1144, P1164
		Heated oxygen sensor 2	P0139, P0159
		Heated oxygen sensor 2	P1146, P1166
		Heated oxygen sensor 2	P1147, P1167
HO2S HTR	2	Heated oxygen sensor 1 heater	P0031, P0032, P0051, P0052
		Heated oxygen sensor 2 heater	P0037, P0038, P0057, P0058

*1: If completion of several SRTs is required, perform driving patterns (DTC confirmation procedure), one by one based on the priority for models with CONSULT-II.

SRT Set Timing

SRT is set as "CMPLT" after self-diagnosis has been performed one or more times. Completion of SRT is done regardless of whether the result is OK or NG. The set timing is different between OK and NG results and is shown in the table below.

Self-diagnosis result		Example						
		Diagnosis	Ignition cycle					
			← ON →	OFF	← ON →	OFF	← ON →	OFF
All OK	Case 1	P0400	OK (1)	— (1)	OK (2)	— (2)	— (2)	OK (2)
		P0402	OK (1)	— (1)	— (1)	— (1)	OK (2)	OK (2)
		P1402	OK (1)	OK (2)	— (2)	— (2)	— (2)	— (2)
		SRT of EGR	"CMPLT"	"CMPLT"	"CMPLT"	"CMPLT"	"CMPLT"	"CMPLT"
	Case 2	P0400	OK (1)	— (1)	— (1)	— (1)	— (1)	— (1)
		P0402	— (0)	— (0)	OK (1)	— (1)	— (1)	— (1)
		P1402	OK (1)	OK (2)	— (2)	— (2)	— (2)	— (2)
		SRT of EGR	"INCMP"	"INCMP"	"CMPLT"	"CMPLT"	"CMPLT"	"CMPLT"
NG exists	Case 3	P0400	OK	OK	—	—	—	
		P0402	—	—	—	—	—	
		P1402	NG	—	NG	NG	NG (Consecutive NG)	
		(1st trip) DTC	1st trip DTC	—	1st trip DTC	DTC (= MIL ON)		
		SRT of EGR	"INCMP"	"INCMP"	"INCMP"	"CMPLT"	"CMPLT"	

OK: Self-diagnosis is carried out and the result is OK.

NG: Self-diagnosis is carried out and the result is NG.

—: Self-diagnosis is not carried out.

When all SRT related self-diagnoses showed OK results in a single cycle (Ignition OFF-ON-OFF), the SRT will indicate "CMPLT". → Case 1 above

ON BOARD DIAGNOSTIC (OBD) SYSTEM

[VQ35DE]

When all SRT related self-diagnoses showed OK results through several different cycles, the SRT will indicate "CMPLT" at the time the respective self-diagnoses have at least one OK result. → Case 2 above
If one or more SRT related self-diagnoses showed NG results in 2 consecutive cycles, the SRT will also indicate "CMPLT". → Case 3 above

The table above shows that the minimum number of cycles for setting SRT as "INCMP" is one (1) for each self-diagnosis (Case 1 & 2) or two (2) for one of self-diagnoses (Case 3). However, in preparation for the state emissions inspection, it is unnecessary for each self-diagnosis to be executed twice (Case 3) for the following reasons:

- The SRT will indicate "CMPLT" at the time the respective self-diagnoses have one (1) OK result.
- The emissions inspection requires "CMPLT" of the SRT only with OK self-diagnosis results.
- When, during SRT driving pattern, 1st trip DTC (NG) is detected prior to "CMPLT" of SRT, the self-diagnosis memory must be erased from ECM after repair.
- If the 1st trip DTC is erased, all the SRT will indicate "INCMP".

NOTE:

SRT can be set as "CMPLT" together with the DTC(s). Therefore, DTC check must always be carried out prior to the state emission inspection even though the SRT indicates "CMPLT".

SRT Service Procedure

If a vehicle has failed the state emissions inspection due to one or more SRT items indicating "INCMP", review the flowchart diagnostic sequence on the next page.

A
EC
C
D
E
F
G
H
I
J
K
L
M

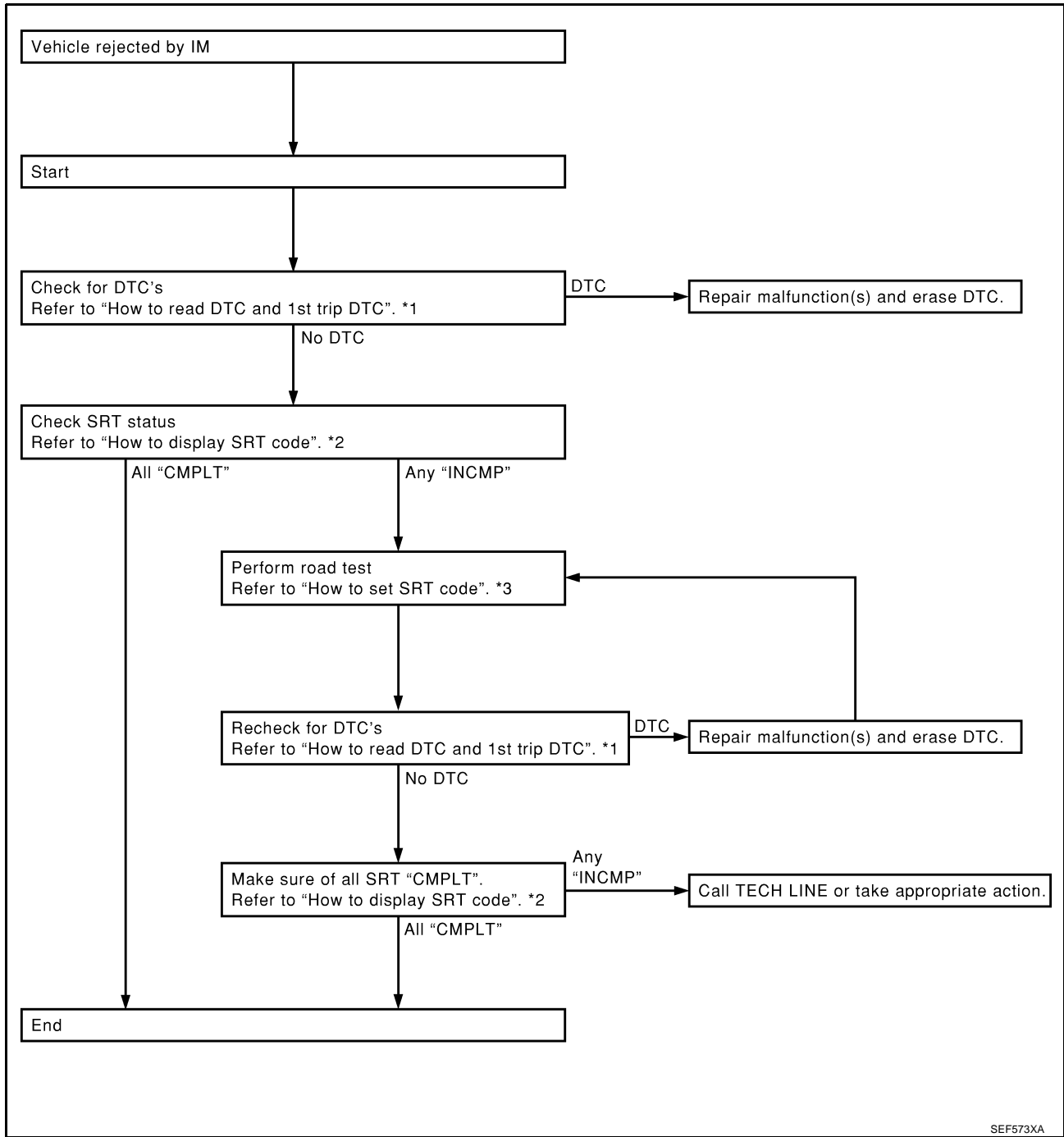

*1 [EC-58](#)

*2 [EC-62](#)

*3 [EC-63](#)

SEF573XA

How to Display SRT Code

WITH CONSULT-II

Selecting "SRT STATUS" in "DTC CONFIRMATION" mode with CONSULT-II.

For items whose SRT codes are set, a "CMPLT" is displayed on the CONSULT-II screen; for items whose SRT codes are not set, "INCMP" is displayed.

A sample of CONSULT-II display for SRT code is shown at right.

"INCMP" means the self-diagnosis is incomplete and SRT is not set.

"CMPLT" means the self-diagnosis is complete and SRT is set.

WITH GST

Selecting MODE 1 with GST (Generic Scan Tool)

SRT STATUS	
CATALYST	CMPLT
EVAP SYSTEM	INCMP
HO2S HTR	CMPLT
HO2S	CMPLT

SEF935Z

How to Set SRT Code

To set all SRT codes, self-diagnosis for the items indicated above must be performed one or more times. Each diagnosis may require a long period of actual driving under various conditions.

WITH CONSULT-II

Perform corresponding DTC Confirmation Procedure one by one based on Performance Priority in the table on [EC-60. "SRT Item"](#).

WITHOUT CONSULT-II

The most efficient driving pattern in which SRT codes can be properly set is explained on the next page. The driving pattern should be performed one or more times to set all SRT codes.

A
EC
C
D
E
F
G
H
I
J
K
L
M

Driving Pattern

Note: Always drive vehicle in safe manner according to traffic conditions and obey all traffic laws. Refer to next page for more information and explanation of chart.

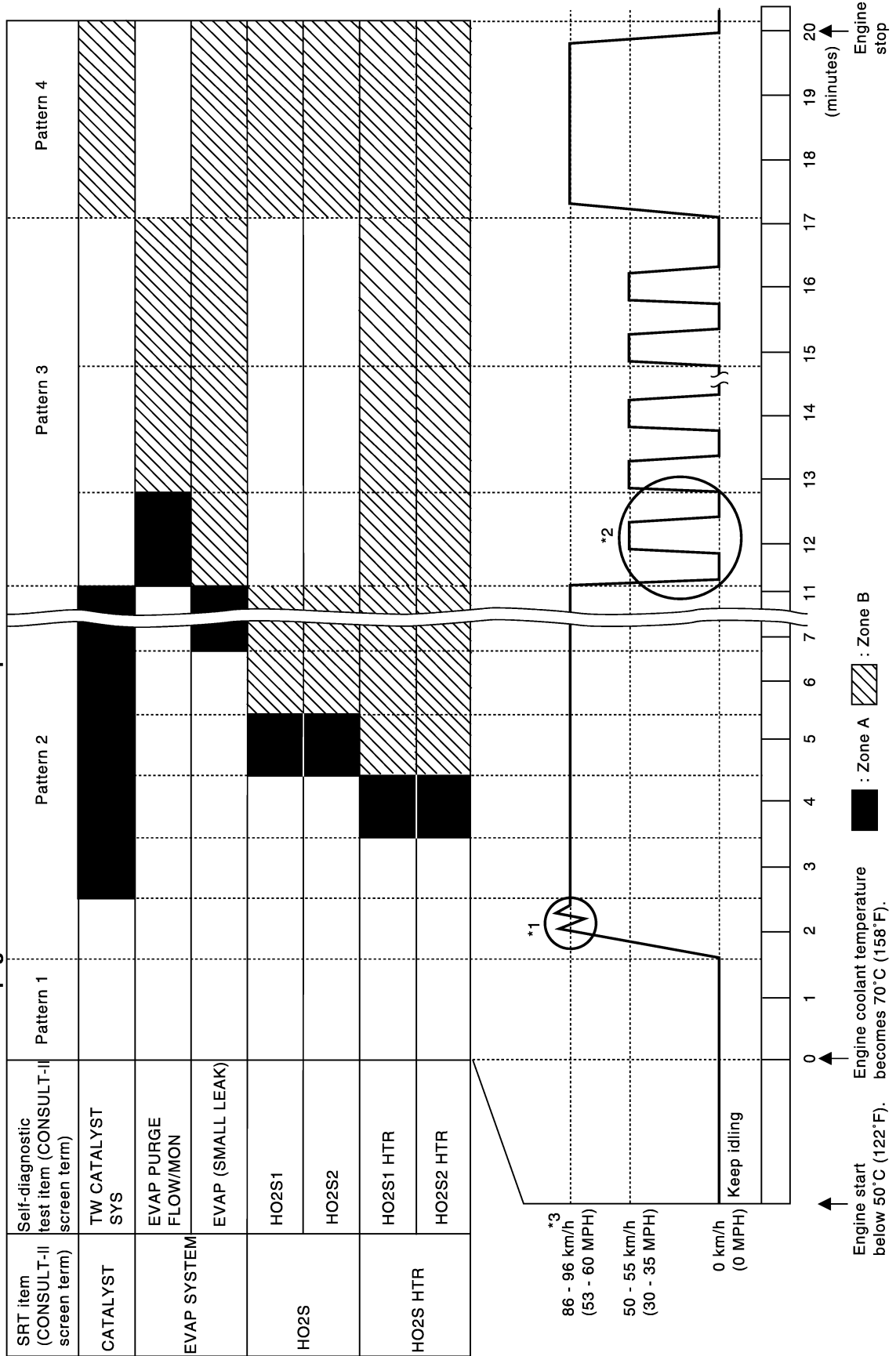

PBIB1053E

ON BOARD DIAGNOSTIC (OBD) SYSTEM

[VQ35DE]

- The time required for each diagnosis varies with road surface conditions, weather, altitude, individual driving habits, etc.
Zone A refers to the range where the time, required for the diagnosis under normal conditions*, is the shortest.
Zone B refers to the range where the diagnosis can still be performed if the diagnosis is not completed within zone A.

*: Normal conditions refer to the following:

- Sea level
- Flat road
- Ambient air temperature: 20 - 30°C (68 - 86°F)
- Diagnosis is performed as quickly as possible under normal conditions.
Under different conditions [For example: ambient air temperature other than 20 - 30°C (68 - 86°F)], diagnosis may also be performed.

Pattern 1:

- **The engine is started at the engine coolant temperature of -10 to 35°C (14 to 95°F) (where the voltage between the ECM terminal 73 and ground is 3.0 - 4.3V).**
- **The engine must be operated at idle speed until the engine coolant temperature is greater than 70°C (158°F) (where the voltage between the ECM terminal 73 and ground is lower than 1.4V).**
- **The engine is started at the fuel tank temperature of warmer than 0°C (32°F) (where the voltage between the ECM terminal 107 and ground is less than 4.1V).**

Pattern 2:

- When steady-state driving is performed again even after it is interrupted, each diagnosis can be conducted. In this case, the time required for diagnosis may be extended.

Pattern 3:

- The driving pattern outlined in *2 must be repeated at least 3 times.

Pattern 4:

- Tests are performed after the engine has been operated for at least 17 minutes.
- The accelerator pedal must be held very steady during steady-state driving.
- If the accelerator pedal is moved, the test must be conducted all over again.

*1: Depress the accelerator pedal until vehicle speed is 90 km/h (56 MPH), then release the accelerator pedal and keep it released for more than 10 seconds. Depress the accelerator pedal until vehicle speed is 90 km/h (56 MPH) again.

*2: Operate the vehicle in the following driving pattern.

1. Decelerate vehicle to 0 km/h (0 MPH) and let engine idle.
2. Repeat driving pattern shown at right at least 10 times.
- **During acceleration, hold the accelerator pedal as steady as possible.**

*3: Checking the vehicle speed with GST is advised.

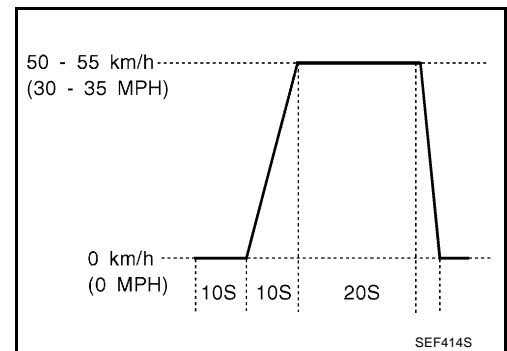

Suggested Transmission Gear Position

Set the selector lever in the D position.

TEST VALUE AND TEST LIMIT (GST ONLY — NOT APPLICABLE TO CONSULT-II)

The following is the information specified in Mode 6 of SAE J1979.

The test value is a parameter used to determine whether a system/circuit diagnostic test is OK or NG while being monitored by the ECM during self-diagnosis. The test limit is a reference value which is specified as the maximum or minimum value and is compared with the test value being monitored.

These data (test value and test limit) are specified by Test ID (TID) and Component ID (CID) and can be displayed on the GST screen.

×: Applicable —: Not applicable

ON BOARD DIAGNOSTIC (OBD) SYSTEM

[VQ35DE]

SRT item	Self-diagnostic test item	DTC	Test value (GST display)		Test limit	Application	Conversion
			TID	CID			
CATALYST	Three way catalyst function (Bank 1)	P0420	01H	01H	Max.	×	1/128
		P0420	02H	81H	Min.	×	1
	Three way catalyst function (Bank 2)	P0430	03H	02H	Max.	×	1/128
		P0430	04H	82H	Min.	×	1
EVAP SYSTEM	EVAP control system (Small leak)	P0442	05H	03H	Max.	×	1/128mm ²
	EVAP control system purge flow monitoring	P0441	06H	83H	Min.	×	20mV
	EVAP control system (Very small leak)	P0456	07H	03H	Max.	×	1/128mm ²
HO2S	Heated oxygen sensor 1 (Bank 1)	P0133	09H	04H	Max.	×	10ms
		P1143	0AH	84H	Min.	×	10mV
		P1144	0BH	04H	Max.	×	10mV
		P0132	0CH	04H	Max.	×	10mV
		P0134	0DH	04H	Max.	×	1s
	Heated oxygen sensor 1 (Bank 2)	P0153	11H	05H	Max.	×	10ms
		P1163	12H	85H	Min.	×	10mV
		P1164	13H	05H	Max.	×	10mV
		P0152	14H	05H	Max.	×	10mV
		P0154	15H	05H	Max.	×	1s
	Heated oxygen sensor 2 (Bank 1)	P0139	19H	86H	Min.	×	10mV/ 500ms
		P1147	1AH	86H	Min.	×	10mV
		P1146	1BH	06H	Max.	×	10mV
		P0138	1CH	06H	Max.	×	10mV
	Heated oxygen sensor 2 (Bank 2)	P0159	21H	87H	Min.	×	10mV/ 500ms
		P1167	22H	87H	Min.	×	10mV
P1166		23H	07H	Max.	×	10mV	
P0158		24H	07H	Max.	×	10mV	
HO2S HTR	Heated oxygen sensor 1 heater (Bank 1)	P0032	29H	08H	Max.	×	20mV
		P0031	2AH	88H	Min.	×	20mV
	Heated oxygen sensor 1 heater (Bank 2)	P0052	2BH	09H	Max.	×	20mV
		P0051	2CH	89H	Min.	×	20mV
	Heated oxygen sensor 2 heater (Bank 1)	P0038	2DH	0AH	Max.	×	20mV
		P0037	2EH	8AH	Min.	×	20mV
Heated oxygen sensor 2 heater (Bank 2)	P0058	2FH	0BH	Max.	×	20mV	
	P0057	30H	8BH	Min.	×	20mV	

HOW TO ERASE EMISSION-RELATED DIAGNOSTIC INFORMATION

How to Erase DTC

With CONSULT-II

The emission related diagnostic information in the ECM can be erased by selecting "ERASE" in the "SELF-DIAG RESULTS" mode with CONSULT-II.

If DTCs are displayed for both ECM and TCM (Transmission control module), they need to be erased individually from the ECM and TCM (Transmission control module).

NOTE:

If the DTC is not for A/T related items (see EC-15), skip steps 2 through 4.

1. If the ignition switch stays ON after repair work, be sure to turn ignition switch OFF once. Wait at least 10 seconds and then turn it ON (engine stopped) again.
2. Turn CONSULT-II ON and touch "A/T".
3. Touch "SELF-DIAG RESULTS".
4. Touch "ERASE". [The DTC in the TCM (Transmission control module) will be erased.] Then touch "BACK" twice.
5. Touch "ENGINE".
6. Touch "SELF-DIAG RESULTS".
7. Touch "ERASE". (The DTC in the ECM will be erased.)

How to erase DTC (With CONSULT-II)

1. If the ignition switch stays "ON" after repair work, be sure to turn ignition switch "OFF" once. Wait at least 10 seconds and then turn it "ON" (engine stopped) again.

SELECT SYSTEM
A/T
ENGINE

2. Turn CONSULT-II "ON", and touch "A/T".

SELECT DIAG MODE
SELF-DIAG RESULTS
DATE MONITOR
CAN DIAG SUPPORT MNTR
DTC WORK SUPPORT
ECU PART NUMBER

3. Touch "SELF-DIAG RESULTS".

SELF-DIAG RESULTS
DTC RESULTS
TCC SOLENOID/CIRC [P0740]

4. Touch "ERASE". (The DTC in the TCM will be erased.)

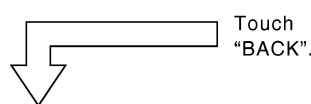

SELECT SYSTEM
A/T
ENGINE

5. Touch "ENGINE".

SELECT DIAG MODE
WORK SUPPORT
SELF-DIAG RESULTS
DATA MONITOR
DATA MONITOR(SPEC)
CAN DIAG SUPPORT MNTR
ACTIVE TEST

6. Touch "SELF-DIAG RESULTS".

SELF-DIAG RESULTS
DTC RESULTS
TCC SOLENOID/CIRC [P0740]
TIME
0

7. Touch "ERASE". (The DTC in the ECM will be erased.)

SCIA5334E

With GST

The emission related diagnostic information in the ECM can be erased by selecting MODE 4 with GST.

NOTE:

If the DTC is not for A/T related items (see EC-15), skip step 2.

1. If the ignition switch stays ON after repair work, be sure to turn ignition switch OFF once. Wait at least 10 seconds and then turn it ON (engine stopped) again.

2. Perform [AT-40](#) . (The DTC in TCM will be erased.)
3. Select MODE 4 with GST (Generic Scan Tool).

 **No Tools**

NOTE:

If the DTC is not for A/T related items (see [EC-15](#)), skip step 2.

1. If the ignition switch stays ON after repair work, be sure to turn ignition switch OFF once. Wait at least 10 seconds and then turn it ON (engine stopped) again.
 2. Perform [AT-41](#) . (The DTC in TCM will be erased.)
 3. Change the diagnostic test mode from Mode II to Mode I by depressing the accelerator pedal. Refer to [EC-70, "HOW TO SWITCH DIAGNOSTIC TEST MODE"](#) .
- **If the battery is disconnected, the emission-related diagnostic information will be lost within 24 hours.**
 - **The following data are cleared when the ECM memory is erased.**
 - Diagnostic trouble codes
 - 1st trip diagnostic trouble codes
 - Freeze frame data
 - 1st trip freeze frame data
 - System readiness test (SRT) codes
 - Test values
 - Others

Actual work procedures are explained using a DTC as an example. Be careful so that not only the DTC, but all of the data listed above, are cleared from the ECM memory during work procedures.

IVIS (Infiniti Vehicle Immobilizer System — NATS)

ABS008GC

- **If the security indicator lights up with the ignition switch in the ON position or “NATS MALFUNCTION” is displayed on “SELF-DIAG RESULTS” screen, perform self-diagnostic results mode with CONSULT-II using NATS program card. Refer to [BL-206, "IVIS \(INFINITI VEHICLE IMMOBILIZER SYSTEM-NATS\)"](#) .**
- **Confirm no self-diagnostic results of IVIS (NATS) is displayed before touching “ERASE” in “SELF-DIAG RESULTS” mode with CONSULT-II.**
- **When replacing ECM, initialization of IVIS (NATS) system and registration of all IVIS (NATS) ignition key IDs must be carried out with CONSULT-II using NATS program card.**

SELF DIAG RESULTS	
DTC RESULTS	TIME
NATS MALFUNCTION [P1610]	0

SEF543X

Therefore, be sure to receive all keys from vehicle owner. Regarding the procedures of IVIS (NATS) initialization and IVIS (NATS) ignition key ID registration, refer to CONSULT-II operation manual, IVIS/NVIS.

Malfunction Indicator Lamp (MIL)

ABS006KM

DESCRIPTION





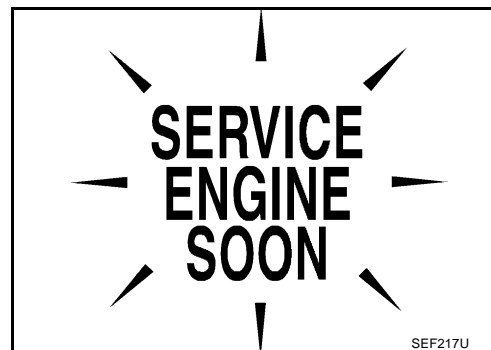

The MIL is located on the instrument panel.

1. The MIL will light up when the ignition switch is turned ON without the engine running. This is a bulb check. If the MIL does not light up, refer to [DI-39, "WARNING LAMPS"](#) , or see [EC-641](#) .
2. When the engine is started, the MIL should go off. If the MIL remains on, the on board diagnostic system has detected an engine system malfunction.



ON BOARD DIAGNOSTIC SYSTEM FUNCTION

The on board diagnostic system has the following four functions.

Diagnostic Test Mode	KEY and ENG. Status	Function	Explanation of Function
Mode I	Ignition switch in ON position  Engine stopped 	BULB CHECK	This function checks the MIL bulb for damage (blown, open circuit, etc.). If the MIL does not come on, check MIL circuit.
	Engine running 	MALFUNCTION WARNING	This is a usual driving condition. When a malfunction is detected twice in two consecutive driving cycles (two trip detection logic), the MIL will light up to inform the driver that a malfunction has been detected. The following malfunctions will light up or blink the MIL in the 1st trip. <ul style="list-style-type: none"> ● Misfire (Possible three way catalyst damage) ● One trip detection diagnoses
Mode II	Ignition switch in ON position  Engine stopped 	SELF-DIAGNOSTIC RESULTS	This function allows DTCs and 1st trip DTCs to be read.
	Engine running 	HEATED OXYGEN SENSOR 1 MONITOR	This function allows the fuel mixture condition (lean or rich), monitored by heated oxygen sensor 1, to be read.

When there is an open circuit on MIL circuit, the ECM cannot warn the driver by lighting MIL up when there is malfunction on engine control system.

Therefore, when electrical controlled throttle and part of ECM related diagnoses are continuously detected as NG for 5 trips, ECM warns the driver that engine control system malfunctions and MIL circuit is open by means of operating fail-safe function.

The fail-safe function also operates when above diagnoses except MIL circuit are detected and demands the driver to repair the malfunction.

Engine operating condition in fail-safe mode	Engine speed will not rise more than 2,500 rpm due to the fuel cut
--	--

MIL Flashing Without DTC

If the ECM is in Diagnostic Test Mode II, MIL may flash when engine is running. In this case, check ECM diagnostic test mode. [EC-70. "HOW TO SWITCH DIAGNOSTIC TEST MODE"](#) .

How to switch the diagnostic test (function) modes, and details of the above functions are described later. [EC-70. "HOW TO SWITCH DIAGNOSTIC TEST MODE"](#) .

The following emission-related diagnostic information is cleared when the ECM memory is erased.

- Diagnostic trouble codes
- 1st trip diagnostic trouble codes
- Freeze frame data
- 1st trip freeze frame data
- System readiness test (SRT) codes
- Test values
- Others

HOW TO SWITCH DIAGNOSTIC TEST MODE

NOTE:

- It is better to count the time accurately with a clock.
- It is impossible to switch the diagnostic mode when an accelerator pedal position sensor circuit has a malfunction.
- Always ECM returns to Diagnostic Test Mode I after ignition switch is turned OFF.

How to Set Diagnostic Test Mode II (Self-Diagnostic Results)

1. Confirm that accelerator pedal is fully released, turn ignition switch ON and wait 3 seconds.
2. Repeat the following procedure quickly five times within 5 seconds.
 - a. Fully depress the accelerator pedal.
 - b. Fully release the accelerator pedal.
3. Wait 7 seconds, fully depress the accelerator pedal and keep it for approx. 10 seconds until the MIL starts blinking.
4. Fully release the accelerator pedal.
ECM has entered to Diagnostic Test Mode II (Self-diagnostic results).

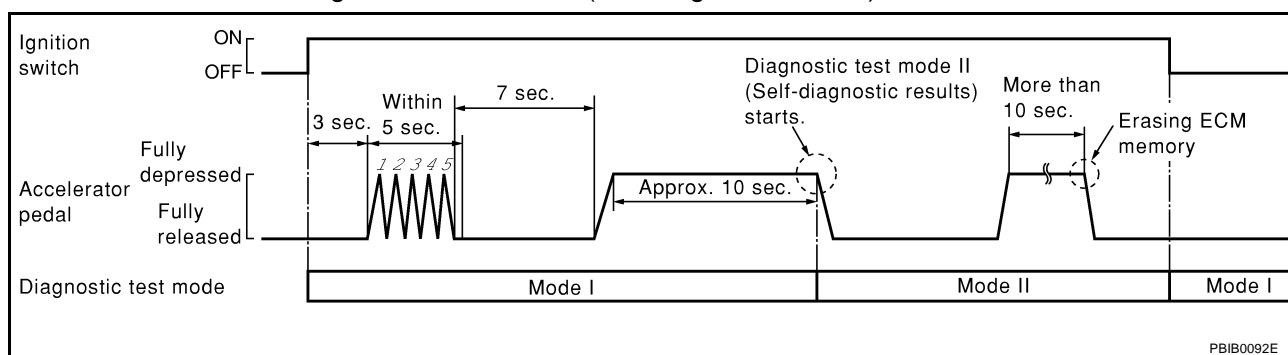

How to Set Diagnostic Test Mode II (Heated Oxygen Sensor 1 Monitor)

1. Set the ECM in Diagnostic Test Mode II (Self-diagnostic results). Refer to [EC-70, "How to Set Diagnostic Test Mode II \(Self-Diagnostic Results\)"](#).
2. Start Engine.
ECM has entered to Diagnostic Test Mode II (Heated oxygen sensor 1 monitor).
ECM will start heated oxygen sensor 1 monitoring from the bank 1 sensor.

How to Switch Monitored Sensor From Bank 1 to Bank 2 or Vice Versa

1. Fully depress the accelerator pedal quickly and then release it immediately.
2. Make sure that monitoring sensor has changed by MIL blinking as follows.

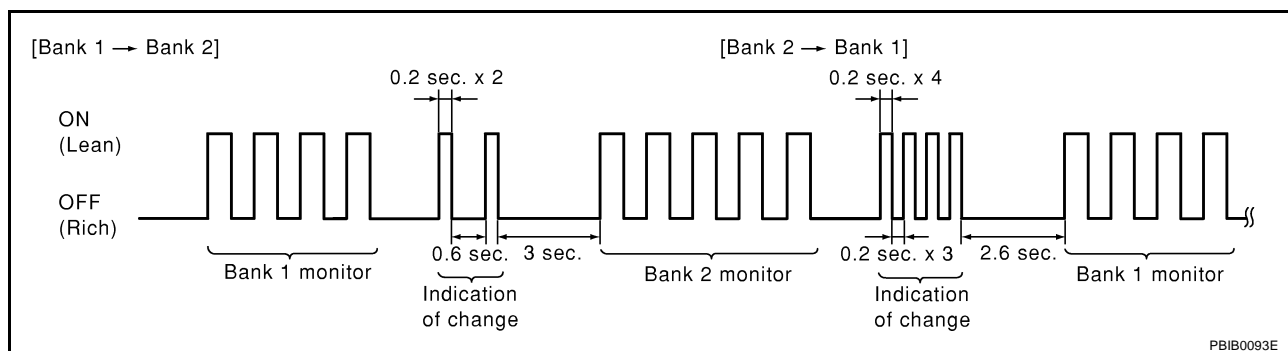

How to Erase Diagnostic Test Mode II (Self-Diagnostic Results)

1. Set ECM in Diagnostic Test Mode II (Self-diagnostic results). Refer to [EC-70, "How to Set Diagnostic Test Mode II \(Self-Diagnostic Results\)"](#).
2. Fully depress the accelerator pedal and keep it for more than 10 seconds.
The emission-related diagnostic information has been erased from the backup memory in the ECM.
3. Fully release the accelerator pedal, and confirm the DTC 0000 is displayed.

DIAGNOSTIC TEST MODE I — BULB CHECK

In this mode, the MIL on the instrument panel should stay ON. If it remains OFF, check the bulb. Refer to [DI-39, "WARNING LAMPS"](#) or see [EC-641](#).

DIAGNOSTIC TEST MODE I — MALFUNCTION WARNING

MIL	Condition
ON	When the malfunction is detected.
OFF	No malfunction.

This DTC number is clarified in Diagnostic Test Mode II (SELF-DIAGNOSTIC RESULTS)

DIAGNOSTIC TEST MODE II — SELF-DIAGNOSTIC RESULTS

In this mode, the DTC and 1st trip DTC are indicated by the number of blinks of the MIL as shown below. The DTC and 1st trip DTC are displayed at the same time. If the MIL does not illuminate in diagnostic test mode I (Malfunction warning), all displayed items are 1st trip DTCs. If only one code is displayed when the MIL illuminates in diagnostic test mode II (SELF-DIAGNOSTIC RESULTS), it is a DTC; if two or more codes are displayed, they may be either DTCs or 1st trip DTCs. DTC No. is same as that of 1st trip DTC. These unidentified codes can be identified by using the CONSULT-II or GST. A DTC will be used as an example for how to read a code.

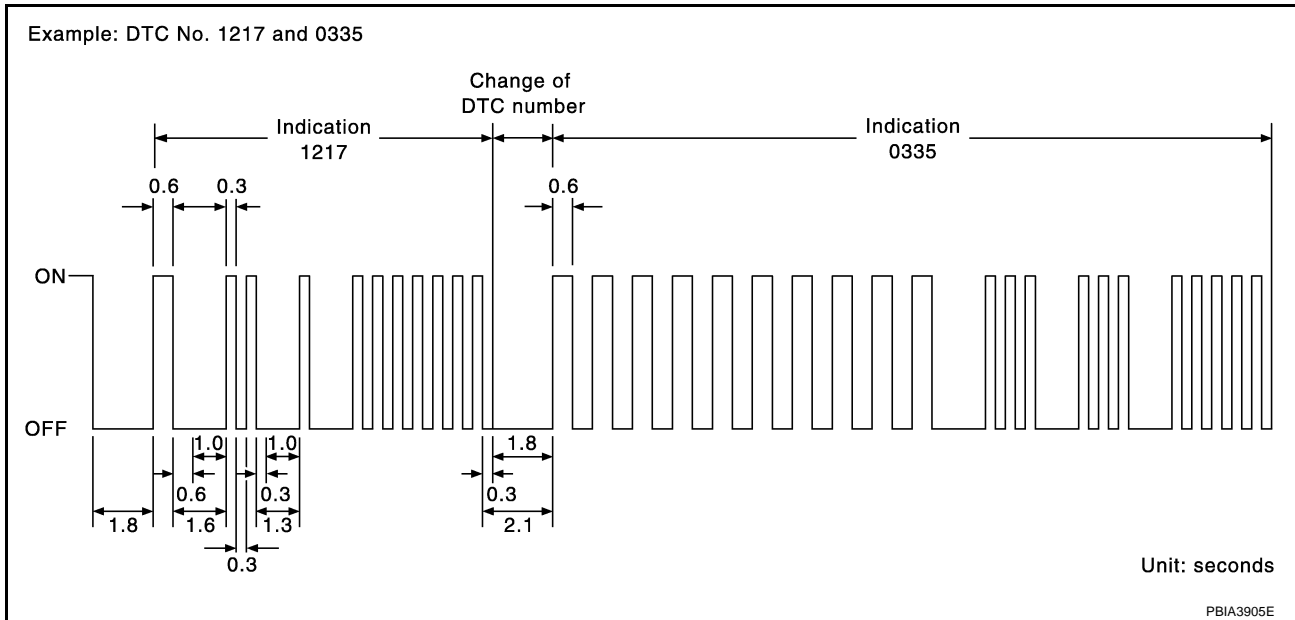

A particular trouble code can be identified by the number of four-digit numeral flashes. The "zero" is indicated by the number of ten flashes. The length of time the 1,000th-digit numeral flashes on and off is 1.2 seconds consisting of an ON (0.6-second) - OFF (0.6-second) cycle.

The 100th-digit numeral and lower digit numerals consist of a 0.3-second ON and 0.3-second OFF cycle.

A change from one digit numeral to another occurs at an interval of 1.0-second OFF. In other words, the later numeral appears on the display 1.3 seconds after the former numeral has disappeared.

A change from one trouble code to another occurs at an interval of 1.8-second OFF.

In this way, all the detected malfunctions are classified by their DTC numbers. The DTC 0000 refers to no malfunction. (See [EC-15, "INDEX FOR DTC"](#))

How to Erase Diagnostic Test Mode II (Self-Diagnostic Results)

The DTC can be erased from the back up memory in the ECM by depressing accelerator pedal. Refer to [EC-70, "How to Set Diagnostic Test Mode II \(Self-Diagnostic Results\)"](#).

- If the battery is disconnected, the DTC will be lost from the backup memory within 24 hours.
- Be careful not to erase the stored memory before starting trouble diagnoses.

DIAGNOSTIC TEST MODE II — HEATED OXYGEN SENSOR 1 MONITOR

In this mode, the MIL displays the condition of the fuel mixture (lean or rich) which is monitored by the heated oxygen sensor 1.

ON BOARD DIAGNOSTIC (OBD) SYSTEM

[VQ35DE]

MIL	Fuel mixture condition in the exhaust gas	Air fuel ratio feedback control condition
ON	Lean	Closed loop system
OFF	Rich	
*Remains ON or OFF	Any condition	Open loop system

*: Maintains conditions just before switching to open loop.

To check the heated oxygen sensor 1 function, start engine in the Diagnostic Test Mode II and warm it up until engine coolant temperature indicator points to the middle of the gauge.

Next run engine at about 2,000 rpm for about 2 minutes under no-load conditions. Then make sure that the MIL comes ON more than 5 times within 10 seconds with engine running at 2,000 rpm under no-load.

OBD System Operation Chart

ABS006KN

RELATIONSHIP BETWEEN MIL, 1ST TRIP DTC, DTC, AND DETECTABLE ITEMS

- When a malfunction is detected for the first time, the 1st trip DTC and the 1st trip freeze frame data are stored in the ECM memory.
- When the same malfunction is detected in two consecutive trips, the DTC and the freeze frame data are stored in the ECM memory, and the MIL will come on. For details, refer to [EC-53, "Two Trip Detection Logic"](#).
- The MIL will go off after the vehicle is driven 3 times with no malfunction. The drive is counted only when the recorded driving pattern is met (as stored in the ECM). If another malfunction occurs while counting, the counter will reset.
- The DTC and the freeze frame data will be stored until the vehicle is driven 40 times (driving pattern A) without the same malfunction recurring (except for Misfire and Fuel Injection System). For Misfire and Fuel Injection System, the DTC and freeze frame data will be stored until the vehicle is driven 80 times (driving pattern C) without the same malfunction recurring. The "TIME" in "SELF-DIAGNOSTIC RESULTS" mode of CONSULT-II will count the number of times the vehicle is driven.
- The 1st trip DTC is not displayed when the self-diagnosis results in OK for the 2nd trip.

SUMMARY CHART

Items	Fuel Injection System	Misfire	Other
MIL (goes off)	3 (pattern B)	3 (pattern B)	3 (pattern B)
DTC, Freeze Frame Data (no display)	80 (pattern C)	80 (pattern C)	40 (pattern A)
1st Trip DTC (clear)	1 (pattern C), *1	1 (pattern C), *1	1 (pattern B)
1st Trip Freeze Frame Data (clear)	*1, *2	*1, *2	1 (pattern B)

For details about patterns B and C under "Fuel Injection System" and "Misfire", see [EC-74](#).

For details about patterns A and B under Other, see [EC-76](#).

*1: Clear timing is at the moment OK is detected.

*2: Clear timing is when the same malfunction is detected in the 2nd trip.

RELATIONSHIP BETWEEN MIL, DTC, 1ST TRIP DTC AND DRIVING PATTERNS FOR "MISFIRE" "EXHAUST QUALITY DETERIORATION", "FUEL INJECTION SYSTEM"

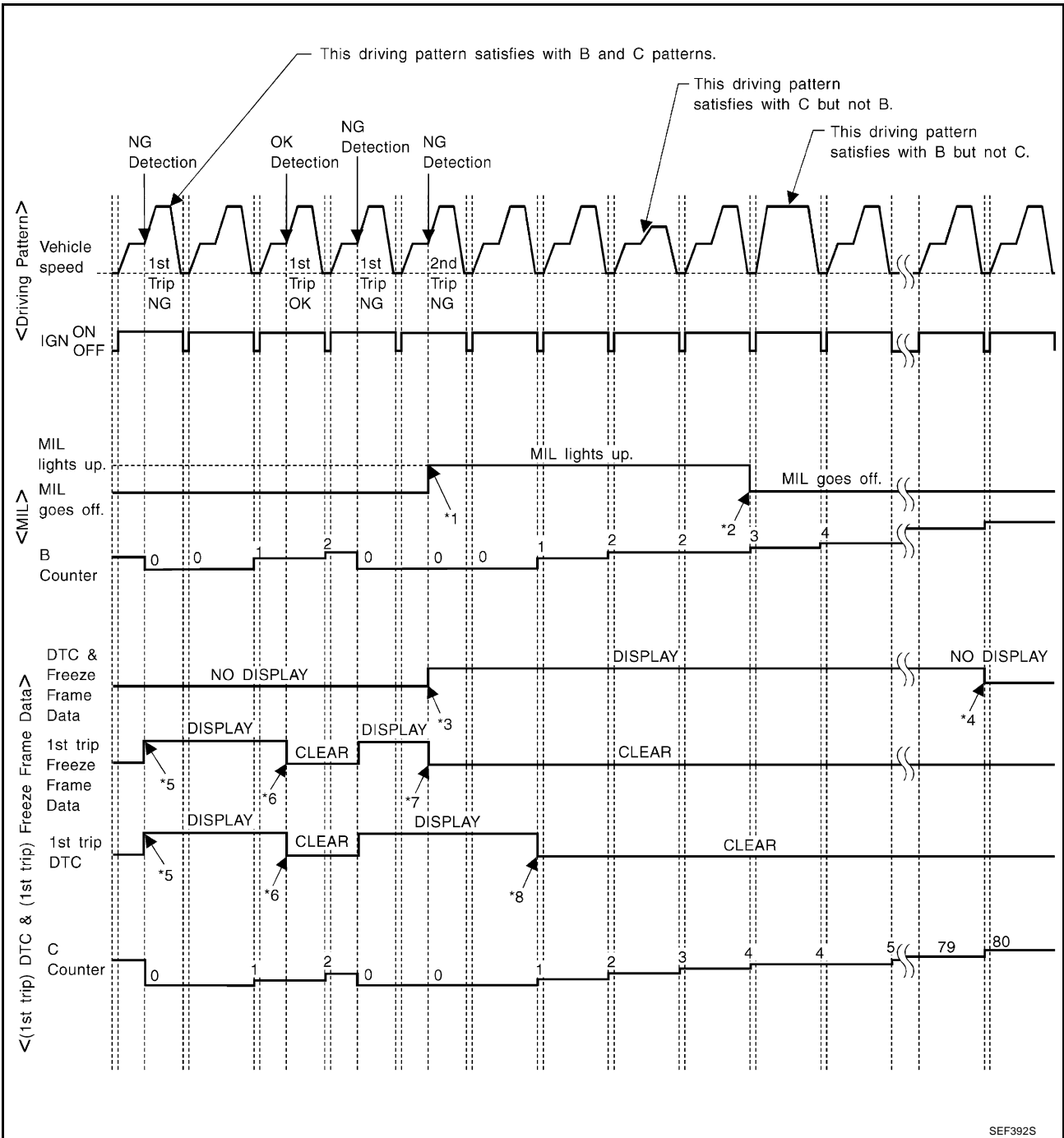

- *1: When the same malfunction is detected in two consecutive trips, MIL will light up.
- *2: MIL will go off after vehicle is driven 3 times (pattern B) without any malfunctions.
- *3: When the same malfunction is detected in two consecutive trips, the DTC and the freeze frame data will be stored in ECM.
- *4: The DTC and the freeze frame data will not be displayed any longer after vehicle is driven 80 times (pattern C) without the same malfunction. (The DTC and the freeze frame data still remain in ECM.)
- *5: When a malfunction is detected for the first time, the 1st trip DTC and the 1st trip freeze frame data will be stored in ECM.
- *6: The 1st trip DTC and the 1st trip freeze frame data will be cleared at the moment OK is detected.
- *7: When the same malfunction is detected in the 2nd trip, the 1st trip freeze frame data will be cleared.
- *8: 1st trip DTC will be cleared when vehicle is driven once (pattern C) without the same malfunction after DTC is stored in ECM.

EXPLANATION FOR DRIVING PATTERNS FOR “MISFIRE <EXHAUST QUALITY DETERIORATION>”, “FUEL INJECTION SYSTEM”

<Driving Pattern B>

Driving pattern B means the vehicle operation as follows:

All components and systems should be monitored at least once by the OBD system.

- The B counter will be cleared when the malfunction is detected once regardless of the driving pattern.
- The B counter will be counted up when driving pattern B is satisfied without any malfunction.
- The MIL will go off when the B counter reaches 3. (*2 in “OBD SYSTEM OPERATION CHART”)

<Driving Pattern C>

Driving pattern C means the vehicle operation as follows:

The following conditions should be satisfied at the same time:

Engine speed: (Engine speed in the freeze frame data) ± 375 rpm

Calculated load value: (Calculated load value in the freeze frame data) $\times (1 \pm 0.1)$ [%]

Engine coolant temperature (T) condition:

- When the freeze frame data shows lower than 70°C (158°F), T should be lower than 70°C (158°F).
- When the freeze frame data shows higher than or equal to 70°C (158°F), T should be higher than or equal to 70°C (158°F).

Example:

If the stored freeze frame data is as follows:

Engine speed: 850 rpm, Calculated load value: 30%, Engine coolant temperature: 80°C (176°F)

To be satisfied with driving pattern C, the vehicle should run under the following conditions:

Engine speed: 475 - 1,225 rpm, Calculated load value: 27 - 33%, Engine coolant temperature: more than 70°C (158°F)

- The C counter will be cleared when the malfunction is detected regardless of vehicle conditions above.
- The C counter will be counted up when vehicle conditions above is satisfied without the same malfunction.
- The DTC will not be displayed after C counter reaches 80.
- The 1st trip DTC will be cleared when C counter is counted once without the same malfunction after DTC is stored in ECM.

RELATIONSHIP BETWEEN MIL, DTC, 1ST TRIP DTC AND DRIVING PATTERNS EXCEPT FOR "MISFIRE <EXHAUST QUALITY DETERIORATION>", "FUEL INJECTION SYSTEM"

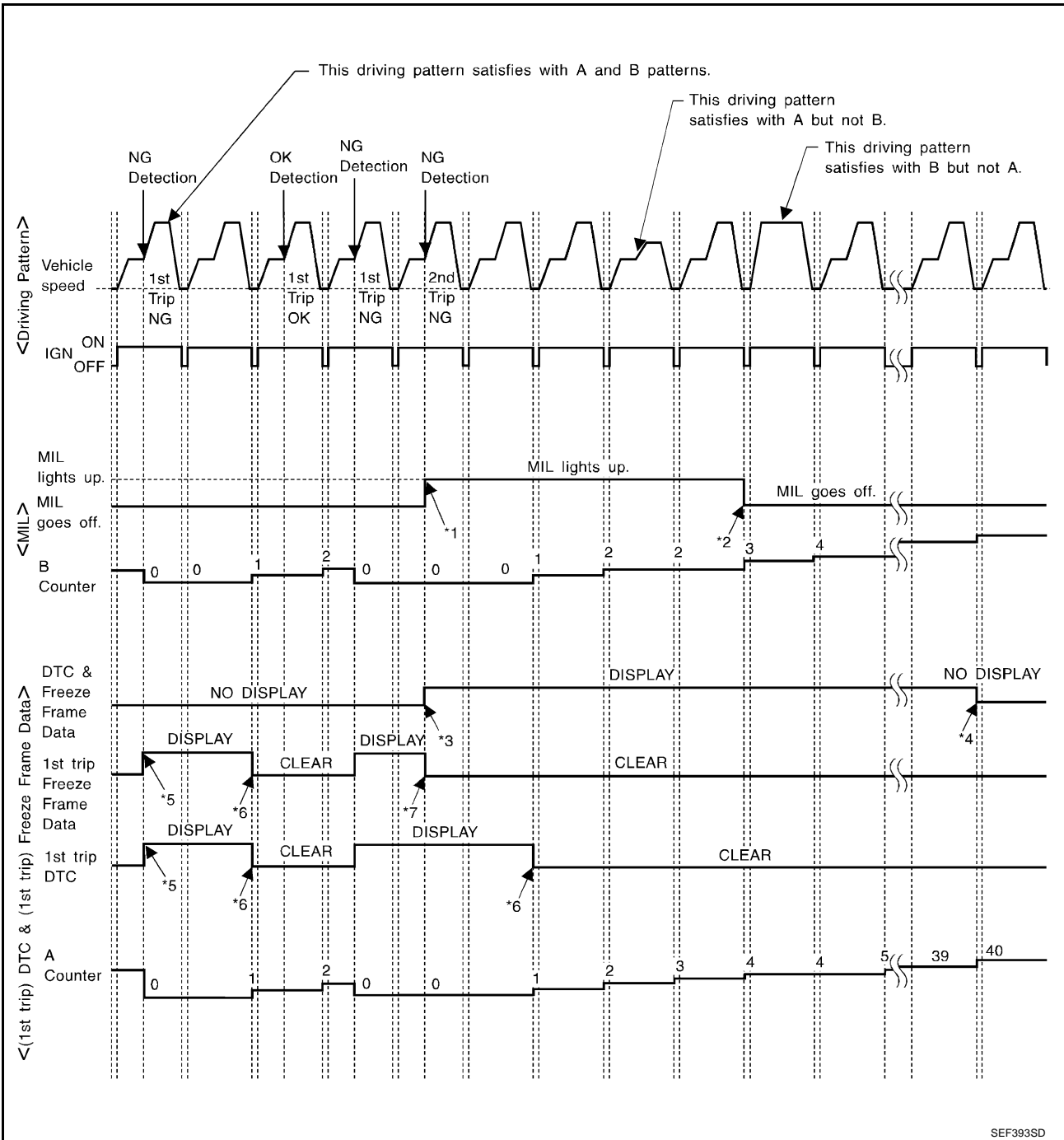

- *1: When the same malfunction is detected in two consecutive trips, MIL will light up.
- *2: MIL will go off after vehicle is driven 3 times (pattern B) without any malfunctions.
- *3: When the same malfunction is detected in two consecutive trips, the DTC and the freeze frame data will be stored in ECM.
- *4: The DTC and the freeze frame data will not be displayed any longer after vehicle is driven 40 times (pattern A) without the same malfunction. (The DTC and the freeze frame data still remain in ECM.)
- *5: When a malfunction is detected for the first time, the 1st trip DTC and the 1st trip freeze frame data will be stored in ECM.
- *6: 1st trip DTC will be cleared after vehicle is driven once (pattern B) without the same malfunction.
- *7: When the same malfunction is detected in the 2nd trip, the 1st trip freeze frame data will be cleared.

EXPLANATION FOR DRIVING PATTERNS EXCEPT FOR "MISFIRE <EXHAUST QUALITY DETERIORATION>", "FUEL INJECTION SYSTEM"

<Driving Pattern A>

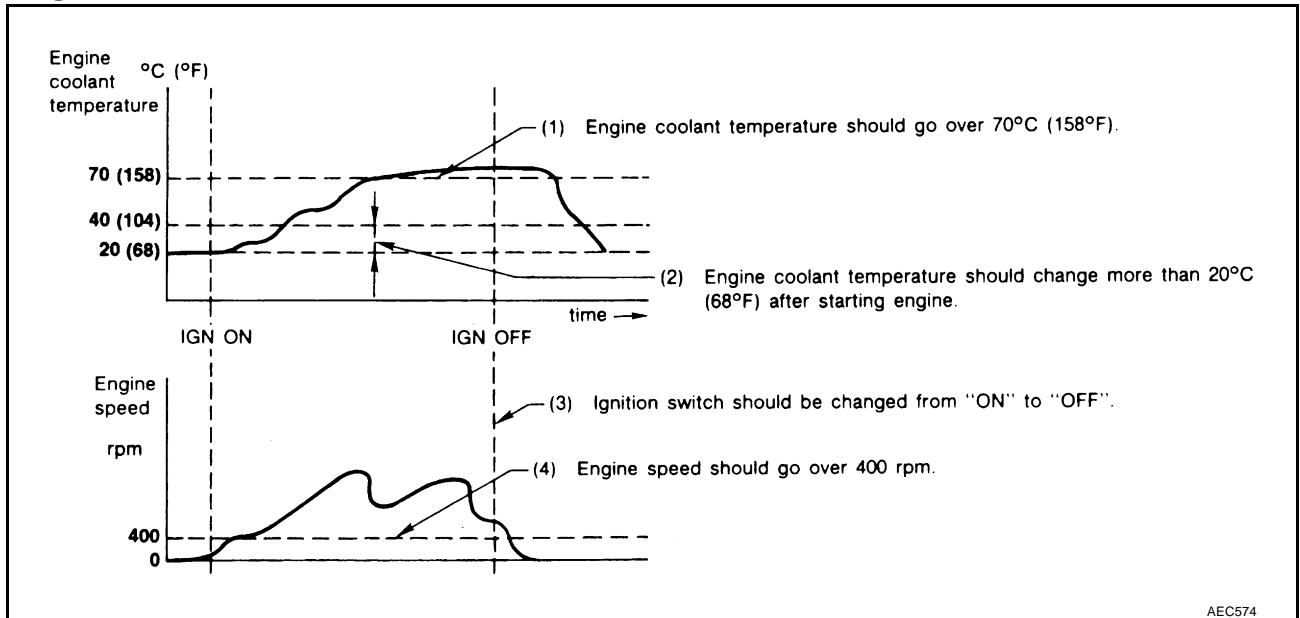

- The A counter will be cleared when the malfunction is detected regardless of (1) - (4).
- The A counter will be counted up when (1) - (4) are satisfied without the same malfunction.
- The DTC will not be displayed after the A counter reaches 40.

<Driving Pattern B>

Driving pattern B means the vehicle operation as follows:

All components and systems should be monitored at least once by the OBD system.

- The B counter will be cleared when the malfunction is detected once regardless of the driving pattern.
- The B counter will be counted up when driving pattern B is satisfied without any malfunctions.
- The MIL will go off when the B counter reaches 3 (*2 in OBD SYSTEM OPERATION CHART).

TROUBLE DIAGNOSIS

PFP:00004

Trouble Diagnosis Introduction
INTRODUCTION

ABS006KO

The engine has an ECM to control major systems such as fuel control, ignition control, idle air control system, etc. The ECM accepts input signals from sensors and instantly drives actuators. It is essential that both input and output signals are proper and stable. At the same time, it is important that there are no malfunctions such as vacuum leaks, fouled spark plugs, or other malfunctions with the engine.

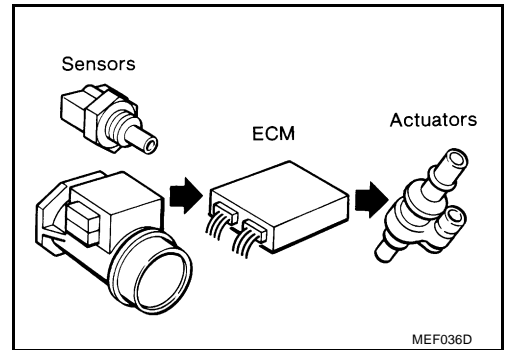

It is much more difficult to diagnose an incident that occurs intermittently rather than continuously. Most intermittent incidents are caused by poor electric connections or improper wiring. In this case, careful checking of suspected circuits may help prevent the replacement of good parts.

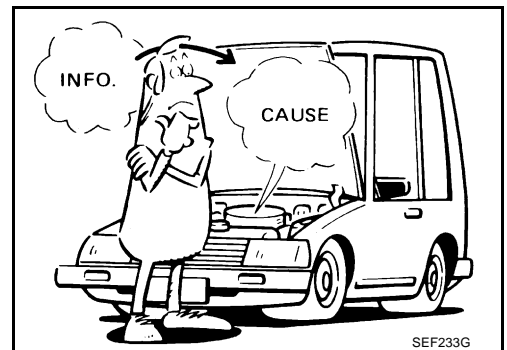

A visual check only may not find the cause of the incidents. A road test with CONSULT-II (or GST) or a circuit tester connected should be performed. Follow the Work Flow on [EC-78](#).

Before undertaking actual checks, take a few minutes to talk with a customer who approaches with a driveability complaint. The customer can supply good information about such incidents, especially intermittent ones. Find out what symptoms are present and under what conditions they occur. A Diagnostic Worksheet like the example on [EC-80](#) should be used.

Start your diagnosis by looking for conventional malfunctions first. This will help troubleshoot driveability malfunctions on an electronically controlled engine vehicle.

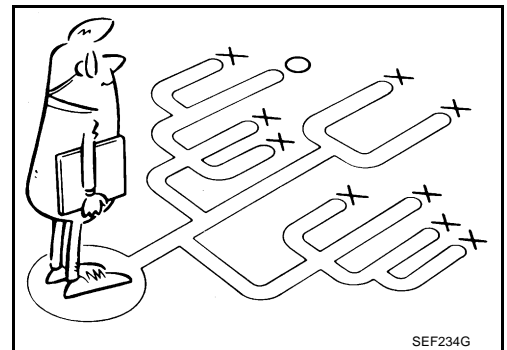

WORK FLOW Flow Chart

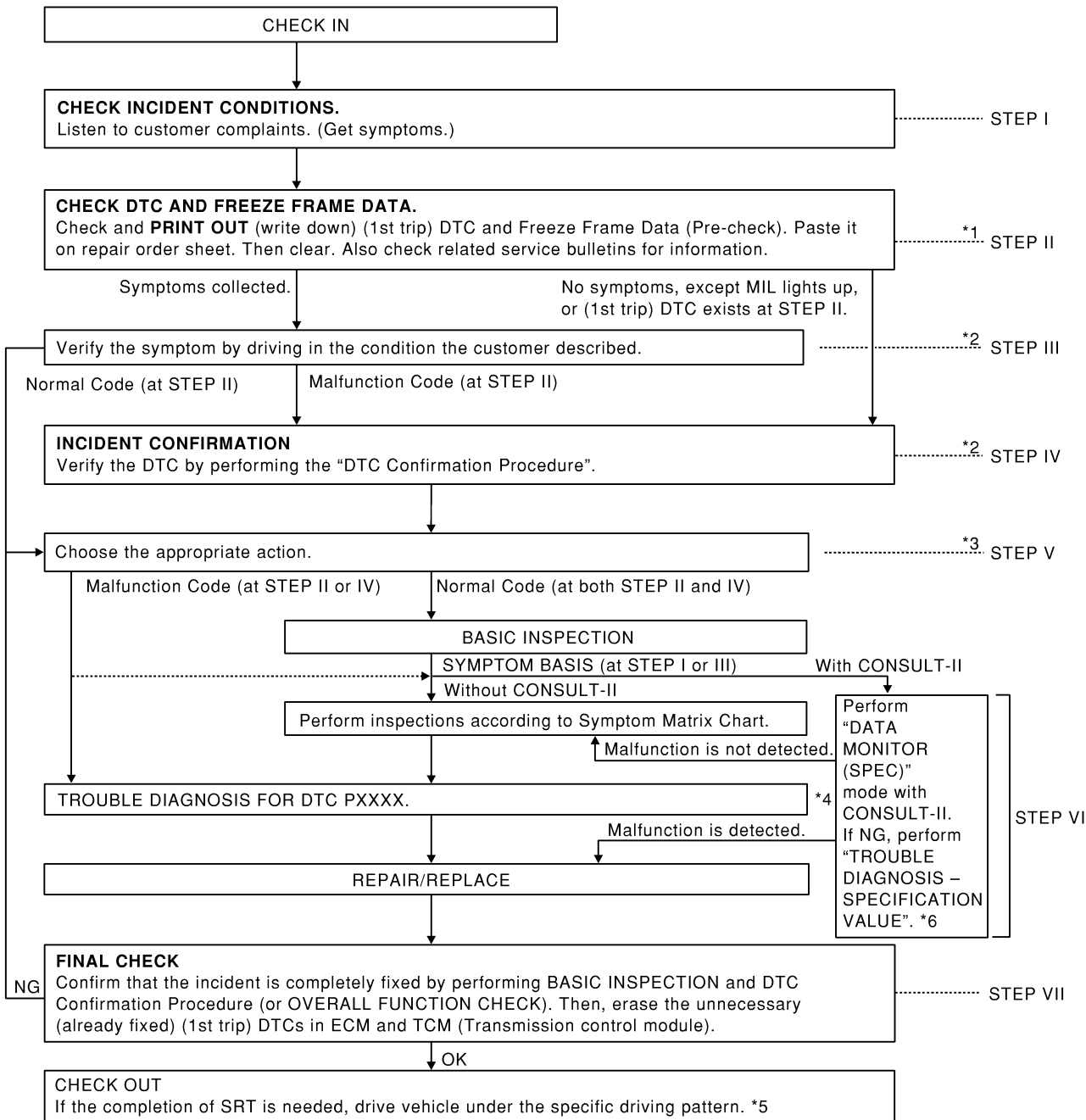

PBIB1043E

*1 If time data of "SELF-DIAG RESULTS" is other than "0" or "[1t]", perform [EC-135. "TROUBLE DIAGNOSIS FOR INTERMITTENT INCIDENT"](#) .

*2 If the incident cannot be verified, perform [EC-135. "TROUBLE DIAGNOSIS FOR INTERMITTENT INCIDENT"](#) .

*3 If the on board diagnostic system cannot be performed, check main power supply and ground circuit. Refer to [EC-136. "POWER SUPPLY AND GROUND CIRCUIT"](#) .

*4 If malfunctioning part cannot be detected, perform [EC-135. "TROUBLE DIAGNOSIS FOR INTERMITTENT INCIDENT"](#) .

*5 [EC-64](#)

*6 [EC-131](#)

TROUBLE DIAGNOSIS

[VQ35DE]

Description for Work Flow

STEP	DESCRIPTION
STEP I	Get detailed information about the conditions and the environment when the incident/symptom occurred using the "DIAGNOSTIC WORK SHEET", EC-79 .
STEP II	Before confirming the concern, check and write down (print out using CONSULT-II or GST) the (1st trip) DTC and the (1st trip) freeze frame data, then erase the DTC and the data. (Refer to EC-67 .) The (1st trip) DTC and the (1st trip) freeze frame data can be used when duplicating the incident at STEP III & IV. If the incident cannot be verified, perform EC-135. "TROUBLE DIAGNOSIS FOR INTERMITTENT INCIDENT" . Study the relationship between the cause, specified by (1st trip) DTC, and the symptom described by the customer. (The Symptom Matrix Chart will be useful. See EC-88 .) Also check related service bulletins for information.
STEP III	Try to confirm the symptom and under what conditions the incident occurs. The DIAGNOSTIC WORK SHEET and the freeze frame data are useful to verify the incident. Connect CONSULT-II to the vehicle in "DATA MONITOR (AUTO TRIG)" mode and check real time diagnosis results. If the incident cannot be verified, perform EC-135. "TROUBLE DIAGNOSIS FOR INTERMITTENT INCIDENT" . If the malfunction code is detected, skip STEP IV and perform STEP V.
STEP IV	Try to detect the (1st trip) DTC by driving in (or performing) the DTC Confirmation Procedure. Check and read the (1st trip) DTC and (1st trip) freeze frame data by using CONSULT-II or GST. During the (1st trip) DTC verification, be sure to connect CONSULT-II to the vehicle in "DATA MONITOR (AUTO TRIG)" mode and check real time diagnosis results. If the incident cannot be verified, perform EC-135. "TROUBLE DIAGNOSIS FOR INTERMITTENT INCIDENT" . In case the DTC Confirmation Procedure is not available, perform the Overall Function Check instead. The (1st trip) DTC cannot be displayed by this check, however, this simplified check is an effective alternative. The NG result of the Overall Function Check is the same as the (1st trip) DTC detection.
STEP V	Take the appropriate action based on the results of STEP I through IV. If the malfunction code is indicated, proceed to TROUBLE DIAGNOSIS FOR DTC PXXXX. If the normal code is indicated, proceed to the BASIC INSPECTION. (Refer to EC-83 .) Then perform inspections according to the Symptom Matrix Chart. (Refer to EC-88 .)
STEP VI	Identify where to begin diagnosis based on the relationship study between symptom and possible causes. Inspect the system for mechanical binding, loose connectors or wiring damage using (tracing) Harness Layouts. Gently shake the related connectors, components or wiring harness with CONSULT-II set in "DATA MONITOR (AUTO TRIG)" mode. Check the voltage of the related ECM terminals or monitor the output data from the related sensors with CONSULT-II. Refer to EC-100 , EC-125 . The Diagnostic Procedure in EC section contains a description based on open circuit inspection. A short circuit inspection is also required for the circuit check in the Diagnostic Procedure. For details, refer to Circuit Inspection in GI-27. "How to Perform Efficient Diagnosis for an Electrical Incident" . Repair or replace the malfunction parts. If malfunctioning part cannot be detected, perform EC-135. "TROUBLE DIAGNOSIS FOR INTERMITTENT INCIDENT" .
STEP VII	Once you have repaired the circuit or replaced a component, you need to run the engine in the same conditions and circumstances which resulted in the customer's initial complaint. Perform the DTC Confirmation Procedure and confirm the normal code [DTC No. P0000] is detected. If the incident is still detected in the final check, perform STEP VI by using a method different from the previous one. Before returning the vehicle to the customer, be sure to erase the unnecessary (already fixed) (1st trip) DTC in ECM and TCM (Transmission control module). (Refer to EC-67. "HOW TO ERASE EMISSION-RELATED DIAGNOSTIC INFORMATION" and AT-39. "HOW TO ERASE DTC" .)

DIAGNOSTIC WORKSHEET

Description

There are many operating conditions that lead to the malfunction of engine components. A good grasp of such conditions can make troubleshooting faster and more accurate.

In general, each customer feels differently about a incident. It is important to fully understand the symptoms or conditions for a customer complaint.

Utilize a diagnostic worksheet like the one on the next page in order to organize all the information for troubleshooting.

Some conditions may cause the MIL to come on steady or blink and DTC to be detected. Examples:

- Vehicle ran out of fuel, which caused the engine to misfire.

KEY POINTS

WHAT Vehicle & engine model
WHEN Date, Frequencies
WHERE..... Road conditions
HOW Operating conditions,
 Weather conditions,
 Symptoms

SEF907L

TROUBLE DIAGNOSIS

[VQ35DE]

- Fuel filler cap was left off or incorrectly screwed on, allowing fuel to evaporate into the atmosphere.

Worksheet Sample

Customer name MR/MS		Model & Year	VIN				
Engine #		Trans.	Mileage				
Incident Date		Manuf. Date	In Service Date				
Fuel and fuel filler cap		<input type="checkbox"/> Vehicle ran out of fuel causing misfire <input type="checkbox"/> Fuel filler cap was left off or incorrectly screwed on.					
Symptoms	<input type="checkbox"/> Startability	<input type="checkbox"/> Impossible to start <input type="checkbox"/> No combustion <input type="checkbox"/> Partial combustion <input type="checkbox"/> Partial combustion affected by throttle position <input type="checkbox"/> Partial combustion NOT affected by throttle position <input type="checkbox"/> Possible but hard to start <input type="checkbox"/> Others []					
	<input type="checkbox"/> Idling	<input type="checkbox"/> No fast idle <input type="checkbox"/> Unstable <input type="checkbox"/> High idle <input type="checkbox"/> Low idle <input type="checkbox"/> Others []					
	<input type="checkbox"/> Driveability	<input type="checkbox"/> Stumble <input type="checkbox"/> Surge <input type="checkbox"/> Knock <input type="checkbox"/> Lack of power <input type="checkbox"/> Intake backfire <input type="checkbox"/> Exhaust backfire <input type="checkbox"/> Others []					
	<input type="checkbox"/> Engine stall	<input type="checkbox"/> At the time of start <input type="checkbox"/> While idling <input type="checkbox"/> While accelerating <input type="checkbox"/> While decelerating <input type="checkbox"/> Just after stopping <input type="checkbox"/> While loading					
Incident occurrence		<input type="checkbox"/> Just after delivery <input type="checkbox"/> Recently <input type="checkbox"/> In the morning <input type="checkbox"/> At night <input type="checkbox"/> In the daytime					
Frequency		<input type="checkbox"/> All the time <input type="checkbox"/> Under certain conditions <input type="checkbox"/> Sometimes					
Weather conditions		<input type="checkbox"/> Not affected					
		<table border="1" style="width: 100%; border-collapse: collapse;"> <tr> <td style="width: 20%;">Weather</td> <td> <input type="checkbox"/> Fine <input type="checkbox"/> Raining <input type="checkbox"/> Snowing <input type="checkbox"/> Others [] </td> </tr> <tr> <td>Temperature</td> <td> <input type="checkbox"/> Hot <input type="checkbox"/> Warm <input type="checkbox"/> Cool <input type="checkbox"/> Cold <input type="checkbox"/> Humid °F </td> </tr> </table>		Weather	<input type="checkbox"/> Fine <input type="checkbox"/> Raining <input type="checkbox"/> Snowing <input type="checkbox"/> Others []	Temperature	<input type="checkbox"/> Hot <input type="checkbox"/> Warm <input type="checkbox"/> Cool <input type="checkbox"/> Cold <input type="checkbox"/> Humid °F
Weather	<input type="checkbox"/> Fine <input type="checkbox"/> Raining <input type="checkbox"/> Snowing <input type="checkbox"/> Others []						
Temperature	<input type="checkbox"/> Hot <input type="checkbox"/> Warm <input type="checkbox"/> Cool <input type="checkbox"/> Cold <input type="checkbox"/> Humid °F						
Engine conditions		<input type="checkbox"/> Cold <input type="checkbox"/> During warm-up <input type="checkbox"/> After warm-up Engine speed <div style="text-align: center;"> </div>					
Road conditions		<input type="checkbox"/> In town <input type="checkbox"/> In suburbs <input type="checkbox"/> Highway <input type="checkbox"/> Off road (up/down)					
Driving conditions		<input type="checkbox"/> Not affected <input type="checkbox"/> At starting <input type="checkbox"/> While idling <input type="checkbox"/> At racing <input type="checkbox"/> While accelerating <input type="checkbox"/> While cruising <input type="checkbox"/> While decelerating <input type="checkbox"/> While turning (RH/LH) Vehicle speed <div style="text-align: center;"> </div>					
Malfunction indicator lamp		<input type="checkbox"/> Turned on <input type="checkbox"/> Not turned on					

MTBL0017

DTC Inspection Priority Chart

ABS006KP

If some DTCs are displayed at the same time, perform inspections one by one based on the following priority chart.

NOTE:

If DTC U1000 and/or U1001 is displayed with other DTC, first perform the trouble diagnosis for DTC U1000, U1001. Refer to [EC-142](#).

TROUBLE DIAGNOSIS

[VQ35DE]

Priority	Detected items (DTC)	
1	<ul style="list-style-type: none"> ● U1000 U1001 CAN communication line ● P0101 P0102 P0103 Mass air flow sensor ● P0112 P0113 P0127 Intake air temperature sensor ● P0117 P0118 P0125 Engine coolant temperature sensor ● P0128 Thermostat function ● P0122 P0123 P0222 P0223 P1225 P1226 P2135 Throttle position sensor ● P0181 P0182 P0183 Fuel tank temperature sensor ● P0327 P0328 Knock sensor ● P0335 Crankshaft position sensor (POS) ● P0340 P0345 Camshaft position sensor (PHASE) ● P0460 P0461 P0462 P0463 Fuel level sensor ● P0500 Vehicle speed sensor ● P0605 ECM ● P0705 Park/Neutral position (PNP) switch ● P1229 Sensor power supply ● P1610 - P1615 NATS ● P1706 Park/Neutral position (PNP) switch ● P2122 P2123 P2127 P2128 P2138 Accelerator pedal position sensor 	<p>A</p> <p>EC</p> <p>C</p> <p>D</p> <p>E</p> <p>F</p> <p>G</p>
2	<ul style="list-style-type: none"> ● P0031 P0032 P0051 P0052 Heated oxygen sensor 1 heater ● P0037 P0038 P0057 P0058 Heated oxygen sensor 2 heater ● P0132 P0133 P0134 P0152 P0153 P0154 P1143 P1144 P1163 P1164 Heated oxygen sensor 1 ● P0138 P0139 P0158 P0159 P1146 P1147 P1166 P1167 Heated oxygen sensor 2 ● P0441 EVAP control system purge flow monitoring ● P0444 P0445 P1444 EVAP canister purge volume control solenoid valve ● P0447 P1446 EVAP canister vent control valve ● P0451 P0452 P0453 EVAP control system pressure sensor ● P0550 Power steering pressure sensor ● P0710 P0720 P0725 P0740 P0744 P0745 P1705 P1716 P1730 P1752 P1754 P1757 P1759 P1762 P1764 P1767 P1769 P1772 P1774 A/T related sensors, solenoid valves and switches ● P1065 ECM power supply ● P1111 P1136 Intake valve timing control solenoid valve ● P1122 Electric throttle control function ● P1124 P1126 P1128 Electric throttle control actuator ● P1217 Engine over temperature (OVERHEAT) ● P1805 Brake switch 	<p>H</p> <p>I</p> <p>J</p> <p>K</p> <p>L</p> <p>M</p>
3	<ul style="list-style-type: none"> ● P0011 P0021 Intake valve timing control ● P0171 P0172 P0174 P0175 Fuel injection system function ● P0300 - P0306 Misfire ● P0420 P0430 Three way catalyst function ● P0442 P0455 P0456 EVAP control system ● P0506 P0507 Idle speed control system ● P1121 Electric throttle control actuator ● P1148 P1168 Closed loop control ● P1211 TCS control unit ● P1212 TCS communication line ● P1564 ICC steering switch/ASCD steering switch ● P1568 ICC command valve ● P1572 ICC brake switch/ASCD brake switch ● P1574 ICC vehicle speed sensor/ASCD vehicle speed sensor 	

TROUBLE DIAGNOSIS

[VQ35DE]

ABS006KQ

Fail-Safe Chart

When the DTC listed below is detected, the ECM enters fail-safe mode and the MIL lights up.

DTC No.	Detected items	Engine operating condition in fail-safe mode								
P0102 P0103	Mass air flow sensor circuit	Engine speed will not rise more than 2,400 rpm due to the fuel cut.								
P0117 P0118	Engine coolant temperature sensor circuit	<p>Engine coolant temperature will be determined by ECM based on the time after turning ignition switch ON or START. CONSULT-II displays the engine coolant temperature decided by ECM.</p> <table border="1" style="width: 100%; border-collapse: collapse;"> <thead> <tr> <th style="text-align: center;">Condition</th> <th style="text-align: center;">Engine coolant temperature decided (CONSULT-II display)</th> </tr> </thead> <tbody> <tr> <td>Just as ignition switch is turned ON or START</td> <td style="text-align: center;">40°C (104°F)</td> </tr> <tr> <td>More than approx. 4 minutes after ignition ON or START</td> <td style="text-align: center;">80°C (176°F)</td> </tr> <tr> <td>Except as shown above</td> <td style="text-align: center;">40 - 80°C (104 - 176°F) (Depends on the time)</td> </tr> </tbody> </table> <p>When the fail-safe system for engine coolant temperature sensor is activated, the cooling fan operates while engine is running.</p>	Condition	Engine coolant temperature decided (CONSULT-II display)	Just as ignition switch is turned ON or START	40°C (104°F)	More than approx. 4 minutes after ignition ON or START	80°C (176°F)	Except as shown above	40 - 80°C (104 - 176°F) (Depends on the time)
Condition	Engine coolant temperature decided (CONSULT-II display)									
Just as ignition switch is turned ON or START	40°C (104°F)									
More than approx. 4 minutes after ignition ON or START	80°C (176°F)									
Except as shown above	40 - 80°C (104 - 176°F) (Depends on the time)									
P0122 P0123 P0222 P0223 P2135	Throttle position sensor	<p>The ECM controls the electric throttle control actuator in regulating the throttle opening in order for the idle position to be within +10 degrees. The ECM regulates the opening speed of the throttle valve to be slower than the normal condition. So, the acceleration will be poor.</p>								
P1121	Electric throttle control actuator	<p>(When electric throttle control actuator does not function properly due to the return spring malfunction:) ECM controls the electric throttle actuator by regulating the throttle opening around the idle position. The engine speed will not rise more than 2,000 rpm.</p> <p>(When throttle valve opening angle in fail-safe mode is not in specified range:) ECM controls the electric throttle control actuator by regulating the throttle opening to 20 degrees or less.</p> <p>(When ECM detects the throttle valve is stuck open:) While the vehicle is driving, it slows down gradually by fuel cut. After the vehicle stops, the engine stalls. The engine can restart in N or P position, and engine speed will not exceed 1,000 rpm or more.</p>								
P1122	Electric throttle control function	ECM stops the electric throttle control actuator control, throttle valve is maintained at a fixed opening (approx. 5 degrees) by the return spring.								
P1124 P1126	Throttle control motor relay	ECM stops the electric throttle control actuator control, throttle valve is maintained at a fixed opening (approx. 5 degrees) by the return spring.								
P1128	Throttle control motor	ECM stops the electric throttle control actuator control, throttle valve is maintained at a fixed opening (approx. 5 degrees) by the return spring.								
P1229	Sensor power supply	ECM stops the electric throttle control actuator control, throttle valve is maintained at a fixed opening (approx. 5 degrees) by the return spring.								
P2122 P2123 P2127 P2128 P2138	Accelerator pedal position sensor	<p>The ECM controls the electric throttle control actuator in regulating the throttle opening in order for the idle position to be within +10 degrees. The ECM regulates the opening speed of the throttle valve to be slower than the normal condition. So, the acceleration will be poor.</p>								

- When there is an open circuit on MIL circuit, the ECM cannot warn the driver by lighting MIL up when there is malfunction on engine control system.
Therefore, when electrical controlled throttle and part of ECM related diagnoses are continuously detected as NG for 5 trips, ECM warns the driver that engine control system malfunctions and MIL circuit is open by means of operating fail-safe function.
The fail-safe function also operates when above diagnoses except MIL circuit are detected and demands the driver to repair the malfunction.

Engine operating condition in fail-safe mode

Engine speed will not rise more than 2,500 rpm due to the fuel cut

Basic Inspection**1. INSPECTION START**

1. Check service records for any recent repairs that may indicate a related malfunction, or a current need for scheduled maintenance.
2. Open engine hood and check the following:
 - Harness connectors for improper connections
 - Wiring harness for improper connections, pinches and cut
 - Vacuum hoses for splits, kinks and improper connections
 - Hoses and ducts for leaks
 - Air cleaner clogging
 - Gasket
3. Confirm that electrical or mechanical loads are not applied.
 - Headlamp switch is OFF.
 - Air conditioner switch is OFF.
 - Rear window defogger switch is OFF.
 - Steering wheel is in the straight-ahead position, etc.
4. Start engine and warm it up until engine coolant temperature indicator points the middle of gauge. Ensure engine stays below 1,000 rpm.

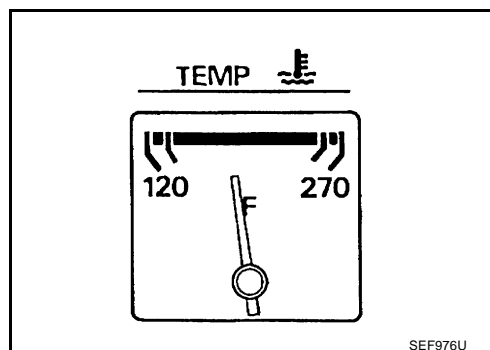
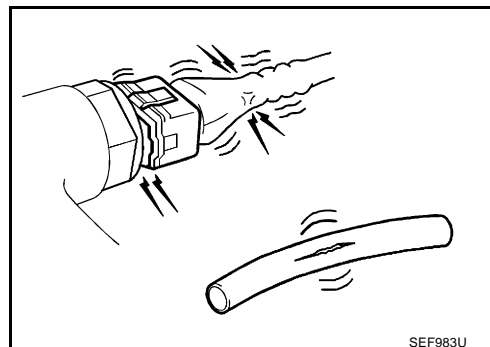

5. Run engine at about 2,000 rpm for about 2 minutes under no-load.
6. Make sure that no DTC is displayed with CONSULT-II or GST.

OK or NG

- OK >> GO TO 3.
 NG >> GO TO 2.

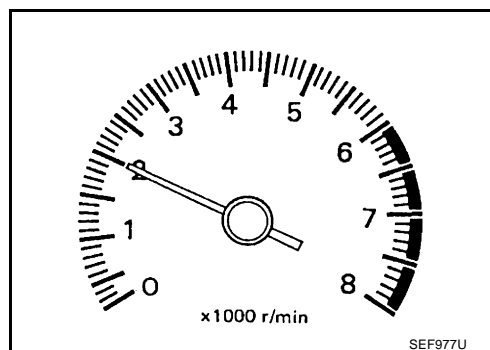
**2. REPAIR OR REPLACE**

Repair or replace components as necessary according to corresponding Diagnostic Procedure.

>> GO TO 3.

3. CHECK TARGET IDLE SPEED

④ With CONSULT-II

1. Run engine at about 2,000 rpm for about 2 minutes under no-load.
2. Rev engine (2,000 to 3,000 rpm) two or three times under no-load, then run engine at idle speed for about 1 minute.

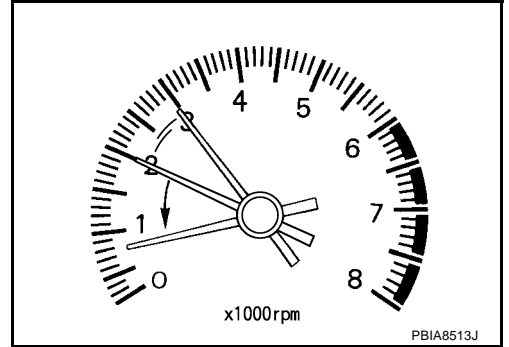

3. Read idle speed in "DATA MONITOR" mode with CONSULT-II.
650 ± 50 rpm (in P or N position)

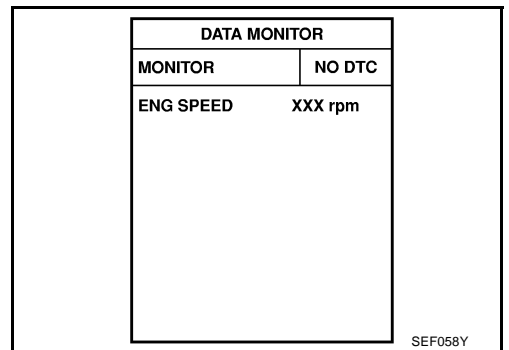

⊗ Without CONSULT-II

1. Run engine at about 2,000 rpm for about 2 minutes under no-load.
2. Rev engine (2,000 to 3,000 rpm) two or three times under no-load, then run engine at idle speed for about 1 minute.
3. Check idle speed.

650 ± 50 rpm (in P or N position)

OK or NG

- OK >> GO TO 9.
NG >> GO TO 4.

4. PERFORM ACCELERATOR PEDAL RELEASED POSITION LEARNING

1. Stop engine.
2. Perform [EC-49, "Accelerator Pedal Released Position Learning"](#) .

>> GO TO 5.

5. PERFORM THROTTLE VALVE CLOSED POSITION LEARNING

Perform [EC-49, "Throttle Valve Closed Position Learning"](#) .

>> GO TO 6.

6. PERFORM IDLE AIR VOLUME LEARNING

Refer to [EC-49, "Idle Air Volume Learning"](#) .

Is Idle Air Volume Learning carried out successfully?

Yes or No

- Yes >> GO TO 7.
 No >> 1. Follow the instruction of Idle Air Volume Learning.
 2. GO TO 4.

7. CHECK TARGET IDLE SPEED AGAIN

 With CONSULT-II

1. Start engine and warm it up to normal operating temperature.
2. Read idle speed in "DATA MONITOR" mode with CONSULT-II.

650 ± 50 rpm (in P or N position)

 Without CONSULT-II

1. Start engine and warm it up to normal operating temperature.
2. Check idle speed.

650 ± 50 rpm (in P or N position)

OK or NG

- OK >> GO TO 10.
 NG >> GO TO 8.

DATA MONITOR	
MONITOR	NO DTC
ENG SPEED	XXX rpm
COOLAN TEMP/S	XXX °C

SEP174Y

8. DETECT MALFUNCTIONING PART

Check the following.

- Check camshaft position sensor (PHASE) and circuit. Refer to [EC-308](#) .
- Check crankshaft position sensor (POS) and circuit. Refer to [EC-302](#) .

OK or NG

- OK >> GO TO 9.
 NG >> 1. Repair or replace.
 2. GO TO 4.

9. CHECK ECM FUNCTION

1. Substitute another known-good ECM to check ECM function. (ECM may be the cause of an incident, but this is a rare case.)
2. Perform initialization of IVIS (NATS) system and registration of IVIS (NATS) ignition key IDs. Refer to [EC-68, "IVIS \(Infiniti Vehicle Immobilizer System — NATS\)"](#) .

>> GO TO 4.

10. CHECK IGNITION TIMING

1. Run engine at idle.
2. Check ignition timing with a timing light.

15 ± 5° BTDC (in P or N position)

OK or NG

- OK >> **INSPECTION END**
 NG >> GO TO 11.

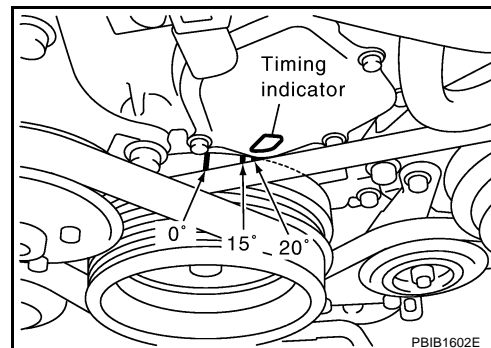

11. PERFORM ACCELERATOR PEDAL RELEASED POSITION LEARNING

1. Stop engine.
2. Perform [EC-49, "Accelerator Pedal Released Position Learning"](#).

>> GO TO 12.

12. PERFORM THROTTLE VALVE CLOSED POSITION LEARNING

Perform [EC-49, "Throttle Valve Closed Position Learning"](#).

>> GO TO 13.

13. PERFORM IDLE AIR VOLUME LEARNING

Refer to [EC-49, "Idle Air Volume Learning"](#).

Is Idle Air Volume Learning carried out successfully?

Yes or No

- Yes >> GO TO 14.
 No >> 1. Follow the instruction of Idle Air Volume Learning.
 2. GO TO 4.

14. CHECK TARGET IDLE SPEED AGAIN

With CONSULT-II

1. Start engine and warm it up to normal operating temperature.
2. Read idle speed in "DATA MONITOR" mode with CONSULT-II.

650 ± 50 rpm (in P or N position)

Without CONSULT-II

1. Start engine and warm it up to normal operating temperature.
2. Check idle speed.

650 ± 50 rpm (in P or N position)

OK or NG

- OK >> GO TO 15.
 NG >> GO TO 17.

DATA MONITOR	
MONITOR	NO DTC
ENG SPEED	XXX rpm
COOLAN TEMP/S	XXX °C

SEF174Y

15. CHECK IGNITION TIMING AGAIN

1. Run engine at idle.
2. Check ignition timing with a timing light.

15 ± 5° BTDC (in P or N position)

OK or NG

- OK >> **INSPECTION END**
 NG >> GO TO 16.

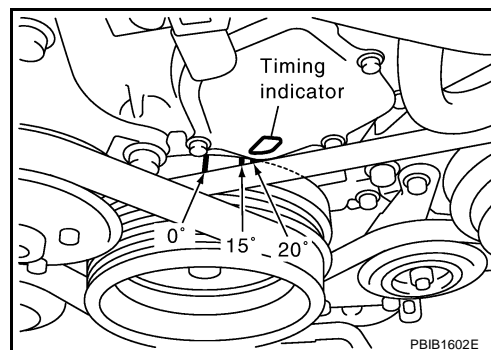

16. CHECK TIMING CHAIN INSTALLATION

Check timing chain installation. Refer to [EM-63, "TIMING CHAIN"](#).

OK or NG

- OK >> GO TO 17.
 NG >> 1. Repair the timing chain installation.
 2. GO TO 4.

17. DETECT MALFUNCTIONING PART

Check the following.

- Check camshaft position sensor (PHASE) and circuit. Refer to [EC-308](#).
- Check crankshaft position sensor (POS) and circuit. Refer to [EC-302](#).

OK or NG

- OK >> GO TO 18.
 NG >> 1. Repair or replace.
 2. GO TO 4.

18. CHECK ECM FUNCTION

1. Substitute another known-good ECM to check ECM function. (ECM may be the cause of an incident, but this is a rare case.)
2. Perform initialization of IVIS (NATS) system and registration of IVIS (NATS) ignition key IDs. Refer to [EC-68, "IVIS \(Infiniti Vehicle Immobilizer System — NATS\)"](#).

>> GO TO 4.

TROUBLE DIAGNOSIS

[VQ35DE]

Symptom Matrix Chart SYSTEM — BASIC ENGINE CONTROL SYSTEM

ABS006KS

		SYMPTOM												Reference page	
		HARD/NO START/RESTART (EXCP. HA)	ENGINE STALL	HESITATION/SURGING/FLAT SPOT	SPARK KNOCK/DETONATION	LACK OF POWER/POOR ACCELERATION	HIGH IDLE/LOW IDLE	ROUGH IDLE/HUNTING	IDLING VIBRATION	SLOW/NO RETURN TO IDLE	OVERHEATS/WATER TEMPERATURE HIGH	EXCESSIVE FUEL CONSUMPTION	EXCESSIVE OIL CONSUMPTION		BATTERY DEAD (UNDER CHARGE)
Warranty symptom code		AA	AB	AC	AD	AE	AF	AG	AH	AJ	AK	AL	AM	HA	
Fuel	Fuel pump circuit	1	1	2	3	2		2	2			3		2	EC-603
	Fuel pressure regulator system	3	3	4	4	4	4	4	4	4		4			EC-51
	Injector circuit	1	1	2	3	2		2	2			2			EC-597
	Evaporative emission system	3	3	4	4	4	4	4	4	4		4			EC-643
Air	Positive crankcase ventilation system	3	3	4	4	4	4	4	4	4		4	1		EC-655
	Incorrect idle speed adjustment						1	1	1	1		1			EC-38
	Electric throttle control actuator	1	1	2	3	3	2	2	2	2		2		2	EC-415 , EC-417
Ignition	Incorrect ignition timing adjustment	3	3	1	1	1		1	1			1			EC-38
	Ignition circuit	1	1	2	2	2		2	2			2			EC-585
Power supply and ground circuit		2	2	3	3	3		3	3		2	3			EC-136
Mass air flow sensor circuit		1			2										EC-165 , EC-173
Engine coolant temperature sensor circuit							3				3				EC-185 , EC-197
Heated oxygen sensor 1 circuit				1	2	3	2		2	2			2		EC-205 , EC-214 , EC-226 , EC-433 , EC-439
Throttle position sensor circuit							2			2					EC-190 , EC-284 , EC-485 , EC-487 , EC-569
Accelerator pedal position sensor circuit				3	2	1									EC-489 , EC-555 , EC-562 , EC-576
Knock sensor circuit				2								3			EC-297
Crankshaft position sensor (POS) circuit		2	2												EC-302
Camshaft position sensor (PHASE) circuit		3	2												EC-308
Vehicle speed signal circuit			2	3		3						3			EC-390
Power steering pressure sensor circuit			2					3	3						EC-396

TROUBLE DIAGNOSIS

[VQ35DE]

	SYMPTOM													Reference page
	HARD/NO START/RESTART (EXCP. HA)	ENGINE STALL	HESITATION/SURGING/FLAT SPOT	SPARK KNOCK/DETONATION	LACK OF POWER/POOR ACCELERATION	HIGH IDLE/LOW IDLE	ROUGH IDLE/HUNTING	IDLING VIBRATION	SLOW/NO RETURN TO IDLE	OVERHEATS/WATER TEMPERATURE HIGH	EXCESSIVE FUEL CONSUMPTION	EXCESSIVE OIL CONSUMPTION	BATTERY DEAD (UNDER CHARGE)	
Warranty symptom code	AA	AB	AC	AD	AE	AF	AG	AH	AJ	AK	AL	AM	HA	
ECM	2	2	3	3	3	3	3	3	3	3	3			EC-401 , EC-404
Intake valve timing control solenoid valve circuit		3	2		1	3	2	2	3		3			EC-408
PNP switch circuit			3		3		3	3			3			EC-545
Refrigerant pressure sensor circuit		2				3			3		4			EC-609
Electrical load signal circuit							3							EC-614
Air conditioner circuit	2	2	3	3	3	3	3	3	3		3		2	ATC-40
ABS actuator and electric unit (control unit)			4											BRC-12

1 - 6: The numbers refer to the order of inspection.
(continued on next page)

SYSTEM — ENGINE MECHANICAL & OTHER

	SYMPTOM													Reference page
	HARD/NO START/RESTART (EXCP. HA)	ENGINE STALL	HESITATION/SURGING/FLAT SPOT	SPARK KNOCK/DETONATION	LACK OF POWER/POOR ACCELERATION	HIGH IDLE/LOW IDLE	ROUGH IDLE/HUNTING	IDLING VIBRATION	SLOW/NO RETURN TO IDLE	OVERHEATS/WATER TEMPERATURE HIGH	EXCESSIVE FUEL CONSUMPTION	EXCESSIVE OIL CONSUMPTION	BATTERY DEAD (UNDER CHARGE)	
Warranty symptom code	AA	AB	AC	AD	AE	AF	AG	AH	AJ	AK	AL	AM	HA	
Fuel	Fuel tank	5												FL-10
	Fuel piping		5	5	5		5	5			5			EM-45
	Vapor lock	5												—
	Valve deposit		5	5	5		5	5			5			—
	Poor fuel (Heavy weight gasoline, Low octane)													

TROUBLE DIAGNOSIS

[VQ35DE]

		SYMPTOM												Reference page	
		HARD/NO START/RESTART (EXCP. HA)	ENGINE STALL	HESITATION/SURGING/FLAT SPOT	SPARK KNOCK/DETONATION	LACK OF POWER/POOR ACCELERATION	HIGH IDLE/LOW IDLE	ROUGH IDLE/HUNTING	IDLING VIBRATION	SLOW/NO RETURN TO IDLE	OVERHEATS/WATER TEMPERATURE HIGH	EXCESSIVE FUEL CONSUMPTION	EXCESSIVE OIL CONSUMPTION		BATTERY DEAD (UNDER CHARGE)
Warranty symptom code		AA	AB	AC	AD	AE	AF	AG	AH	AJ	AK	AL	AM	HA	
Air	Air duct														EM-17
	Air cleaner														EM-17
	Air leakage from air duct (Mass air flow sensor — electric throttle control actuator)	5	5	5		5		5	5			5			EM-17
	Electric throttle control actuator	5			5		5			5					EM-19
	Air leakage from intake manifold/ Collector/Gasket														EM-19 , EM-24
Cranking	Battery	1	1	1		1		1	1					1	SC-4
	Generator circuit														SC-23
	Starter circuit	3										1			SC-10
	Signal plate	6													EM-120
	PNP switch	4													AT-112
Engine	Cylinder head	5	5	5	5	5		5	5			5			EM-98
	Cylinder head gasket										4		3		
	Cylinder block														
	Piston												4		
	Piston ring														
	Connecting rod	6	6	6	6	6		6	6			6			EM-120
	Bearing														
	Crankshaft														
Valve mechanism	Timing chain														EM-63
	Camshaft														EM-82
	Intake valve timing control	5	5	5	5	5		5	5			5		EM-63	
	Intake valve												3		EM-98
	Exhaust valve														
Exhaust	Exhaust manifold/Tube/Muffler/ Gasket	5	5	5	5	5		5	5			5			EM-26 , EX-3
	Three way catalyst														
Lubrication	Oil pan/Oil strainer/Oil pump/Oil filter/ Oil gallery/Oil cooler	5	5	5	5	5		5	5			5			EM-30 , LU-17 , LU-10 , LU-14
	Oil level (Low)/Filthy oil														LU-7

TROUBLE DIAGNOSIS

[VQ35DE]

		SYMPTOM												Reference page		
		HARD/NO START/RESTART (EXCP. HA)	ENGINE STALL	HESITATION/SURGING/FLAT SPOT	SPARK KNOCK/DETONATION	LACK OF POWER/POOR ACCELERATION	HIGH IDLE/LOW IDLE	ROUGH IDLE/HUNTING	IDLING VIBRATION	SLOW/NO RETURN TO IDLE	OVERHEATS/WATER TEMPERATURE HIGH	EXCESSIVE FUEL CONSUMPTION	EXCESSIVE OIL CONSUMPTION		BATTERY DEAD (UNDER CHARGE)	
Warranty symptom code		AA	AB	AC	AD	AE	AF	AG	AH	AJ	AK	AL	AM	HA		
Cooling	Radiator/Hose/Radiator filler cap														CO-14 , CO-17	
	Thermostat									5					CO-26	
	Water pump														CO-22	
	Water gallery	5	5	5	5	5		5	5		4	5			CO-28	
	Cooling fan														5	EC-203
	Coolant level (Low)/Contaminated coolant														5	CO-11
IVIS (Infiniti Vehicle Immobilizer System — NATS)		1	1												EC-68 or BL-206	

1 - 6: The numbers refer to the order of inspection.

A
EC
C
D
E
F
G
H
I
J
K
L
M

Engine Control Component Parts Location

ABS006KT

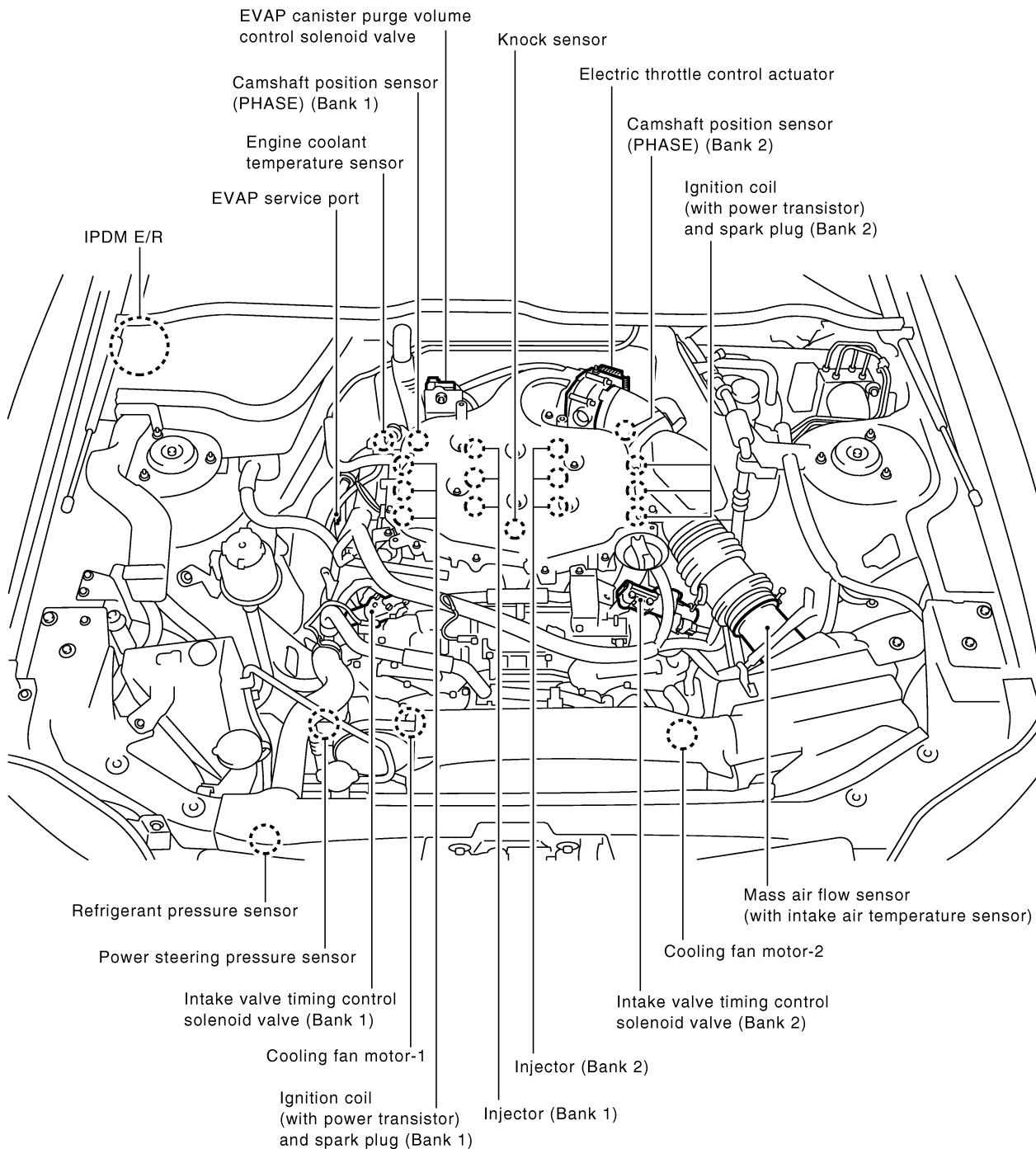

PBIB2002E

A
EC
C
D
E
F
G
H
I
J
K
L
M

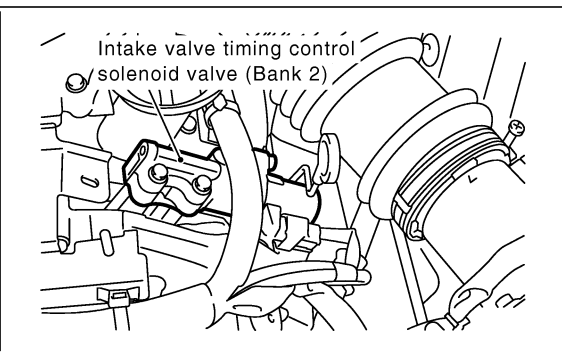
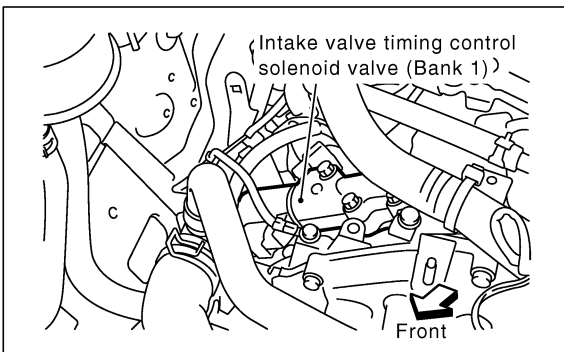
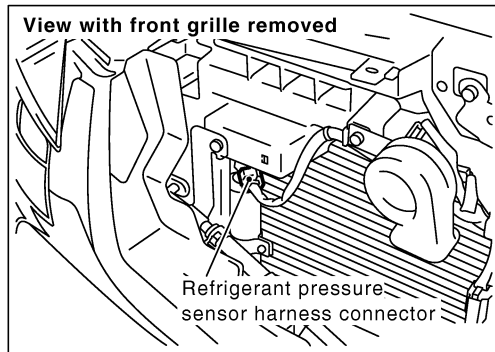
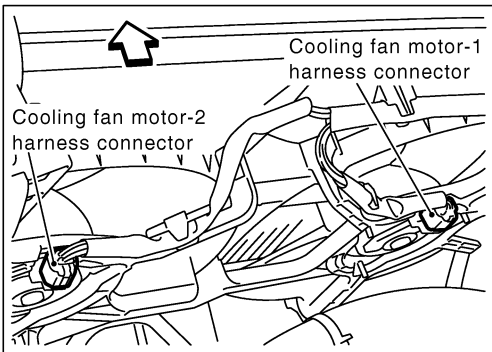
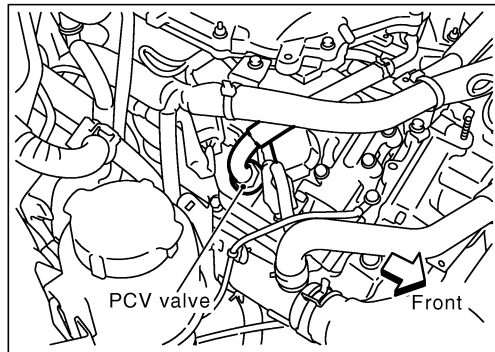
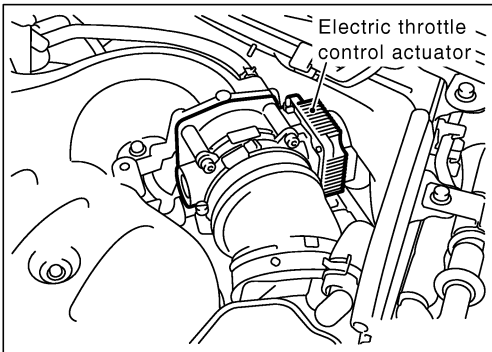
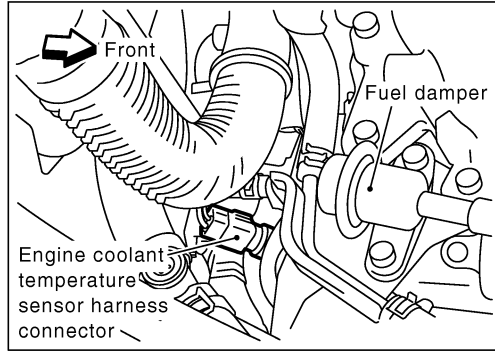
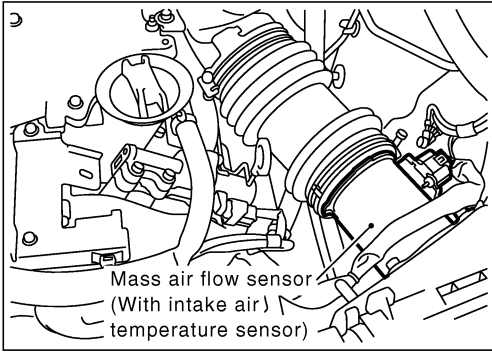

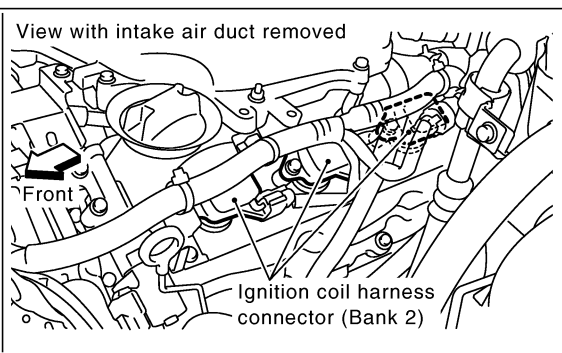
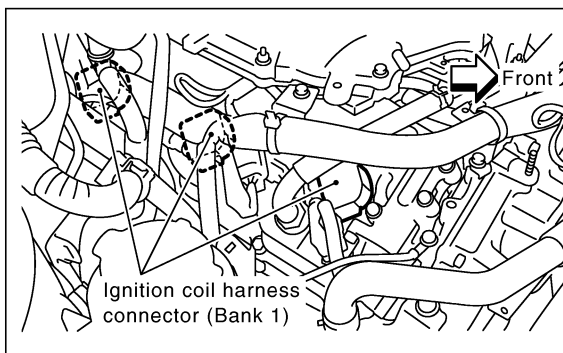
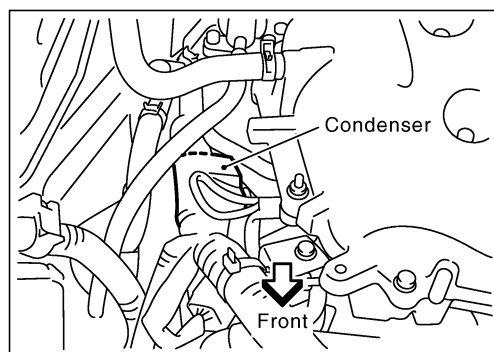
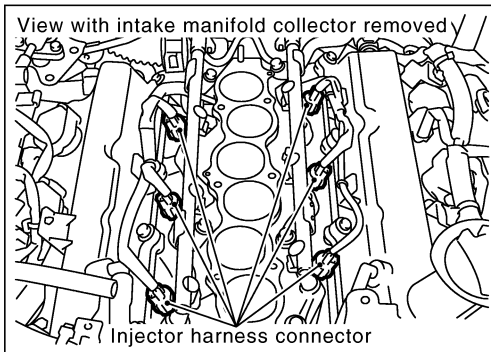
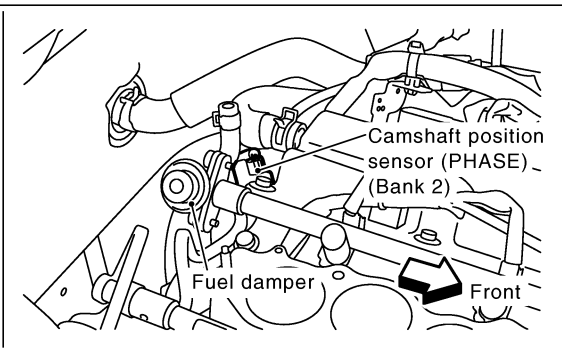
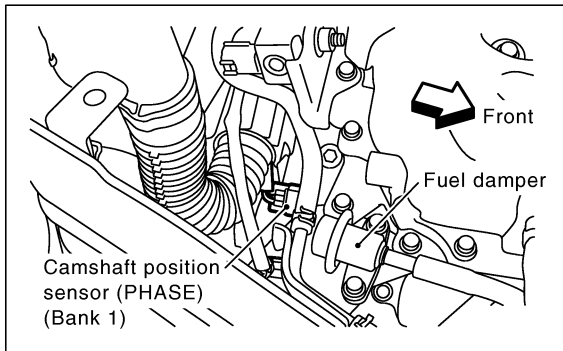
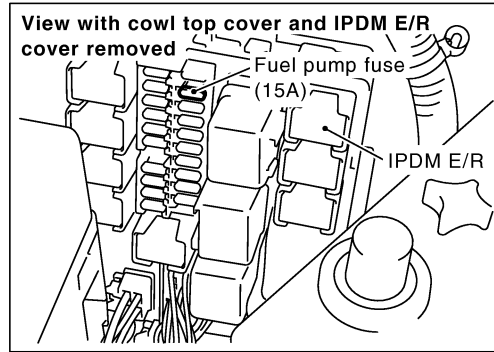
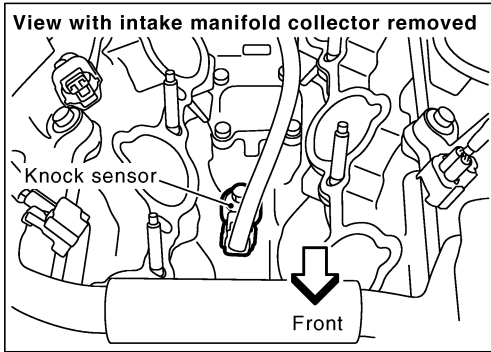

TROUBLE DIAGNOSIS

[VQ35DE]

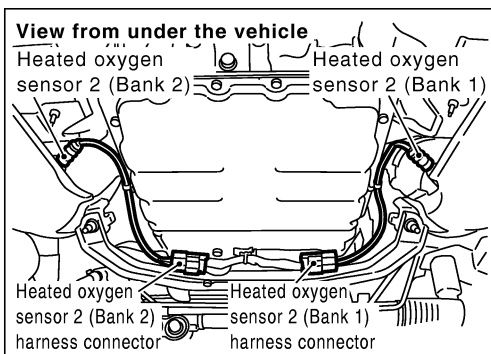
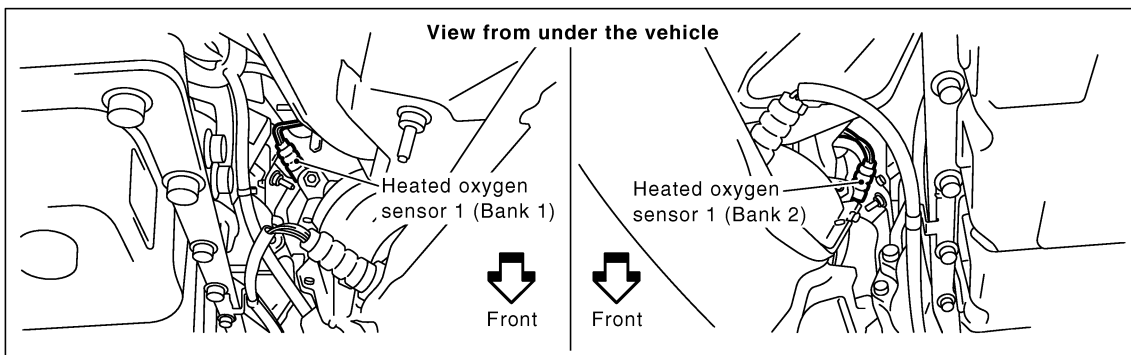
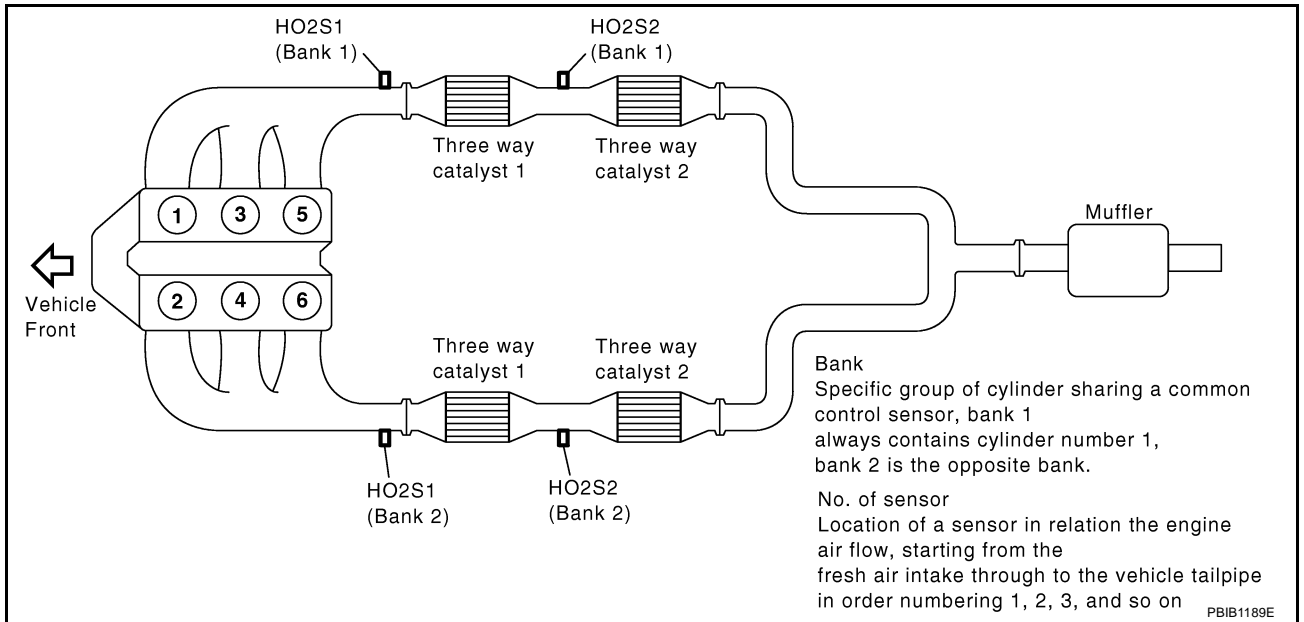

PBIB1617E

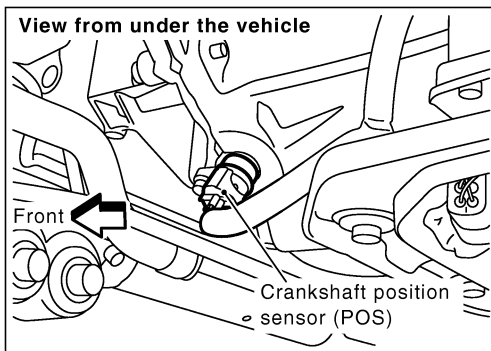
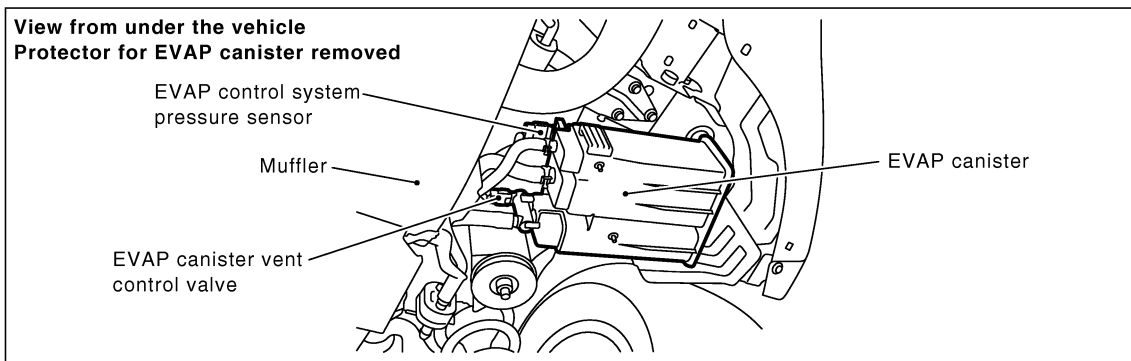
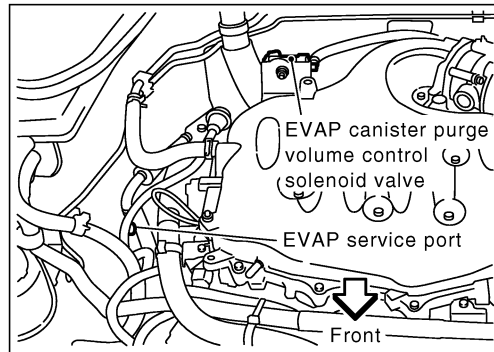
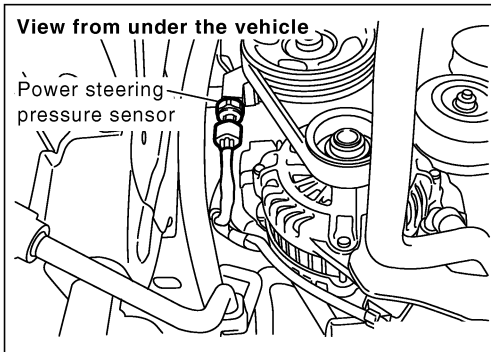

A
EC
C
D
E
F
G
H
I
J
K
L
M

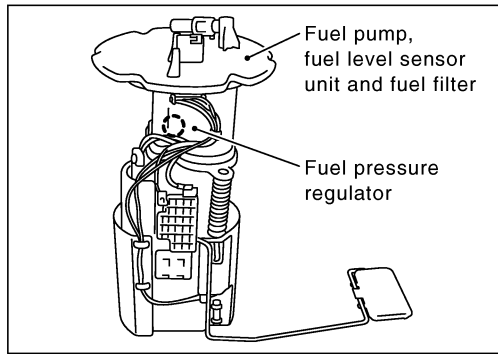
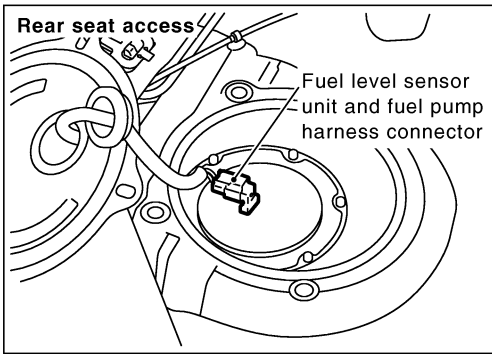
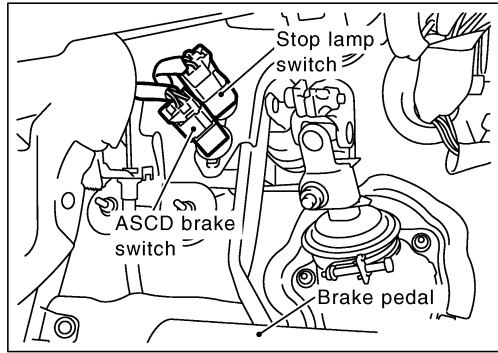
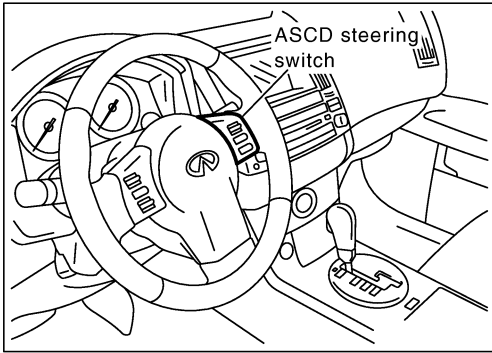
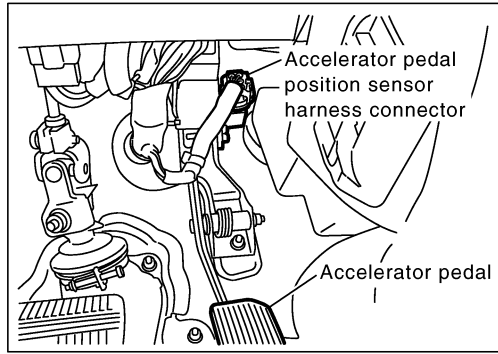
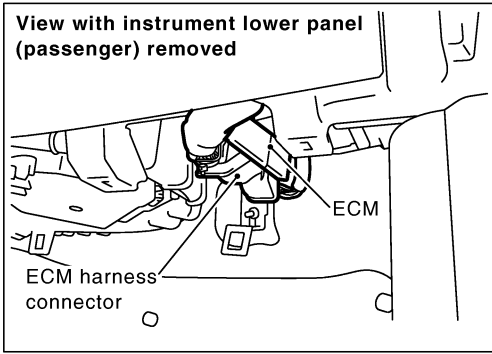

Circuit Diagram

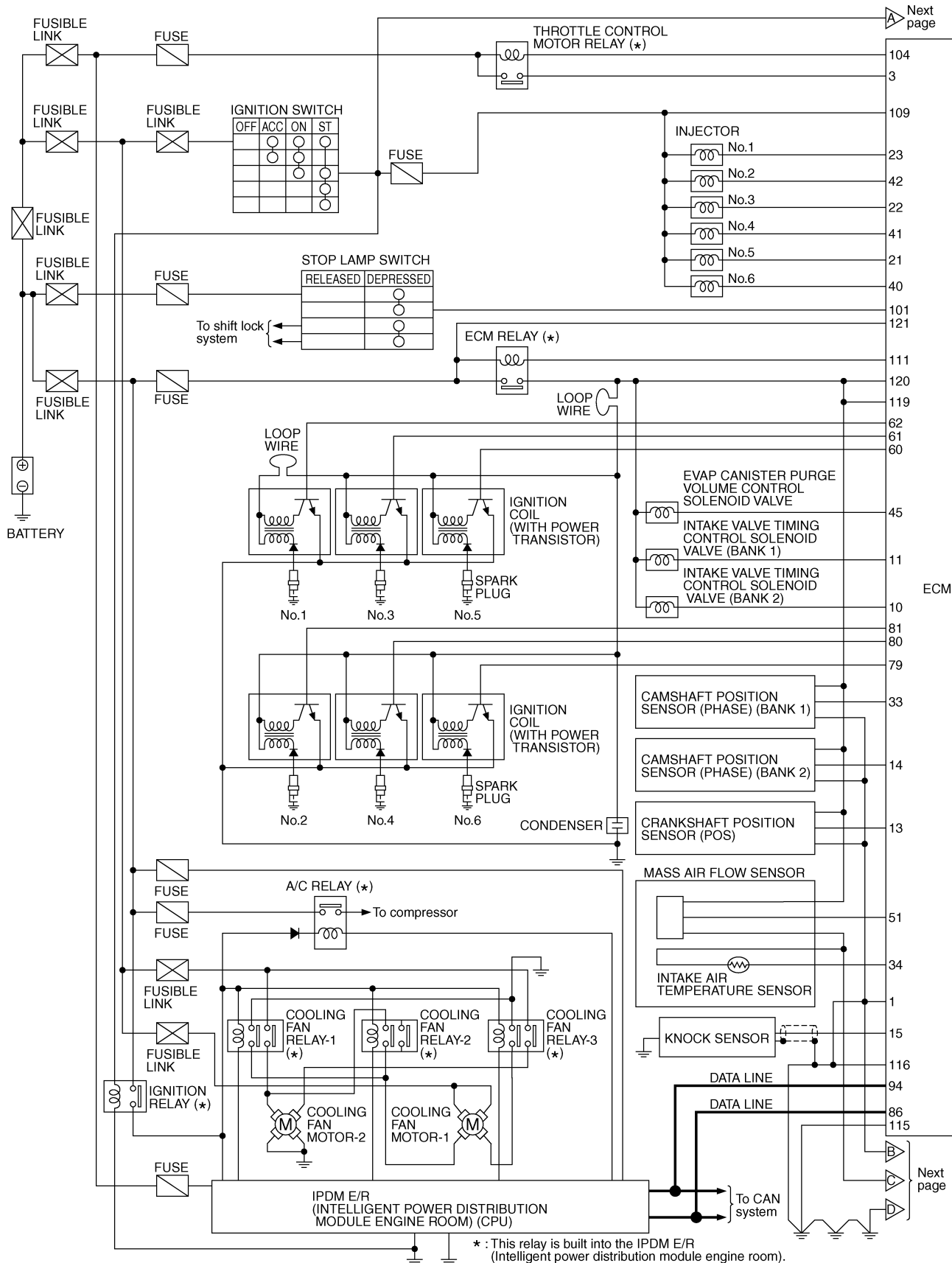

TROUBLE DIAGNOSIS

[VQ35DE]

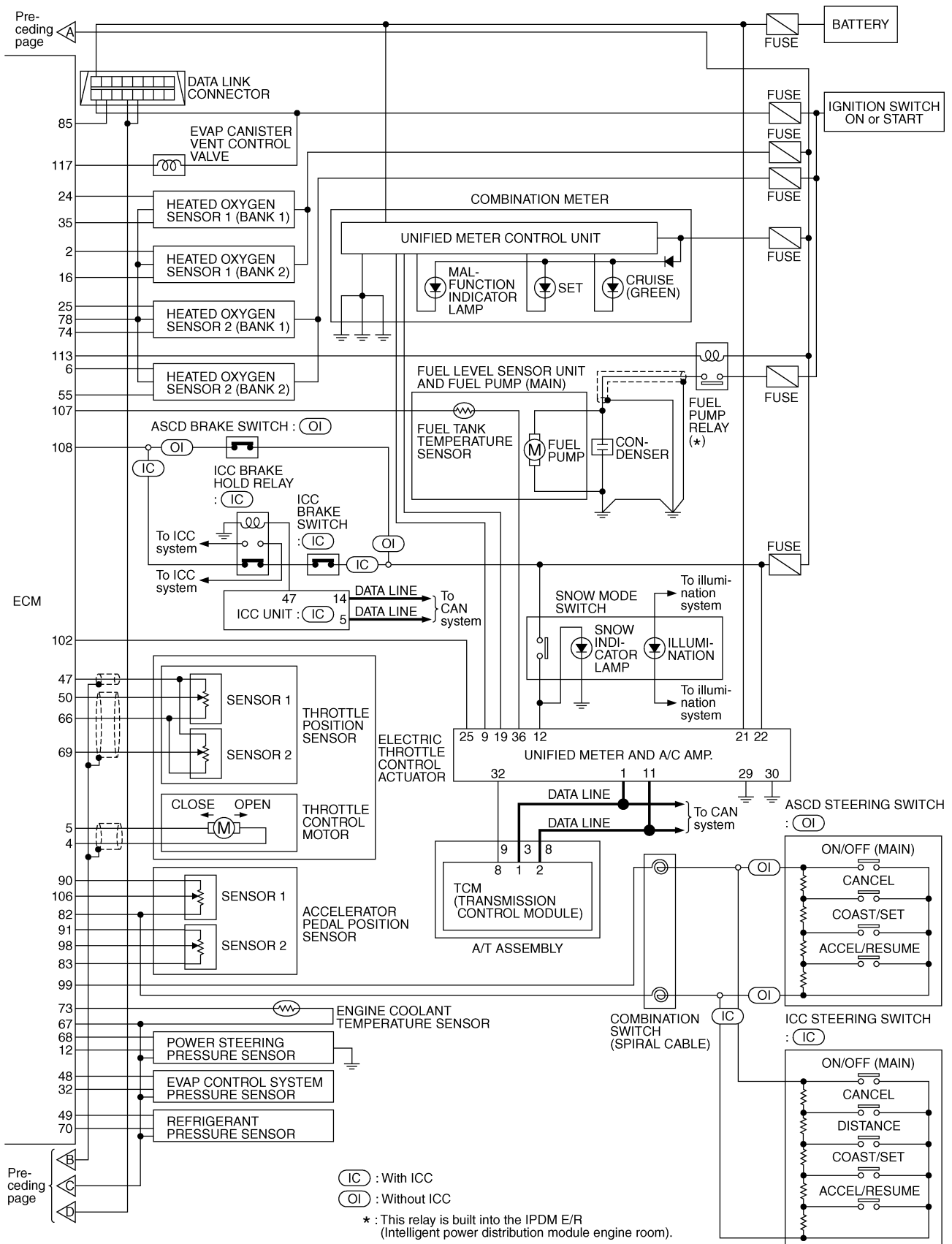

Pre-
ceding
page

ECM

Pre-
ceding
page

A

EC

C

D

E

F

G

H

I

J

K

L

M

TBWM0522E

ECM Harness Connector Terminal Layout

ABS006KV

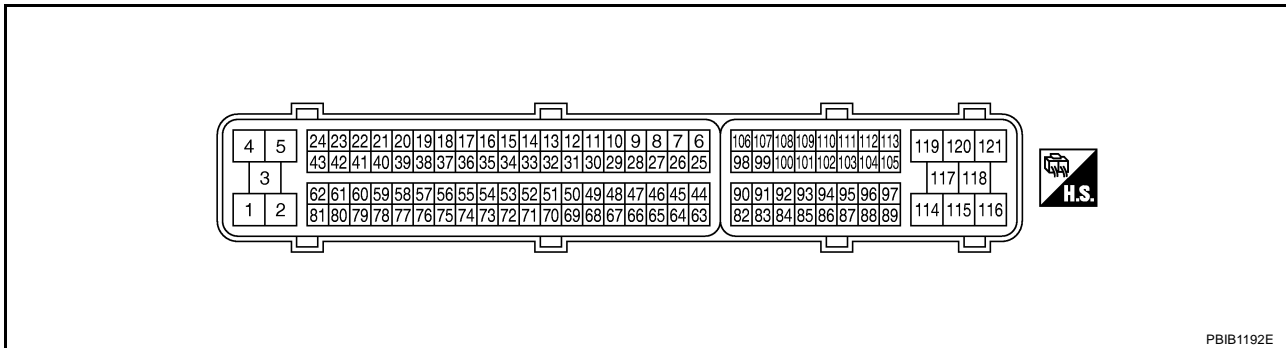

PBIB1192E

ECM Terminals and Reference Value PREPARATION

ABS006KW

1. ECM is located behind the passenger side instrument lower panel. For this inspection, remove passenger side instrument lower panel.
2. Remove ECM harness connector.

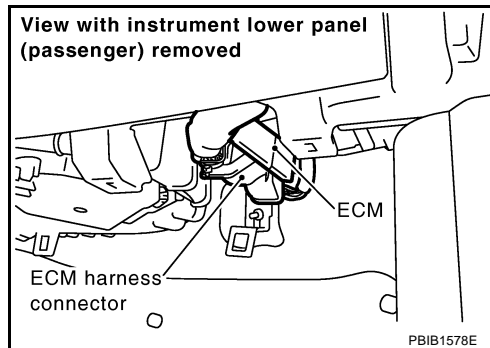

3. When disconnecting ECM harness connector, loosen it with levers as far as they will go as shown in the figure.
4. Connect a break-out box (SST) and Y-cable adapter (SST) between the ECM and ECM harness connector.
 - Use extreme care not to touch 2 pins at one time.
 - Data is for comparison and may not be exact.

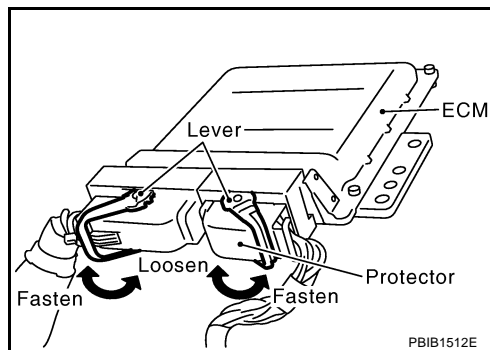

ECM INSPECTION TABLE

Specification data are reference values and are measured between each terminal and ground. Pulse signal is measured by CONSULT-II.



CAUTION:

Do not use ECM ground terminals when measuring input/output voltage. Doing so may result in damage to the ECMs transistor. Use a ground other than ECM terminals, such as the ground.

TER-MINAL NO.	WIRE COLOR	ITEM	CONDITION	DATA (DC Voltage)
1	B	ECM ground	[Engine is running] ● Idle speed	Body ground

TROUBLE DIAGNOSIS

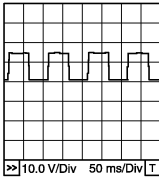

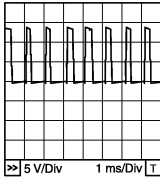
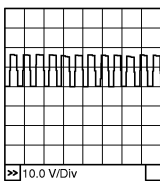

[VQ35DE]

TER-MINAL NO.	WIRE COLOR	ITEM	CONDITION	DATA (DC Voltage)
2	L	Heated oxygen sensor 1 heater (bank 2)	[Engine is running] <ul style="list-style-type: none"> ● Warm-up condition ● Engine speed is below 3,600 rpm 	Approximately 8V★  <small>PBIB0519E</small>
			[Engine is running] <ul style="list-style-type: none"> ● Engine speed is above 3,600 rpm 	BATTERY VOLTAGE (11 - 14V)
3	R	Throttle control motor relay power supply	[Ignition switch: ON]	BATTERY VOLTAGE (11 - 14V)
4	L/W	Throttle control motor (Close)	[Ignition switch: ON] <ul style="list-style-type: none"> ● Engine stopped ● Shift lever: D ● Accelerator pedal: Released 	0 - 14V★  <small>PBIB1104E</small>
5	L/B	Throttle control motor (Open)	[Ignition switch: ON] <ul style="list-style-type: none"> ● Engine stopped ● Shift lever: D ● Accelerator pedal: Fully depressed 	0 - 14V★  <small>PBIB1105E</small>
6	R	Heated oxygen sensor 2 heater (bank 2)	[Engine is running] <ul style="list-style-type: none"> ● Engine speed is below 3,600 rpm after the following conditions are met <ul style="list-style-type: none"> - Engine: after warming up - Keeping the engine speed between 3,500 and 4,000 rpm for 1 minute and at idle for 1 minute under no load 	0 - 1.0V
			[Ignition switch: ON] <ul style="list-style-type: none"> ● Engine stopped [Engine is running] <ul style="list-style-type: none"> ● Engine speed is above 3,600 rpm 	BATTERY VOLTAGE (11 - 14V)
10	OR	Intake valve timing control solenoid valve (bank 2)	[Engine is running] <ul style="list-style-type: none"> ● Warm-up condition ● Idle speed 	BATTERY VOLTAGE (11 - 14V)
			[Engine is running] <ul style="list-style-type: none"> ● Warm-up condition ● When revving engine up to 2,500 rpm quickly 	7 - 12V★  <small>PBIB1790E</small>

A
EC
C
D
E
F
G
H
I
J
K
L
M

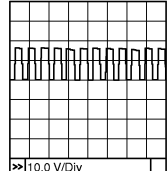
TROUBLE DIAGNOSIS

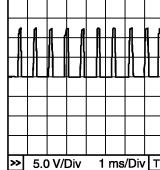
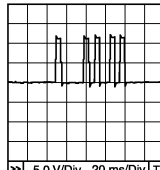
[VQ35DE]

TER-MINAL NO.	WIRE COLOR	ITEM	CONDITION	DATA (DC Voltage)
11	BR	Intake valve timing control solenoid valve (bank 1)	[Engine is running] ● Warm-up condition ● Idle speed	BATTERY VOLTAGE (11 - 14V)
			[Engine is running] ● Warm-up condition ● When revving engine up to 2,500 rpm quickly	7 - 12V★  PBIB1790E
12	R/G	Power steering pressure sensor	[Engine is running] ● Steering wheel is being turned	0.5 - 4.5V
			[Engine is running] ● Steering wheel is not being turned	0.4 - 0.8V
13	Y	Crankshaft position sensor (POS)	[Engine is running] ● Warm-up condition ● Idle speed NOTE: The pulse cycle changes depending on rpm at idle	Approximately 1.6V★  PBIB1041E
			[Engine is running] ● Engine speed is 2,000 rpm	Approximately 1.4V★  PBIB1042E
14	BR	Camshaft position sensor (PHASE) (bank 2)	[Engine is running] ● Warm-up condition ● Idle speed NOTE: The pulse cycle changes depending on rpm at idle	1.0 - 4.0V★  PBIB1039E
			[Engine is running] ● Engine speed is 2,000 rpm	1.0 - 4.0V★  PBIB1040E
15	W	Knock sensor	[Engine is running] ● Idle speed	Approximately 2.5V
16	R/L	Heated oxygen sensor 1 (bank 2)	[Engine is running] ● Warm-up condition ● Engine speed is 2,000 rpm	0 - Approximately 1.0V (Periodically change)

TROUBLE DIAGNOSIS

[VQ35DE]

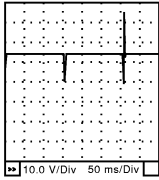
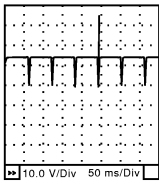
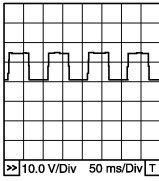
TERMINAL NO.	WIRE COLOR	ITEM	CONDITION	DATA (DC Voltage)
21 22 23	W G R	Injector No. 5 Injector No. 3 Injector No. 1	<p>[Engine is running]</p> <ul style="list-style-type: none"> ● Warm-up condition ● Idle speed <p>NOTE: The pulse cycle changes depending on rpm at idle</p>	<p>BATTERY VOLTAGE (11 - 14V)★</p>  <p style="text-align: right; font-size: small;">SEC984C</p>
			<p>[Engine is running]</p> <ul style="list-style-type: none"> ● Warm-up condition ● Engine speed is 2,000 rpm 	<p>BATTERY VOLTAGE (11 - 14V)★</p>  <p style="text-align: right; font-size: small;">SEC985C</p>
24	L	Heated oxygen sensor 1 heater (bank 1)	<p>[Engine is running]</p> <ul style="list-style-type: none"> ● Warm-up condition ● Engine speed is below 3,600 rpm 	<p>Approximately 8V★</p>  <p style="text-align: right; font-size: small;">PBIB0519E</p>
			<p>[Engine is running]</p> <ul style="list-style-type: none"> ● Engine speed is above 3,600 rpm 	<p>BATTERY VOLTAGE (11 - 14V)</p>
25	P	Heated oxygen sensor 2 heater (bank 1)	<p>[Engine is running]</p> <ul style="list-style-type: none"> ● Engine speed is below 3,600 rpm after the following conditions are met <ul style="list-style-type: none"> - Engine: after warming up - Keeping the engine speed between 3,500 and 4,000 rpm for 1 minute and at idle for 1 minute under no load 	<p>0 - 1.0V</p>
			<p>[Ignition switch: ON]</p> <ul style="list-style-type: none"> ● Engine stopped <p>[Engine is running]</p> <ul style="list-style-type: none"> ● Engine speed is above 3,600 rpm 	<p>BATTERY VOLTAGE (11 - 14V)</p>
32	OR	EVAP control system pressure sensor	<p>[Ignition switch: ON]</p>	<p>Approximately 1.8 - 4.8V</p>

A

EC

C

D

E

F

G

H

I

J

K

L

M

TROUBLE DIAGNOSIS

[VQ35DE]

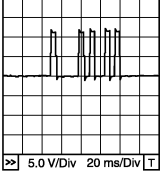
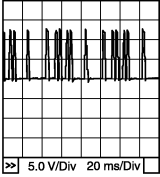
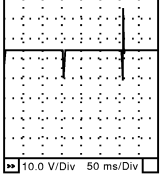
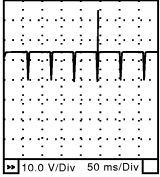
TER-MINAL NO.	WIRE COLOR	ITEM	CONDITION	DATA (DC Voltage)
33	R/L	Camshaft position sensor (PHASE) (bank 1)	<p>[Engine is running]</p> <ul style="list-style-type: none"> ● Warm-up condition ● Idle speed <p>NOTE: The pulse cycle changes depending on rpm at idle</p>	<p>1.0 - 4.0V★</p>  <p style="text-align: right; font-size: small;">PBIB1039E</p>
			<p>[Engine is running]</p> <ul style="list-style-type: none"> ● Engine speed is 2,000 rpm 	<p>1.0 - 4.0V★</p>  <p style="text-align: right; font-size: small;">PBIB1040E</p>
34	OR	Intake air temperature sensor	<p>[Engine is running]</p>	<p>Approximately 0 - 4.8V Output voltage varies with intake air temperature.</p>
35	BR	Heated oxygen sensor 1 (bank 1)	<p>[Engine is running]</p> <ul style="list-style-type: none"> ● Warm-up condition ● Engine speed is 2,000 rpm 	<p>0 - Approximately 1.0V (Periodically change)</p>
40 41 42	LG B P	Injector No. 6 Injector No. 4 Injector No. 2	<p>[Engine is running]</p> <ul style="list-style-type: none"> ● Warm-up condition ● Idle speed <p>NOTE: The pulse cycle changes depending on rpm at idle</p>	<p>BATTERY VOLTAGE (11 - 14V)★</p>  <p style="text-align: right; font-size: small;">SEC984C</p>
			<p>[Engine is running]</p> <ul style="list-style-type: none"> ● Warm-up condition ● Engine speed is 2,000 rpm 	<p>BATTERY VOLTAGE (11 - 14V)★</p>  <p style="text-align: right; font-size: small;">SEC985C</p>

TROUBLE DIAGNOSIS

[VQ35DE]

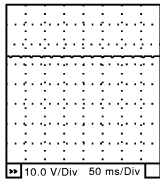
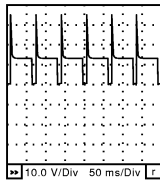
TERMINAL NO.	WIRE COLOR	ITEM	CONDITION	DATA (DC Voltage)
45	GY	EVAP canister purge volume control solenoid valve	[Engine is running] <ul style="list-style-type: none"> ● Idle speed 	BATTERY VOLTAGE (11 - 14V)★  <small>SEC990C</small>
			[Engine is running] <ul style="list-style-type: none"> ● Engine speed is about 2,000 rpm (More than 100 seconds after starting engine) 	BATTERY VOLTAGE (11 - 14V)★  <small>SEC991C</small>
47	L	Sensor power supply (Throttle position sensor)	[Ignition switch: ON]	Approximately 5V
48	LG	Sensor power supply (EVAP control system pressure sensor)	[Ignition switch: ON]	Approximately 5V
49	PU	Sensor power supply (Refrigerant pressure sensor)	[Ignition switch: ON]	Approximately 5V
50	W	Throttle position sensor 1	[Ignition switch: ON] <ul style="list-style-type: none"> ● Engine stopped ● Shift lever: D ● Accelerator pedal: Fully released 	More than 0.36V
			[Ignition switch: ON] <ul style="list-style-type: none"> ● Engine stopped ● Shift lever: D ● Accelerator pedal: Fully depressed 	Less than 4.75V
51	L/W	Mass air flow sensor	[Engine is running] <ul style="list-style-type: none"> ● Warm-up condition ● Idle speed 	0.9 - 1.2V
			[Engine is running] <ul style="list-style-type: none"> ● Warm-up condition ● Engine speed is 2,500 rpm 	1.6 - 1.9V
55	W/R	Heated oxygen sensor 2 (bank 2)	[Engine is running] <ul style="list-style-type: none"> ● Warm-up condition ● Revving engine from idle to 3,000 rpm quickly after the following conditions are met <ul style="list-style-type: none"> - After keeping the engine speed between 3,500 and 4,000 rpm for 1 minute and at idle for 1 minute under no load 	0 - Approximately 1.0V

A
EC
C
D
E
F
G
H
I
J
K
L
M

TROUBLE DIAGNOSIS

[VQ35DE]

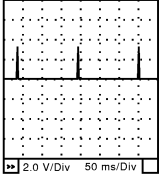
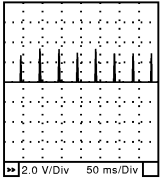
TER-MINAL NO.	WIRE COLOR	ITEM	CONDITION	DATA (DC Voltage)
60 61 62	PU L Y	Ignition signal No. 5 Ignition signal No. 3 Ignition signal No. 1	<p>[Engine is running]</p> <ul style="list-style-type: none"> ● Warm-up condition ● Idle speed <p>NOTE: The pulse cycle changes depending on rpm at idle</p>	<p>0 - 0.2V★</p> 
			<p>[Engine is running]</p> <ul style="list-style-type: none"> ● Warm-up condition ● Engine speed is 2,500 rpm 	<p>0.1 - 0.4V★</p> 
66	B	Sensor ground (Throttle position sensor)	<p>[Engine is running]</p> <ul style="list-style-type: none"> ● Warm-up condition ● Idle speed 	Approximately 0V
67	B/W	Sensor ground	<p>[Engine is running]</p> <ul style="list-style-type: none"> ● Warm-up condition ● Idle speed 	Approximately 0V
68	BR	Sensor power supply (Power steering pressure sensor)	<p>[Ignition switch: ON]</p>	Approximately 5V
69	R	Throttle position sensor 2	<p>[Ignition switch: ON]</p> <ul style="list-style-type: none"> ● Engine stopped ● Shift lever: D ● Accelerator pedal: Fully released 	Less than 4.75V
			<p>[Ignition switch: ON]</p> <ul style="list-style-type: none"> ● Engine stopped ● Shift lever: D ● Accelerator pedal: Fully depressed 	More than 0.36V
70	L/R	Refrigerant pressure sensor	<p>[Engine is running]</p> <ul style="list-style-type: none"> ● Warm-up condition ● Both A/C switch and blower switch are ON (Compressor operates) 	1.0 - 4.0V
73	Y	Engine coolant temperature sensor	<p>[Engine is running]</p>	Approximately 0 - 4.8V Output voltage varies with engine coolant temperature.
74	LG/B	Heated oxygen sensor 2 (bank 1)	<p>[Engine is running]</p> <ul style="list-style-type: none"> ● Warm-up condition ● Revving engine from idle to 3,000 rpm quickly after the following conditions are met <ul style="list-style-type: none"> - After keeping the engine speed between 3,500 and 4,000 rpm for 1 minute and at idle for 1 minute under no load 	0 - Approximately 1.0V
78	B/R	Sensor ground (Heated oxygen sensor)	<p>[Engine is running]</p> <ul style="list-style-type: none"> ● Warm-up condition ● Idle speed 	Approximately 0V

TROUBLE DIAGNOSIS

[VQ35DE]

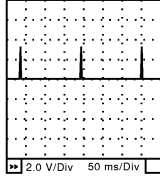
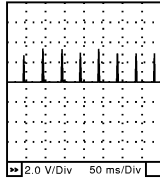
TERMINAL NO.	WIRE COLOR	ITEM	CONDITION	DATA (DC Voltage)
79 80 81	SB GY OR	Ignition signal No. 6 Ignition signal No. 4 Ignition signal No. 2	[Engine is running] <ul style="list-style-type: none"> ● Warm-up condition ● Idle speed NOTE: The pulse cycle changes depending on rpm at idle	0 - 0.2V★ 
			[Engine is running] <ul style="list-style-type: none"> ● Warm-up condition ● Engine speed is 2,500 rpm 	0.1 - 0.4V★ 
82	B/W	Sensor ground (APP sensor 1, ASCD steering switch, ICC steering switch)	[Engine is running] <ul style="list-style-type: none"> ● Warm-up condition ● Idle speed 	Approximately 0V
83	G/OR	Sensor ground (APP sensor 2)	[Engine is running] <ul style="list-style-type: none"> ● Warm-up condition ● Idle speed 	Approximately 0V
85	PU	Data link connector	[Ignition switch: ON] <ul style="list-style-type: none"> ● CONSULT-II or GST is disconnected 	Approximately 5V - Battery voltage (11 - 14V)
86	R	CAN communication line	[Ignition switch: ON]	Approximately 1.1 - 2.3V Output voltage varies with the communication status.
90	L/B	Sensor power supply (APP sensor 1)	[Ignition switch: ON]	Approximately 5V
91	G	Sensor power supply (APP sensor 2)	[Ignition switch: ON]	Approximately 5V
94	L	CAN communication line	[Ignition switch: ON]	Approximately 2.6 - 3.2V Output voltage varies with the communication status.
98	B/P	Accelerator pedal position sensor 2	[Ignition switch: ON] <ul style="list-style-type: none"> ● Engine stopped ● Accelerator pedal: Fully released 	0.15 - 0.60V
			[Ignition switch: ON] <ul style="list-style-type: none"> ● Engine stopped ● Accelerator pedal: Fully depressed 	1.95 - 2.40V

A
EC
C
D
E
F
G
H
I
J
K
L
M

TROUBLE DIAGNOSIS

[VQ35DE]

TER-MINAL NO.	WIRE COLOR	ITEM	CONDITION	DATA (DC Voltage)
99	G/Y	ICC steering switch (models with ICC system)	[Ignition switch: ON] ● ICC steering switch: OFF	Approximately 4.3V
			[Ignition switch: ON] ● ON/OFF(MAIN) switch: Pressed	Approximately 0V
			[Ignition switch: ON] ● CANCEL switch: Pressed	Approximately 1.3V
			[Ignition switch: ON] ● DISTANCE switch: Pressed	Approximately 2.2V
			[Ignition switch: ON] ● COAST/SET switch: Pressed	Approximately 3.0V
			[Ignition switch: ON] ● ACCEL/RESUME switch: Pressed	Approximately 3.7V
99	G/Y	ASCD steering switch (models with ASCD system)	[Ignition switch: ON] ● ASCD steering switch: OFF	Approximately 4.0V
			[Ignition switch: ON] ● ON/OFF(MAIN) switch: Pressed	Approximately 0V
			[Ignition switch: ON] ● CANCEL switch: Pressed	Approximately 1.0V
			[Ignition switch: ON] ● COAST/SET switch: Pressed	Approximately 2.0V
			[Ignition switch: ON] ● ACCEL/RESUME switch: Pressed	Approximately 3.0V
101	P/L	Stop lamp switch	[Ignition switch: OFF] ● Brake pedal: Fully released	Approximately 0V
			[Ignition switch: OFF] ● Brake pedal: Slightly depressed	BATTERY VOLTAGE (11 - 14V)
102	LG/B	PNP switch	[Ignition switch: ON] ● Shift lever: P or N	Approximately 0V
			[Ignition switch: ON] ● Except above position	BATTERY VOLTAGE (11 - 14V)
104	L/OR	Throttle control motor relay	[Ignition switch: OFF]	BATTERY VOLTAGE (11 - 14V)
			[Ignition switch: ON]	0 - 1.0V
106	R/B	Accelerator pedal position sensor 1	[Ignition switch: ON] ● Engine stopped ● Accelerator pedal: Fully released	0.5 - 1.0V
			[Ignition switch: ON] ● Engine stopped ● Accelerator pedal: Fully depressed	3.9 - 4.7V
107	PU/W	Fuel tank temperature sensor	[Engine is running]	Approximately 0 - 4.8V Output voltage varies with fuel tank temperature.
108	SB	ICC brake switch (models with ICC system)	[Ignition switch: ON] ● Brake pedal: Depressed	Approximately 0V
		ASCD brake switch (models with ASCD system)	[Ignition switch: ON] ● Brake pedal: Fully released	BATTERY VOLTAGE (11 - 14V)

TROUBLE DIAGNOSIS

[VQ35DE]

TERMINAL NO.	WIRE COLOR	ITEM	CONDITION	DATA (DC Voltage)
109	W/L	Ignition switch	[Ignition switch: OFF]	0V
			[Ignition switch: ON]	BATTERY VOLTAGE (11 - 14V)
111	W/B	ECM relay (Self shut-off)	[Engine is running] [Ignition switch: OFF] ● For a few seconds after turning ignition switch OFF	0 - 1.5V
			[Ignition switch: OFF] ● More than a few seconds after turning ignition switch OFF	BATTERY VOLTAGE (11 - 14V)
113	GY/R	Fuel pump relay	[Ignition switch: ON] ● For 1 second after turning ignition switch ON	0 - 1.5V
			[Engine is running] [Ignition switch: ON] ● More than 1 second after turning ignition switch ON	BATTERY VOLTAGE (11 - 14V)
115 116	B/R B/W	ECM ground	[Engine is running] ● Idle speed	Body ground
117	R/Y	EVAP canister vent control valve	[Ignition switch: ON]	BATTERY VOLTAGE (11 - 14V)
119 120	R R	Power supply for ECM	[Ignition switch: ON]	BATTERY VOLTAGE (11 - 14V)
121	R/W	Power supply for ECM (Back-up)	[Ignition switch: OFF]	BATTERY VOLTAGE (11 - 14V)

★: Average voltage for pulse signal (Actual pulse signal can be confirmed by oscilloscope.)

CONSULT-II Function FUNCTION

ABS006KX

Diagnostic test mode	Function
Work support	This mode enables a technician to adjust some devices faster and more accurately by following the indications on the CONSULT-II unit.
Self-diagnostic results	Self-diagnostic results such as 1st trip DTC, DTCs and 1st trip freeze frame data or freeze frame data can be read and erased quickly.*1
Data monitor	Input/Output data in the ECM can be read.
Data monitor (SPEC)	Input/Output of the specification for Basic fuel schedule, AFM, A/F feedback control value and the other data monitor items can be read.
CAN diagnostic support monitor	The results of transmit/receive diagnosis of CAN communication can be read.
Active test	Diagnostic Test Mode in which CONSULT-II drives some actuators apart from the ECMs and also shifts some parameters in a specified range.
Function test	This mode is used to inform customers when their vehicle condition requires periodic maintenance.
DTC & SRT confirmation	The status of system monitoring tests and the self-diagnosis status/result can be confirmed.
ECM part number	ECM part number can be read.

*1: The following emission-related diagnostic information is cleared when the ECM memory is erased.

- Diagnostic trouble codes
- 1st trip diagnostic trouble codes
- Freeze frame data
- 1st trip freeze frame data
- System readiness test (SRT) codes

TROUBLE DIAGNOSIS

[VQ35DE]

- Test values
- Others

ENGINE CONTROL COMPONENT PARTS/CONTROL SYSTEMS APPLICATION

Item		DIAGNOSTIC TEST MODE							
		WORK SUP-PORT	SELF-DIAGNOSTIC RESULTS		DATA MONI-TOR	DATA MONI-TOR (SPEC)	ACTIVE TEST	DTC & SRT CONFIRMATION	
			DTC*1	FREEZE FRAME DATA*2				SRT STATUS	DTC WORK SUP-PORT
ENGINE CONTROL COMPONENT PARTS INPUT	Crankshaft position sensor (POS)		×	×	×	×			
	Camshaft position sensor (PHASE)		×	×	×	×			
	Mass air flow sensor		×		×	×			
	Engine coolant temperature sensor		×	×	×	×	×		
	Heated oxygen sensor 1		×		×	×		×	×
	Heated oxygen sensor 2		×		×	×		×	×
	Vehicle speed sensor		×	×	×	×			
	Accelerator pedal position sensor		×		×	×			
	Throttle position sensor		×		×	×			
	Fuel tank temperature sensor		×		×	×	×		
	EVAP control system pressure sensor		×		×	×			
	Intake air temperature sensor		×	×	×	×			
	Knock sensor		×						
	Refrigerant pressure sensor				×	×			
	Closed throttle position switch (accelerator pedal position sensor signal)				×	×			
	Air conditioner switch				×	×			
	Park/neutral position (PNP) switch		×		×	×			
	Stop lamp switch		×		×	×			
	Power steering pressure sensor		×		×	×			
	Battery voltage				×	×			
	Load signal				×	×			
	Fuel level sensor		×		×	×			
	ICC steering switch		×		×	×			
ASCD steering switch		×		×	×				
ICC brake switch		×		×	×				
ASCD brake switch		×		×	×				
Snow mode switch				×	×				

TROUBLE DIAGNOSIS

[VQ35DE]

Item		DIAGNOSTIC TEST MODE							
		WORK SUP-PORT	SELF-DIAGNOSTIC RESULTS		DATA MONI-TOR	DATA MONI-TOR (SPEC)	ACTIVE TEST	DTC & SRT CONFIRMATION	
			DTC*1	FREEZE FRAME DATA*2				SRT STATUS	DTC WORK SUP-PORT
ENGINE CONTROL COMPONENT PARTS	OUTPUT	Fuel injector			×	×	×		
	Power transistor (Ignition timing)				×	×	×		
	Throttle control motor relay		×		×	×			
	Throttle control motor		×						
	EVAP canister purge volume control solenoid valve		×		×	×	×		×
	Air conditioner relay				×	×			
	Fuel pump relay	×			×	×	×		
	Cooling fan relay		×		×	×	×		
	Heated oxygen sensor 1 heater		×		×	×		×	
	Heated oxygen sensor 2 heater		×		×	×		×	
	EVAP canister vent control valve	×	×		×	×	×		
	Intake valve timing control solenoid valve		×		×	×	×		
Calculated load value			×	×	×				

X: Applicable

*1: This item includes 1st trip DTCs.

*2: This mode includes 1st trip freeze frame data or freeze frame data. The items appear on CONSULT-II screen in freeze frame data mode only if a 1st trip DTC or DTC is detected. For details, refer to [EC-113](#).

INSPECTION PROCEDURE

CAUTION:

If CONSULT-II is used with no connection of CONSULT-II CONVERTER, malfunctions might be detected in self-diagnosis depending on control unit which carry out CAN communication.

1. Turn ignition switch OFF.
2. Connect CONSULT-II and CONSULT-II CONVERTER to data link connector, which is located under LH dash panel near the hood opener handle.
3. Turn ignition switch ON.

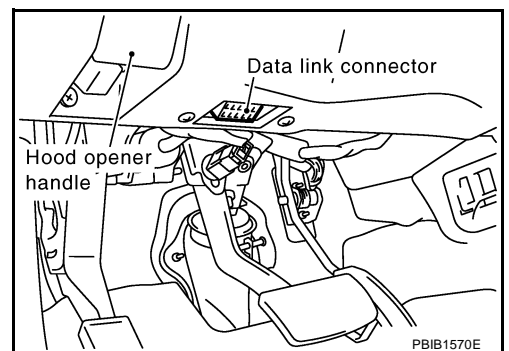

4. Touch "START (NISSAN BASED VHCL)".

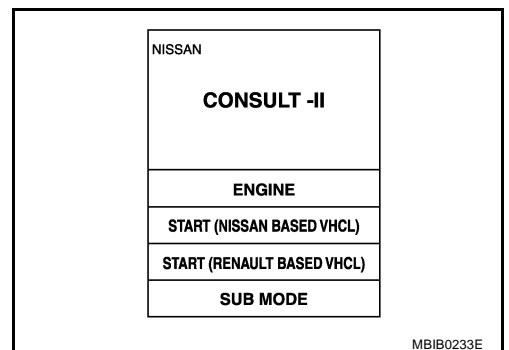

5. Touch "ENGINE".
If "ENGINE" is not indicated, go to [GI-40, "CONSULT-II Data Link Connector \(DLC\) Circuit"](#).

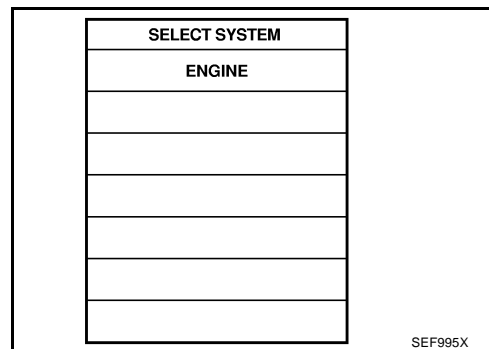

6. Perform each diagnostic test mode according to each service procedure.
For further information, see the CONSULT-II Operation Manual.

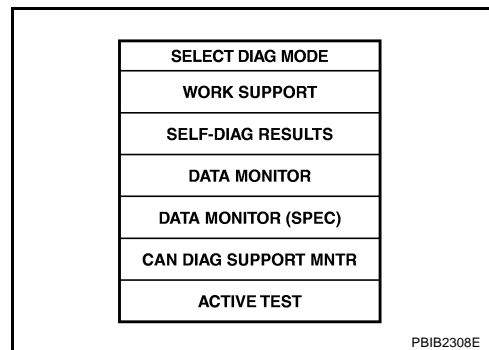

WORK SUPPORT MODE

Work Item

WORK ITEM	CONDITION	USAGE
FUEL PRESSURE RELEASE	<ul style="list-style-type: none"> ● FUEL PUMP WILL STOP BY TOUCHING "START" DURING IDLING. ● CRANK A FEW TIMES AFTER ENGINE STALLS. 	When releasing fuel pressure from fuel line
IDLE AIR VOL LEARN	<ul style="list-style-type: none"> ● THE IDLE AIR VOLUME THAT KEEPS THE ENGINE WITHIN THE SPECIFIED RANGE IS MEMORIZED IN ECM. 	When learning the idle air volume
SELF-LEARNING CONT	<ul style="list-style-type: none"> ● THE COEFFICIENT OF SELF-LEARNING CONTROL MIXTURE RATIO RETURNS TO THE ORIGINAL COEFFICIENT. 	When clearing the coefficient of self-learning control value
EVAP SYSTEM CLOSE	<p>CLOSE THE EVAP CANISTER VENT CONTROL VALVE IN ORDER TO MAKE EVAP SYSTEM CLOSE UNDER THE FOLLOWING CONDITIONS.</p> <ul style="list-style-type: none"> ● IGN SW ON ● ENGINE NOT RUNNING ● AMBIENT TEMPERATURE IS ABOVE 0°C (32°F). ● NO VACUUM AND NO HIGH PRESSURE IN EVAP SYSTEM ● FUEL TANK TEMP. IS MORE THAN 0°C (32°F). ● WITHIN 10 MINUTES AFTER STARTING "EVAP SYSTEM CLOSE" ● WHEN TRYING TO EXECUTE "EVAP SYSTEM CLOSE" UNDER THE CONDITION EXCEPT ABOVE, CONSULT-II WILL DISCONTINUE IT AND DISPLAY APPROPRIATE INSTRUCTION. <p>NOTE: WHEN STARTING ENGINE, CONSULT-II MAY DISPLAY "BATTERY VOLTAGE IS LOW. CHARGE BATTERY", EVEN IN USING CHARGED BATTERY.</p>	When detecting EVAP vapor leak point of EVAP system

TROUBLE DIAGNOSIS

[VQ35DE]

WORK ITEM	CONDITION	USAGE
TARGET IDLE RPM ADJ*	● IDLE CONDITION	When setting target idle speed
TARGET IGN TIM ADJ*	● IDLE CONDITION	When adjusting target ignition timing

*: This function is not necessary in the usual service procedure.

SELF-DIAG RESULTS MODE

Self Diagnostic Item

Regarding items of DTC and 1st trip DTC, refer to [EC-15, "INDEX FOR DTC"](#).

Freeze Frame Data and 1st Trip Freeze Frame Data

Freeze frame data item*1	Description
DIAG TROUBLE CODE [PXXXX]	● The engine control component part/control system has a trouble code, it is displayed as "PXXXX". (Refer to EC-15, "INDEX FOR DTC" .)
FUEL SYS-B1	● "Fuel injection system status" at the moment a malfunction is detected is displayed.
FUEL SYS-B2	● One mode in the following is displayed. "Mode2": Open loop due to detected system malfunction "Mode3": Open loop due to driving conditions (power enrichment, deceleration enrichment) "Mode4": Closed loop - using oxygen sensor(s) as feedback for fuel control "Mode5": Open loop - has not yet satisfied condition to go to closed loop
CAL/LD VALUE [%]	● The calculated load value at the moment a malfunction is detected is displayed.
COOLANT TEMP [°C] or [°F]	● The engine coolant temperature at the moment a malfunction is detected is displayed.
L-FUEL TRM-B1 [%]	● "Long-term fuel trim" at the moment a malfunction is detected is displayed.
L-FUEL TRM-B2 [%]	● The long-term fuel trim indicates much more gradual feedback compensation to the base fuel schedule than short-term fuel trim.
S-FUEL TRM-B1 [%]	● "Short-term fuel trim" at the moment a malfunction is detected is displayed.
S-FUEL TRM-B2 [%]	● The short-term fuel trim indicates dynamic or instantaneous feedback compensation to the base fuel schedule.
ENGINE SPEED [rpm]	● The engine speed at the moment a malfunction is detected is displayed.
VEHICL SPEED [km/h] or [mph]	● The vehicle speed at the moment a malfunction is detected is displayed.
B/FUEL SCHDL [msec]	● The base fuel schedule at the moment a malfunction is detected is displayed.
INT/A TEMP SE [°C] or [°F]	● The intake air temperature at the moment a malfunction is detected is displayed.

*1: The items are the same as those of 1st trip freeze frame data.

TROUBLE DIAGNOSIS

[VQ35DE]

DATA MONITOR MODE

Monitored Item

×: Applicable

Monitored item [Unit]	ECM INPUT SIGNALS	MAIN SIGNALS	Description	Remarks
ENG SPEED [rpm]	×	×	<ul style="list-style-type: none"> Indicates the engine speed computed from the signal of the crankshaft position sensor (POS) and camshaft position sensor (PHASE). 	<ul style="list-style-type: none"> Accuracy becomes poor if engine speed drops below the idle rpm. If the signal is interrupted while the engine is running, an abnormal value may be indicated.
MAS A/F SE-B1 [V]	×	×	<ul style="list-style-type: none"> The signal voltage of the mass air flow sensor is displayed. 	<ul style="list-style-type: none"> When the engine is stopped, a certain value is indicated.
B/FUEL SCHDL [msec]		×	<ul style="list-style-type: none"> Base fuel schedule indicates the fuel injection pulse width programmed into ECM, prior to any learned on board correction. 	
A/F ALPHA-B1 [%]		×	<ul style="list-style-type: none"> The mean value of the air-fuel ratio feedback correction factor per cycle is indicated. 	<ul style="list-style-type: none"> When the engine is stopped, a certain value is indicated. This data also includes the data for the air-fuel ratio learning control.
A/F ALPHA-B2 [%]		×		
COOLAN TEMP/S [°C] or [°F]	×	×	<ul style="list-style-type: none"> The engine coolant temperature (determined by the signal voltage of the engine coolant temperature sensor) is displayed. 	<ul style="list-style-type: none"> When the engine coolant temperature sensor is open or short-circuited, ECM enters fail-safe mode. The engine coolant temperature determined by the ECM is displayed.
HO2S1 (B1) [V]	×	×	<ul style="list-style-type: none"> The signal voltage of the heated oxygen sensor 1 is displayed. 	
HO2S1 (B2) [V]	×			
HO2S2 (B1) [V]	×		<ul style="list-style-type: none"> The signal voltage of the heated oxygen sensor 2 is displayed. 	
HO2S2 (B2) [V]	×			
HO2S1 MNTR (B1) [RICH/LEAN]	×	×	<ul style="list-style-type: none"> Display of heated oxygen sensor 1 signal during air-fuel ratio feedback control: RICH: means the mixture became rich, and control is being affected toward a leaner mixture. LEAN: means the mixture became lean, and control is being affected toward a rich mixture. 	<ul style="list-style-type: none"> After turning ON the ignition switch, RICH is displayed until air-fuel mixture ratio feedback control begins. When the air-fuel ratio feedback is clamped, the value just before the clamping is displayed continuously.
HO2S1 MNTR (B2) [RICH/LEAN]	×			
HO2S2 MNTR (B1) [RICH/LEAN]	×		<ul style="list-style-type: none"> Display of heated oxygen sensor 2 signal: RICH: means the amount of oxygen after three way catalyst is relatively small. LEAN: means the amount of oxygen after three way catalyst is relatively large. 	<ul style="list-style-type: none"> When the engine is stopped, a certain value is indicated.
HO2S2 MNTR (B2) [RICH/LEAN]	×			
VHCL SPEED SE [km/h] or [mph]	×	×	<ul style="list-style-type: none"> The vehicle speed computed from the vehicle speed signal sent from combination meter is displayed. 	
BATTERY VOLT [V]	×	×	<ul style="list-style-type: none"> The power supply voltage of ECM is displayed. 	
ACCEL SEN 1 [V]	×	×	<ul style="list-style-type: none"> The accelerator pedal position sensor signal voltage is displayed. 	<ul style="list-style-type: none"> ACCEL SEN2 signal is converted by ECM internally. Thus, they differs from ECM terminal voltage signal.
ACCEL SEN 2 [V]	×			
THRTL SEN 1 [V]	×	×	<ul style="list-style-type: none"> The throttle position sensor signal voltage is displayed. 	<ul style="list-style-type: none"> THRTL SEN2 signal is converted by ECM internally. Thus, they differs from ECM terminal voltage signal.
THRTL SEN 2 [V]	×			

TROUBLE DIAGNOSIS

[VQ35DE]

Monitored item [Unit]	ECM INPUT SIGNALS	MAIN SIGNALS	Description	Remarks
FUEL T/TEMP SE [°C] or [°F]	×		<ul style="list-style-type: none"> The fuel temperature (determined by the signal voltage of the fuel tank temperature sensor) is displayed. 	
INT/A TEMP SE [°C] or [°F]	×	×	<ul style="list-style-type: none"> The intake air temperature (determined by the signal voltage of the intake air temperature sensor) is indicated. 	
EVAP SYS PRES [V]	×		<ul style="list-style-type: none"> The signal voltage of EVAP control system pressure sensor is displayed. 	
FUEL LEVEL SE [V]	×		<ul style="list-style-type: none"> The signal voltage of the fuel level sensor is displayed. 	
START SIGNAL [ON/OFF]	×	×	<ul style="list-style-type: none"> Indicates start signal status [ON/OFF] computed by the ECM according to the signals of engine speed and battery voltage. 	<ul style="list-style-type: none"> After starting the engine, [OFF] is displayed regardless of the starter signal.
CLSD THL POS [ON/OFF]	×	×	<ul style="list-style-type: none"> Indicates idle position [ON/OFF] computed by ECM according to the accelerator pedal position sensor signal. 	
AIR COND SIG [ON/OFF]	×	×	<ul style="list-style-type: none"> Indicates [ON/OFF] condition of the air conditioner switch as determined by the air conditioner signal. 	
P/N POSI SW [ON/OFF]	×	×	<ul style="list-style-type: none"> Indicates [ON/OFF] condition from the park/neutral position (PNP) switch signal. 	
PW/ST SIGNAL [ON/OFF]	×	×	<ul style="list-style-type: none"> [ON/OFF] condition of the power steering system (determined by the signal voltage of the power steering pressure sensor signal) is indicated. 	
LOAD SIGNAL [ON/OFF]	×	×	<ul style="list-style-type: none"> Indicates [ON/OFF] condition from the electrical load signal. <p>ON: Rear window defogger switch is ON and/or lighting switch is in 2nd position. OFF: Both rear window defogger switch and lighting switch are OFF.</p>	
SNOW MODE SW [ON/OFF]			<ul style="list-style-type: none"> Indicates [ON/OFF] condition from the snow mode switch signal. 	
IGNITION SW [ON/OFF]	×		<ul style="list-style-type: none"> Indicates [ON/OFF] condition from ignition switch signal. 	
HEATER FAN SW [ON/OFF]	×		<ul style="list-style-type: none"> Indicates [ON/OFF] condition from the heater fan switch signal. 	
BRAKE SW [ON/OFF]			<ul style="list-style-type: none"> Indicates [ON/OFF] condition from the stop lamp switch signal. 	
INJ PULSE-B1 [msec]		×	<ul style="list-style-type: none"> Indicates the actual fuel injection pulse width compensated by ECM according to the input signals. 	<ul style="list-style-type: none"> When the engine is stopped, a certain computed value is indicated.
INJ PULSE-B2 [msec]				
IGN TIMING [BTDC]		×	<ul style="list-style-type: none"> Indicates the ignition timing computed by ECM according to the input signals. 	<ul style="list-style-type: none"> When the engine is stopped, a certain value is indicated.
CAL/LD VALUE [%]			<ul style="list-style-type: none"> Calculated load value indicates the value of the current air flow divided by peak air flow. 	
MASS AIRFLOW [g·m/s]			<ul style="list-style-type: none"> Indicates the mass air flow computed by ECM according to the signal voltage of the mass air flow sensor. 	

TROUBLE DIAGNOSIS

[VQ35DE]

Monitored item [Unit]	ECM INPUT SIG- NALS	MAIN SIG- NALS	Description	Remarks
PURG VOL C/V [%]			<ul style="list-style-type: none"> Indicates the EVAP canister purge volume control solenoid valve control value computed by the ECM according to the input signals. The opening becomes larger as the value increases. 	
INT/V TIM (B1) [°CA]			<ul style="list-style-type: none"> Indicates [°CA] of intake camshaft advanced angle. 	
INT/V TIM (B2) [°CA]				
INT/V SOL (B1) [%]			<ul style="list-style-type: none"> The control condition of the intake valve timing control solenoid valve (determined by ECM according to the input signals) is indicated. The advance angle becomes larger as the value increases. 	
INT/V SOL (B2) [%]				
AIR COND RLY [ON/OFF]		×	<ul style="list-style-type: none"> The air conditioner relay control condition (determined by ECM according to the input signals) is indicated. 	
FUEL PUMP RLY [ON/OFF]		×	<ul style="list-style-type: none"> Indicates the fuel pump relay control condition determined by ECM according to the input signals. 	
VENT CONT/V [ON/OFF]			<ul style="list-style-type: none"> The control condition of the EVAP canister vent control valve (determined by ECM according to the input signals) is indicated. ON: Closed OFF: Open 	
THRTL RELAY [ON/OFF]			<ul style="list-style-type: none"> Indicates the throttle control motor relay control condition determined by the ECM according to the input signals. 	
COOLING FAN [HI/MID/LOW/OFF]			<ul style="list-style-type: none"> The control condition of the cooling fan (determined by ECM according to the input signals) is indicated. HI: High speed operation MID: Middle speed operation LOW: Low speed operation OFF: Stop 	
HO2S1 HTR (B1) [ON/OFF]			<ul style="list-style-type: none"> Indicates [ON/OFF] condition of heated oxygen sensor 1 heater determined by ECM according to the input signals. 	
HO2S1 HTR (B2) [ON/OFF]				
HO2S2 HTR (B1) [ON/OFF]			<ul style="list-style-type: none"> Indicates [ON/OFF] condition of heated oxygen sensor 2 heater determined by ECM according to the input signals. 	
HO2S2 HTR (B2) [ON/OFF]				
I/P PULLY SPD [rpm]			<ul style="list-style-type: none"> Indicates the engine speed computed from the turbine revolution sensor signal. 	
VEHICLE SPEED [km/h] or [MPH]			<ul style="list-style-type: none"> Indicates the vehicle speed computed from the revolution sensor signal. 	
IDL A/V LEARN [YET/CMPLT]			<ul style="list-style-type: none"> Display the condition of idle air volume learning YET: Idle air volume learning has not been performed yet. CMPLT: Idle air volume learning has already been performed successfully. 	

TROUBLE DIAGNOSIS

[VQ35DE]

Monitored item [Unit]	ECM INPUT SIG- NALS	MAIN SIG- NALS	Description	Remarks	A
TRVL AFTER MIL [km] or [mile]			<ul style="list-style-type: none"> Distance traveled while MIL is activated. 		EC
O2SEN HTR DTY [%]			<ul style="list-style-type: none"> Indicates the heated oxygen sensor 1 heater control value computed by the ECM according to the input signals. 		C
AC PRESS SEN [V]			<ul style="list-style-type: none"> The signal voltage from the refrigerant pressure sensor is displayed. 		D
VHCL SPEED SE [km/h] or [mph]			<ul style="list-style-type: none"> The vehicle speed computed from the vehicle speed signal sent from TCM is displayed. 		E
SET VHCL SPD [km/h] or [mph]			<ul style="list-style-type: none"> The preset vehicle speed is displayed. 		F
MAIN SW [ON/OFF]			<ul style="list-style-type: none"> Indicates [ON/OFF] condition from ON/OFF(MAIN) switch signal. 		G
CANCEL SW [ON/OFF]			<ul style="list-style-type: none"> Indicates [ON/OFF] condition from CANCEL switch signal. 		H
RESUME/ACC SW [ON/OFF]			<ul style="list-style-type: none"> Indicates [ON/OFF] condition from ACCEL/RESUME switch signal. 		I
SET SW [ON/OFF]			<ul style="list-style-type: none"> Indicates [ON/OFF] condition from COAST/SET switch signal. 		J
BRAKE SW1 SW [ON/OFF]			<ul style="list-style-type: none"> Indicates [ON/OFF] condition from ASCD brake switch signal. 		K
BRAKE SW2 SW [ON/OFF]			<ul style="list-style-type: none"> Indicates [ON/OFF] condition of stop lamp switch signal. 		L
VHCL SPD CUT [NON/CUT]			<ul style="list-style-type: none"> Indicates the vehicle cruise condition. NON: Vehicle speed is maintained at the ASCD set speed. CUT: Vehicle speed increased to excessively high compared with the ASCD set speed, and ASCD operation is cut off. 		M
LO SPEED CUT [NON/CUT]			<ul style="list-style-type: none"> Indicates the vehicle cruise condition. NON: Vehicle speed is maintained at the ASCD set speed. CUT: Vehicle speed decreased to excessively low compared with the ASCD set speed, and ASCD operation is cut off. 		
AT OD MONITOR [ON/OFF]			<ul style="list-style-type: none"> Indicates [ON/OFF] condition of A/T O/D according to the input signal from the TCM. 		
AT OD CANCEL [ON/OFF]			<ul style="list-style-type: none"> Indicates [ON/OFF] condition of A/T O/D cancel signal sent from the TCM. 		
CRUISE LAMP [ON/OFF]			<ul style="list-style-type: none"> Indicates [ON/OFF] condition of CRUISE lamp determined by the ECM according to the input signals. 		
SET LAMP [ON/OFF]			<ul style="list-style-type: none"> Indicates [ON/OFF] condition of SET lamp determined by the ECM according to the input signals. 		

TROUBLE DIAGNOSIS

[VQ35DE]

Monitored item [Unit]	ECM INPUT SIGNALS	MAIN SIGNALS	Description	Remarks
Voltage [V]			<ul style="list-style-type: none"> ● Voltage, frequency, duty cycle or pulse width measured by the probe. 	<ul style="list-style-type: none"> ● Only # is displayed if item is unable to be measured. ● Figures with #s are temporary ones. They are the same figures as an actual piece of data which was just previously measured.
Frequency [msec], [Hz] or [%]				
DUTY-HI				
DUTY-LOW				
PLS WIDTH-HI				
PLS WIDTH-LOW				

NOTE:

Any monitored item that does not match the vehicle being diagnosed is deleted from the display automatically.

DATA MONITOR (SPEC) MODE

Monitored Item

Monitored item [Unit]	ECM input signals	Main signals	Description	Remarks
ENG SPEED [rpm]	×	×	<ul style="list-style-type: none"> ● Indicates the engine speed computed from the signal of the crankshaft position sensor (POS) and camshaft position sensor (PHASE). 	
MAS A/F SE-B1 [V]	×	×	<ul style="list-style-type: none"> ● The signal voltage of the mass air flow sensor specification is displayed. 	<ul style="list-style-type: none"> ● When engine is running specification range is indicated.
B/FUEL SCHDL [msec]		×	<ul style="list-style-type: none"> ● Base fuel schedule indicates the fuel injection pulse width programmed into ECM, prior to any learned on board correction. 	<ul style="list-style-type: none"> ● When engine is running specification range is indicated.
A/F ALPHA-B1 [%] A/F ALPHA-B2 [%]		×	<ul style="list-style-type: none"> ● The mean value of the air-fuel ratio feedback correction factor per cycle is indicated. 	<ul style="list-style-type: none"> ● When engine is running specification range is indicated. ● This data also includes the data for the air-fuel ratio learning control.

NOTE:

Any monitored item that does not match the vehicle being diagnosed is deleted from the display automatically.

ACTIVE TEST MODE

Test Item

TEST ITEM	CONDITION	JUDGEMENT	CHECK ITEM (REMEDY)
FUEL INJECTION	<ul style="list-style-type: none"> ● Engine: Return to the original trouble condition ● Change the amount of fuel injection using CONSULT-II. 	If trouble symptom disappears, see CHECK ITEM.	<ul style="list-style-type: none"> ● Harness and connectors ● Fuel injector ● Heated oxygen sensor 1
IGNITION TIMING	<ul style="list-style-type: none"> ● Engine: Return to the original trouble condition ● Timing light: Set ● Retard the ignition timing using CONSULT-II. 	If trouble symptom disappears, see CHECK ITEM.	<ul style="list-style-type: none"> ● Perform Idle Air Volume Learning.
POWER BALANCE	<ul style="list-style-type: none"> ● Engine: After warming up, idle the engine. ● A/C switch: OFF ● Shift lever: P or N ● Cut off each injector signal one at a time using CONSULT-II. 	Engine runs rough or dies.	<ul style="list-style-type: none"> ● Harness and connectors ● Compression ● Fuel injector ● Power transistor ● Spark plug ● Ignition coil

TROUBLE DIAGNOSIS

[VQ35DE]

TEST ITEM	CONDITION	JUDGEMENT	CHECK ITEM (REMEDY)
COOLING FAN*	<ul style="list-style-type: none"> ● Ignition switch: ON ● Turn the cooling fan HI, MID, LOW and OFF using CONSULT-II. 	Cooling fan moves and stops.	<ul style="list-style-type: none"> ● Harness and connectors ● Cooling fan motor ● IPDM E/R
ENG COOLANT TEMP	<ul style="list-style-type: none"> ● Engine: Return to the original trouble condition ● Change the engine coolant temperature using CONSULT-II. 	If trouble symptom disappears, see CHECK ITEM.	<ul style="list-style-type: none"> ● Harness and connectors ● Engine coolant temperature sensor ● Fuel injector
FUEL PUMP RELAY	<ul style="list-style-type: none"> ● Ignition switch: ON (Engine stopped) ● Turn the fuel pump relay ON and OFF using CONSULT-II and listen to operating sound. 	Fuel pump relay makes the operating sound.	<ul style="list-style-type: none"> ● Harness and connectors ● Fuel pump relay
PURG VOL CONT/V	<ul style="list-style-type: none"> ● Engine: After warming up, run engine at 1,500 rpm. ● Change the EVAP canister purge volume control solenoid valve opening percent using CONSULT-II. 	Engine speed changes according to the opening percent.	<ul style="list-style-type: none"> ● Harness and connectors ● Solenoid valve
FUEL/T TEMP SEN	<ul style="list-style-type: none"> ● Change the fuel tank temperature using CONSULT-II. 		
VENT CONTROL/V	<ul style="list-style-type: none"> ● Ignition switch: ON (Engine stopped) ● Turn solenoid valve ON and OFF with the CONSULT-II and listen to operating sound. 	Solenoid valve makes an operating sound.	<ul style="list-style-type: none"> ● Harness and connectors ● Solenoid valve
V/T ASSIGN ANGLE	<ul style="list-style-type: none"> ● Engine: Return to the original trouble condition ● Change intake valve timing using CONSULT-II. 	If trouble symptom disappears, see CHECK ITEM.	<ul style="list-style-type: none"> ● Harness and connectors ● Intake valve timing control solenoid valve

*: Leaving cooling fan OFF with CONSULT-II while engine is running may cause the engine to overheat.

DTC & SRT CONFIRMATION MODE

SRT STATUS Mode

For details, refer to [EC-59, "SYSTEM READINESS TEST \(SRT\) CODE"](#) .

SRT Work Support Mode

This mode enables a technician to drive a vehicle to set the SRT while monitoring the SRT status.

TROUBLE DIAGNOSIS

[VQ35DE]

DTC Work Support Mode

Test mode	Test item	Condition	Reference page
EVAPORATIVE SYSTEM	PURG FLOW P0441	Refer to corresponding trouble diagnosis for DTC.	EC-321
	EVP SML LEAK P0442/P1442*		EC-326
	EVAP V/S LEAK P0456/P1456*		EC-374
	PURG VOL CN/V P1444		EC-494
HO2S1	HO2S1 (B1) P0133		EC-214
	HO2S1 (B1) P0134		EC-226
	HO2S1 (B1) P1143		EC-433
	HO2S1 (B1) P1144		EC-439
	HO2S1 (B2) P0153		EC-214
	HO2S1 (B2) P0154		EC-226
	HO2S1 (B2) P1163		EC-433
	HO2S1 (B2) P1164		EC-439
HO2S2	HO2S2 (B1) P0139		EC-245
	HO2S2 (B1) P1146		EC-446
	HO2S2 (B1) P1147		EC-457
	HO2S2 (B2) P0159	EC-245	
	HO2S2 (B2) P1166	EC-446	
	HO2S2 (B2) P1167	EC-457	

*: DTC P1442 and P1456 does not apply to S50 models but appears in DTC Work Support Mode screens.

REAL TIME DIAGNOSIS IN DATA MONITOR MODE (RECORDING VEHICLE DATA)

Description

CONSULT-II has two kinds of triggers and they can be selected by touching "SETTING" in "DATA MONITOR" mode.

1. "AUTO TRIG" (Automatic trigger):

- The malfunction will be identified on the CONSULT-II screen in real time.

In other words, DTC/1st trip DTC and malfunction item will be displayed if the malfunction is detected by ECM.

At the moment a malfunction is detected by ECM, "MONITOR" in "DATA MONITOR" screen is changed to "Recording Data... xx%" as shown at right, and the data after the malfunction detection is recorded. Then when the percentage reached 100%, "REAL-TIME DIAG" screen is displayed. If "STOP" is touched on the screen during "Recording Data... xx%", "REAL-TIME DIAG" screen is also displayed.

The recording time after the malfunction detection and the recording speed can be changed by "TRIGGER POINT" and "Recording Speed". Refer to CONSULT-II OPERATION MANUAL.

2. "MANU TRIG" (Manual trigger):

- DTC/1st trip DTC and malfunction item will not be displayed automatically on CONSULT-II screen even though a malfunction is detected by ECM. DATA MONITOR can be performed continuously even though a malfunction is detected.

DATA MONITOR	
Recording Data...11%	NO DTC
ENG SPEED	XXX rpm
MAS A/F SE-B1	XXX V
COOLAN TEMP/S	XXX °C
HO2S1 (B1)	XXX V
VHCL SPEED SE	XXX km/h

SEF705Y

SET RECORDING CONDITION
AUTO TRIG
MANU TRIG
TRIGGER POINT
<div style="display: flex; justify-content: space-between; width: 100%;"> 0% 20% 40% 60% 80% 100% </div>
RECORDING SPEED
<div style="display: flex; justify-content: space-between; width: 100%;"> MIN MAX </div> <div style="background-color: black; width: 100%; height: 15px; margin-top: 5px;"></div>
/64 /32 /16 /8 /4 /2 FULL

SEF707X

A
 EC
 C
 D
 E
 F
 G
 H
 I
 J
 K
 L
 M

Operation

1. "AUTO TRIG"

- While trying to detect the DTC/1st trip DTC by performing the DTC Confirmation Procedure, be sure to select to "DATA MONITOR (AUTO TRIG)" mode. You can confirm the malfunction at the moment it is detected.
- While narrowing down the possible causes, CONSULT-II should be set in "DATA MONITOR (AUTO TRIG)" mode, especially in case the incident is intermittent. When you are inspecting the circuit by gently shaking (or twisting) the suspicious connectors, components and harness in the DTC Confirmation Procedure, the moment a malfunction is found the DTC/1st trip DTC will be displayed. (Refer to "INCIDENT SIMULATION TESTS" in [GI-27, "How to Perform Efficient Diagnosis for an Electrical Incident"](#) .)

2. "MANU TRIG"

- If the malfunction is displayed as soon as "DATA MONITOR" is selected, reset CONSULT-II to "MANU TRIG". By selecting "MANU TRIG" you can monitor and store the data. The data can be utilized for further diagnosis, such as a comparison with the value for the normal operating condition.

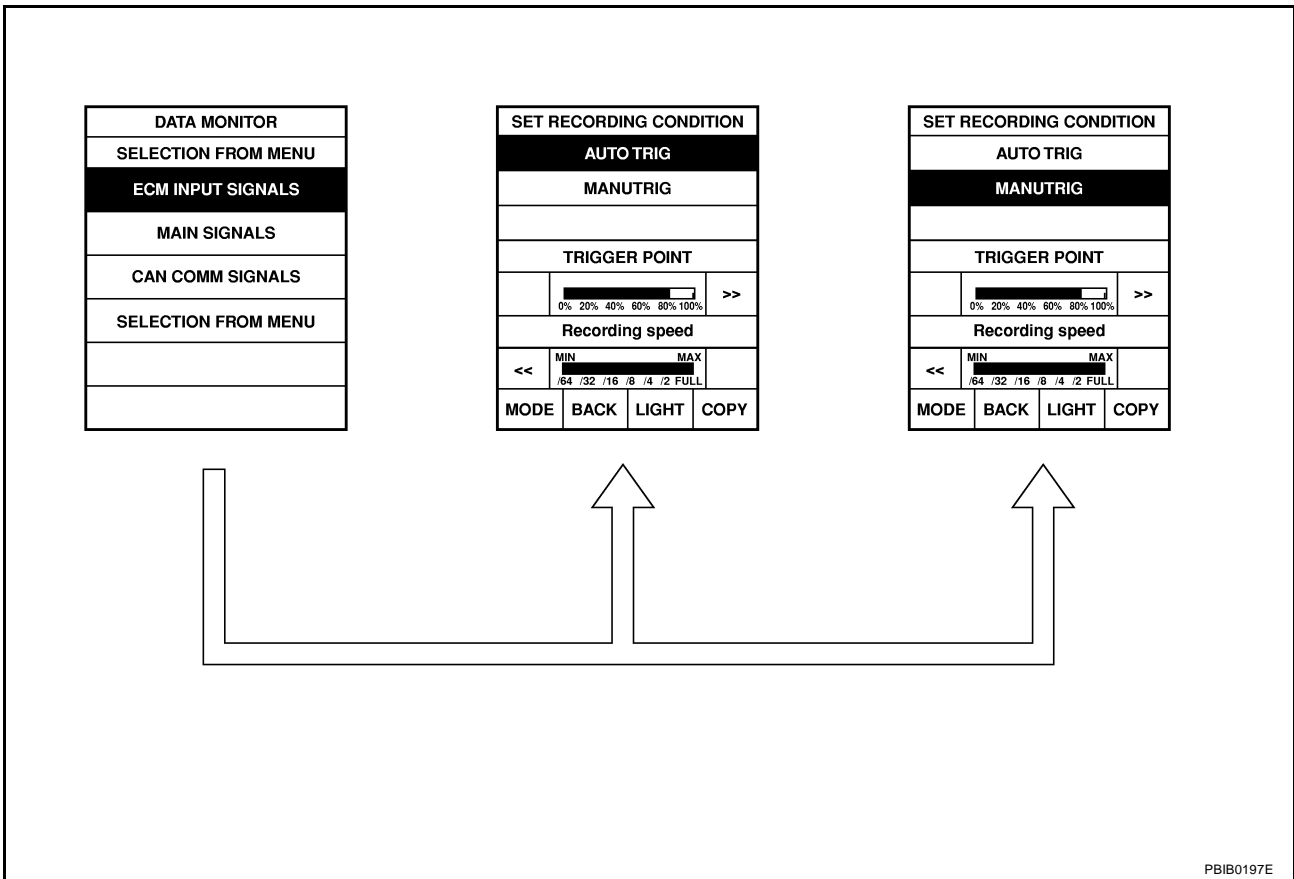

Generic Scan Tool (GST) Function DESCRIPTION

ABS006KY

Generic Scan Tool (OBDII scan tool) complying with SAE J1978 has 8 different functions explained below. ISO9141 is used as the protocol. The name GST or Generic Scan Tool is used in this service manual.

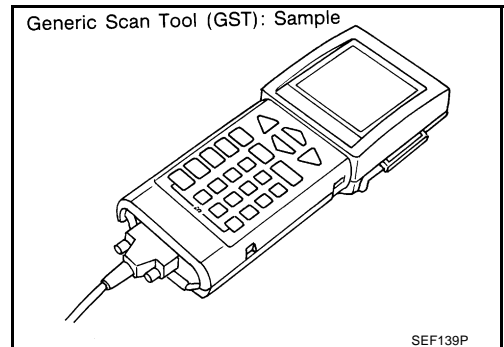

TROUBLE DIAGNOSIS

[VQ35DE]

FUNCTION

Diagnostic test mode		Function
MODE 1	READINESS TESTS	This mode gains access to current emission-related data values, including analog inputs and outputs, digital inputs and outputs, and system status information.
MODE 2	(FREEZE DATA)	This mode gains access to emission-related data value which were stored by ECM during the freeze frame. For details, refer to EC-113, "Freeze Frame Data and 1st Trip Freeze Frame Data" .
MODE 3	DTCs	This mode gains access to emission-related power train trouble codes which were stored by ECM.
MODE 4	CLEAR DIAG INFO	This mode can clear all emission-related diagnostic information. This includes: <ul style="list-style-type: none"> ● Clear number of diagnostic trouble codes (MODE 1) ● Clear diagnostic trouble codes (MODE 3) ● Clear trouble code for freeze frame data (MODE 1) ● Clear freeze frame data (MODE 2) ● Reset status of system monitoring test (MODE 1) ● Clear on board monitoring test results (MODE 6 and 7)
MODE 6	(ON BOARD TESTS)	This mode accesses the results of on board diagnostic monitoring tests of specific components/systems that are not continuously monitored.
MODE 7	(ON BOARD TESTS)	This mode enables the off board test drive to obtain test results for emission-related power train components/systems that are continuously monitored during normal driving conditions.
MODE 8	—	This mode can close EVAP system in ignition switch ON position (Engine stopped). When this mode is performed, EVAP canister vent control valve can be closed. <ul style="list-style-type: none"> ● EVAP canister vent control valve open In the following conditions, this mode cannot function. <ul style="list-style-type: none"> ● Low ambient temperature ● Low battery voltage ● Engine running ● Ignition switch OFF ● Low fuel temperature ● Too much pressure is applied to EVAP system
MODE 9	(CALIBRATION ID)	This mode enables the off-board test device to request specific vehicle information such as Vehicle Identification Number (VIN) and Calibration IDs.

INSPECTION PROCEDURE

1. Turn ignition switch OFF.
2. Connect GST to data link connector, which is located under LH dash panel near the hood opener handle.

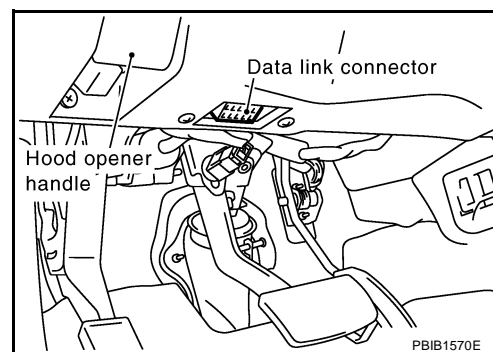

3. Turn ignition switch ON.
4. Enter the program according to instruction on the screen or in the operation manual.
(*: Regarding GST screens in this section, sample screens are shown.)

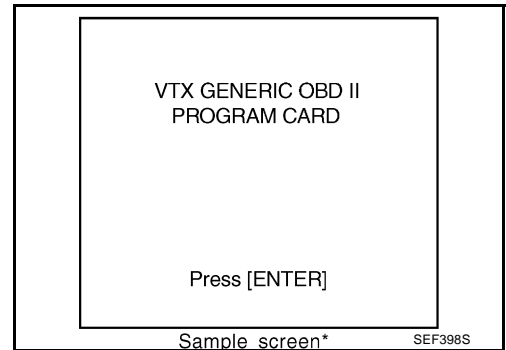

5. Perform each diagnostic mode according to each service procedure.
For further information, see the GST Operation Manual of the tool maker.

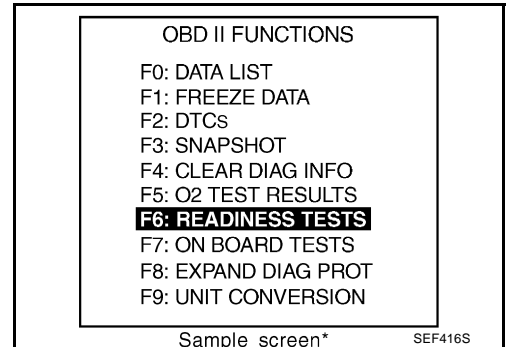

CONSULT-II Reference Value in Data Monitor

Remarks:

- Specification data are reference values.
- Specification data are output/input values which are detected or supplied by the ECM at the connector.
- * Specification data may not be directly related to their components signals/values/operations.
 - i.e. Adjust ignition timing with a timing light before monitoring IGN TIMING, because the monitor may show the specification data in spite of the ignition timing not being adjusted to the specification data. This IGN TIMING monitors the data calculated by the ECM according to the signals input from the camshaft position sensor and other ignition timing related sensors.

MONITOR ITEM	CONDITION		SPECIFICATION
ENG SPEED	● Run engine and compare CONSULT-II value with the tachometer indication.		Almost the same speed as the tachometer indication.
MAS A/F SE-B1	See EC-131, "TROUBLE DIAGNOSIS - SPECIFICATION VALUE" .		
B/FUEL SCHDL	See EC-131, "TROUBLE DIAGNOSIS - SPECIFICATION VALUE" .		
A/F ALPHA-B1 A/F ALPHA-B2	See EC-131, "TROUBLE DIAGNOSIS - SPECIFICATION VALUE" .		
COOLAN TEMP/S	● Engine: After warming up		More than 70°C (158°F)
HO2S1 (B1) HO2S1 (B2)	● Engine: After warming up	Maintaining engine speed at 2,000 rpm	0 - 0.3V ↔ Approx. 0.6 - 1.0V
HO2S2 (B1) HO2S2 (B2)	<ul style="list-style-type: none"> ● Warm-up condition ● After keeping engine speed between 3,500 and 4,000 rpm for 1 minute and at idle for 1 minute under no load. 	Revving engine from idle to 3,000 rpm quickly	0 - 0.3V ↔ Approx. 0.6 - 1.0V
HO2S1 MNTR (B1) HO2S1 MNTR (B2)	● Engine: After warming up	Maintaining engine speed at 2,000 rpm	LEAN ↔ RICH Changes more than 5 times during 10 seconds.
HO2S2 MNTR (B1) HO2S2 MNTR (B2)	<ul style="list-style-type: none"> ● Warm-up condition ● After keeping engine speed between 3,500 and 4,000 rpm for 1 minute and at idle for 1 minute under no load. 	Revving engine from idle to 3,000 rpm quickly	LEAN ↔ RICH
VEH SPEED SE	● Turn drive wheels and compare CONSULT-II value with the speedometer indication.		Almost the same speed as the speedometer indication
BATTERY VOLT	● Ignition switch: ON (Engine stopped)		11 - 14V
ACCEL SEN1	● Ignition switch: ON (Engine stopped)	Accelerator pedal: Fully released	0.5 - 1.0V
		Accelerator pedal: Fully depressed	4.0 - 4.8V
ACCEL SEN2*	● Ignition switch: ON (Engine stopped)	Accelerator pedal: Fully released	0.3 - 1.2V
		Accelerator pedal: Fully depressed	3.9 - 4.8V
THRTL SEN1 THRTL SEN2*	<ul style="list-style-type: none"> ● Ignition switch: ON (Engine stopped) ● Shift lever: D 	Accelerator pedal: Fully released	More than 0.36V
		Accelerator pedal: Fully depressed	Less than 4.75V
EVAP SYS PRES	● Ignition switch: ON		Approx. 1.8 - 4.8V
START SIGNAL	● Ignition switch: ON → START → ON		OFF → ON → OFF
CLSD THL POS	● Ignition switch: ON (Engine stopped)	Accelerator pedal: Fully released	ON
		Accelerator pedal: Slightly depressed	OFF
AIR COND SIG	● Engine: After warming up, idle the engine	Air conditioner switch: OFF	OFF
		Air conditioner switch: ON (Compressor operates.)	ON
P/N POSI SW	● Ignition switch: ON	Shift lever: P or N	ON
		Shift lever: Except above	OFF
PW/ST SIGNAL	● Engine: After warming up, idle the engine	Steering wheel is in neutral position (Forward direction)	OFF
		Steering wheel is turned.	ON

TROUBLE DIAGNOSIS

[VQ35DE]

MONITOR ITEM	CONDITION	SPECIFICATION
LOAD SIGNAL	<ul style="list-style-type: none"> ● Ignition switch: ON 	Rear window defogger switch is ON and/or lighting switch is in 2nd ON
		Rear window defogger switch is OFF and lighting switch is OFF OFF
SNOW MODE SW	<ul style="list-style-type: none"> ● Ignition switch: ON 	Snow mode switch: ON ON
		Snow mode switch: OFF OFF
IGNITION SW	<ul style="list-style-type: none"> ● Ignition switch: ON → OFF → ON 	ON → OFF → ON
HEATER FAN SW	<ul style="list-style-type: none"> ● Engine: After warming up, idle the engine 	Heater fan is operating. ON
		Heater fan is not operating OFF
BRAKE SW	<ul style="list-style-type: none"> ● Ignition switch: ON 	Brake pedal: Fully released OFF
		Brake pedal: Slightly depressed ON
INJ PULSE-B1 INJ PULSE-B2	<ul style="list-style-type: none"> ● Engine: After warming up ● Shift lever: P or N ● Air conditioner switch: OFF ● No-load 	Idle 2.0 - 3.0 msec
		2,000 rpm 1.9 - 2.9 msec
IGN TIMING	<ul style="list-style-type: none"> ● Engine: After warming up ● Shift lever: P or N ● Air conditioner switch: OFF ● No-load 	Idle 13° - 18° BTDC
		2,000 rpm 25° - 45° BTDC
CAL/LD VALUE	<ul style="list-style-type: none"> ● Engine: After warming up ● Shift lever: P or N ● Air conditioner switch: OFF ● No-load 	Idle 5% - 35%
		2,500 rpm 5% - 35%
MASS AIRFLOW	<ul style="list-style-type: none"> ● Engine: After warming up ● Shift lever: P or N ● Air conditioner switch: OFF ● No-load 	Idle 2.0 - 6.0 g-m/s
		2,500 rpm 7.0 - 20.0 g-m/s
PURG VOL C/V	<ul style="list-style-type: none"> ● Engine: After warming up ● Shift lever: P or N ● Air conditioner switch: OFF ● No-load 	Idle 0%
		2,000 rpm —
INT/V TIM (B1) INT/V TIM (B2)	<ul style="list-style-type: none"> ● Engine: After warming up ● Shift lever: P or N ● Air conditioner switch: OFF ● No-load 	Idle -5° - 5°CA
		When revving engine up to 2,000 rpm quickly Approx. 0° - 30°CA
INT/V SOL (B1) INT/V SOL (B2)	<ul style="list-style-type: none"> ● Engine: After warming up ● Shift lever: P or N ● Air conditioner switch: OFF ● No-load 	Idle 0% - 2%
		When revving engine up to 2,000 rpm quickly Approx. 0% - 50%
AIR COND RLY	<ul style="list-style-type: none"> ● Engine: After warming up, idle the engine 	Air conditioner switch: OFF OFF
		Air conditioner switch: ON (Compressor operates) ON
FUEL PUMP RLY	<ul style="list-style-type: none"> ● For 1 second after turning ignition switch ON ● Engine running or cranking ● Except above conditions 	ON
		OFF
VENT CONT/V	<ul style="list-style-type: none"> ● Ignition switch: ON 	OFF
THRTL RELAY	<ul style="list-style-type: none"> ● Ignition switch: ON 	ON

TROUBLE DIAGNOSIS

[VQ35DE]

MONITOR ITEM	CONDITION	SPECIFICATION
COOLING FAN	Engine coolant temperature is 94°C (201°F) or less	OFF
	● Engine: After warming up, idle the engine ● Air conditioner switch: OFF	Engine coolant temperature is between 95°C (203°F) and 99°C (210°F) LOW
		Engine coolant temperature is between 100°C (212°F) and 104°C (219°F) MID
		Engine coolant temperature is 105°C (221°F) or more HI
HO2S1 HTR (B1) HO2S1 HTR (B2)	● Engine: After warming up ● Engine speed: Below 3,600 rpm	ON
	● Engine speed: Above 3,600 rpm	OFF
HO2S2 HTR (B1) HO2S2 HTR (B2)	● Engine speed is below 3,600 rpm after the following conditions are met. – Engine: After warming up – Keeping the engine speed between 3,500 and 4,000 rpm for 1 minute and at idle for 1 minute under no load	ON
	● Engine speed: Above 3,600 rpm	OFF
I/P PULLY SPD	● Vehicle speed: More than 20 km/h (12 MPH)	Almost the same speed as the speedometer indication
VEHICLE SPEED	● Turn drive wheels and compare the CONSULT-II value with speedometer indication.	Almost the same speed as the speedometer indication
TRVL AFTER MIL	● Ignition switch: ON	Vehicle has traveled after MIL has turned ON. 0 - 65,535 km (0 - 40,723 mile)
O2SEN HTR DTY	● Engine coolant temperature when engine started: More than 80°C (176°F) ● Engine speed: Below 3,600 rpm	Approx. 40%
AC PRESS SEN	● Engine: Idle ● Both A/C switch and blower fan switch: ON (Compressor operates)	1.0 - 4.0V
VEH SPEED SE	● Turn drive wheels and compare speedometer indication with the CONSULT-II value.	Almost the same speed as the CONSULT-II value
SET VHCL SPD	● Engine: Running	ASCD: Operating. The preset vehicle speed is displayed.
MAIN SW	● Ignition switch: ON	ON/OFF(MAIN) switch: Pressed ON
		ON/OFF(MAIN) switch: Released OFF
CANCEL SW	● Ignition switch: ON	CANCEL switch: Pressed ON
		CANCEL switch: Released OFF
RESUME/ACC SW	● Ignition switch: ON	ACCEL/RESUME switch: Pressed ON
		ACCEL/RESUME switch: Released OFF
SET SW	● Ignition switch: ON	COAST/SET switch: Pressed ON
		COAST/SET switch: Released OFF
BRAKE SW1	● Ignition switch: ON	Brake pedal: Fully released ON
		Brake pedal: Slightly depressed OFF
BRAKE SW2	● Ignition switch: ON	Brake pedal: Fully released OFF
		Brake pedal: Slightly depressed ON
CRUISE LAMP	● Ignition switch: ON	ON/OFF(MAIN) switch: pressed at the 1st time → at the 2nd time ON → OFF
SET LAMP	● ON/OFF(MAIN) switch: ON ● When vehicle speed is between 40km/h (25MPH) and 144km/h (89MPH)	ASCD is operating ON
		ASCD is not operating OFF

TROUBLE DIAGNOSIS

[VQ35DE]

*: Accelerator pedal position sensor 2 signal and throttle position sensor 2 signal are converted by ECM internally. Thus, they differ from ECM terminals voltage signal.

Major Sensor Reference Graph in Data Monitor Mode

The following are the major sensor reference graphs in "DATA MONITOR" mode.

CLSD THL POS, ACCEL SEN 1, THRTL SEN 1

Below is the data for "CLSD THL POS", "ACCEL SEN 1" and "THRTL SEN 1" when depressing the accelerator pedal with the ignition switch ON and with selector lever in D position.

The signal of "ACCEL SEN 1" and "THRTL SEN 1" should rise gradually without any intermittent drop or rise after "CLSD THL POS" is changed from ON to OFF.

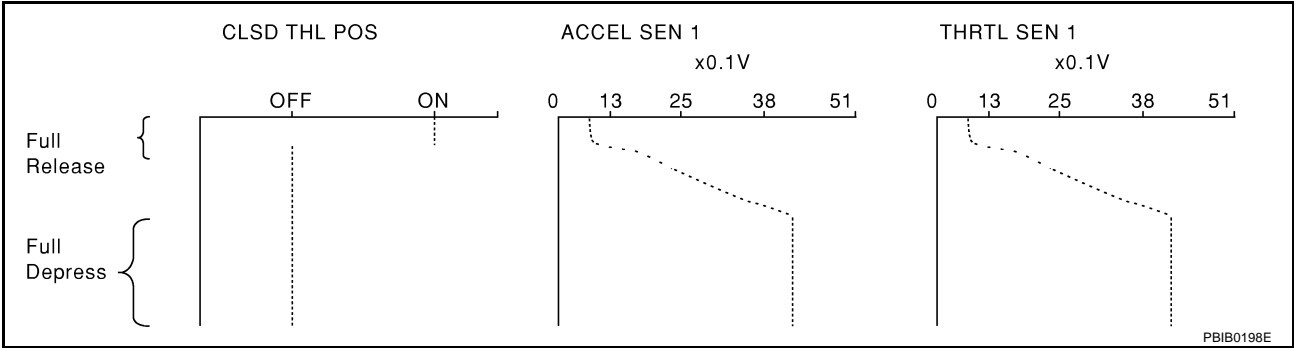

ENG SPEED, MAS A/F SE-B1, THRTL SEN 1, HO2S2 (B1), HO2S1 (B1), INJ PULSE-B1

Below is the data for "ENG SPEED", "MAS A/F SE-B1", "THRTL SEN 1", "HO2S2 (B1)", "HO2S1 (B1)" and "INJ PULSE-B1" when revving engine quickly up to 4,800 rpm under no load after warming up engine sufficiently.

Each value is for reference, the exact value may vary.

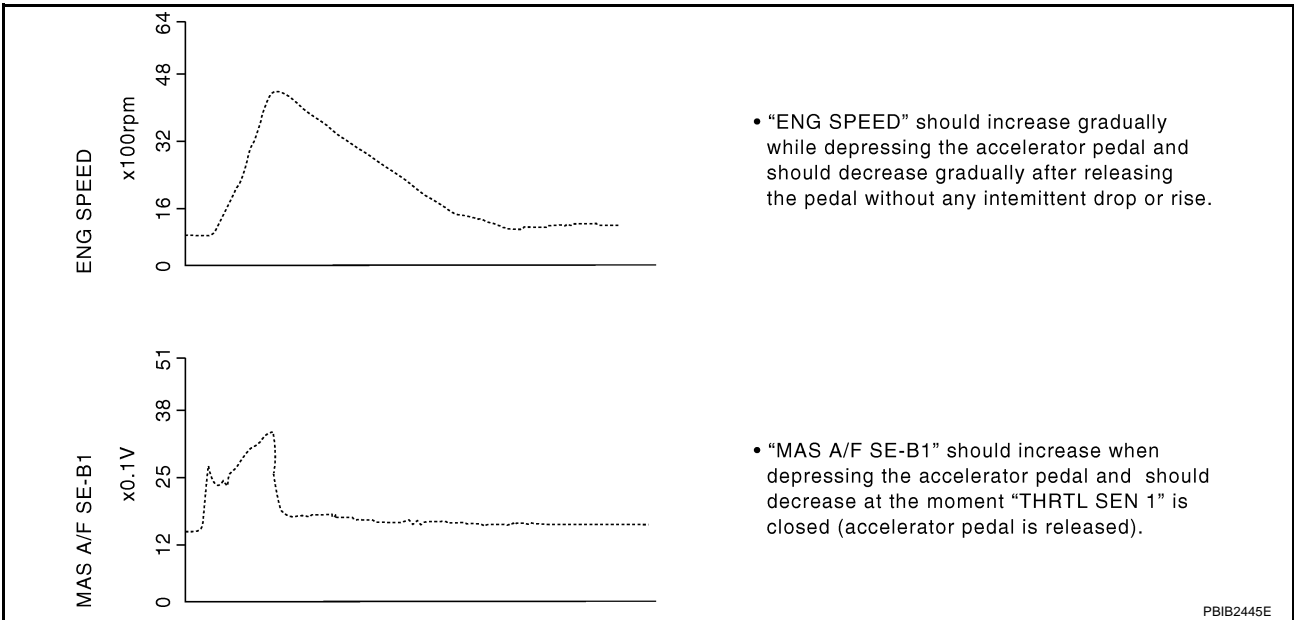



- "THRTL SEN 1" should increase while depressing the accelerator pedal and should decrease while releasing it.

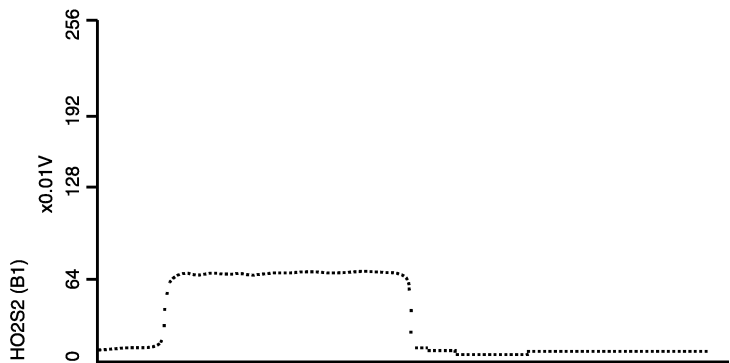

- "HO2S2 (B1)" may increase immediately after depressing the accelerator pedal and may decrease after releasing the pedal.

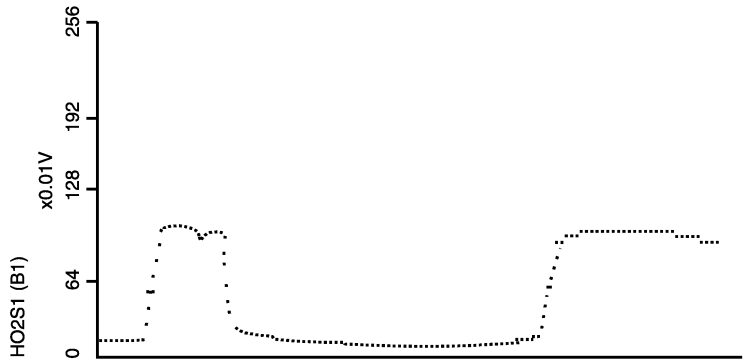

- "HO2S1 (B1)" may increase immediately after depressing the accelerator pedal and may decrease after releasing the pedal.

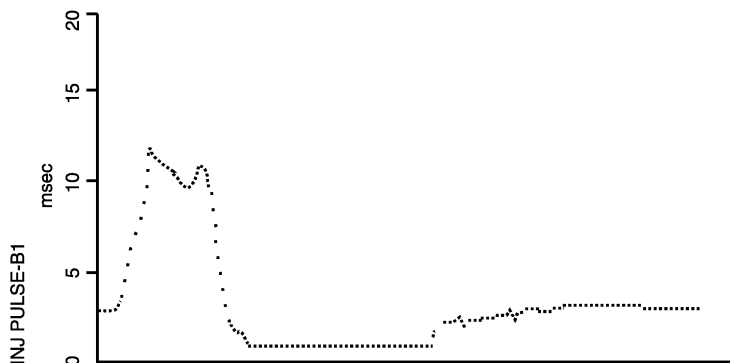

- "INJ PULSE-B1" should increase when depressing the accelerator pedal and should decrease when the pedal is released.

PBIB0668E

TROUBLE DIAGNOSIS - SPECIFICATION VALUE

PPF:00031

Description

ABS006L1

The specification (SP) value indicates the tolerance of the value that is displayed in "DATA MONITOR (SPEC)" mode of CONSULT-II during normal operation of the Engine Control System. When the value in "DATA MONITOR (SPEC)" mode is within the SP value, the Engine Control System is confirmed OK. When the value in "DATA MONITOR (SPEC)" mode is NOT within the SP value, the Engine Control System may have one or more malfunctions.

The SP value is used to detect malfunctions that may affect the Engine Control System, but will not light the MIL.

The SP value will be displayed for the following three items:

- B/FUEL SCHDL (The fuel injection pulse width programmed into ECM prior to any learned on board correction)
- A/F ALPHA-B1/B2 (The mean value of air-fuel ratio feedback correction factor per cycle)
- MAS A/F SE-B1 (The signal voltage of the mass air flow sensor)

Testing Condition

ABS006L2

- Vehicle driven distance: More than 5,000 km (3,017 miles)
- Barometric pressure: 98.3 - 104.3 kPa (1.003 - 1.064 kg/cm² , 14.25 - 15.12 psi)
- Atmospheric temperature: 20 - 30°C (68 - 86°F)
- Engine coolant temperature: 75 - 95°C (167 - 203°F)
- Transmission: Warmed-up*1
- Electrical load: Not applied*2
- Engine speed: Idle

*1: After the engine is warmed up to normal operating temperature, drive vehicle until "FLUID TEMP SE" (A/T fluid temperature sensor signal) indicates more than 60°C (140°F).

*2: Rear window defogger switch, air conditioner switch, lighting switch are OFF. Steering wheel is straight ahead.

Inspection Procedure

ABS006L3

NOTE:

Perform "DATA MONITOR (SPEC)" mode in maximum scale display.

1. Perform [EC-83, "Basic Inspection"](#) .
2. Confirm that the testing conditions indicated above are met.
3. Select "B/FUEL SCHDL", "A/F ALPHA-B1", "A/F ALPHA-B2" and "MAS A/F SE-B1" in "DATA MONITOR (SPEC)" mode with CONSULT-II.
4. Make sure that monitor items are within the SP value.
5. If NG, go to [EC-132, "Diagnostic Procedure"](#) .

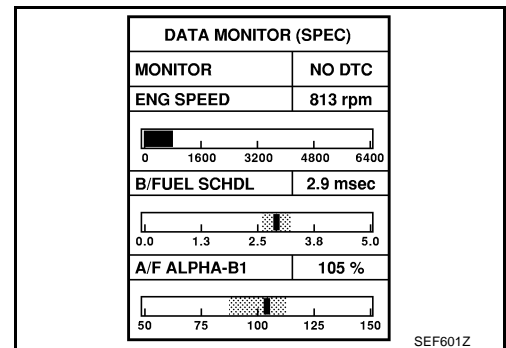

Diagnostic Procedure

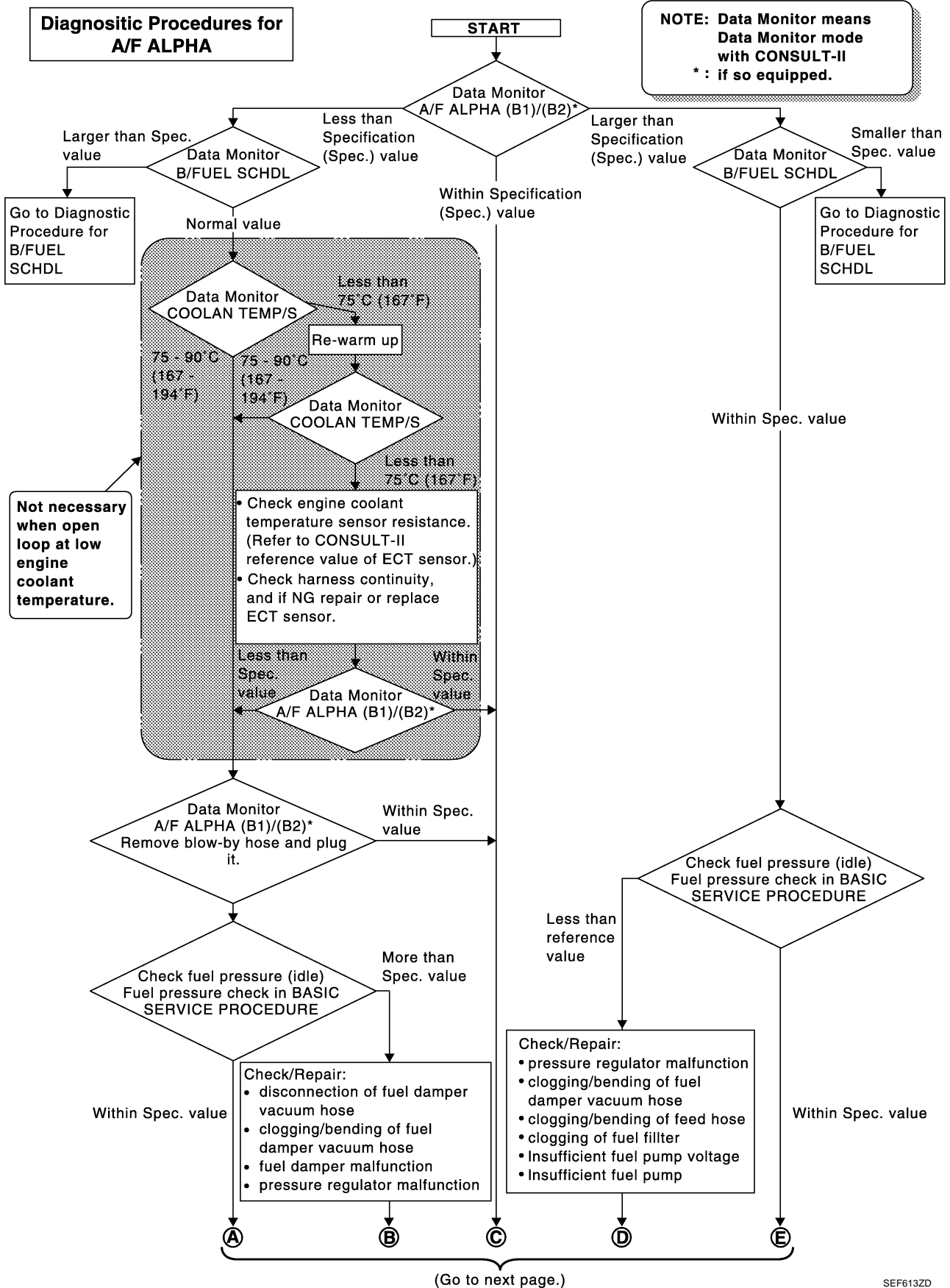

A
EC
C
D
E
F
G
H
I
J
K
L
M

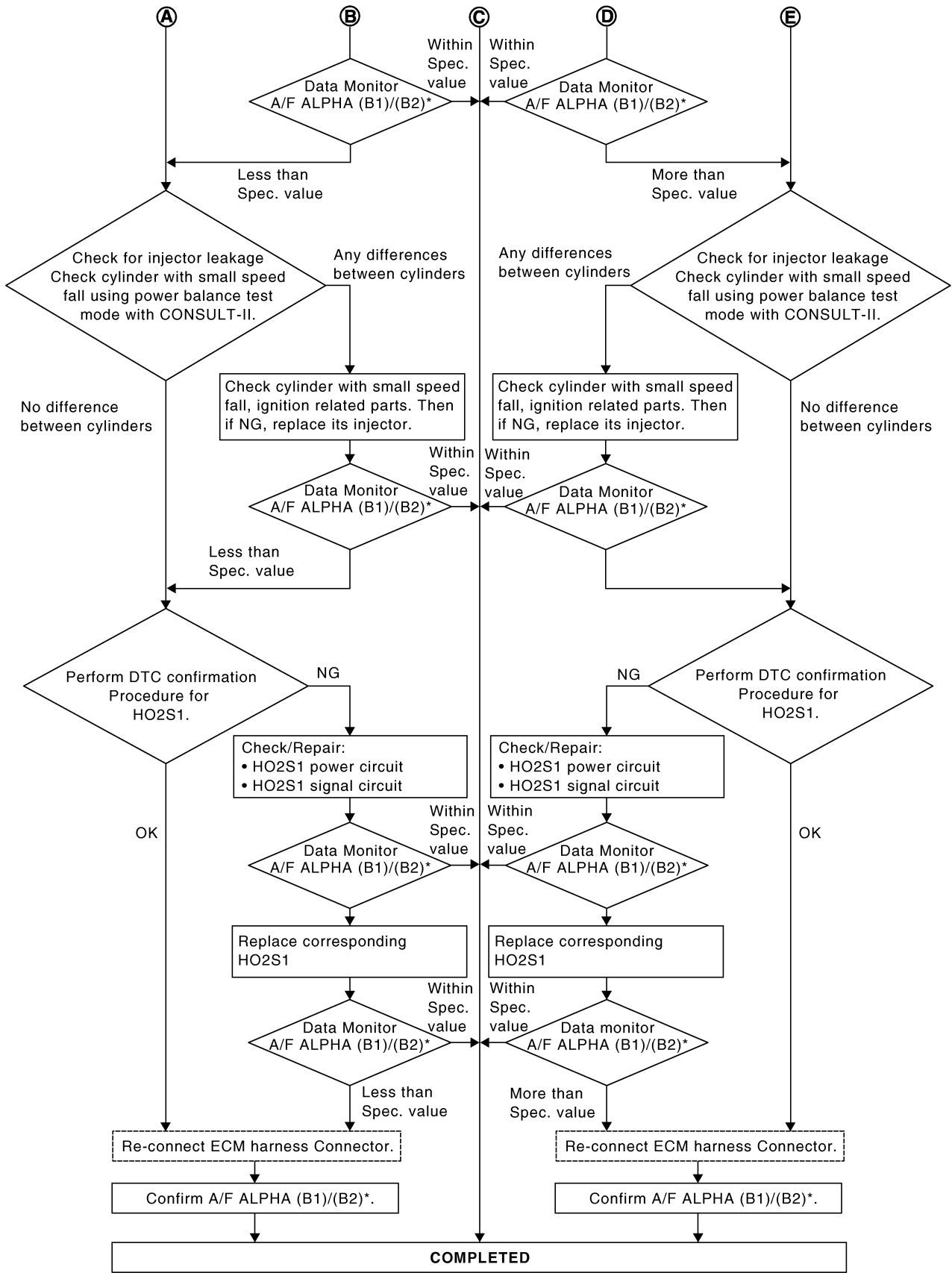

SEF768Z

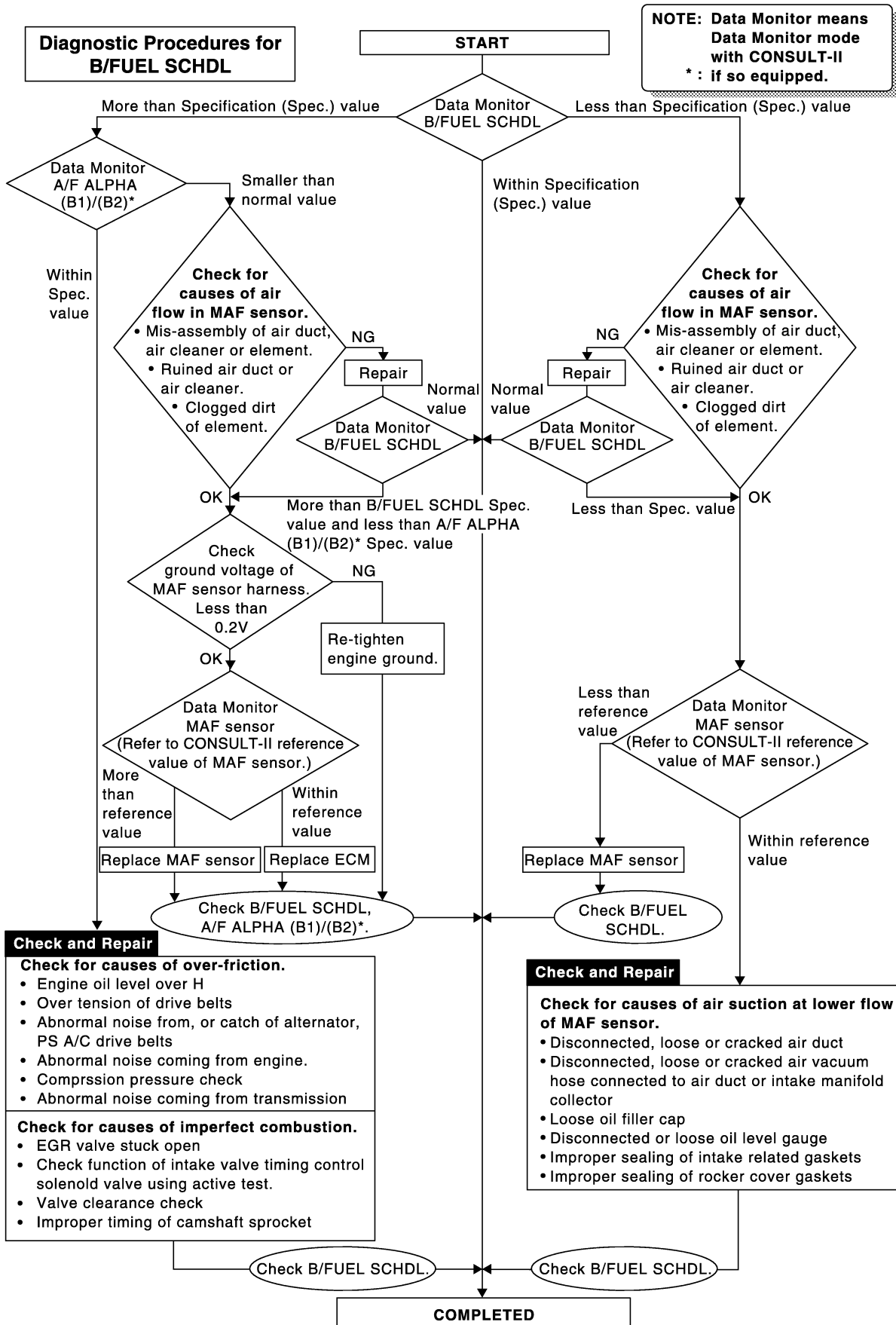

SEF615ZA

TROUBLE DIAGNOSIS FOR INTERMITTENT INCIDENT

PFP:00006

Description

ABS006L5

Intermittent incidents (I/I) may occur. In many cases, the malfunction resolves itself (the part or circuit function returns to normal without intervention). It is important to realize that the symptoms described in the customer's complaint often do not recur on (1st trip) DTC visits. Realize also that the most frequent cause of I/I occurrences is poor electrical connections. Because of this, the conditions under which the incident occurred may not be clear. Therefore, circuit checks made as part of the standard diagnostic procedure may not indicate the specific malfunctioning area.

Common I/I Report Situations

STEP in Work Flow	Situation
II	The CONSULT-II is used. The SELF-DIAG RESULTS screen shows time data other than [0] or [1t].
III	The symptom described by the customer does not recur.
IV	(1st trip) DTC does not appear during the DTC Confirmation Procedure.
VI	The Diagnostic Procedure for PXXXX does not indicate the malfunctioning area.

Diagnostic Procedure

ABS006L6

1. INSPECTION START

Erase (1st trip) DTCs. Refer to [EC-67, "HOW TO ERASE EMISSION-RELATED DIAGNOSTIC INFORMATION"](#).

>> GO TO 2.

2. CHECK GROUND TERMINALS

Check ground terminals for corroding or loose connection.

Refer to [GI-27, "How to Perform Efficient Diagnosis for an Electrical Incident"](#), "CIRCUIT INSPECTION", "Ground Inspection".

OK or NG

OK >> GO TO 3.

NG >> Repair or replace.

3. SEARCH FOR ELECTRICAL INCIDENT

Perform [GI-27, "How to Perform Efficient Diagnosis for an Electrical Incident"](#), "INCIDENT SIMULATION TESTS".

OK or NG

OK >> GO TO 4.

NG >> Repair or replace.

4. CHECK CONNECTOR TERMINALS

Refer to [GI-24, "How to Check Terminal"](#), "HOW TO PROBE CONNECTORS", "How to Check Enlarged Contact Spring of Terminal".

OK or NG

OK >> **INSPECTION END**

NG >> Repair or replace connector.

POWER SUPPLY AND GROUND CIRCUIT

PFP:24110

Wiring Diagram

ABS006L7

EC-MAIN-01

— : DETECTABLE LINE FOR DTC
 — : NON-DETECTABLE LINE FOR DTC

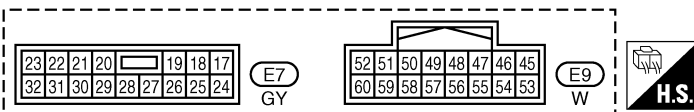
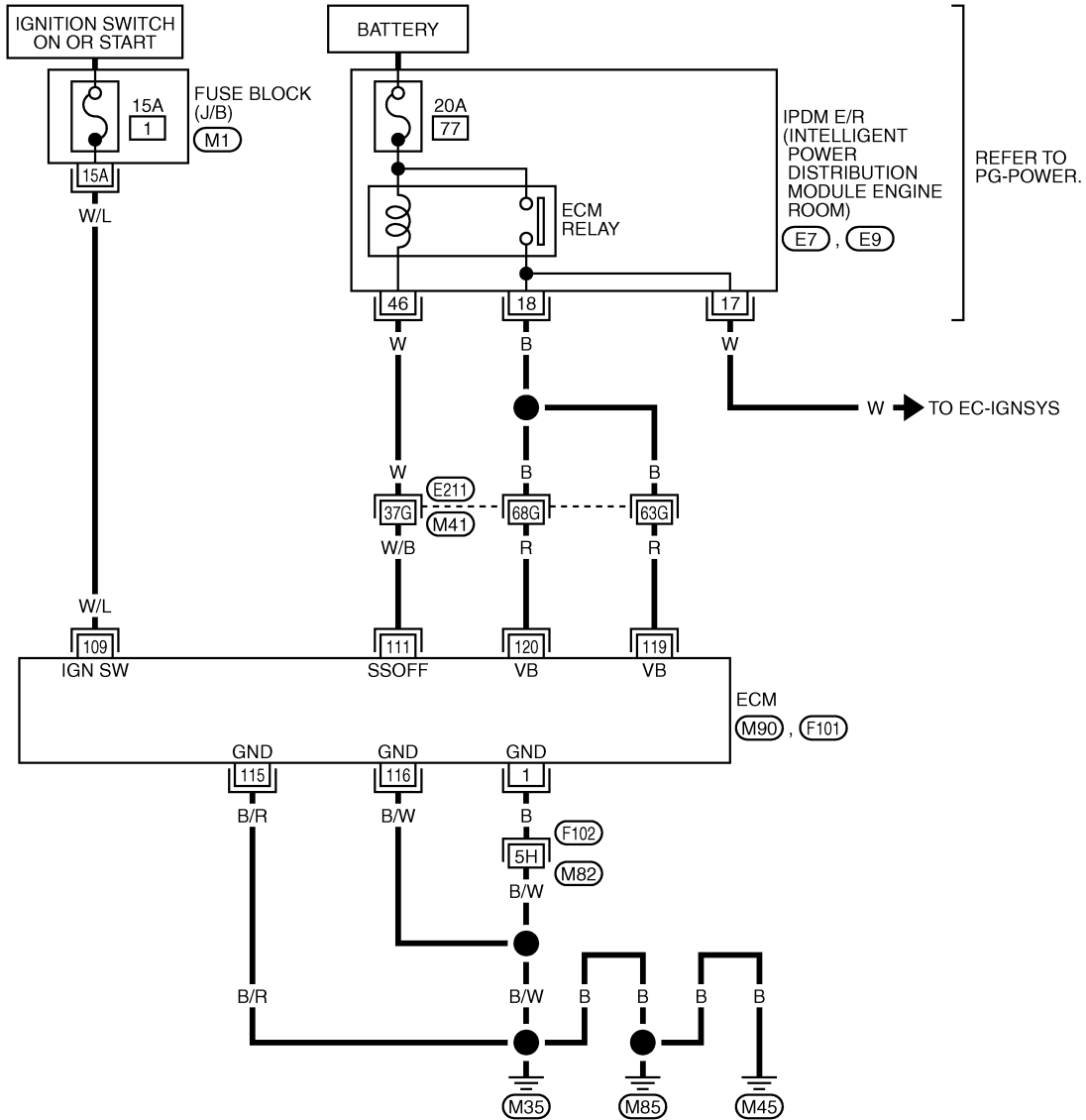

REFER TO THE FOLLOWING.
 (E21), (F102) -SUPER MULTIPLE JUNCTION (SMJ)
 (M1) -FUSE BLOCK-JUNCTION BOX (J/B)

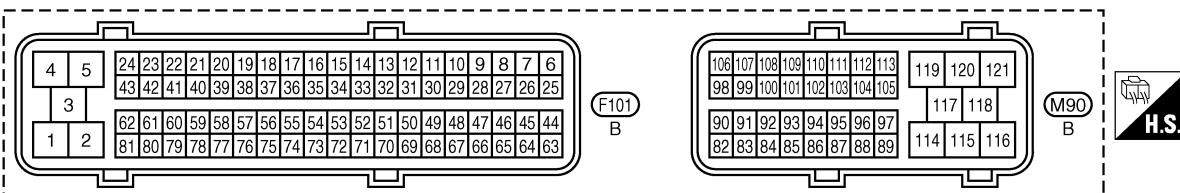

TBWM0217E

POWER SUPPLY AND GROUND CIRCUIT

[VQ35DE]

Specification data are reference values and are measured between each terminal and ground.

CAUTION:

Do not use ECM ground terminals when measuring input/output voltage. Doing so may result in damage to the ECM's transistor. Use a ground other than ECM terminals, such as the ground.

TER-MINAL NO.	WIRE COLOR	ITEM	CONDITION	DATA (DC Voltage)
1	B	ECM ground	[Engine is running] ● Idle speed	Body ground
109	W/L	Ignition switch	[Ignition switch: OFF]	0V
			[Ignition switch: ON]	BATTERY VOLTAGE (11 - 14V)
111	W/B	ECM relay (Self shut-off)	[Engine is running] [Ignition switch: OFF] ● For a few seconds after turning ignition switch OFF	0 - 1.5V
			[Ignition switch: OFF] ● More than a few seconds after turning ignition switch OFF	BATTERY VOLTAGE (11 - 14V)
115 116	B/R B/W	ECM ground	[Engine is running] ● Idle speed	Body ground
119 120	R R	Power supply for ECM	[Ignition switch: ON]	BATTERY VOLTAGE (11 - 14V)

Diagnostic Procedure

ABS00CGM

1. INSPECTION START

Start engine.

Is engine running?

Yes or No

- Yes >> GO TO 8.
- No >> GO TO 2.

2. CHECK ECM POWER SUPPLY CIRCUIT-I

1. Turn ignition switch OFF and then ON.
2. Check voltage between ECM terminal 109 and ground with CONSULT-II or tester.

Voltage: Battery voltage

OK or NG

- OK >> GO TO 4.
- NG >> GO TO 3.

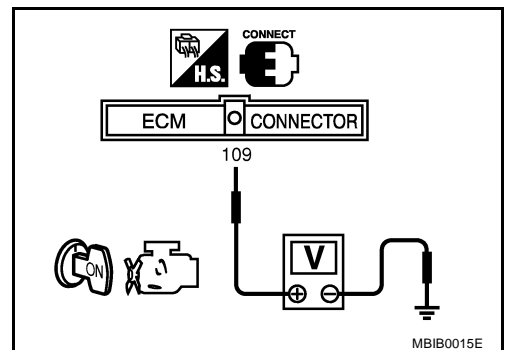

3. DETECT MALFUNCTIONING PART

Check the following.

- Fuse block (J/B) connector M1
- 15A fuse
- Harness for open or short between ECM and fuse

>> Repair harness or connectors.

4. CHECK GROUND CONNECTIONS

1. Turn ignition switch OFF.
2. Loosen and retighten ground three screws on the body. Refer to [EC-141, "Ground Inspection"](#) .

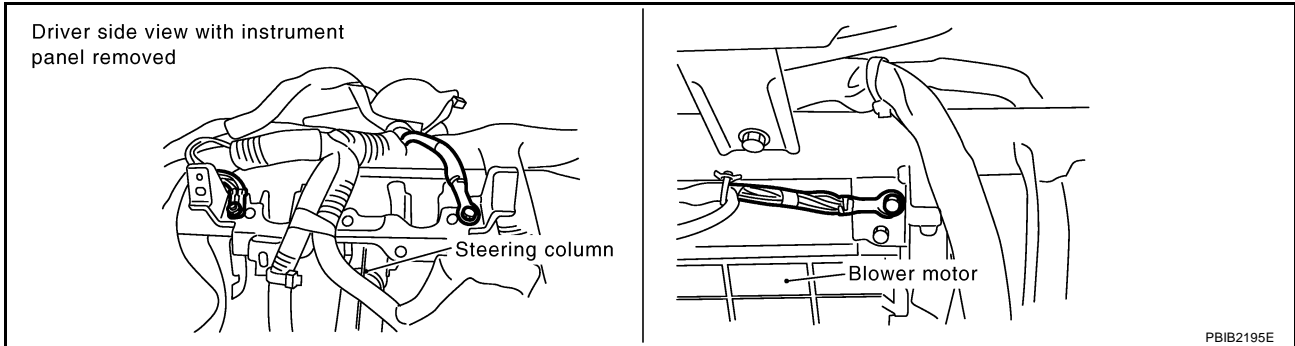

OK or NG

- OK >> GO TO 5.
- NG >> Repair or replace ground connections.

5. CHECK ECM GROUND CIRCUIT FOR OPEN AND SHORT-I

1. Disconnect ECM harness connector.
2. Check harness continuity between ECM terminals 1, 115, 116 and body ground. Refer to Wiring Diagram.

Continuity should exist.

3. Also check harness for short to power.

OK or NG

- OK >> GO TO 7.
- NG >> GO TO 6.

6. DETECT MALFUNCTIONING PART

Check the following.

- Harness connectors F102, M82
- Harness for open or short between ECM and body ground

>> Repair open circuit or short to power in harness or connectors.

7. CHECK ECM POWER SUPPLY CIRCUIT-II

1. Reconnect ECM harness connector.
2. Turn ignition switch ON.
3. Check voltage between IPDM E/R connector E7 terminal 17 and ground with CONSULT-II or tester.

Voltage: Battery voltage

OK or NG

- OK >> Go to [EC-585, "IGNITION SIGNAL"](#) .
- NG >> GO TO 8.

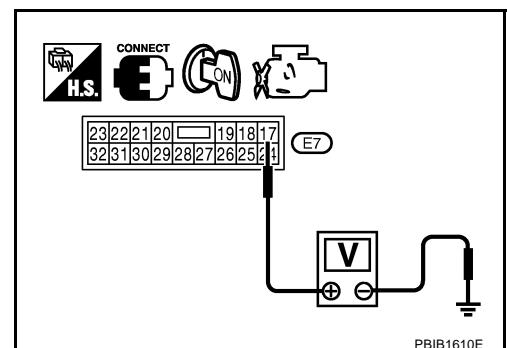

8. CHECK ECM POWER SUPPLY CIRCUIT-III

1. Turn ignition switch ON and then OFF.
2. Check voltage between ECM terminals 119, 120 and ground with CONSULT-II or tester.

Voltage: After turning ignition switch OFF, battery voltage will exist for a few seconds, then drop approximately 0V.

OK or NG

OK >> GO TO 17.

NG (Battery voltage does not exist.)>>GO TO 9.

NG (Battery voltage exists for more than a few seconds.)>>GO TO 17.

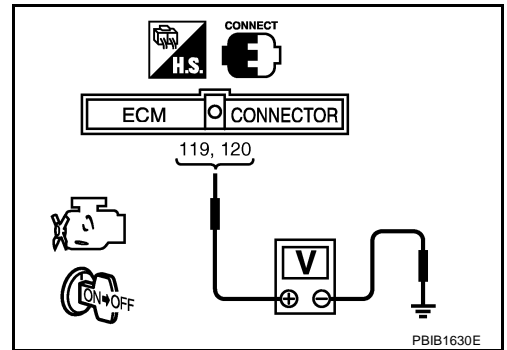

9. CHECK ECM POWER SUPPLY CIRCUIT-IV

1. Turn ignition switch OFF, and wait at least 10 seconds.
2. Check voltage between ECM terminal 111 and ground with CONSULT-II or tester.

Voltage: Battery voltage

OK or NG

OK >> GO TO 10.

NG >> GO TO 12.

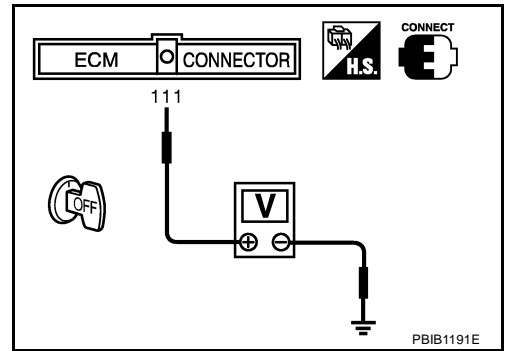

10. CHECK ECM POWER SUPPLY CIRCUIT-V

1. Disconnect ECM harness connector.
2. Disconnect IPDM E/R harness connector E7.
3. Check harness continuity between ECM terminals 119, 120 and IPDM E/R terminal 18. Refer to Wiring Diagram.

Continuity should exist.

4. Also check harness for short to ground and short to power.

OK or NG

OK >> GO TO 15.

NG >> GO TO 11.

11. DETECT MALFUNCTIONING PART

Check the following.

- Harness or connectors E211, M41
- Harness for open or short between ECM and IPDM E/R

>> Repair open circuit or short to ground or short to power in harness or connectors.

12. CHECK ECM POWER SUPPLY CIRCUIT-VI

1. Disconnect ECM harness connector.
2. Disconnect IPDM E/R harness connector E9.
3. Check harness continuity between ECM terminal 111 and IPDM E/R terminal 46.
Refer to Wiring Diagram.

Continuity should exist.

4. Also check harness for short to ground and short to power.

OK or NG

- OK >> GO TO 14.
NG >> GO TO 13.

13. DETECT MALFUNCTIONING PART

Check the following.

- Harness or connectors E211, M41
- Harness for open or short between ECM and IPDM E/R

>> Repair open circuit or short to ground or short to power in harness or connectors.

14. CHECK 20A FUSE

1. Disconnect 20 A fuse from IPDM E/R.
2. Check 20A fuse.

OK or NG

- OK >> GO TO 17.
NG >> Replace 20A fuse.

15. CHECK GROUND CONNECTIONS

Loosen and retighten ground three screws on the body. Refer to [EC-141, "Ground Inspection"](#).

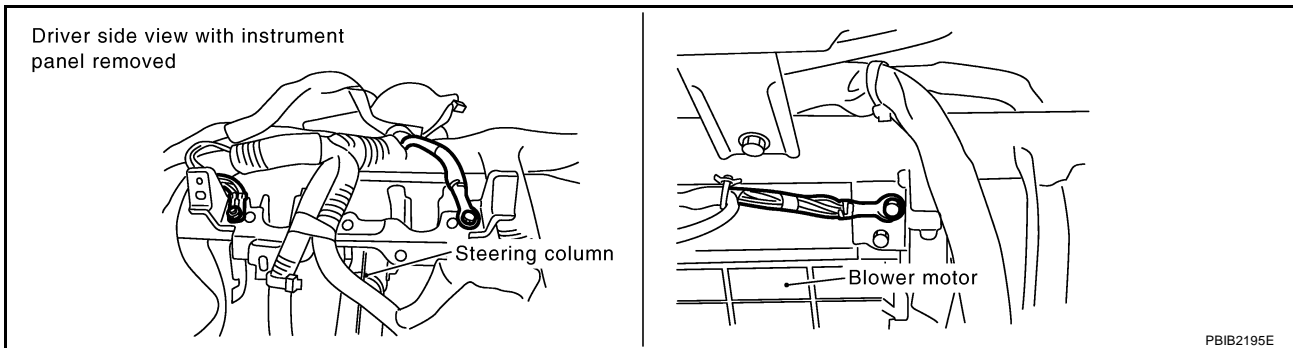

OK or NG

- OK >> GO TO 16.
NG >> Repair or replace ground connections.

16. CHECK ECM GROUND CIRCUIT FOR OPEN AND SHORT-II

1. Check harness continuity between ECM terminals 1, 115, 116 and body ground.
Refer to Wiring Diagram.

Continuity should exist.

2. Also check harness for short to power.

OK or NG

- OK >> GO TO 17.
NG >> Repair open circuit or short to power in harness.

17. CHECK INTERMITTENT INCIDENT

Refer to [EC-135, "TROUBLE DIAGNOSIS FOR INTERMITTENT INCIDENT"](#) .

OK or NG

- OK >> Replace IPDM E/R.
- NG >> Repair open circuit or short to power in harness or connectors.

Ground Inspection

ABS00CGN

Ground connections are very important to the proper operation of electrical and electronic circuits. Ground connections are often exposed to moisture, dirt and other corrosive elements. The corrosion (rust) can become an unwanted resistance. This unwanted resistance can change the way a circuit works.

Electronically controlled circuits are very sensitive to proper grounding. A loose or corroded ground can drastically affect an electronically controlled circuit. A poor or corroded ground can easily affect the circuit. Even when the ground connection looks clean, there can be a thin film of rust on the surface.

When inspecting a ground connection follow these rules:

- Remove the ground bolt or screw.
- Inspect all mating surfaces for tarnish, dirt, rust, etc.
- Clean as required to assure good contact.
- Reinstall bolt or screw securely.
- Inspect for "add-on" accessories which may be interfering with the ground circuit.
- If several wires are crimped into one ground eyelet terminal, check for proper crimps. Make sure all of the wires are clean, securely fastened and providing a good ground path. If multiple wires are cased in one eyelet make sure no ground wires have excess wire insulation.

For detailed ground distribution information, refer to [PG-31, "Ground Distribution"](#) .

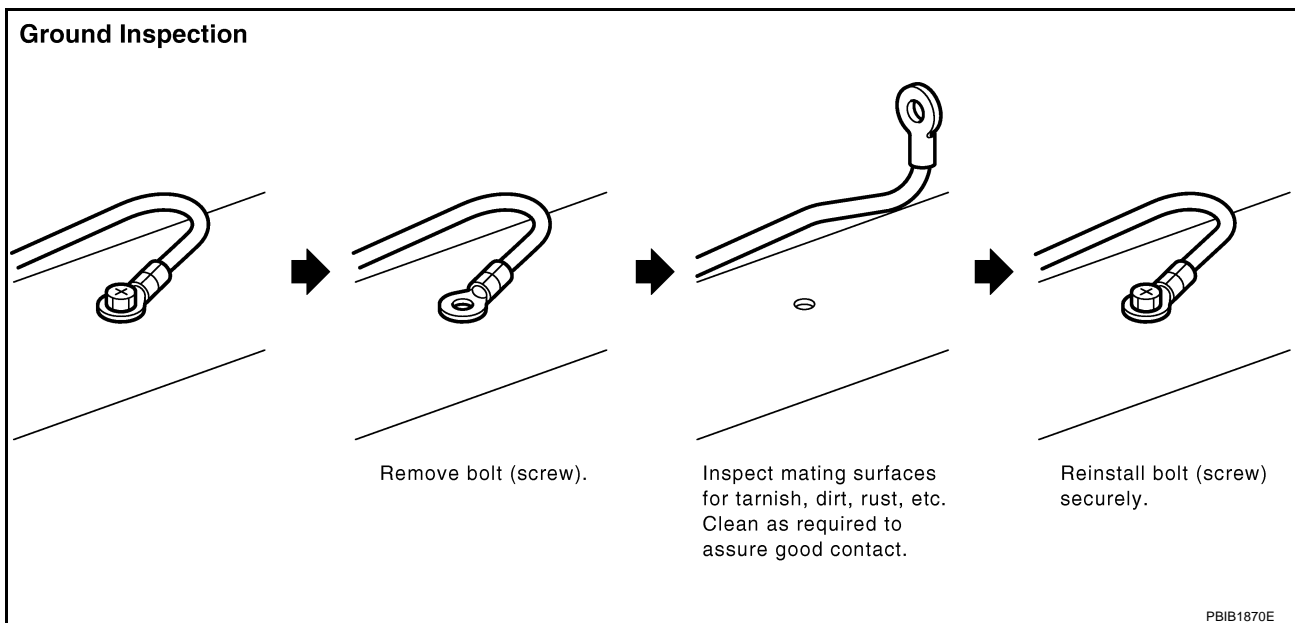

DTC U1000, U1001 CAN COMMUNICATION LINE

PFP:23710

Description

ABS006L9

CAN (Controller Area Network) is a serial communication line for real time application. It is an on-vehicle multiplex communication line with high data communication speed and excellent error detection ability. Many electronic control units are equipped onto a vehicle, and each control unit shares information and links with other control units during operation (not independent). In CAN communication, control units are connected with 2 communication lines (CAN H line, CAN L line) allowing a high rate of information transmission with less wiring. Each control unit transmits/receives data but selectively reads required data only.

On Board Diagnosis Logic

ABS006LA

DTC No.	Trouble diagnosis name	DTC detecting condition	Possible cause
U1000*1 1000*1	CAN communication line	<ul style="list-style-type: none"> ● ECM cannot communicate to other control units. ● ECM cannot communicate for more than the specified time. 	<ul style="list-style-type: none"> ● Harness or connectors (CAN communication line is open or shorted)
U1001*2 1001*2			

*1: This self-diagnosis has the one trip detection logic.

*2: The MIL will not light up for this diagnosis.

DTC Confirmation Procedure

ABS006LB

1. Turn ignition switch ON and wait at least 3 seconds.
2. Select "DATA MONITOR" mode with CONSULT-II.
3. If 1st trip DTC is detected, go to [EC-144, "Diagnostic Procedure"](#).



DTC U1000, U1001 CAN COMMUNICATION LINE

[VQ35DE]

ABS006LC

Wiring Diagram

EC-CAN-01

-  : DETECTABLE LINE FOR DTC
-  : NON-DETECTABLE LINE FOR DTC
-  : DATA LINE

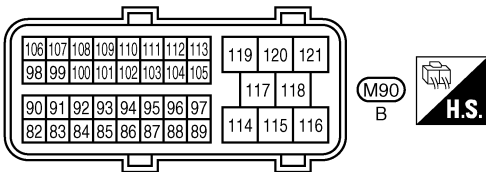
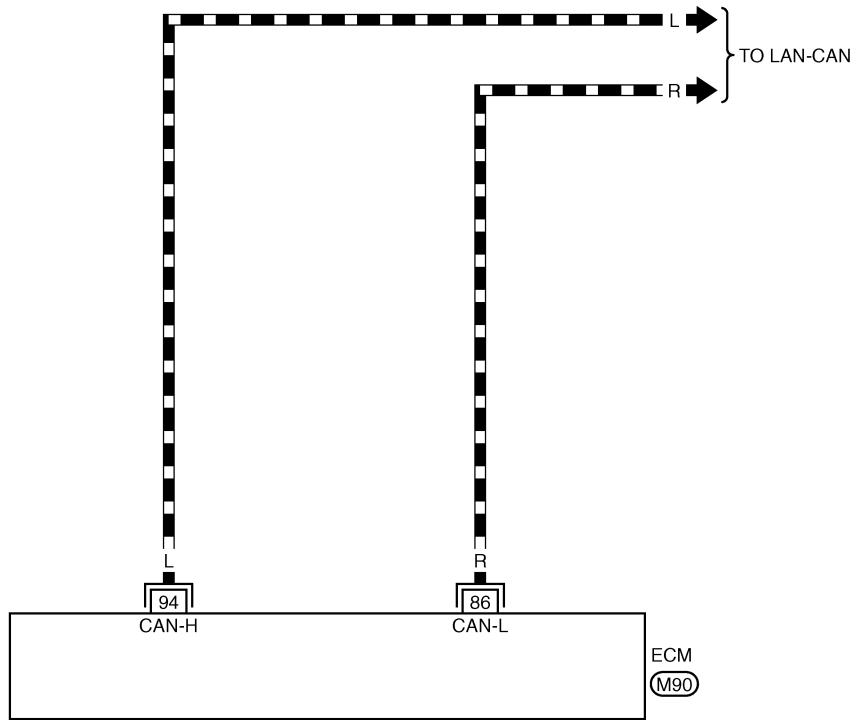

TBWM0218E

Diagnostic Procedure

ABS006LD

Go to [LAN-4, "Precautions When Using CONSULT-II"](#) .

DTC P0011, P0021 IVT CONTROL

PFP:23796

Description
SYSTEM DESCRIPTION

ABS006LE

Sensor	Input signal to ECM	ECM function	Actuator
Crankshaft position sensor (POS)	Engine speed and piston position	Intake valve timing control	Intake valve timing control solenoid valve
Camshaft position sensor (PHASE)			
Engine coolant temperature sensor	Engine coolant temperature		
Wheel sensor*	Vehicle speed		

*: This signal is sent to the ECM through CAN communication line

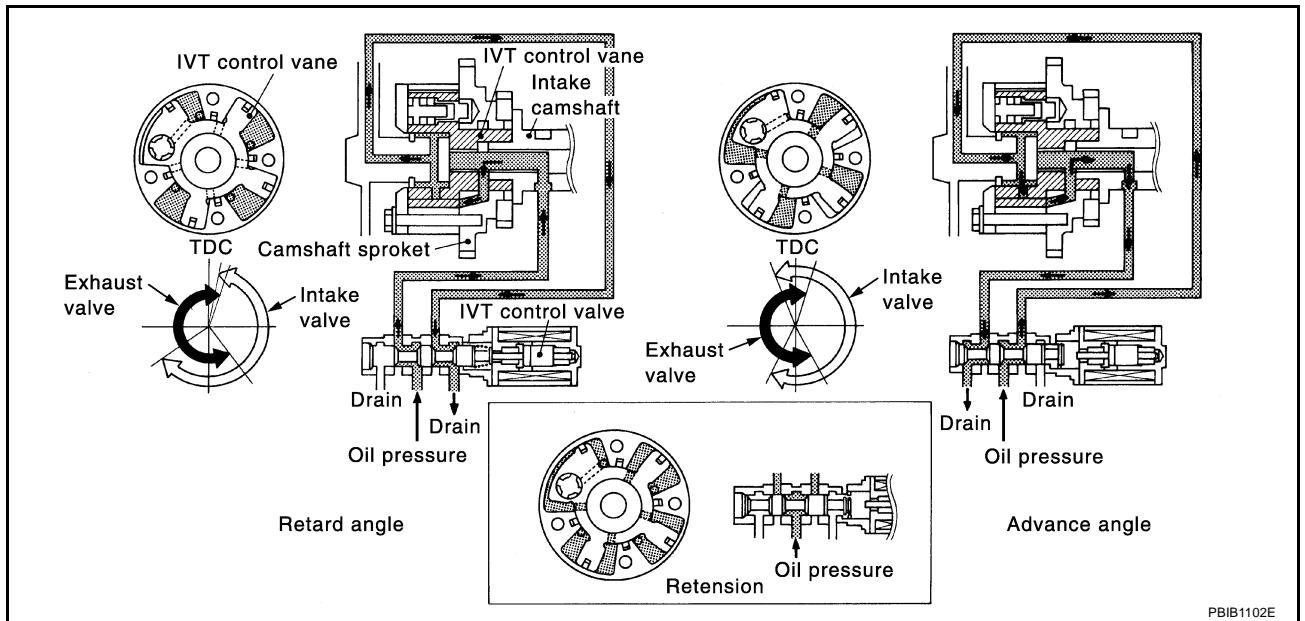

This mechanism hydraulically controls cam phases continuously with the fixed operating angle of the intake valve.

The ECM receives signals such as crankshaft position, camshaft position, engine speed, and engine coolant temperature. Then, the ECM sends ON/OFF pulse duty signals to the intake valve timing control solenoid valve depending on driving status. This makes it possible to control the shut/open timing of the intake valve to increase engine torque in low/mid speed range and output in high-speed range.

CONSULT-II Reference Value in Data Monitor Mode

ABS006LF

Specification data are reference values.

MONITOR ITEM	CONDITION	SPECIFICATION
INT/V TIM (B1) INT/V TIM (B2)	● Engine: After warming up ● Shift lever: P or N ● Air conditioner switch: OFF ● No-load Idle	-5° - 5°CA
	When revving engine up to 2,000 rpm quickly	Approx. 0° - 30°CA
INT/V SOL (B1) INT/V SOL (B2)	● Engine: After warming up ● Shift lever: P or N ● Air conditioner switch: OFF ● No-load Idle	0% - 2%
	When revving engine up to 2,000 rpm quickly	Approx. 0% - 50%

On Board Diagnosis Logic

DTC No.	Trouble diagnosis name	Detecting condition	Possible cause
P0011 0011 (Bank 1)	Intake valve timing control performance	There is a gap between angle of target and phase-control angle degree.	<ul style="list-style-type: none"> ● Crankshaft position sensor (POS) ● Camshaft position sensor (PHASE) ● Accumulation of debris to the signal pick-up portion of the camshaft
P0021 0021 (Bank 2)			

FAIL-SAFE MODE

When the malfunction is detected, the ECM enters fail-safe mode.

Detected items	Engine operating condition in fail-safe mode
Intake valve timing control	The signal is not energized to the solenoid valve and the valve control does not function.

DTC Confirmation Procedure

CAUTION:

Always drive at a safe speed.

NOTE:

- If DTC P0011 or P0021 is displayed with DTC P1111 or P1136, first perform trouble diagnosis for DTC P1111 or P1136. Refer to [EC-408](#).
- If DTC Confirmation Procedure has been previously conducted, always turn ignition switch OFF and wait at least 10 seconds before conducting the next test.

TESTING CONDITION:

Before performing the following procedure, confirm that battery voltage is between 10V and 16V at idle.

WITH CONSULT-II

1. Turn ignition switch ON and select "DATA MONITOR" mode with CONSULT-II.
2. Start engine and warm it up to the normal operating temperature.
3. Maintain the following conditions for at least 6 consecutive seconds. Hold the accelerator pedal as steady as possible.

VHCL SPEED SE	100 - 120 km/h (63 - 75 MPH)
ENG SPEED	2,000 - 4,000 rpm
COOLAN TEMP/S	60 - 120°C (140 - 248°F)
B/FUEL SCHDL	More than 7.3 msec
Selector lever	D position

DATA MONITOR	
MONITOR	NO DTC
ENG SPEED	XXX rpm
B/FUEL SCHDL	XXX msec
COOLAN TEMP/S	XXX °C
VHCL SPEED SE	XXX km/h
INT/V TIM (B1)	XXX °CA
INT/V TIM (B2)	XXX °CA
INT/V SOL (B1)	XXX %
INT/V SOL (B2)	XXX %

SEF353Z

4. Stop vehicle with engine running and let engine idle for 10 seconds.
5. If the 1st trip DTC is detected, go to [EC-148, "Diagnostic Procedure"](#).
If the 1st trip DTC is not detected, go to next step.
6. Maintain the following conditions for at least 20 consecutive seconds.

ENG SPEED	1,700 - 3,175 rpm (A constant rotation is maintained.)
COOLAN TEMP/S	70 - 105°C (158 - 221°F)
Selector lever	1st or 2nd position
Driving location uphill	Driving vehicle uphill (Increased engine load will help maintain the driving conditions required for this test.)

7. If the 1st trip DTC is detected, go to [EC-148, "Diagnostic Procedure"](#).

 **WITH GST**

Follow the procedure "WITH CONSULT-II" above.

A

EC

C

D

E

F

G

H

I

J

K

L

M

Diagnostic Procedure**1. CHECK CRANKSHAFT POSITION SENSOR (POS)**

Refer to [EC-307, "Component Inspection"](#) .

OK or NG

OK >> GO TO 2.

NG >> Replace crankshaft position sensor (POS).

2. CHECK CAMSHAFT POSITION SENSOR (PHASE)

Refer to [EC-315, "Component Inspection"](#) .

OK or NG

OK >> GO TO 3.

NG >> Replace camshaft position sensor (PHASE).

3. CHECK CAMSHAFT (INTAKE)

Check the following.

- Accumulation of debris to the signal plate of camshaft rear end
- Chipping signal plate of camshaft rear end

OK or NG

OK >> GO TO 4.

NG >> Remove debris and clean the signal plate of camshaft rear end or replace camshaft.

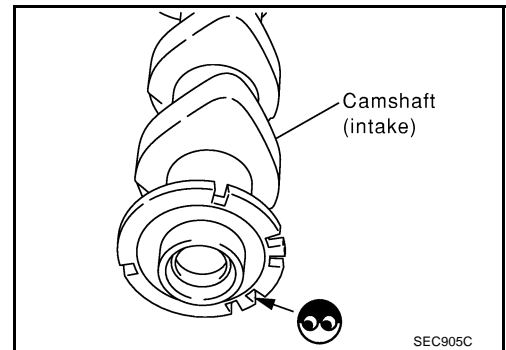
**4. CHECK INTERMITTENT INCIDENT**

Refer to [EC-135, "TROUBLE DIAGNOSIS FOR INTERMITTENT INCIDENT"](#) .

For wiring diagram, refer to [EC-303](#) for CKP sensor (POS), [EC-309](#) and [EC-311](#) for CMP sensor (PHASE).

>> **INSPECTION END**

DTC P0031, P0032, P0051, P0052 HO2S1 HEATER

[VQ35DE]

DTC P0031, P0032, P0051, P0052 HO2S1 HEATER

PF2:22690

Description SYSTEM DESCRIPTION

ABS006LJ

Sensor	Input signal to ECM	ECM function	Actuator
Camshaft position sensor (PHASE) Crankshaft position sensor (POS)	Engine speed	Heated oxygen sensor 1 heater control	Heated oxygen sensor 1 heater
Engine coolant temperature sensor	Engine coolant temperature		

The ECM performs ON/OFF control of the heated oxygen sensor 1 heater corresponding to the engine speed and engine coolant temperature. The duty percent varies with engine coolant temperature when engine is started.

OPERATION

Engine speed rpm	Heated oxygen sensor 1 heater
Above 3,600	OFF
Below 3,600 after warming up	ON

CONSULT-II Reference Value in Data Monitor Mode

ABS006LK

Specification data are reference values.

MONITOR ITEM	CONDITION	SPECIFICATION
HO2S1 HTR (B1) HO2S1 HTR (B2)	<ul style="list-style-type: none"> ● Engine: After warming up ● Engine speed: Below 3,600 rpm 	ON
	<ul style="list-style-type: none"> ● Engine speed: Above 3,600 rpm 	OFF

On Board Diagnosis Logic

ABS006LL

DTC No.	Trouble diagnosis name	DTC detecting condition	Possible cause
P0031 0031 (Bank 1)	Heated oxygen sensor 1 heater control circuit low	The current amperage in the heated oxygen sensor 1 heater circuit is out of the normal range. (An excessively low voltage signal is sent to ECM through the heated oxygen sensor 1 heater.)	<ul style="list-style-type: none"> ● Harness or connectors (The heated oxygen sensor 1 heater circuit is open or shorted.) ● Heater oxygen sensor 1 heater
P0051 0051 (Bank 2)			
P0032 0032 (Bank 1)	Heated oxygen sensor 1 heater control circuit high	The current amperage in the heated oxygen sensor 1 heater circuit is out of the normal range. (An excessively high voltage signal is sent to ECM through the heated oxygen sensor 1 heater.)	<ul style="list-style-type: none"> ● Harness or connectors (The heated oxygen sensor 1 heater circuit is shorted.) ● Heater oxygen sensor 1 heater
P0052 0052 (Bank 2)			

DTC Confirmation Procedure**NOTE:**

If DTC Confirmation Procedure has been previously conducted, always turn ignition switch OFF and wait at least 10 seconds before conducting the next test.

TESTING CONDITION:

Before performing the following procedure, confirm that battery voltage is between 10.5V and 16V at idle.

 **WITH CONSULT-II**

1. Start engine and warm it up to normal operating temperature.
2. Turn ignition switch OFF and wait at least 10 seconds.
3. Turn ignition switch ON and select "DATA MONITOR" mode with CONSULT-II.
4. Start engine and run it for at least 6 seconds at idle speed.
5. If 1st trip DTC is detected, go to [EC-154, "Diagnostic Procedure"](#)

DATA MONITOR	
MONITOR	NO DTC
ENG SPEED	XXX rpm

SEF058Y

 **WITH GST**

Follow the procedure "with CONSULT-II" above.

DTC P0031, P0032, P0051, P0052 HO2S1 HEATER

[VQ35DE]

ABS006LN

Wiring Diagram BANK 1

EC-O2H1B1-01

— : DETECTABLE LINE FOR DTC
— : NON-DETECTABLE LINE FOR DTC

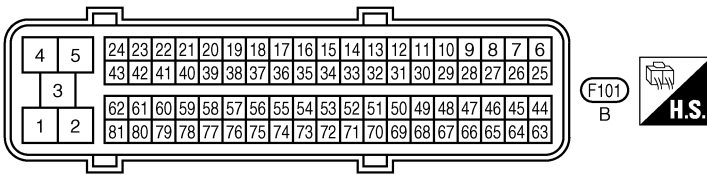
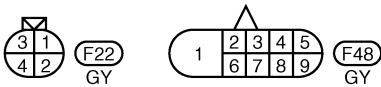
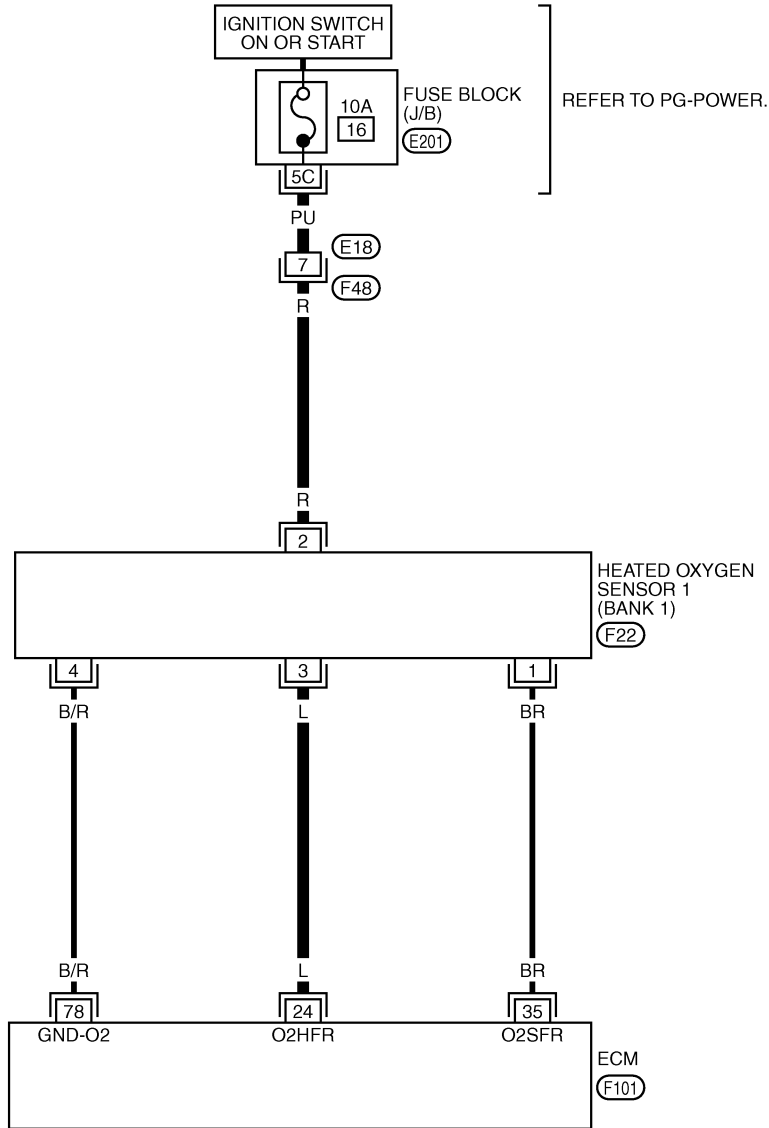

REFER TO THE FOLLOWING.
(E201) - FUSE BLOCK-JUNCTION BOX (J/B)

TBWM0283E

DTC P0031, P0032, P0051, P0052 HO2S1 HEATER

[VQ35DE]

Specification data are reference values and are measured between each terminal and ground.
Pulse signal is measured by CONSULT-II.

CAUTION:

Do not use ECM ground terminals when measuring input/output voltage. Doing so may result in damage to the ECM's transistor. Use a ground other than ECM terminals, such as the ground.

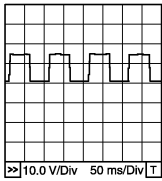
TER-MINAL NO.	WIRE COLOR	ITEM	CONDITION	DATA (DC Voltage)
24	L	Heated oxygen sensor 1 heater (bank 1)	<p>[Engine is running]</p> <ul style="list-style-type: none"> ● Warm-up condition ● Engine speed is below 3,600 rpm 	<p>Approximately 8V★</p>  <p style="text-align: right; font-size: small;">PBIB0519E</p>
			<p>[Engine is running]</p> <ul style="list-style-type: none"> ● Engine speed is above 3,600 rpm 	<p>BATTERY VOLTAGE (11 - 14V)</p>

★: Average voltage for pulse signal (Actual pulse signal can be confirmed by oscilloscope.)

DTC P0031, P0032, P0051, P0052 HO2S1 HEATER

[VQ35DE]

BANK 2

EC-O2H1B2-01

— : DETECTABLE LINE FOR DTC
 — : NON-DETECTABLE LINE FOR DTC

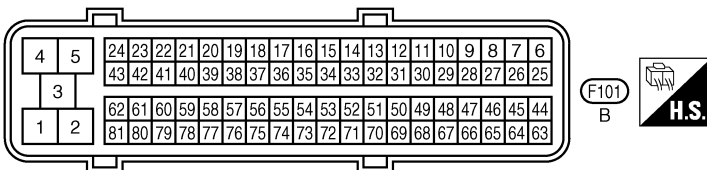
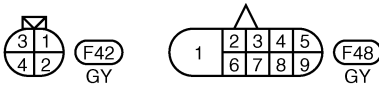
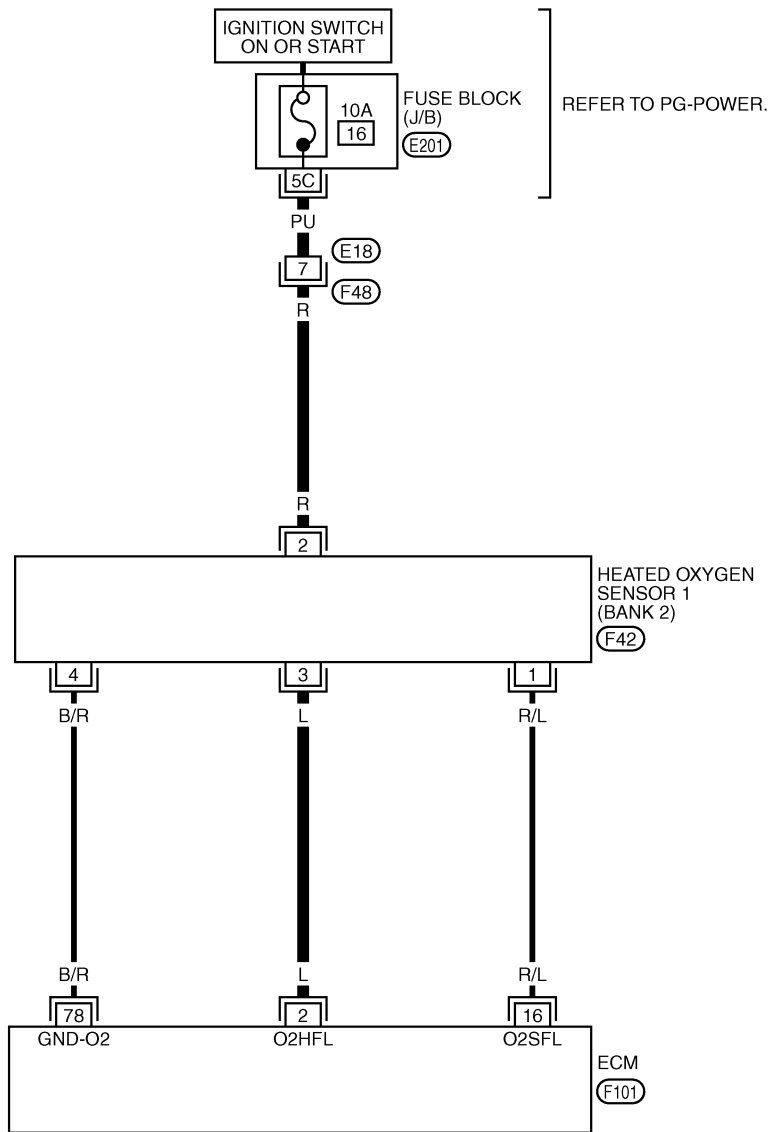

REFER TO THE FOLLOWING.
 (E201) - FUSE BLOCK-JUNCTION BOX (J/B)

TBWM0284E

DTC P0031, P0032, P0051, P0052 HO2S1 HEATER

[VQ35DE]

Specification data are reference values and are measured between each terminal and ground.
Pulse signal is measured by CONSULT-II.

CAUTION:

Do not use ECM ground terminals when measuring input/output voltage. Doing so may result in damage to the ECM's transistor. Use a ground other than ECM terminals, such as the ground.

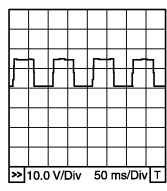
TER-MINAL NO.	WIRE COLOR	ITEM	CONDITION	DATA (DC Voltage)
2	L	Heated oxygen sensor 1 heater (bank 2)	[Engine is running] <ul style="list-style-type: none"> ● Warm-up condition ● Engine speed is below 3,600 rpm 	Approximately 8V★  PBIB0519E
			[Engine is running] <ul style="list-style-type: none"> ● Engine speed is above 3,600 rpm 	BATTERY VOLTAGE (11 - 14V)

★: Average voltage for pulse signal (Actual pulse signal can be confirmed by oscilloscope.)

Diagnostic Procedure

ABS006LO

1. CHECK GROUND CONNECTIONS

1. Turn ignition switch OFF.
2. Loosen and retighten ground three screws on the body. Refer to [EC-141, "Ground Inspection"](#) .

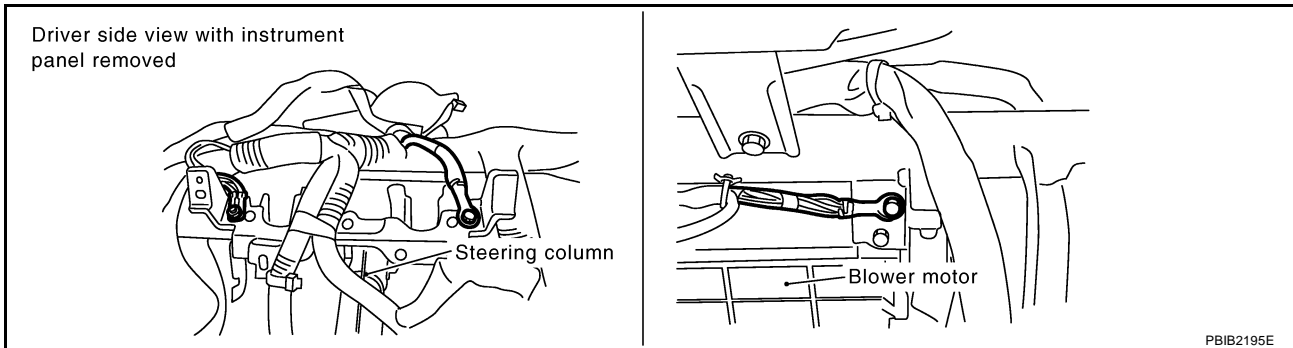

PBIB2195E

OK or NG

- OK >> GO TO 2.
 NG >> Repair or replace ground connections.

2. CHECK HO2S1 POWER SUPPLY CIRCUIT

1. Disconnect heated oxygen sensor 1 harness connector.

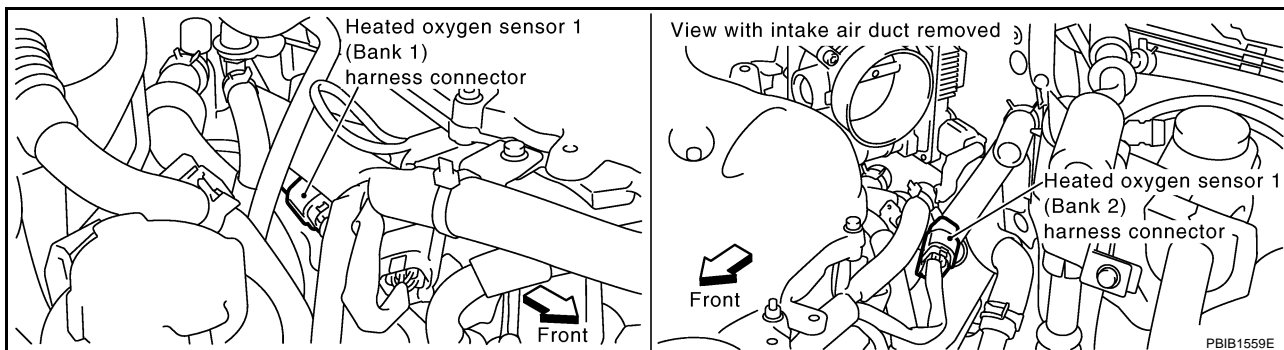

2. Turn ignition switch ON.
3. Check voltage between HO2S1 terminal 2 and ground with CONSULT-II or tester.

Voltage: Battery voltage

OK or NG

- OK >> GO TO 4.
- NG >> GO TO 3.

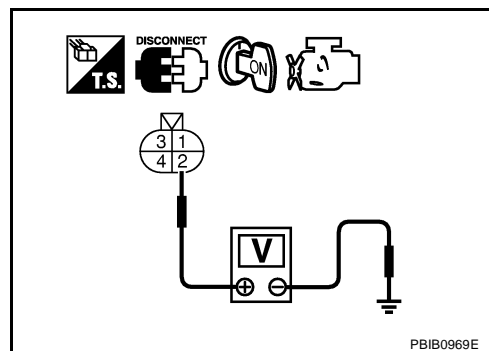

3. DETECT MALFUNCTIONING PART

Check the following.

- Harness connectors E18, F48
- Fuse block (J/B) connector E201
- 10A fuse
- Harness for open or short between heated oxygen sensor 1 and fuse

>> Repair harness or connectors.

4. CHECK HO2S1 OUTPUT SIGNAL CIRCUIT FOR OPEN AND SHORT

1. Turn ignition switch OFF.
2. Disconnect ECM harness connector.
3. Check harness continuity between ECM terminal and HO2S1 terminal as follows. Refer to Wiring Diagram.

DTC	Terminals		Bank
	ECM	Sensor	
P0031, P0032	24	3	1
P0051, P0052	2	3	2

Continuity should exist.

4. Also check harness for short to ground and short to power.

OK or NG

- OK >> GO TO 5.
- NG >> Repair open circuit or short to ground or short to power in harness or connectors.

5. CHECK HEATED OXYGEN SENSOR 1 HEATER

Refer to [EC-156, "Component Inspection"](#) .

OK or NG

- OK >> GO TO 6.
- NG >> Replace malfunctioning heated oxygen sensor 1.

6. CHECK INTERMITTENT INCIDENT

Refer to [EC-135, "TROUBLE DIAGNOSIS FOR INTERMITTENT INCIDENT"](#) .

>> INSPECTION END

Component Inspection HEATED OXYGEN SENSOR 1 HEATER

ABS006LP

1. Check resistance between HO2S1 terminals as follows.

Terminal No.	Resistance
2 and 3	3.3 - 4.0 Ω at 25°C (77°F)
1 and 2, 3, 4	$\infty \Omega$
4 and 1, 2, 3	(Continuity should not exist)

2. If NG, replace heated oxygen sensor 1.

CAUTION:

- Discard any heated oxygen sensor which has been dropped from a height of more than 0.5 m (19.7 in) onto a hard surface such as a concrete floor; use a new one.
- Before installing new oxygen sensor, clean exhaust system threads using Oxygen Sensor Thread Cleaner tool J-43897-18 or J-43897-12 and approved anti-seize lubricant.

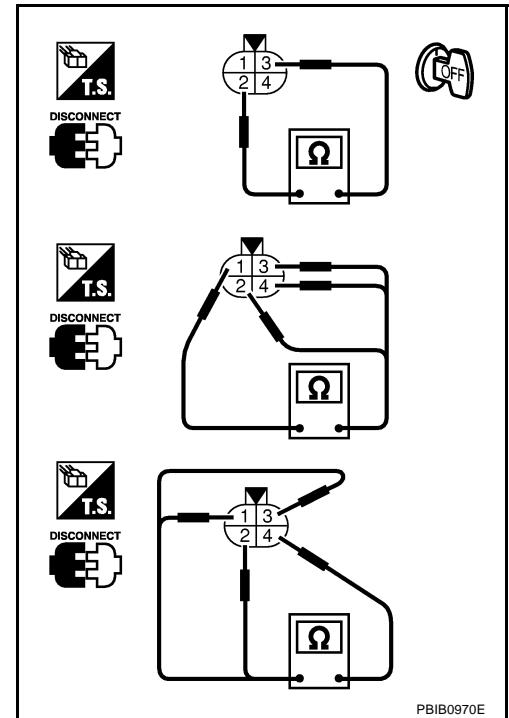

PBIB0970E

Removal and Installation HEATED OXYGEN SENSOR 1

ABS006LQ

Refer to [EM-26, "EXHAUST MANIFOLD AND THREE WAY CATALYST"](#) .

DTC P0037, P0038, P0057, P0058 HO2S2 HEATER

[VQ35DE]

DTC P0037, P0038, P0057, P0058 HO2S2 HEATER

PFP:226A0

Description SYSTEM DESCRIPTION

ABS006LR

Sensor	Input signal to ECM	ECM function	Actuator
Camshaft position sensor (PHASE) Crankshaft position sensor (POS)	Engine speed	Heated oxygen sensor 2 heater control	Heated oxygen sensor 2 heater
Engine coolant temperature sensor	Engine coolant temperature		
Mass air flow sensor	Amount of intake air		

The ECM performs ON/OFF control of the heated oxygen sensor 2 heater corresponding to the engine speed, amount of intake air and engine coolant temperature.

OPERATION

Engine speed rpm	Heated oxygen sensor 2 heater
Above 3,600	OFF
Below 3,600 rpm after the following conditions are met. <ul style="list-style-type: none"> ● Engine: After warming up ● Keeping the engine speed between 3,500 and 4,000 rpm for 1 minute and at idle for 1 minute under no load 	ON

CONSULT-II Reference Value in Data Monitor Mode

ABS006LS

Specification data are reference values.

MONITOR ITEM	CONDITION	SPECIFICATION
HO2S2 HTR (B1) HO2S2 HTR (B2)	<ul style="list-style-type: none"> ● Engine speed is below 3,600 rpm after the following conditions are met. <ul style="list-style-type: none"> – Engine: After warming up – Keeping the engine speed between 3,500 and 4,000 rpm for 1 minute and at idle for 1 minute under no load 	ON
	<ul style="list-style-type: none"> ● Engine speed: Above 3,600 rpm 	OFF

On Board Diagnosis Logic

ABS006LT

DTC No.	Trouble diagnosis name	DTC detecting condition	Possible cause
P0037 0037 (Bank 1)	Heated oxygen sensor 2 heater control circuit low	The current amperage in the heated oxygen sensor 2 heater circuit is out of the normal range. (An excessively low voltage signal is sent to ECM through the heated oxygen sensor 2 heater.)	<ul style="list-style-type: none"> ● Harness or connectors (The heated oxygen sensor 2 heater circuit is open or shorted.) ● Heater oxygen sensor 2 heater
P0057 0057 (Bank 2)			
P0038 0038 (Bank 1)	Heated oxygen sensor 2 heater control circuit high	The current amperage in the heated oxygen sensor 2 heater circuit is out of the normal range. (An excessively high voltage signal is sent to ECM through the heated oxygen sensor 2 heater.)	<ul style="list-style-type: none"> ● Harness or connectors (The heated oxygen sensor 2 heater circuit is shorted.) ● Heater oxygen sensor 2 heater
P0058 0058 (Bank 2)			

DTC Confirmation Procedure**NOTE:**

If DTC Confirmation Procedure has been previously conducted, always turn ignition switch OFF and wait at least 10 seconds before conducting the next test.

TESTING CONDITION:

Before performing the following procedure, confirm that battery voltage is between 11V and 16V at idle.

 **WITH CONSULT-II**

1. Turn ignition switch ON and select "DATA MONITOR" mode with CONSULT-II.
2. Start engine and warm it up to the normal operating temperature.
3. Turn ignition switch OFF and wait at least 10 seconds.
4. Start the engine and keep the engine speed between 3,500 rpm and 4,000 rpm for at least 1 minute under no load.
5. Let engine idle for 1 minute.
6. If 1st trip DTC is detected, go to [EC-162, "Diagnostic Procedure"](#)

DATA MONITOR	
MONITOR	NO DTC
COOLAN TEMP/S	XXX °C
VHCL SPEED SE	XXX km/h

SEF176Y

 **WITH GST**

Follow the procedure "WITH CONSULT-II" above.

DTC P0037, P0038, P0057, P0058 HO2S2 HEATER

[VQ35DE]

ABS006LV

Wiring Diagram BANK 1

EC-O2H2B1-01

— : DETECTABLE LINE FOR DTC
 - - - : NON-DETECTABLE LINE FOR DTC

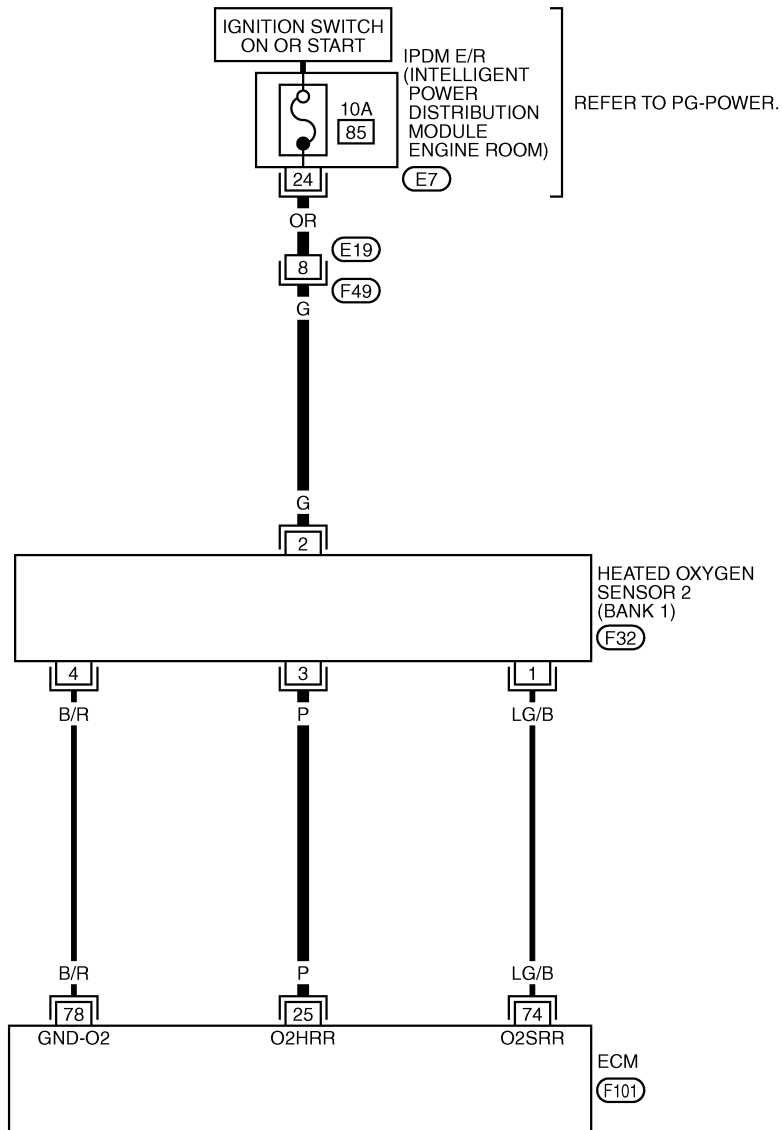

23	22	21	20	19	18	17		
32	31	30	29	28	27	26	25	24

(E7)
GY



3	1
4	2

(F32)
B

1	2	3	4
5	6	7	8

(F49)
B

4	5	24	23	22	21	20	19	18	17	16	15	14	13	12	11	10	9	8	7	6																			
3	32	31	30	29	28	27	26	25	24	43	42	41	40	39	38	37	36	35	34	33	32	31	30	29	28	27	26	25											
1	2	62	61	60	59	58	57	56	55	54	53	52	51	50	49	48	47	46	45	44	81	80	79	78	77	76	75	74	73	72	71	70	69	68	67	66	65	64	63

(F101)
B



TBWM0285E

DTC P0037, P0038, P0057, P0058 HO2S2 HEATER

[VQ35DE]

Specification data are reference values and are measured between each terminal and ground.

CAUTION:

Do not use ECM ground terminals when measuring input/output voltage. Doing so may result in damage to the ECM's transistor. Use a ground other than ECM terminals, such as the ground.

TER-MINAL NO.	WIRE COLOR	ITEM	CONDITION	DATA (DC Voltage)
25	P	Heated oxygen sensor 2 heater (bank 1)	[Engine is running] <ul style="list-style-type: none"> ● Engine speed is below 3,600 rpm after the following conditions are met <ul style="list-style-type: none"> - Engine: after warming up - Keeping the engine speed between 3,500 and 4,000 rpm for 1 minute and at idle for 1 minute under no load 	0 - 1.0V
			[Ignition switch: ON] <ul style="list-style-type: none"> ● Engine stopped [Engine is running] <ul style="list-style-type: none"> ● Engine speed is above 3,600 rpm 	BATTERY VOLTAGE (11 - 14V)

DTC P0037, P0038, P0057, P0058 HO2S2 HEATER

[VQ35DE]

BANK 2

EC-O2H2B2-01

— : DETECTABLE LINE FOR DTC
 — : NON-DETECTABLE LINE FOR DTC

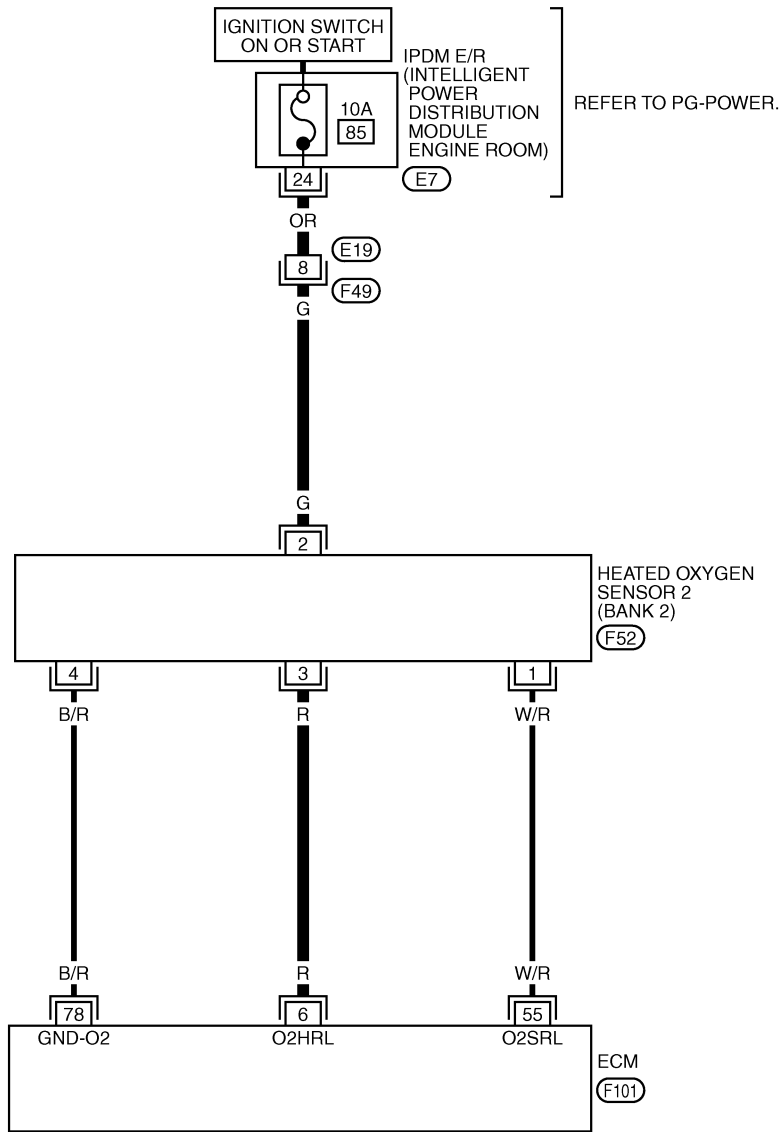

23	22	21	20	19	18	17		
32	31	30	29	28	27	26	25	24

(E7) GY

H.S.

1	2	3	4
5	6	7	8

(F49) B

3	1
4	2

(F52) GY

4	5	24	23	22	21	20	19	18	17	16	15	14	13	12	11	10	9	8	7	6
3		43	42	41	40	39	38	37	36	35	34	33	32	31	30	29	28	27	26	25
1	2	62	61	60	59	58	57	56	55	54	53	52	51	50	49	48	47	46	45	44
		81	80	79	78	77	76	75	74	73	72	71	70	69	68	67	66	65	64	63

(F101) B

H.S.

TBWM0286E

DTC P0037, P0038, P0057, P0058 HO2S2 HEATER

[VQ35DE]

Specification data are reference values and are measured between each terminal and ground.

CAUTION:

Do not use ECM ground terminals when measuring input/output voltage. Doing so may result in damage to the ECM's transistor. Use a ground other than ECM terminals, such as the ground.

TER-MINAL NO.	WIRE COLOR	ITEM	CONDITION	DATA (DC Voltage)
6	R	Heated oxygen sensor 2 heater (bank 2)	[Engine is running] <ul style="list-style-type: none"> ● Engine speed is below 3,600 rpm after the following conditions are met <ul style="list-style-type: none"> - Engine: after warming up - Keeping the engine speed between 3,500 and 4,000 rpm for 1 minute and at idle for 1 minute under no load 	0 - 1.0V
			[Ignition switch: ON] <ul style="list-style-type: none"> ● Engine stopped [Engine is running] <ul style="list-style-type: none"> ● Engine speed is above 3,600 rpm 	BATTERY VOLTAGE (11 - 14V)

Diagnostic Procedure

ABS00CG0

1. CHECK GROUND CONNECTIONS

1. Turn ignition switch OFF.
2. Loosen and retighten ground three screws on the body. Refer to [EC-141, "Ground Inspection"](#).

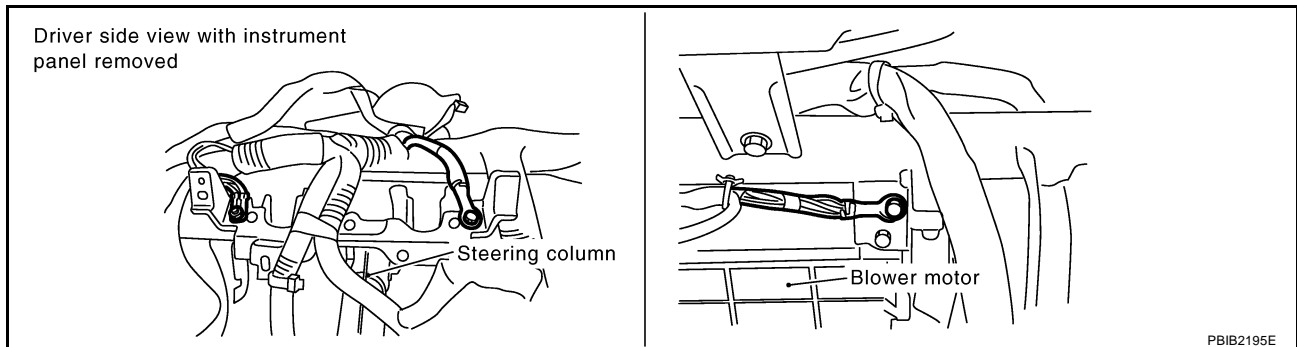

OK or NG

- OK >> GO TO 2.
- NG >> Repair or replace ground connections.

2. CHECK HO2S2 POWER SUPPLY CIRCUIT

1. Disconnect heated oxygen sensor 2 harness connector.
2. Turn ignition switch ON.

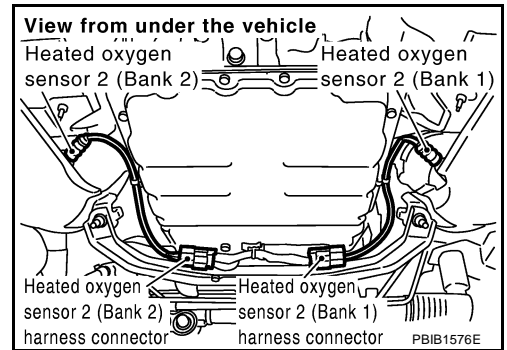

3. Check voltage between HO2S2 terminal 2 and ground with CONSULT-II or tester.

Voltage: Battery voltage

OK or NG

- OK >> GO TO 4.
 NG >> GO TO 3.

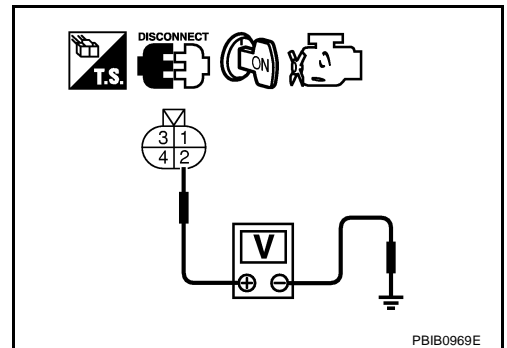

3. DETECT MALFUNCTIONING PART

Check the following.

- Harness connectors E19, F49
- IPDM E/R connector E7
- 10A fuse
- Harness for open or short between heated oxygen sensor 2 and fuse

>> Repair harness or connectors.

4. CHECK HO2S2 OUTPUT SIGNAL CIRCUIT FOR OPEN AND SHORT

1. Turn ignition switch OFF.
2. Disconnect ECM harness connector.
3. Check harness continuity between ECM terminal and HO2S2 terminal as follows. Refer to Wiring Diagram.

DTC	Terminals		Bank
	ECM	Sensor	
P0037, P0038	25	3	1
P0057, P0058	6	3	2

Continuity should exist.

4. Also check harness for short to ground and short to power.

OK or NG

- OK >> GO TO 5.
 NG >> Repair open circuit or short to ground or short to power in harness or connectors.

5. CHECK HEATED OXYGEN SENSOR 2 HEATER

Refer to [EC-164, "Component Inspection"](#) .

OK or NG

- OK >> GO TO 6.
- NG >> Replace malfunctioning heated oxygen sensor 2.

6. CHECK INTERMITTENT INCIDENT

Refer to [EC-135, "TROUBLE DIAGNOSIS FOR INTERMITTENT INCIDENT"](#) .

>> INSPECTION END

Component Inspection HEATED OXYGEN SENSOR 2 HEATER

ABS006LX

1. Check resistance between HO2S2 terminals as follows.

Terminal No.	Resistance
2 and 3	5.0 - 7.0 Ω at 25°C (77°F)
1 and 2, 3, 4	$\infty \Omega$
4 and 1, 2, 3	(Continuity should not exist)

2. If NG, replace heated oxygen sensor 2.

CAUTION:

- Discard any heated oxygen sensor which has been dropped from a height of more than 0.5 m (19.7 in) onto a hard surface such as a concrete floor; use a new one.
- Before installing new oxygen sensor, clean exhaust system threads using Oxygen Sensor Thread Cleaner tool J-43897-18 or J-43897-12 and approved anti-seize lubricant.

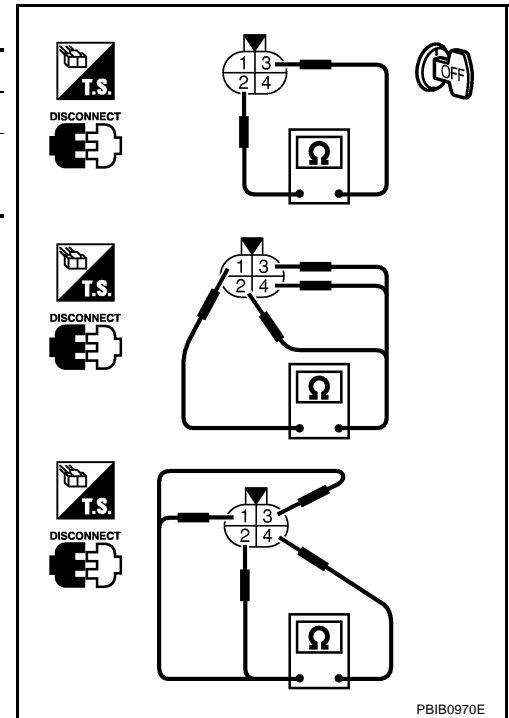

PBIB0970E

Removal and Installation HEATED OXYGEN SENSOR 2

ABS006LY

Refer to [EM-26, "EXHAUST MANIFOLD AND THREE WAY CATALYST"](#) .

DTC P0101 MAF SENSOR

PF2:22680

Component Description

ABS006LZ

The mass air flow sensor is placed in the stream of intake air. It measures the intake flow rate by measuring a part of the entire intake flow. The mass air flow sensor controls the temperature of the hot wire to a certain amount. The heat generated by the hot wire is reduced as the intake air flows around it. The more air, the greater the heat loss.

Therefore, the electric current supplied to hot wire is changed to maintain the temperature of the hot wire as air flow increases. The ECM detects the air flow by means of this current change.

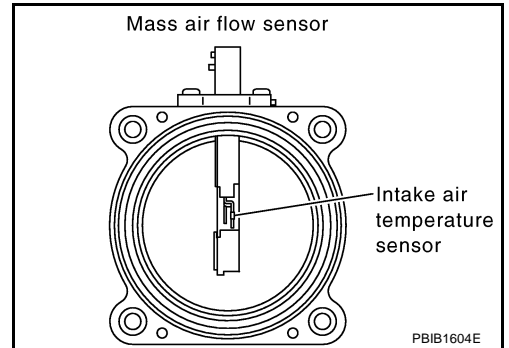

CONSULT-II Reference Value in Data Monitor Mode

ABS006M0

Specification data are reference values.

MONITOR ITEM	CONDITION		SPECIFICATION
MAS A/F SE-B1	See EC-131 , "TROUBLE DIAGNOSIS - SPECIFICATION VALUE".		
CAL/LD VALUE	<ul style="list-style-type: none"> ● Engine: After warming up ● Shift lever: P or N ● Air conditioner switch: OFF ● No-load 	Idle	5% - 35%
		2,500 rpm	5% - 35%
MASS AIRFLOW	<ul style="list-style-type: none"> ● Engine: After warming up ● Shift lever: P or N ● Air conditioner switch: OFF ● No-load 	Idle	2.0 - 6.0 g-m/s
		2,500 rpm	7.0 - 20.0 g-m/s

On Board Diagnosis Logic

ABS006M1

This self-diagnosis has the one trip detection logic.

DTC No.	Trouble diagnosis name	DTC detecting condition		Possible cause
P0101 0101	Mass air flow sensor circuit range/performance problem	A)	A high voltage from the sensor is sent to ECM under light load driving condition.	<ul style="list-style-type: none"> ● Harness or connectors (The sensor circuit is open or shorted.) ● Mass air flow sensor
		B)	A low voltage from the sensor is sent to ECM under heavy load driving condition.	<ul style="list-style-type: none"> ● Harness or connectors (The sensor circuit is open or shorted.) ● Intake air leaks ● Mass air flow sensor

DTC Confirmation Procedure

Perform **PROCEDURE FOR MALFUNCTION A** first.

If the DTC cannot be confirmed, perform **PROCEDURE FOR MALFUNCTION B**.

NOTE:

If DTC Confirmation Procedure has been previously conducted, always turn ignition switch OFF and wait at least 10 seconds before conducting the next test.

PROCEDURE FOR MALFUNCTION A

NOTE:

If engine will not start or stops soon, wait at least 10 seconds with engine stopped (Ignition switch ON) instead of running engine at idle speed.

 **With CONSULT-II**

1. Turn ignition switch ON.
2. Select "DATA MONITOR" mode with CONSULT-II.
3. Start engine and warm it up to normal operating temperature.
4. Run engine for at least 10 seconds at idle speed.
5. If DTC is detected, go to [EC-169, "Diagnostic Procedure"](#) .

DATA MONITOR	
MONITOR	NO DTC
ENG SPEED	XXX rpm
COOLANT TEMP/S	XXX °C

SEF174Y

 **With GST**

Follow the procedure "With CONSULT-II" above.

PROCEDURE FOR MALFUNCTION B

CAUTION:

Always drive vehicle at a safe speed.

 **With CONSULT-II**

1. Turn ignition switch ON.
2. Start engine and warm it up to normal operating temperature.
If engine cannot be started, go to [EC-169, "Diagnostic Procedure"](#) .
3. Select "DATA MONITOR" mode with CONSULT-II.
4. Check the voltage of "MAS A/F SE-B1" with "DATA MONITOR".
5. Increases engine speed to about 4,000 rpm.
6. Monitor the linear voltage rise in response to engine speed increases.
If NG, go to [EC-169, "Diagnostic Procedure"](#) .
If OK, go to following step.

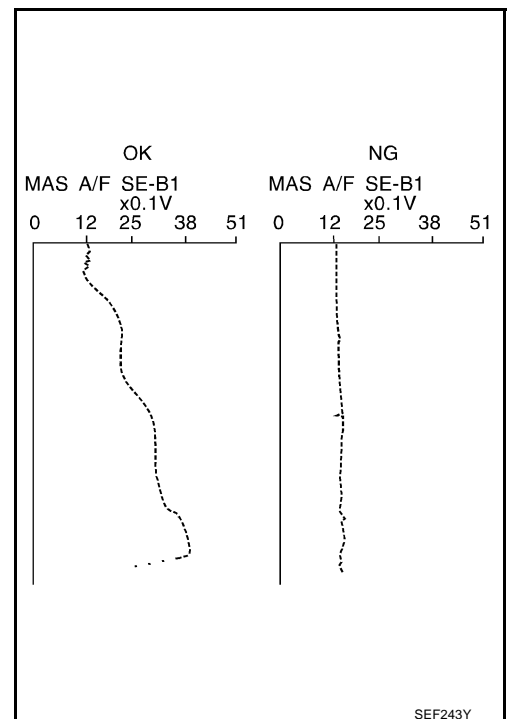

DTC P0101 MAF SENSOR

[VQ35DE]

7. Maintain the following conditions for at least 10 consecutive seconds.

ENG SPEED	More than 2,000 rpm
THRTL SEN 1	More than 3V
THRTL SEN 2	More than 3V
Selector lever	Suitable position
Driving location	Driving vehicle uphill (Increased engine load) will help maintain the driving conditions required for this test.

DATA MONITOR	
MONITOR	NO DTC
ENG SPEED	XXX rpm
VHCL SPEED SE	XXX km/h
THRTL SEN 1	XXX V
THRTL SEN 2	XXX V

PBIB0199E

8. If DTC is detected, go to [EC-169, "Diagnostic Procedure"](#) .

Overall Function Check PROCEDURE FOR MALFUNCTION B

ABS006M3

Use this procedure to check the overall function of the mass air flow sensor circuit. During this check, a DTC might not be confirmed.

With GST

1. Start engine and warm it up to normal operating temperature.
2. Select MODE 1 with GST.
3. Check the mass air flow sensor signal with MODE 1.
4. Check for linear mass air flow sensor signal value rise in response to increases to about 4,000 rpm in engine speed.
5. If NG, go to [EC-169, "Diagnostic Procedure"](#) .

CALC LOAD	20%
COOLANT TEMP	95°C
SHORT FT #1	2%
LONG FT #1	0%
SHORT FT #2	4%
LONG FT #2	0%
ENGINE SPD	2637RPM
VEHICLE SPD	0MPH
IGN ADVANCE	41.0°
INTAKE AIR	41°C
MAF	14.1gm/sec
THROTTLE POS	3%

SEF534P

DTC P0101 MAF SENSOR

[VQ35DE]

ABS006M4

Wiring Diagram

EC-MAFS-01

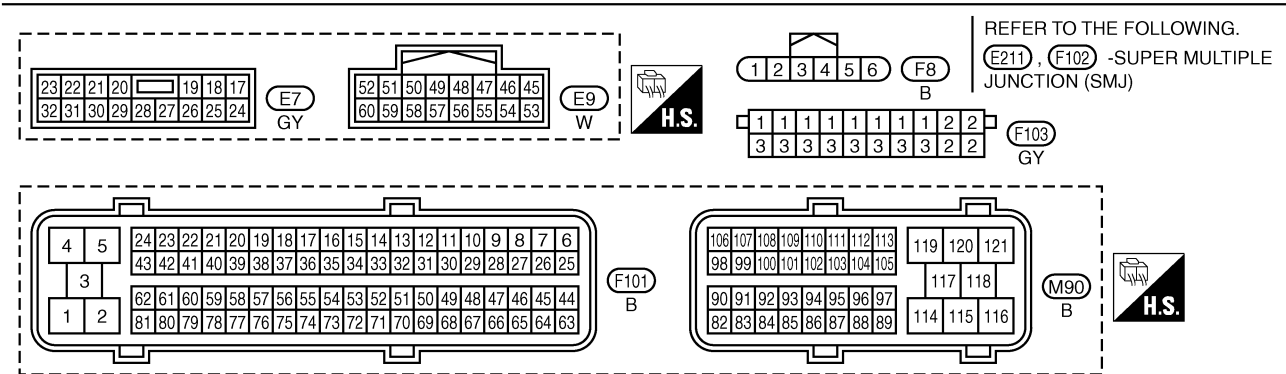
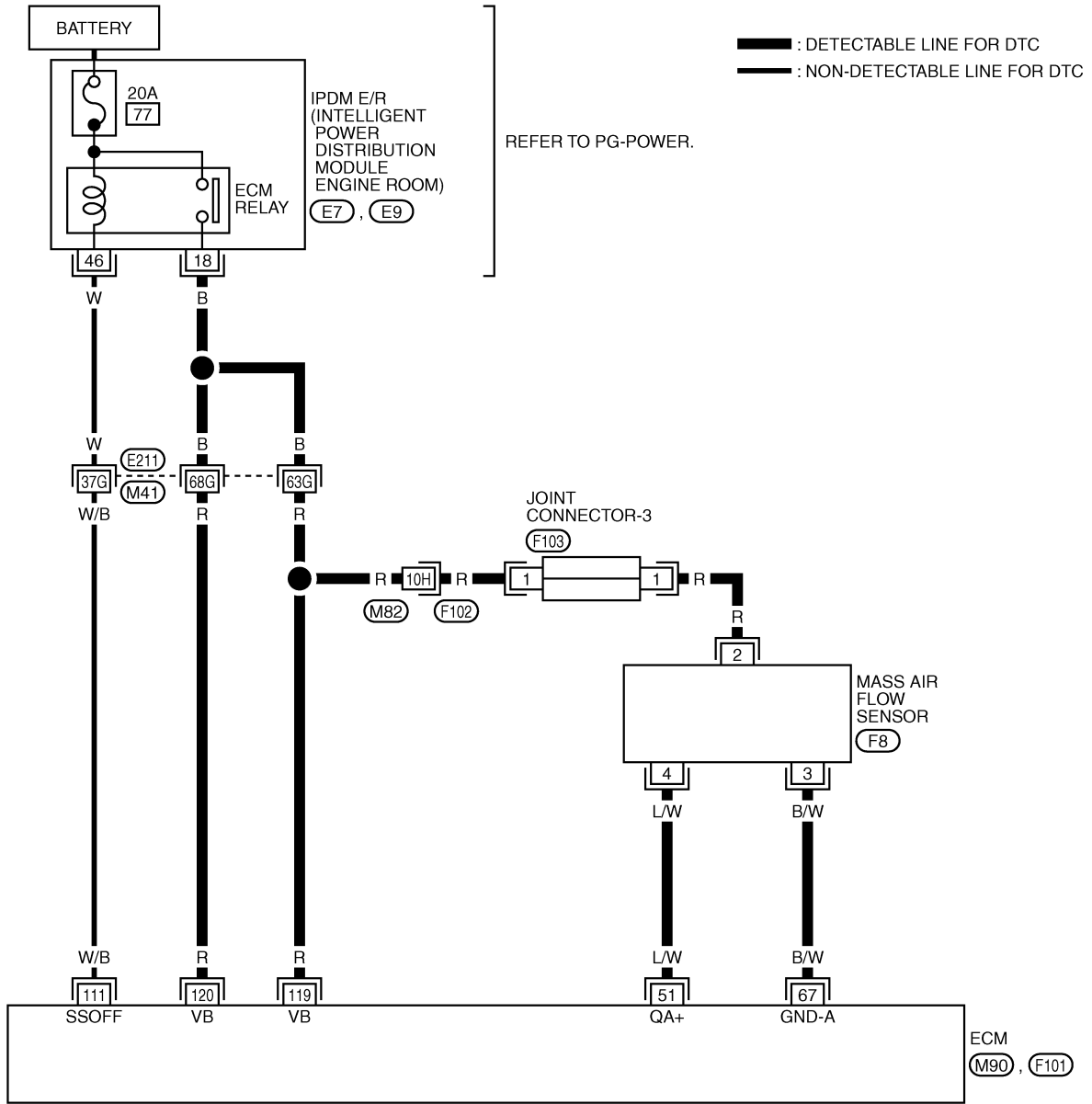

TBWM0287E

DTC P0101 MAF SENSOR

[VQ35DE]

Specification data are reference values and are measured between each terminal and ground.

CAUTION:

Do not use ECM ground terminals when measuring input/output voltage. Doing so may result in damage to the ECM's transistor. Use a ground other than ECM terminals, such as the ground.

TER-MINAL NO.	WIRE COLOR	ITEM	CONDITION	DATA (DC Voltage)
51	L/W	Mass air flow sensor	[Engine is running] ● Warm-up condition ● Idle speed	0.9 - 1.2V
			[Engine is running] ● Warm-up condition ● Engine speed is 2,500 rpm	1.6 - 1.9V
67	B/W	Sensor ground (Mass air flow sensor)	[Engine is running] ● Warm-up condition ● Idle speed	Approximately 0V
111	W/B	ECM relay (Self shut-off)	[Engine is running] [Ignition switch: OFF] ● For a few seconds after turning ignition switch OFF	0 - 1.5V
			[Ignition switch: OFF] ● More than a few seconds after turning ignition switch OFF	BATTERY VOLTAGE (11 - 14V)
119 120	R R	Power supply for ECM	[Ignition switch: ON]	BATTERY VOLTAGE (11 - 14V)

Diagnostic Procedure

ABS00CGP

1. INSPECTION START

Which malfunction (A or B) is duplicated?

A or B

- A >> GO TO 3.
- B >> GO TO 2.

2. CHECK INTAKE SYSTEM

Check the following for connection.

- Air duct
- Vacuum hoses
- Intake air passage between air duct and intake manifold

OK or NG

- OK >> GO TO 3.
- NG >> Reconnect the parts.

3. CHECK GROUND CONNECTIONS

1. Turn ignition switch OFF.
2. Loosen and retighten ground three screws on the body. Refer to [EC-141, "Ground Inspection"](#).

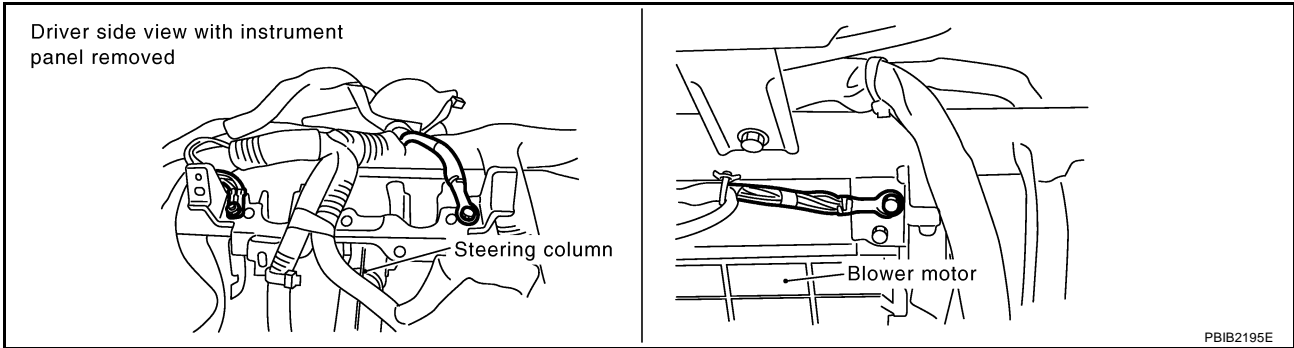

OK or NG

- OK >> GO TO 4.
- NG >> Repair or replace ground connections.

4. CHECK MAF SENSOR POWER SUPPLY CIRCUIT

1. Disconnect mass air flow (MAF) sensor harness connector.
2. Turn ignition switch ON.

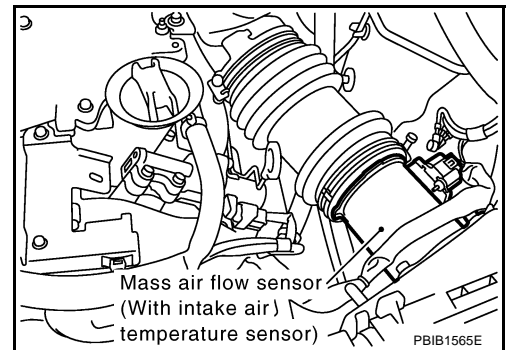

3. Check voltage between MAF sensor terminal 2 and ground with CONSULT-II or tester.

Voltage: Battery voltage

OK or NG

- OK >> GO TO 6.
- NG >> GO TO 5.

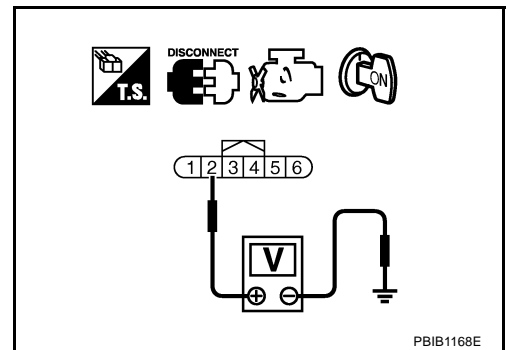

5. DETECT MALFUNCTIONING PART

Check the following.

- Harness connectors E211, M41
- Harness connectors M82, F102
- Joint connector-3
- Harness for open or short between IPDM E/R and mass air flow sensor
- Harness for open or short between mass air flow sensor and ECM

>> Repair harness or connectors.

6. CHECK MAF SENSOR GROUND CIRCUIT FOR OPEN AND SHORT

1. Turn ignition switch OFF.
2. Disconnect ECM harness connector.
3. Check harness continuity between MAF sensor terminal 3 and ECM terminal 67.
Refer to Wiring Diagram.

Continuity should exist.

4. Also check harness for short to ground and short to power.

OK or NG

OK >> GO TO 7.

NG >> Repair open circuit or short to ground or short to power in harness or connectors.

7. CHECK MAF SENSOR INPUT SIGNAL CIRCUIT FOR OPEN AND SHORT

1. Check harness continuity between MAF sensor terminal 4 and ECM terminal 51.
Refer to Wiring Diagram.

Continuity should exist.

2. Also check harness for short to ground and short to power.

OK or NG

OK >> GO TO 8.

NG >> Repair open circuit or short to ground or short to power in harness or connectors.

8. CHECK MASS AIR FLOW SENSOR

Refer to [EC-172, "Component Inspection"](#) .

OK or NG

OK >> GO TO 9.

NG >> Replace mass air flow sensor.

9. CHECK INTERMITTENT INCIDENT

Refer to [EC-135, "TROUBLE DIAGNOSIS FOR INTERMITTENT INCIDENT"](#) .

>> INSPECTION END

A

EC

C

D

E

F

G

H

I

J

K

L

M

Component Inspection MASS AIR FLOW SENSOR

1. Reconnect all harness connectors disconnected.
2. Start engine and warm it up to normal operating temperature.
3. Check voltage between ECM terminal 51 (Mass air flow sensor signal) and ground.

Condition	Voltage V
Ignition switch ON (Engine stopped.)	Approx. 0.4
Idle (Engine is warmed-up to normal operating temperature.)	0.9 - 1.2
2,500 rpm (Engine is warmed-up to normal operating temperature.)	1.6 - 1.9
Idle to about 4,000 rpm*	0.9 - 1.2 to Approx. 2.4

*: Check for linear voltage rise in response to engine being increased to about 4,000 rpm.

4. If the voltage is out of specification, proceed the following.
 - Turn ignition switch OFF.
 - Disconnect mass air flow sensor harness connector and reconnect it again.
 - Perform steps 2 and 3 again.
5. If NG, remove mass air flow sensor from air duct. Check hot wire for damage or dust.
6. If NG, clean or replace mass air flow sensor.

Removal and Installation MASS AIR FLOW SENSOR

Refer to [EM-17, "AIR CLEANER AND AIR DUCT"](#) .

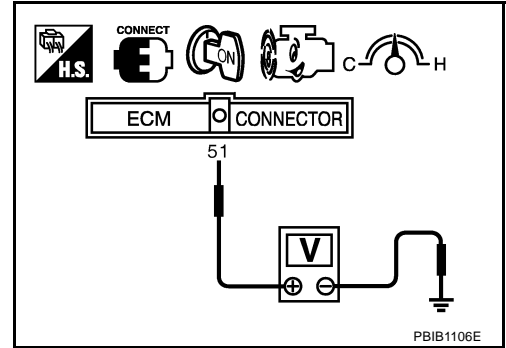

DTC P0102, P0103 MAF SENSOR

PF2:22680

Component Description

ABS006M8

The mass air flow sensor is placed in the stream of intake air. It measures the intake flow rate by measuring a part of the entire intake flow. The mass air flow sensor controls the temperature of the hot wire to a certain amount. The heat generated by the hot wire is reduced as the intake air flows around it. The more air, the greater the heat loss.

Therefore, electric current supplied to hot wire is changed to maintain the temperature of the hot wire as air flow increases. The ECM detects the air flow by means of this current change.

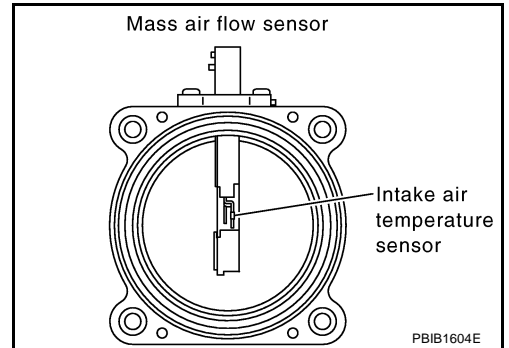

CONSULT-II Reference Value in Data Monitor Mode

ABS006M9

Specification data are reference values.

MONITOR ITEM	CONDITION		SPECIFICATION
MAS A/F SE-B1	See EC-131 , "TROUBLE DIAGNOSIS - SPECIFICATION VALUE".		
CAL/LD VALUE	<ul style="list-style-type: none"> ● Engine: After warming up ● Shift lever: P or N ● Air conditioner switch: OFF ● No-load 	Idle	5% - 35%
		2,500 rpm	5% - 35%
MASS AIRFLOW	<ul style="list-style-type: none"> ● Engine: After warming up ● Shift lever: P or N ● Air conditioner switch: OFF ● No-load 	Idle	2.0 - 6.0 g-m/s
		2,500 rpm	7.0 - 20.0 g-m/s

On Board Diagnosis Logic

ABS006MA

These self-diagnoses have the one trip detection logic.

DTC No.	Trouble diagnosis name	DTC detecting condition	Possible cause
P0102 0102	Mass air flow sensor circuit low input	An excessively low voltage from the sensor is sent to ECM.	<ul style="list-style-type: none"> ● Harness or connectors (The sensor circuit is open or shorted.) ● Intake air leaks ● Mass air flow sensor
P0103 0103	Mass air flow sensor circuit high input	An excessively high voltage from the sensor is sent to ECM.	<ul style="list-style-type: none"> ● Harness or connectors (The sensor circuit is open or shorted.) ● Mass air flow sensor

FAIL-SAFE MODE

When the malfunction is detected, the ECM enters fail-safe mode and the MIL lights up.

Detected items	Engine operating condition in fail-safe mode
Mass air flow sensor circuit	Engine speed will not rise more than 2,400 rpm due to the fuel cut.

DTC Confirmation Procedure

NOTE:

If DTC Confirmation Procedure has been previously conducted, always turn ignition switch OFF and wait at least 10 seconds before conducting the next test.

PROCEDURE FOR DTC P0102

With CONSULT-II

1. Turn ignition switch ON.
2. Select "DATA MONITOR" mode with CONSULT-II.
3. Start engine and wait at least 5 seconds.
4. If DTC is detected, go to [EC-176, "Diagnostic Procedure"](#) .

DATA MONITOR	
MONITOR	NO DTC
ENG SPEED	XXX rpm

SEF058Y

With GST

Follow the procedure "With CONSULT-II" above.

PROCEDURE FOR DTC P0103

With CONSULT-II

1. Turn ignition switch ON.
2. Select "DATA MONITOR" mode with CONSULT-II.
3. Wait at least 5 seconds.
4. If DTC is detected, go to [EC-176, "Diagnostic Procedure"](#) .
If DTC is not detected, go to next step.
5. Start engine and wait at least 5 seconds.
6. If DTC is detected, go to [EC-176, "Diagnostic Procedure"](#) .

DATA MONITOR	
MONITOR	NO DTC
ENG SPEED	XXX rpm

SEF058Y

With GST

Follow the procedure "With CONSULT-II" above.

DTC P0102, P0103 MAF SENSOR

[VQ35DE]

ABS006MC

Wiring Diagram

EC-MAFS-01

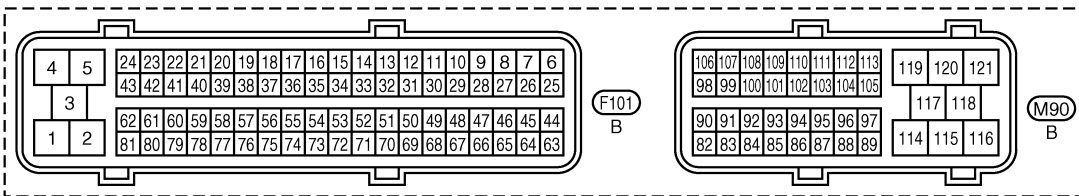
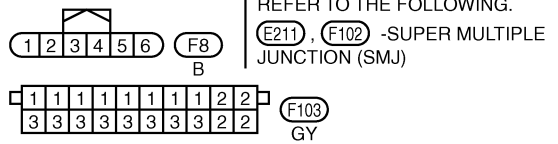
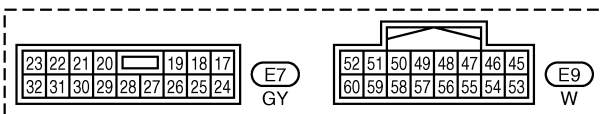
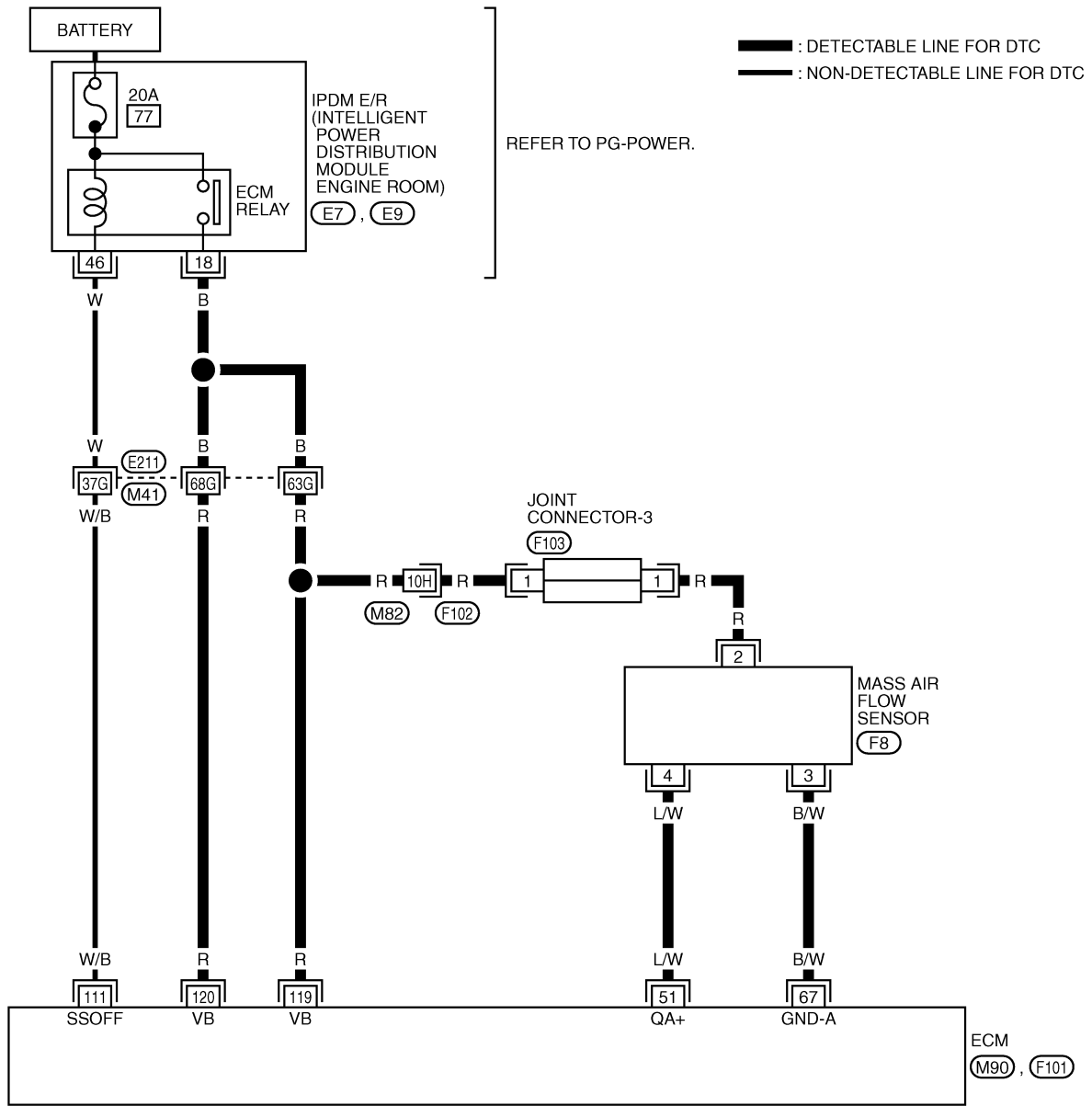

TBWM0287E

DTC P0102, P0103 MAF SENSOR

[VQ35DE]

Specification data are reference values and are measured between each terminal and ground.

CAUTION:

Do not use ECM ground terminals when measuring input/output voltage. Doing so may result in damage to the ECM's transistor. Use a ground other than ECM terminals, such as the ground.

TER-MINAL NO.	WIRE COLOR	ITEM	CONDITION	DATA (DC Voltage)
51	L/W	Mass air flow sensor	[Engine is running] <ul style="list-style-type: none"> ● Warm-up condition ● Idle speed 	0.9 - 1.2V
			[Engine is running] <ul style="list-style-type: none"> ● Warm-up condition ● Engine speed is 2,500 rpm 	1.6 - 1.9V
67	B/W	Sensor ground (Mass air flow sensor)	[Engine is running] <ul style="list-style-type: none"> ● Warm-up condition ● Idle speed 	Approximately 0V
111	W/B	ECM relay (Self shut-off)	[Engine is running] [Ignition switch: OFF] <ul style="list-style-type: none"> ● For a few seconds after turning ignition switch OFF 	0 - 1.5V
			[Ignition switch: OFF] <ul style="list-style-type: none"> ● More than a few seconds after turning ignition switch OFF 	BATTERY VOLTAGE (11 - 14V)
119 120	R R	Power supply for ECM	[Ignition switch: ON]	BATTERY VOLTAGE (11 - 14V)

Diagnostic Procedure

ABS00CG0

1. INSPECTION START

Which malfunction (P0102 or P0103) is duplicated?

P0102 or P0103

P0102 >> GO TO 2.

P0103 >> GO TO 3.

2. CHECK INTAKE SYSTEM

Check the following for connection.

- Air duct
- Vacuum hoses
- Intake air passage between air duct and intake manifold

OK or NG

OK >> GO TO 3.

NG >> Reconnect the parts.

3. CHECK GROUND CONNECTIONS

1. Turn ignition switch OFF.
2. Loosen and retighten ground three screws on the body. Refer to [EC-141, "Ground Inspection"](#).

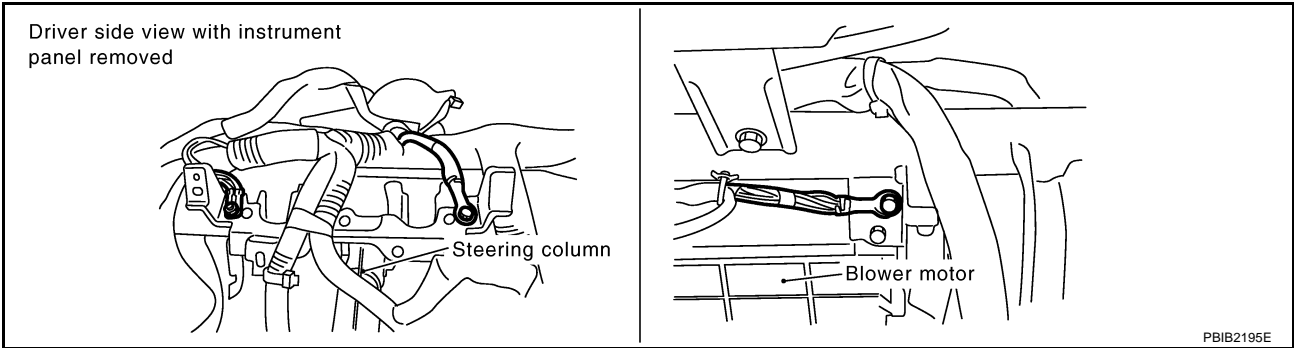

OK or NG

- OK >> GO TO 4.
- NG >> Repair or replace ground connections.

4. CHECK MAF SENSOR POWER SUPPLY CIRCUIT

1. Disconnect mass air flow (MAF) sensor harness connector.
2. Turn ignition switch ON.

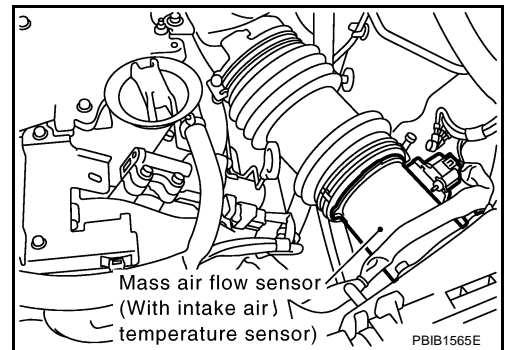

3. Check voltage between MAF sensor terminal 2 and ground with CONSULT-II or tester.

Voltage: Battery voltage

OK or NG

- OK >> GO TO 6.
- NG >> GO TO 5.

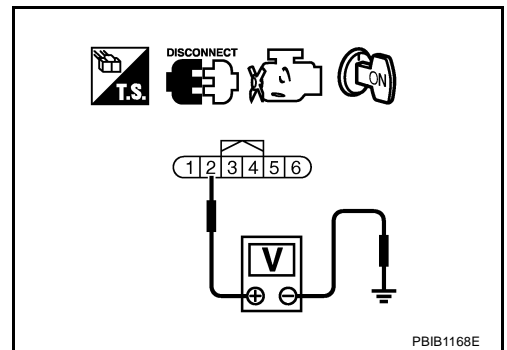

5. DETECT MALFUNCTIONING PART

Check the following.

- Harness connectors E211, M41
- Harness connectors M82, F102
- Joint connector-3
- Harness for open or short between IPDM E/R and mass air flow sensor
- Harness for open or short between mass air flow sensor and ECM

>> Repair harness or connectors.

6. CHECK MAF SENSOR GROUND CIRCUIT FOR OPEN AND SHORT

1. Turn ignition switch OFF.
2. Disconnect ECM harness connector.
3. Check harness continuity between MAF sensor terminal 3 and ECM terminal 67.
Refer to Wiring Diagram.

Continuity should exist.

4. Also check harness for short to ground and short to power.

OK or NG

OK >> GO TO 7.

NG >> Repair open circuit or short to ground or short to power in harness or connectors.

7. CHECK MAF SENSOR INPUT SIGNAL CIRCUIT FOR OPEN AND SHORT

1. Check harness continuity between MAF sensor terminal 4 and ECM terminal 51.
Refer to Wiring Diagram.

Continuity should exist.

2. Also check harness for short to ground and short to power.

OK or NG

OK >> GO TO 8.

NG >> Repair open circuit or short to ground or short to power in harness or connectors.

8. CHECK MASS AIR FLOW SENSOR

Refer to [EC-179, "Component Inspection"](#) .

OK or NG

OK >> GO TO 9.

NG >> Replace mass air flow sensor.

9. CHECK INTERMITTENT INCIDENT

Refer to [EC-135, "TROUBLE DIAGNOSIS FOR INTERMITTENT INCIDENT"](#) .

>> INSPECTION END

Component Inspection MASS AIR FLOW SENSOR

1. Reconnect all harness connectors disconnected.
2. Start engine and warm it up to normal operating temperature.
3. Check voltage between ECM terminal 51 (Mass air flow sensor signal) and ground.

Condition	Voltage V
Ignition switch ON (Engine stopped.)	Approx. 0.4
Idle (Engine is warmed-up to normal operating temperature.)	0.9 - 1.2
2,500 rpm (Engine is warmed-up to normal operating temperature.)	1.6 - 1.9
Idle to about 4,000 rpm*	0.9 - 1.2 to Approx. 2.4

*: Check for linear voltage rise in response to engine being increased to about 4,000 rpm.

4. If the voltage is out of specification, proceed the following.
 - Turn ignition switch OFF.
 - Disconnect mass air flow sensor harness connector and reconnect it again.
 - Perform steps 2 and 3 again.
5. If NG, remove mass air flow sensor from air duct. Check hot wire for damage or dust.
6. If NG, clean or replace mass air flow sensor.

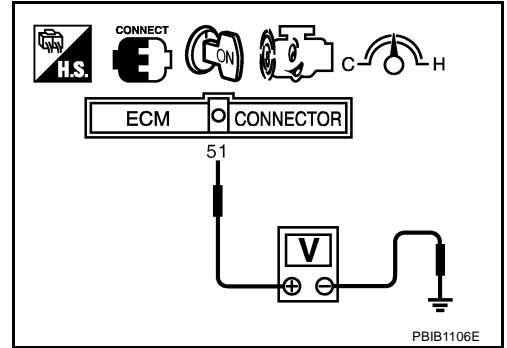

Removal and Installation MASS AIR FLOW SENSOR

Refer to [EM-17, "AIR CLEANER AND AIR DUCT"](#) .

DTC P0112, P0113 IAT SENSOR

PFP:22630

Component Description

ABS006MG

The intake air temperature sensor is built-into mass air flow sensor. The sensor detects intake air temperature and transmits a signal to the ECM.

The temperature sensing unit uses a thermistor which is sensitive to the change in temperature. Electrical resistance of the thermistor decreases in response to the temperature rise.

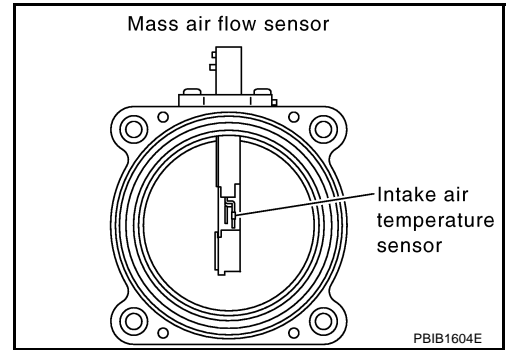

<Reference data>

Intake air temperature °C (°F)	Voltage* V	Resistance kΩ
25 (77)	3.32	1.94 - 2.06
80 (176)	1.23	0.295 - 0.349

*: This data is reference value and is measured between ECM terminal 34 (Intake air temperature sensor) and ground.

CAUTION:

Do not use ECM ground terminals when measuring input/output voltage. Doing so may result in damage to the ECM's transistor. Use a ground other than ECM terminals, such as the ground.

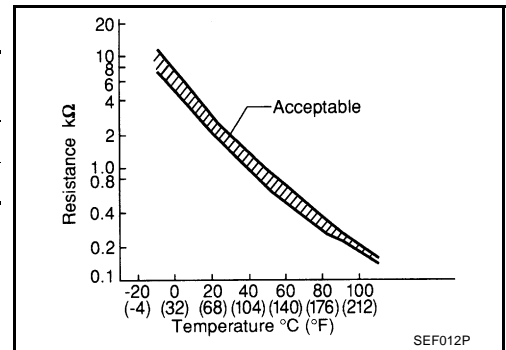

On Board Diagnosis Logic

ABS006MH

DTC No.	Trouble diagnosis name	DTC detecting condition	Possible cause
P0112 0112	Intake air temperature sensor circuit low input	An excessively low voltage from the sensor is sent to ECM.	<ul style="list-style-type: none"> ● Harness or connectors (The sensor circuit is open or shorted.) ● Intake air temperature sensor
P0113 0113	Intake air temperature sensor circuit high input	An excessively high voltage from the sensor is sent to ECM.	

DTC Confirmation Procedure

ABS006MI

NOTE:

If DTC Confirmation Procedure has been previously conducted, always turn ignition switch OFF and wait at least 10 seconds before conducting the next test.

Ⓟ WITH CONSULT-II

1. Turn ignition switch ON.
2. Select "DATA MONITOR" mode with CONSULT-II.
3. Wait at least 5 seconds.
4. If 1st trip DTC is detected, go to [EC-183, "Diagnostic Procedure"](#)

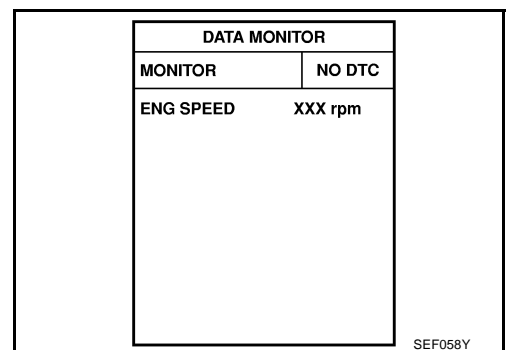

 **WITH GST**

Follow the procedure "WITH CONSULT-II" above.

A

EC

C

D

E

F

G

H

I

J

K

L

M

DTC P0112, P0113 IAT SENSOR

[VQ35DE]

ABS006MJ

Wiring Diagram

EC-IATS-01

: DETECTABLE LINE FOR DTC
 : NON-DETECTABLE LINE FOR DTC

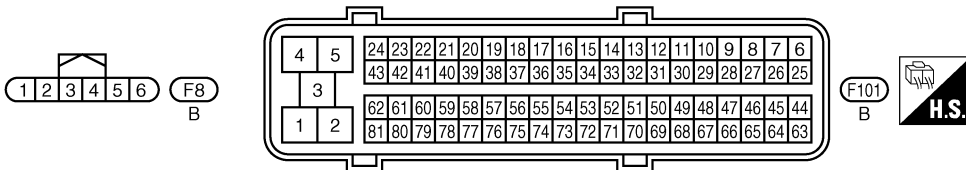
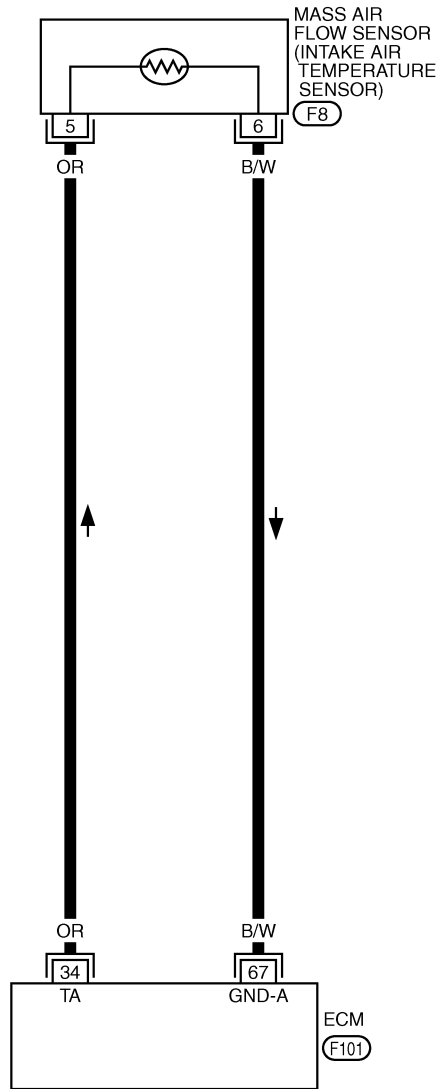

TBWM0288E

Diagnostic Procedure

1. CHECK GROUND CONNECTIONS

1. Turn ignition switch OFF.
2. Loosen and retighten ground three screws on the body. Refer to [EC-141, "Ground Inspection"](#).

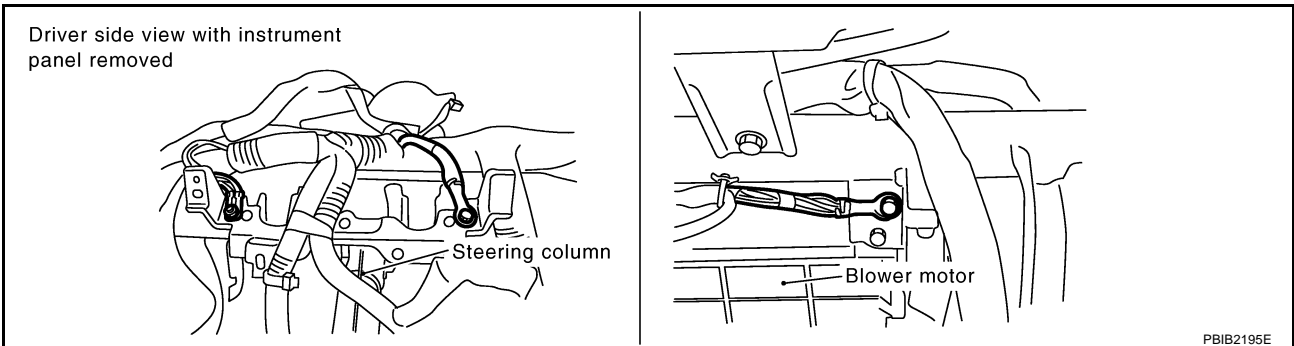

OK or NG

- OK >> GO TO 2.
- NG >> Repair or replace ground connections.

2. CHECK INTAKE AIR TEMPERATURE SENSOR POWER SUPPLY CIRCUIT

1. Disconnect mass air flow sensor (intake air temperature sensor is built-into) harness connector.
2. Turn ignition switch ON.

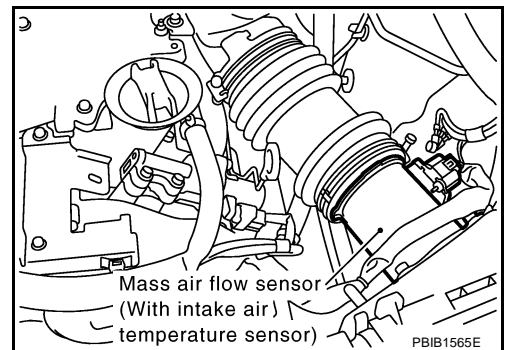

3. Check voltage between mass air flow sensor terminal 5 and ground.

Voltage: Approximately 5V

OK or NG

- OK >> GO TO 3.
- NG >> Repair harness or connectors.

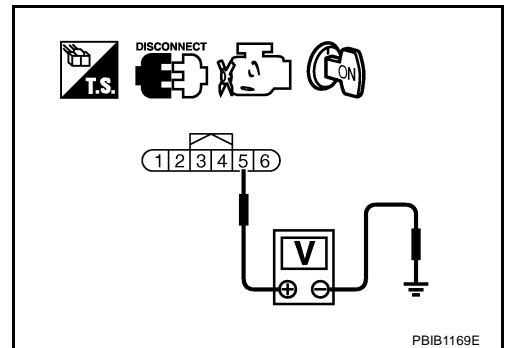

3. CHECK INTAKE AIR TEMPERATURE SENSOR GROUND CIRCUIT FOR OPEN AND SHORT

1. Turn ignition switch OFF.
2. Disconnect ECM harness connector.
3. Check harness continuity between mass air flow sensor terminal 6 and ECM terminal 67. Refer to Wiring Diagram.

Continuity should exist.

4. Also check harness for short to ground and short to power.

OK or NG

- OK >> GO TO 4.
- NG >> Repair open circuit or short to ground or short to power in harness or connectors.

A
EC
C
D
E
F
G
H
I
J
K
L
M

4. CHECK INTAKE AIR TEMPERATURE SENSOR

Refer to [EC-184, "Component Inspection"](#) .

OK or NG

OK >> GO TO 5.

NG >> Replace mass air flow sensor (with intake air temperature sensor).

5. CHECK INTERMITTENT INCIDENT

Refer to [EC-135, "TROUBLE DIAGNOSIS FOR INTERMITTENT INCIDENT"](#) .

>> INSPECTION END

Component Inspection INTAKE AIR TEMPERATURE SENSOR

ABS006ML

1. Check resistance between mass air flow sensor terminals 5 and 6 under the following conditions.

Intake air temperature °C (°F)	Resistance kΩ
25 (77)	1.94 - 2.06

2. If NG, replace mass air flow sensor (with intake air temperature sensor).

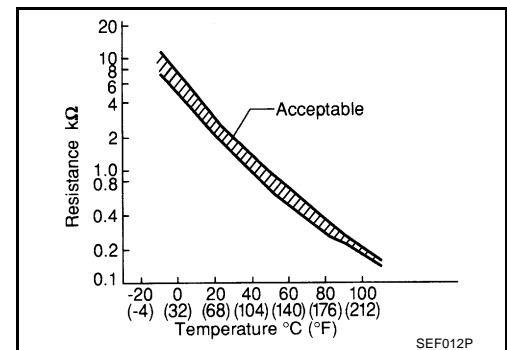
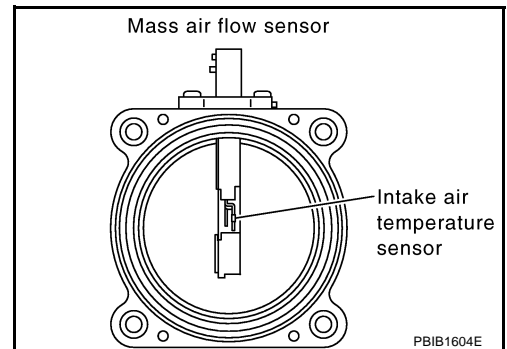

Removal and Installation MASS AIR FLOW SENSOR

ABS006MM

Refer to [EM-17, "AIR CLEANER AND AIR DUCT"](#) .

DTC P0117, P0118 ECT SENSOR

PFP:22630

Component Description

ABS006MN

The engine coolant temperature sensor is used to detect the engine coolant temperature. The sensor modifies a voltage signal from the ECM. The modified signal returns to the ECM as the engine coolant temperature input. The sensor uses a thermistor which is sensitive to the change in temperature. The electrical resistance of the thermistor decreases as temperature increases.

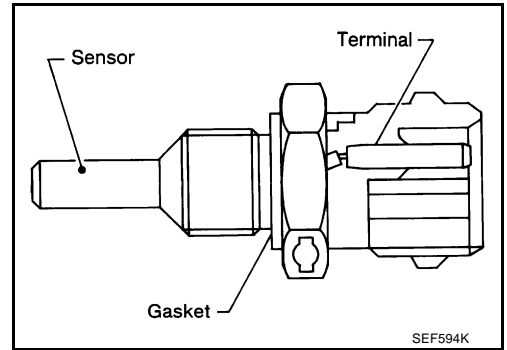

<Reference data>

Engine coolant temperature °C (°F)	Voltage* V	Resistance kΩ
20 (68)	3.5	2.1 - 2.9
50 (122)	2.2	0.68 - 1.00
90 (194)	0.9	0.236 - 0.260

*: This data is reference value and is measured between ECM terminal 73 (Engine coolant temperature sensor) and ground.

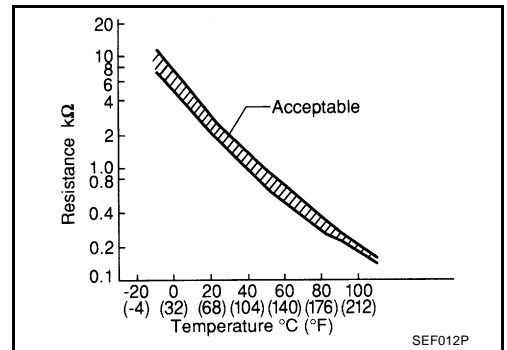

CAUTION:

Do not use ECM ground terminals when measuring input/output voltage. Doing so may result in damage to the ECM's transistor. Use a ground other than ECM terminals, such as the ground.

On Board Diagnosis Logic

ABS006MO

These self-diagnoses have the one trip detection logic.

DTC No.	Trouble Diagnosis Name	DTC Detecting Condition	Possible Cause
P0117 0117	Engine coolant temperature sensor circuit low input	An excessively low voltage from the sensor is sent to ECM.	<ul style="list-style-type: none"> ● Harness or connectors (The sensor circuit is open or shorted.) ● Engine coolant temperature sensor
P0118 0118	Engine coolant temperature sensor circuit high input	An excessively high voltage from the sensor is sent to ECM.	

FAIL-SAFE MODE

When the malfunction is detected, the ECM enters fail-safe mode and the MIL lights up.

Detected items	Engine operating condition in fail-safe mode	
Engine coolant temperature sensor circuit	Engine coolant temperature will be determined by ECM based on the time after turning ignition switch ON or START. CONSULT-II displays the engine coolant temperature decided by ECM.	
	Condition	Engine coolant temperature decided (CONSULT-II display)
	Just as ignition switch is turned ON or START	40°C (104°F)
	More than approx. 4 minutes after ignition ON or START	80°C (176°F)
	Except as shown above	40 - 80°C (104 - 176°F) (Depends on the time)
When the fail-safe system for engine coolant temperature sensor is activated, the cooling fan operates while engine is running.		

DTC Confirmation Procedure

NOTE:

If DTC Confirmation Procedure has been previously conducted, always turn ignition switch OFF and wait at least 10 seconds before conducting the next test.

④ WITH CONSULT-II

1. Turn ignition switch ON.
2. Select "DATA MONITOR" mode with CONSULT-II.
3. Wait at least 5 seconds.
4. If DTC is detected, go to [EC-188, "Diagnostic Procedure"](#) .

DATA MONITOR	
MONITOR	NO DTC
ENG SPEED	XXX rpm

SEF058Y

④ WITH GST

Follow the procedure "WITH CONSULT-II" above.

DTC P0117, P0118 ECT SENSOR

[VQ35DE]

Wiring Diagram

ABS006MQ

EC-ECTS-01

: DETECTABLE LINE FOR DTC
 : NON-DETECTABLE LINE FOR DTC

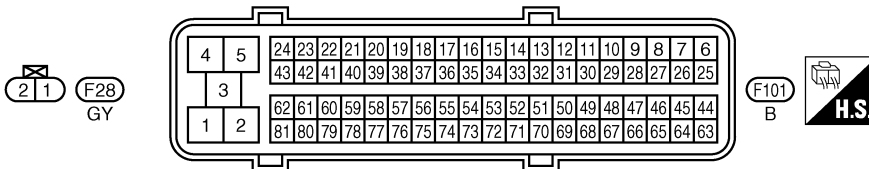
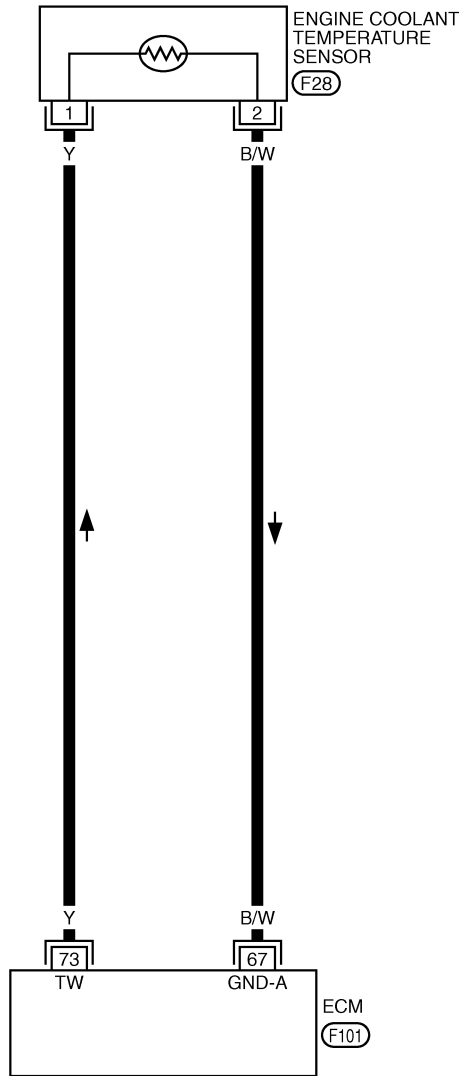

TBWM0289E

Diagnostic Procedure

1. CHECK GROUND CONNECTIONS

1. Turn ignition switch OFF.
2. Loosen and retighten ground three screws on the body. Refer to [EC-141, "Ground Inspection"](#).

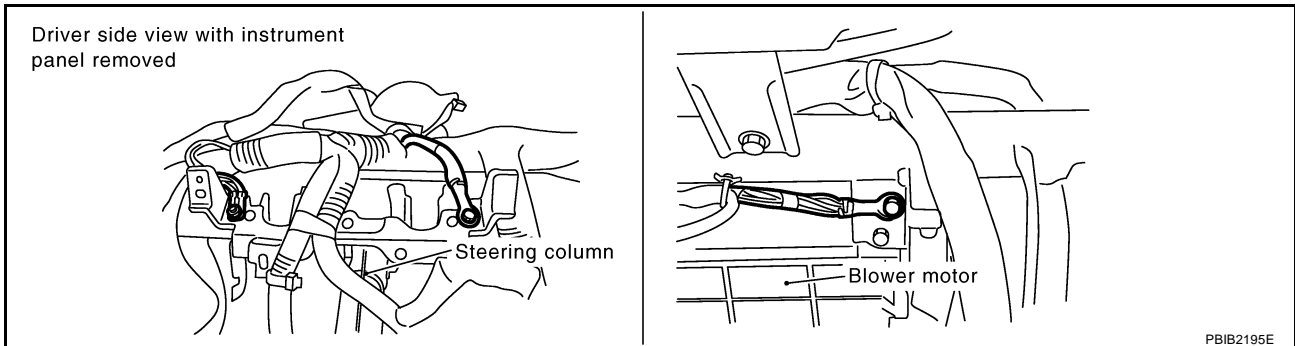

OK or NG

- OK >> GO TO 2.
 NG >> Repair or replace ground connections.

2. CHECK ECT SENSOR POWER SUPPLY CIRCUIT

1. Disconnect engine coolant temperature (ECT) sensor harness connector.
2. Turn ignition switch ON.

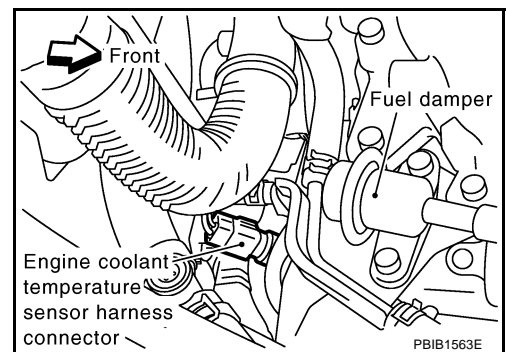

3. Check voltage between ECT sensor terminal 1 and ground with CONSULT-II or tester.

Voltage: Approximately 5V

OK or NG

- OK >> GO TO 3.
 NG >> Repair open circuit or short to ground or short to power in harness or connectors.

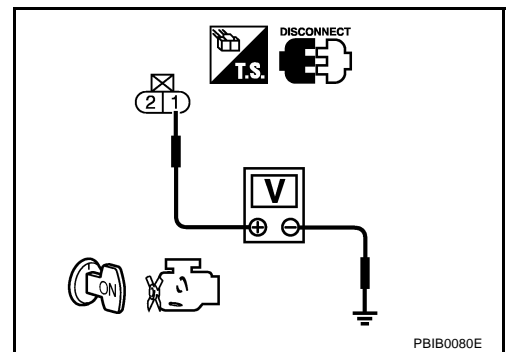

3. CHECK ECT SENSOR GROUND CIRCUIT FOR OPEN AND SHORT

1. Turn ignition switch OFF.
2. Disconnect ECM harness connector.
3. Check harness continuity between ECT sensor terminal 2 and ECM terminal 67.
Refer to Wiring Diagram.

Continuity should exist.

4. Also check harness for short to ground and short to power.

OK or NG

OK >> GO TO 4.

NG >> Repair open circuit or short to ground or short to power in harness or connectors.

4. CHECK ENGINE COOLANT TEMPERATURE SENSOR

Refer to [EC-189, "Component Inspection"](#) .

OK or NG

OK >> GO TO 5.

NG >> Replace engine coolant temperature sensor.

5. CHECK INTERMITTENT INCIDENT

Refer to [EC-135, "TROUBLE DIAGNOSIS FOR INTERMITTENT INCIDENT"](#) .

>> **INSPECTION END**

**Component Inspection
ENGINE COOLANT TEMPERATURE SENSOR**

ABS006MS

1. Check resistance between engine coolant temperature sensor terminals 1 and 2 as shown in the figure.

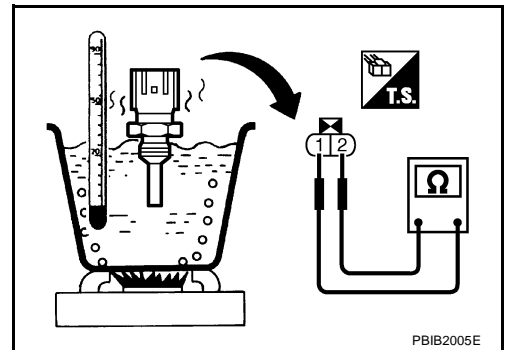

<Reference data>

Engine coolant temperature °C (°F)	Voltage* V	Resistance kΩ
20 (68)	3.5	2.1 - 2.9
50 (122)	2.2	0.68 - 1.00
90 (194)	0.9	0.236 - 0.260

*: This data is reference value and are measured between ECM terminal 73 (Engine coolant temperature sensor) and ground.

2. If NG, replace engine coolant temperature sensor.

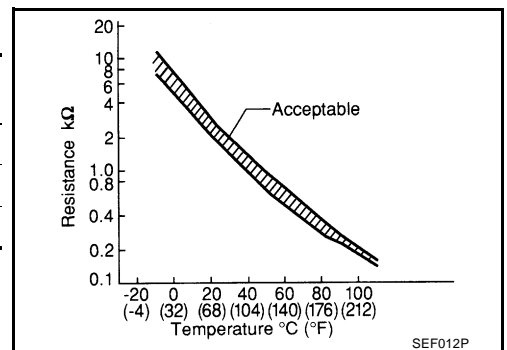

ABS006MT

**Removal and Installation
ENGINE COOLANT TEMPERATURE SENSOR**

Refer to [CO-26, "WATER INLET AND THERMOSTAT ASSEMBLY"](#) .

DTC P0122, P0123 TP SENSOR

PFP:16119

Component Description

ABS00CGT

Electric throttle control actuator consists of throttle control motor, throttle position sensor, etc. The throttle position sensor responds to the throttle valve movement.

The throttle position sensor has the two sensors. These sensors are a kind of potentiometers which transform the throttle valve position into output voltage, and emit the voltage signal to the ECM. In addition, these sensors detect the opening and closing speed of the throttle valve and feed the voltage signals to the ECM. The ECM judges the current opening angle of the throttle valve from these signals and the ECM controls the throttle control motor to make the throttle valve opening angle properly in response to driving condition.

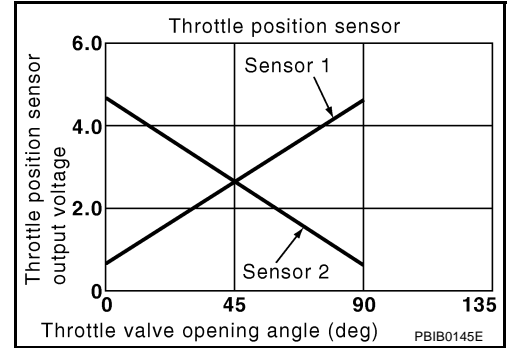

CONSULT-II Reference Value in Data Monitor Mode

ABS00CGU

Specification data are reference values.

MONITOR ITEM	CONDITION		SPECIFICATION
THRTL SEN1 THRTL SEN2*	<ul style="list-style-type: none"> Ignition switch: ON (Engine stopped) Shift lever: D 	Accelerator pedal: Fully released	More than 0.36V
		Accelerator pedal: Fully depressed	Less than 4.75V

*: Throttle position sensor 2 signal is converted by ECM internally. Thus, it differs from ECM terminal voltage signal.

On Board Diagnosis Logic

ABS00CGV

These self-diagnoses have the one trip detection logic.

DTC No.	Trouble diagnosis name	DTC detecting condition	Possible cause
P0122 0122	Throttle position sensor 2 circuit low input	An excessively low voltage from the TP sensor 2 is sent to ECM.	<ul style="list-style-type: none"> Harness or connectors (The TP sensor 2 circuit is open or shorted.) (APP sensor 2 circuit is shorted.) Electric throttle control actuator (TP sensor 2) Accelerator pedal position sensor
P0123 0123	Throttle position sensor 2 circuit high input	An excessively high voltage from the TP sensor 2 is sent to ECM.	

FAIL-SAFE MODE

When the malfunction is detected, ECM enters fail-safe mode and the MIL lights up.

Engine operation condition in fail-safe mode

The ECM controls the electric throttle control actuator in regulating the throttle opening in order for the idle position to be within +10 degrees.

The ECM regulates the opening speed of the throttle valve to be slower than the normal condition.

So, the acceleration will be poor.

DTC Confirmation Procedure

NOTE:

If DTC Confirmation Procedure has been previously conducted, always turn ignition switch OFF and wait at least 10 seconds before conducting the next test.

TESTING CONDITION:

Before performing the following procedure, confirm that battery voltage is more than 10V at idle.

WITH CONSULT-II

1. Turn ignition switch ON.
2. Select "DATA MONITOR" mode with CONSULT-II.
3. Start engine and let it idle for 1 second.
4. If DTC is detected, go to [EC-193, "Diagnostic Procedure"](#) .

DATA MONITOR	
MONITOR	NO DTC
ENG SPEED	XXX rpm
<small>SEF058Y</small>	

WITH GST

Follow the procedure "WITH CONSULT-II" above.

A
EC
C
D
E
F
G
H
I
J
K
L
M

DTC P0122, P0123 TP SENSOR

[VQ35DE]

ABS00CGX

Wiring Diagram

EC-TPS2-01

: DETECTABLE LINE FOR DTC
 : NON-DETECTABLE LINE FOR DTC

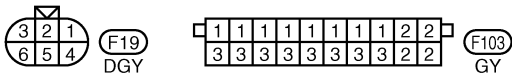
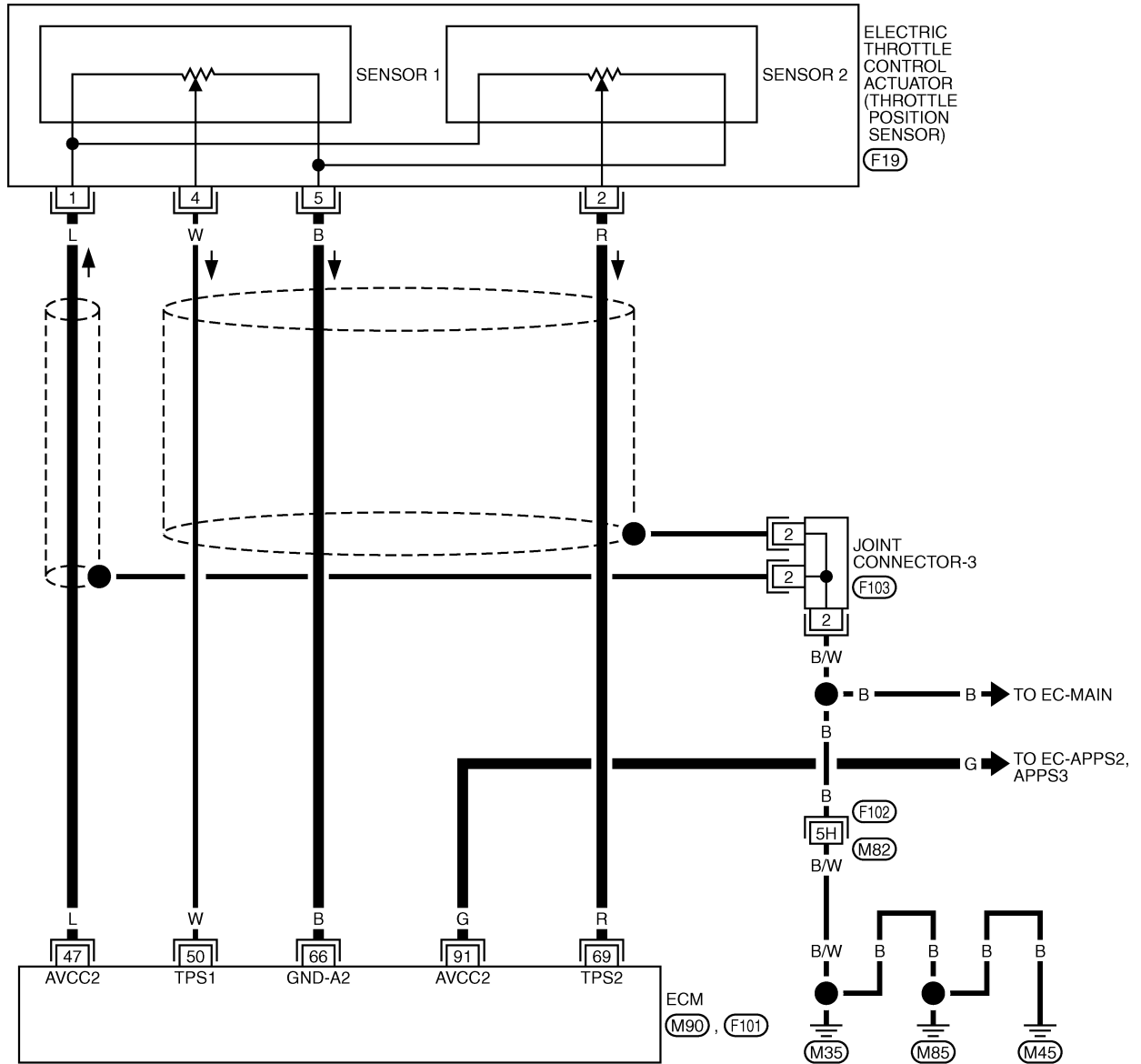

REFER TO THE FOLLOWING.
 (F102) -SUPER MULTIPLE JUNCTION (SMJ)

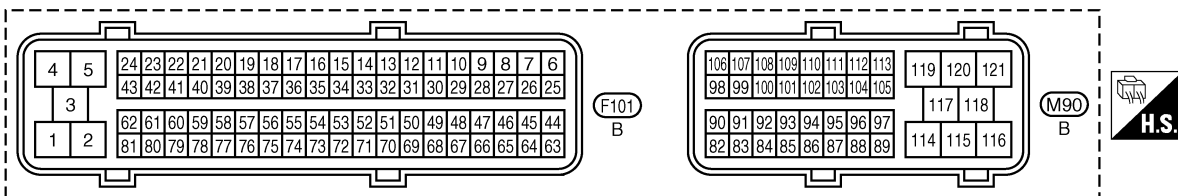

TBWM0429E

Specification data are reference values and are measured between each terminal and ground.

CAUTION:

Do not use ECM ground terminals when measuring input/output voltage. Doing so may result in damage to the ECM's transistor. Use a ground other than ECM terminals, such as the ground.

TER-MINAL NO.	WIRE COLOR	ITEM	CONDITION	DATA (DC Voltage)
47	L	Sensor power supply (Throttle position sensor)	[Ignition switch: ON]	Approximately 5V
50	W	Throttle position sensor 1	[Ignition switch: ON] ● Engine stopped ● Shift lever: D ● Accelerator pedal: Fully released	More than 0.36V
			[Ignition switch: ON] ● Engine stopped ● Shift lever: D ● Accelerator pedal: Fully depressed	Less than 4.75V
66	B	Sensor ground (Throttle position sensor)	[Engine is running] ● Warm-up condition ● Idle speed	Approximately 0V
69	R	Throttle position sensor 2	[Ignition switch: ON] ● Engine stopped ● Shift lever: D ● Accelerator pedal: Fully released	Less than 4.75V
			[Ignition switch: ON] ● Engine stopped ● Shift lever: D ● Accelerator pedal: Fully depressed	More than 0.36V
91	G	Sensor power supply (APP sensor 2)	[Ignition switch: ON]	Approximately 5V

Diagnostic Procedure

ABS00CGY

1. CHECK GROUND CONNECTIONS

1. Turn ignition switch OFF.
2. Loosen and retighten ground three screws on the body. Refer to [EC-141, "Ground Inspection"](#).

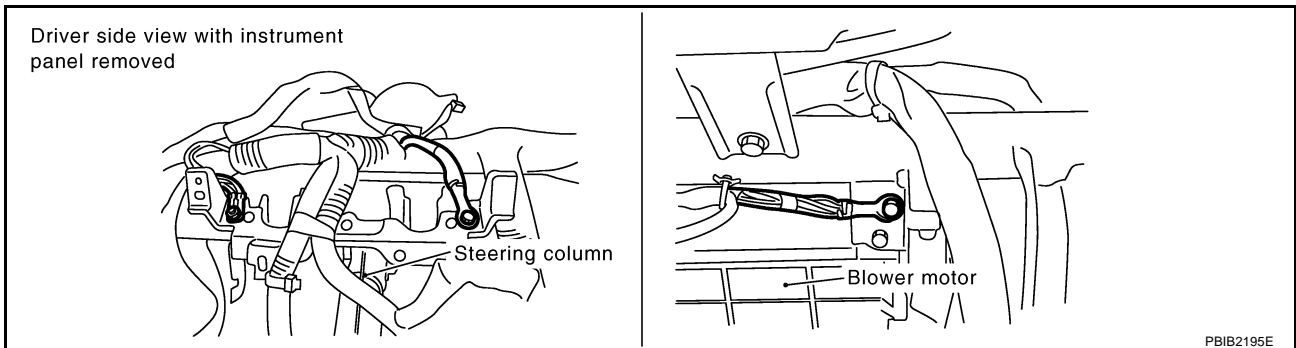

PBIB2195E

OK or NG

- OK >> GO TO 2.
- NG >> Repair or replace ground connections.

2. CHECK THROTTLE POSITION SENSOR 2 POWER SUPPLY CIRCUIT-I

1. Disconnect electric throttle control actuator harness connector.
2. Turn ignition switch ON.

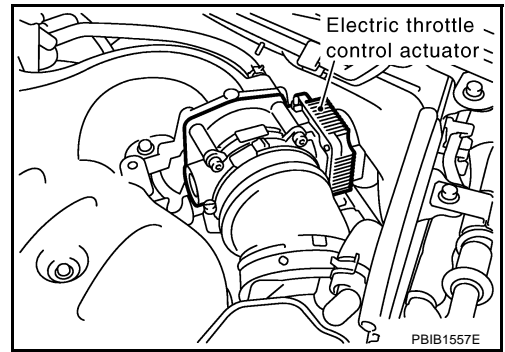

3. Check voltage between electric throttle control actuator terminal 1 and ground with CONSULT-II or tester.

Voltage: Approximately 5V

OK or NG

- OK >> GO TO 7.
 NG >> GO TO 3.

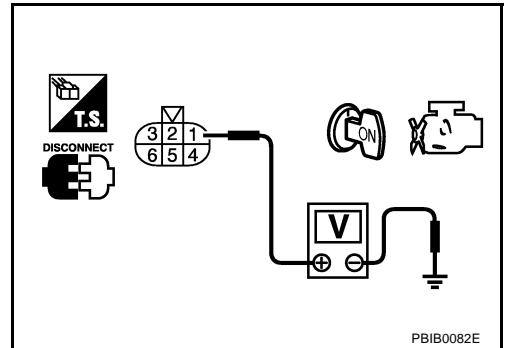

3. CHECK THROTTLE POSITION SENSOR 2 POWER SUPPLY CIRCUIT-II

1. Turn ignition switch OFF.
2. Disconnect ECM harness connector.
3. Check harness continuity between electric throttle control actuator terminal 1 and ECM terminal 47. Refer to Wiring Diagram.

Continuity should exist.

OK or NG

- OK >> GO TO 4.
 NG >> Repair or replace open circuit.

4. CHECK THROTTLE POSITION SENSOR 2 POWER SUPPLY CIRCUIT-III

Check the following.

- Harness for short to power and short to ground, between the following terminals.

ECM terminal	Sensor terminal	Reference Wiring Diagram
47	Electric throttle control actuator terminal 1	EC-192
91	APP sensor terminal 2	EC-564

OK or NG

- OK >> GO TO 5.
 NG >> Repair short to ground or short to power in harness or connectors.

5. CHECK APP SENSOR

Refer to [EC-568, "Component Inspection"](#).

OK or NG

- OK >> GO TO 11.
 NG >> GO TO 6.

6. REPLACE ACCELERATOR PEDAL ASSEMBLY

1. Replace accelerator pedal assembly.
2. Perform [EC-49, "Accelerator Pedal Released Position Learning"](#) .
3. Perform [EC-49, "Throttle Valve Closed Position Learning"](#) .
4. Perform [EC-49, "Idle Air Volume Learning"](#) .

>> INSPECTION END

7. CHECK THROTTLE POSITION SENSOR 2 GROUND CIRCUIT FOR OPEN AND SHORT

1. Turn ignition switch OFF.
2. Disconnect ECM harness connector.
3. Check harness continuity between electric throttle control actuator terminal 5 and ECM terminal 66.
Refer to Wiring Diagram.

Continuity should exist.

4. Also check harness for short to ground and short to power.

OK or NG

OK >> GO TO 8.

NG >> Repair open circuit or short to ground or short to power in harness or connectors.

8. CHECK THROTTLE POSITION SENSOR 2 INPUT SIGNAL CIRCUIT FOR OPEN AND SHORT

1. Check harness continuity between ECM terminal 69 and electric throttle control actuator terminal 2.
Refer to Wiring Diagram.

Continuity should exist.

2. Also check harness for short to ground and short to power.

OK or NG

OK >> GO TO 9.

NG >> Repair open circuit or short to ground or short to power in harness or connectors.

9. CHECK THROTTLE POSITION SENSOR

Refer to [EC-196, "Component Inspection"](#) .

OK or NG

OK >> GO TO 11.

NG >> GO TO 10.

10. REPLACE ELECTRIC THROTTLE CONTROL ACTUATOR

1. Replace the electric throttle control actuator.
2. Perform [EC-49, "Throttle Valve Closed Position Learning"](#) .
3. Perform [EC-49, "Idle Air Volume Learning"](#) .

>> INSPECTION END

11. CHECK INTERMITTENT INCIDENT

Refer to [EC-135, "TROUBLE DIAGNOSIS FOR INTERMITTENT INCIDENT"](#) .

>> INSPECTION END

Component Inspection
THROTTLE POSITION SENSOR

1. Reconnect all harness connectors disconnected.
2. Perform [EC-49, "Throttle Valve Closed Position Learning"](#) .
3. Turn ignition switch ON.
4. Set selector lever to D position.
5. Check voltage between ECM terminals 50 (TP sensor 1signal), 69 (TP sensor 2signal) and ground under the following conditions.

Terminal	Accelerator pedal	Voltage
50 (Throttle position sensor 1)	Fully released	More than 0.36V
	Fully depressed	Less than 4.75V
69 (Throttle position sensor 2)	Fully released	Less than 4.75V
	Fully depressed	More than 0.36V

6. If NG, replace electric throttle control actuator and go to the next step.
7. Perform [EC-49, "Throttle Valve Closed Position Learning"](#) .
8. Perform [EC-49, "Idle Air Volume Learning"](#) .

Removal and Installation
ELECTRIC THROTTLE CONTROL ACTUATOR

Refer to [EM-19, "INTAKE MANIFOLD COLLECTOR"](#) .

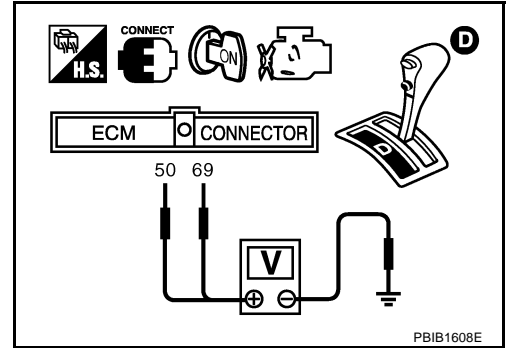

PBIB1608E

DTC P0125 ECT SENSOR

PFP:22630

Component Description

ABS006NA

NOTE:

If DTC P0125 is displayed with P0117 or P0118, first perform the trouble diagnosis for DTC P0117 or P0118. Refer to [EC-185](#).

The engine coolant temperature sensor is used to detect the engine coolant temperature. The sensor modifies a voltage signal from the ECM. The modified signal returns to the ECM as the engine coolant temperature input. The sensor uses a thermistor which is sensitive to the change in temperature. The electrical resistance of the thermistor decreases as temperature increases.

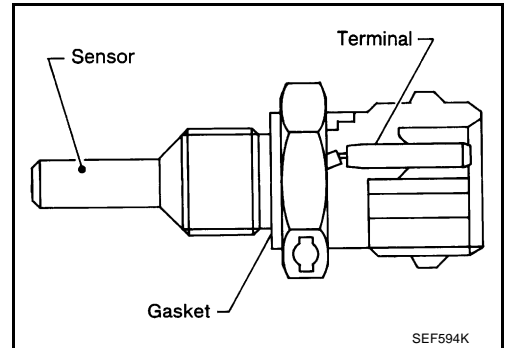

<Reference data>

Engine coolant temperature °C (°F)	Voltage* V	Resistance kΩ
-10 (14)	4.4	7.0 - 11.4
20 (68)	3.5	2.1 - 2.9
50 (122)	2.2	0.68 - 1.00
90 (194)	0.9	0.236 - 0.260

*: This data is reference value and is measured between ECM terminal 73 (Engine coolant temperature sensor) and ground.

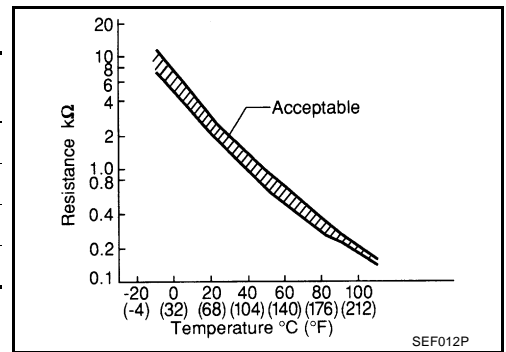

CAUTION:

Do not use ECM ground terminals when measuring input/output voltage. Doing so may result in damage to the ECM's transistor. Use a ground other than ECM terminals, such as the ground.

On Board Diagnosis Logic

ABS006NB

This self-diagnosis has the one trip detection logic.

DTC No.	Trouble diagnosis name	DTC detecting condition	Possible cause
P0125 0125	Insufficient engine coolant temperature for closed loop fuel control	<ul style="list-style-type: none"> ● Voltage sent to ECM from the sensor is not practical, even when some time has passed after starting the engine. ● Engine coolant temperature is insufficient for closed loop fuel control. 	<ul style="list-style-type: none"> ● Harness or connectors (High resistance in the circuit) ● Engine coolant temperature sensor ● Thermostat

DTC Confirmation Procedure

CAUTION:

Be careful not to overheat engine.

NOTE:

If DTC Confirmation Procedure has been previously conducted, always turn ignition switch OFF and wait at least 10 seconds before conducting the next test.

WITH CONSULT-II

1. Turn ignition switch ON.
2. Select "DATA MONITOR" mode with CONSULT-II.
3. Check that "COOLAN TEMP/S" is above 10°C (50°F).
If it is above 10°C (50°F), the test result will be OK.
If it is below 10°C (50°F), go to following step.
4. Start engine and run it for 65 minutes at idle speed.
If "COOLAN TEMP/S" increases to more than 10°C (50°F) within 65 minutes, stop engine because the test result will be OK.
5. If DTC is detected, go to [EC-198, "Diagnostic Procedure"](#) .

DATA MONITOR	
MONITOR	NO DTC
ENG SPEED	XXX rpm
COOLAN TEMP/S	XXX °C

SEF174Y

WITH GST

Follow the procedure "WITH CONSULT-II" above.

Diagnostic Procedure

1. CHECK GROUND CONNECTIONS

1. Turn ignition switch OFF.
2. Loosen and retighten ground three screws on the body. Refer to [EC-141, "Ground Inspection"](#) .

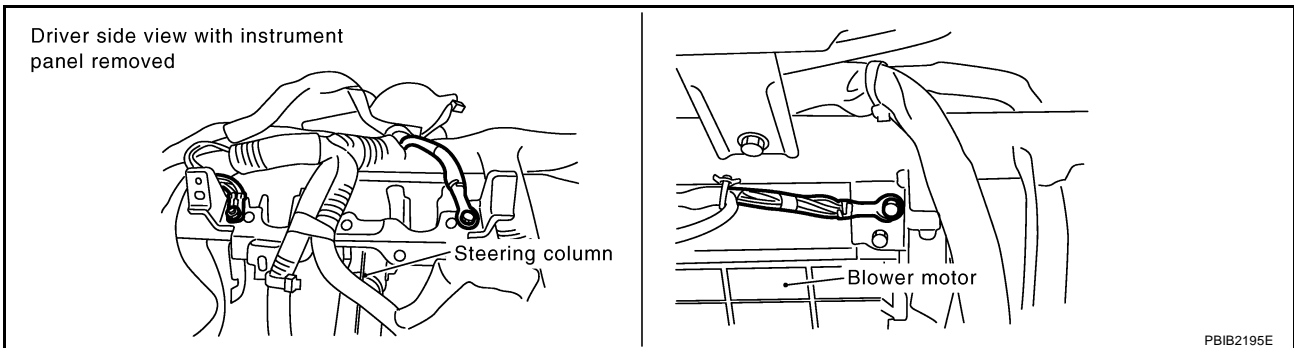

OK or NG

- OK >> GO TO 2.
- NG >> Repair or replace ground connections.

2. CHECK ENGINE COOLANT TEMPERATURE SENSOR

Refer to [EC-199, "Component Inspection"](#) .

OK or NG

- OK >> GO TO 3.
- NG >> Replace engine coolant temperature sensor.

3. CHECK THERMOSTAT OPERATION

When the engine is cold [lower than 70°C (158°F)] condition, grasp lower radiator hose and confirm the engine coolant does not flow.

OK or NG

OK >> GO TO 4.

NG >> Repair or replace thermostat. Refer to [CO-26, "WATER INLET AND THERMOSTAT ASSEMBLY"](#)

4. CHECK INTERMITTENT INCIDENT

Refer to [EC-135, "TROUBLE DIAGNOSIS FOR INTERMITTENT INCIDENT"](#) .

Refer to [EC-187, "Wiring Diagram"](#) .

>> INSPECTION END

Component Inspection ENGINE COOLANT TEMPERATURE SENSOR

ABS006NE

1. Check resistance between engine coolant temperature sensor terminals 1 and 2 as shown in the figure.

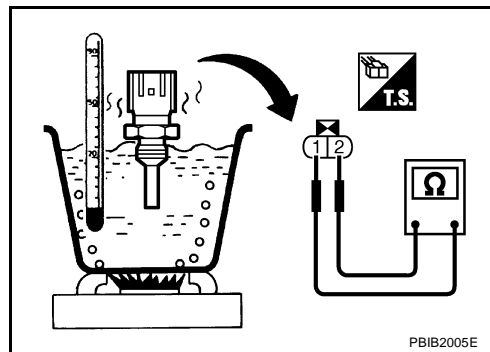

<Reference data>

Engine coolant temperature °C (°F)	Voltage* V	Resistance kΩ
20 (68)	3.5	2.1 - 2.9
50 (122)	2.2	0.68 - 1.00
90 (194)	0.9	0.236 - 0.260

*: This data is reference value and is measured between ECM terminal 73 (Engine coolant temperature sensor) and ground.

2. If NG, replace engine coolant temperature sensor.

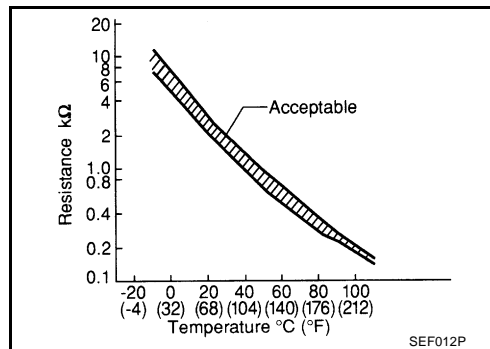

SEF012P

ABS006NF

Removal and Installation ENGINE COOLANT TEMPERATURE SENSOR

Refer to [CO-26, "WATER INLET AND THERMOSTAT ASSEMBLY"](#) .

DTC P0127 IAT SENSOR

PFP:22630

Component Description

ABS006NG

The intake air temperature sensor is built into mass air flow sensor. The sensor detects intake air temperature and transmits a signal to the ECM.

The temperature sensing unit uses a thermistor which is sensitive to the change in temperature. Electrical resistance of the thermistor decreases in response to the temperature rise.

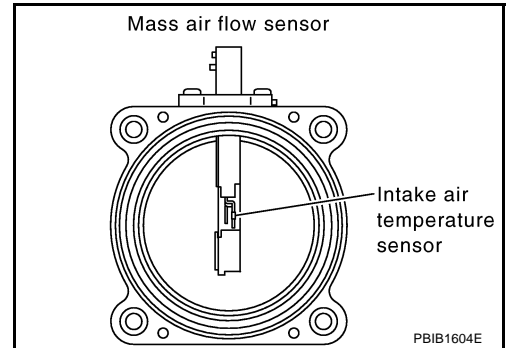

<Reference data>

Intake air temperature °C (°F)	Voltage* V	Resistance kΩ
25 (77)	3.32	1.94 - 2.06
80 (176)	1.23	0.295 - 0.349

*: This data is reference value and is measured between ECM terminal 34 (Intake air temperature sensor) and ground.

CAUTION:

Do not use ECM ground terminals when measuring input/output voltage. Doing so may result in damage to the ECM's transistor. Use a ground other than ECM terminals, such as the ground.

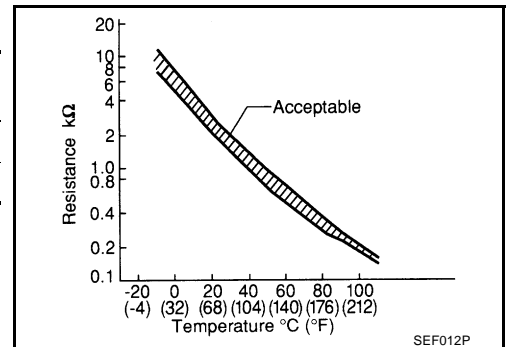

On Board Diagnosis Logic

ABS006NH

DTC No.	Trouble diagnosis name	DTC detecting condition	Possible cause
P0127 0127	Intake air temperature too high	Rationally incorrect voltage from the sensor is sent to ECM, compared with the voltage signal from engine coolant temperature sensor.	<ul style="list-style-type: none"> ● Harness or connectors (The sensor circuit is open or shorted) ● Intake air temperature sensor

DTC Confirmation Procedure

ABS006NI

NOTE:

If DTC Confirmation Procedure has been previously conducted, always turn ignition switch OFF and wait at least 10 seconds before conducting the next test.

CAUTION:

Always drive vehicle at a safe speed.

TESTING CONDITION:

This test may be conducted with the drive wheels lifted in the shop or by driving the vehicle. If a road test is expected to be easier, it is unnecessary to lift the vehicle.

④ WITH CONSULT-II

1. Wait until engine coolant temperature is less than 90°C (194°F)
 - a. Turn ignition switch ON.

- b. Select "DATA MONITOR" mode with CONSULT-II.
- c. Check the engine coolant temperature.
- d. If the engine coolant temperature is not less than 90°C (194°F), turn ignition switch OFF and cool down engine.
 - Perform the following steps before engine coolant temperature is above 90°C (194°F).
2. Turn ignition switch ON.
3. Select "DATA MONITOR" mode with CONSULT-II.
4. Start engine.
5. Hold vehicle speed at more than 70 km/h (43 MPH) for 100 consecutive seconds.
6. If 1st trip DTC is detected, go to [EC-201, "Diagnostic Procedure"](#).

DATA MONITOR	
MONITOR	NO DTC
ENG SPEED	XXX rpm
COOLAN TEMP/S	XXX °C
VHCL SPEED SE	XXX km/h
B/FUEL SCHDL	XXX msec

SEF189Y

WITH GST

Follow the procedure "WITH CONSULT-II" above.

Diagnostic Procedure

ABS006NJ

1. CHECK GROUND CONNECTIONS

1. Turn ignition switch OFF.
2. Loosen and retighten ground three screws on the body. Refer to [EC-141, "Ground Inspection"](#).

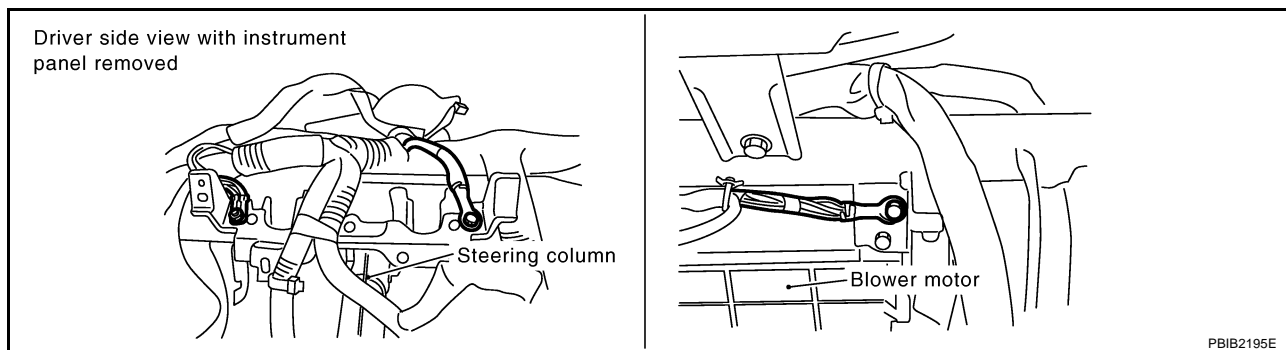

OK or NG

- OK >> GO TO 2.
- NG >> Repair or replace ground connections.

2. CHECK INTAKE AIR TEMPERATURE SENSOR

Refer to [EC-202, "Component Inspection"](#).

OK or NG

- OK >> GO TO 3.
- NG >> Replace mass air flow sensor (with intake air temperature sensor).

3. CHECK INTERMITTENT INCIDENT

Refer to [EC-135, "TROUBLE DIAGNOSIS FOR INTERMITTENT INCIDENT"](#).

Refer to [EC-182, "Wiring Diagram"](#).

>> INSPECTION END

Component Inspection INTAKE AIR TEMPERATURE SENSOR

1. Check resistance between intake air temperature sensor terminals 5 and 6 under the following conditions.

Intake air temperature °C (°F)	Resistance kΩ
25 (77)	1.94 - 2.06

2. If NG, replace mass air flow sensor (with intake air temperature sensor).

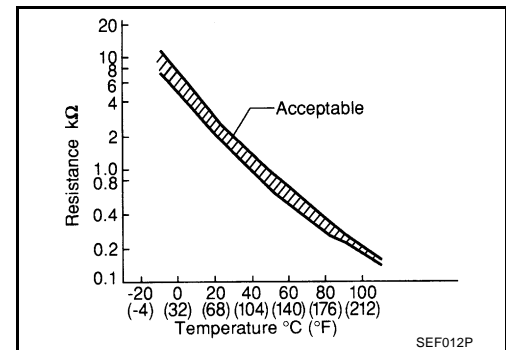
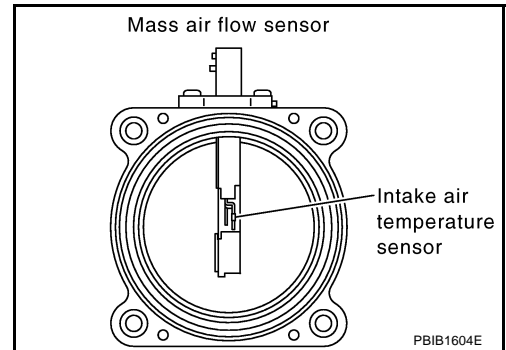

Removal and Installation MASS AIR FLOW SENSOR

Refer to [EM-17, "AIR CLEANER AND AIR DUCT"](#) .

DTC P0128 THERMOSTAT FUNCTION

PFP:21200

On Board Diagnosis Logic

ABS006NM

Engine coolant temperature has not risen enough to open the thermostat even though the engine has run long enough.

This is due to a leak in the seal or the thermostat stuck open.

DTC No.	Trouble diagnosis name	DTC detecting condition	Possible cause
P0128 0128	Thermostat function	The engine coolant temperature does not reach to specified temperature even though the engine has run long enough.	<ul style="list-style-type: none"> ● Thermostat ● Leakage from sealing portion of thermostat ● Engine coolant temperature sensor

DTC Confirmation Procedure

ABS006NN

NOTE:

If DTC Confirmation Procedure has been previously conducted, always turn ignition switch OFF and wait at least 10 seconds before conducting the next test.

TESTING CONDITION:

- For best results, perform at ambient temperature of -10°C (14°F) or higher.
- For best results, perform at engine coolant temperature of -10°C (14°F) to 60°C (140°F).

WITH CONSULT-II

1. Replace thermostat with new one. Refer to [CO-26, "WATER INLET AND THERMOSTAT ASSEMBLY"](#). Use only a genuine NISSAN thermostat as a replacement. If an incorrect thermostat is used, the MIL may come on.
2. Turn ignition switch ON.
3. Select "COOLAN TEMP/S" in "DATA MONITOR" mode with CONSULT-II.
4. Check that the "COOLAN TEMP/S" is above 60°C (140°F).
If it is below 60°C (140°F), go to following step.
If it is above 60°C (140°F), cool down the engine to less than 60°C (140°F), then retry from step 1.
5. Drive vehicle for 10 consecutive minutes under the following conditions.

VHCL SPEED SE	80 - 120 km/h (50 - 75 MPH)
---------------	-----------------------------

If 1st trip DTC is detected, go to [EC-203, "Diagnostic Procedure"](#).

DATA MONITOR	
MONITOR	NO DTC
COOLAN TEMP/S	XXX °C
VHCL SPEED SE	XXX km/h

SEP176Y

WITH GST

1. Follow the procedure "WITH CONSULT-II" above.

Diagnostic Procedure

ABS006NO

1. CHECK ENGINE COOLANT TEMPERATURE SENSOR

Refer to [EC-204, "Component Inspection"](#).

OK or NG

- OK >> **INSPECTION END**
- NG >> Replace engine coolant temperature sensor.

Component Inspection ENGINE COOLANT TEMPERATURE SENSOR

1. Check resistance between engine coolant temperature sensor terminals 1 and 2 as shown in the figure.

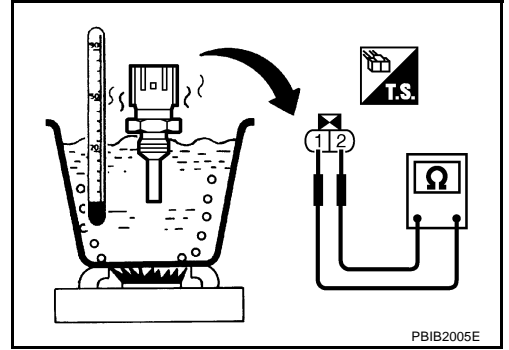

PBIB2005E

<Reference data>

Engine coolant temperature °C (°F)	Voltage* V	Resistance kΩ
20 (68)	3.5	2.1 - 2.9
50 (122)	2.2	0.68 - 1.00
90 (194)	0.9	0.236 - 0.260

*: This data is reference value and is measured between ECM terminal 73 (Engine coolant temperature sensor) and ground.

2. If NG, replace engine coolant temperature sensor.

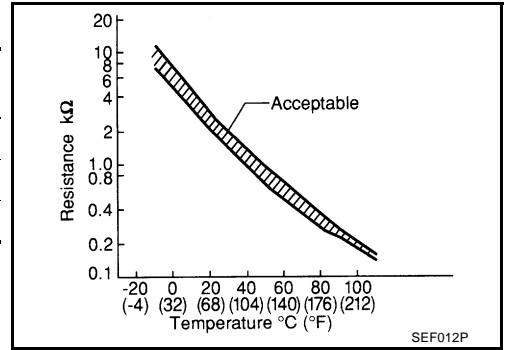

SEF012P

Removal and Installation ENGINE COOLANT TEMPERATURE SENSOR

Refer to [CO-26, "WATER INLET AND THERMOSTAT ASSEMBLY"](#).

DTC P0132, P0152 HO2S1

PFP:22690

Component Description

ABS006NR

The heated oxygen sensor 1 is placed into the exhaust manifold. It detects the amount of oxygen in the exhaust gas compared to the outside air. The heated oxygen sensor 1 has a closed-end tube made of ceramic zirconia. The zirconia generates voltage from approximately 1V in richer conditions to 0V in leaner conditions. The heated oxygen sensor 1 signal is sent to the ECM. The ECM adjusts the injection pulse duration to achieve the ideal air-fuel ratio. The ideal air-fuel ratio occurs near the radical change from 1 to 0V.

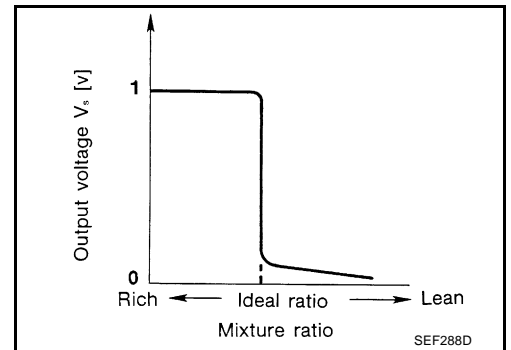
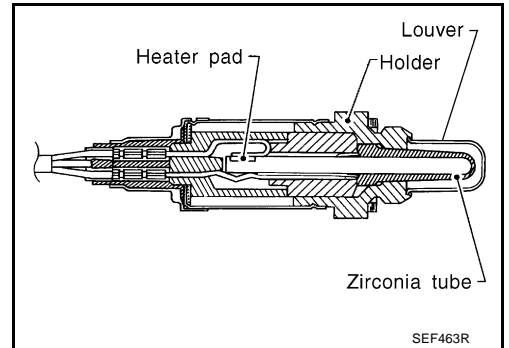

CONSULT-II Reference Value in Data Monitor Mode

ABS006NS

Specification data are reference values.

MONITOR ITEM	CONDITION		SPECIFICATION
HO2S1 (B1) HO2S1 (B2)			0 - 0.3V ↔ Approx. 0.6 - 1.0V
HO2S1 MNTR (B1) HO2S1 MNTR (B2)	● Engine: After warming up	Maintaining engine speed at 2,000 rpm	LEAN ↔ RICH Changes more than 5 times during 10 seconds.

On Board Diagnosis Logic

ABS006NT

To judge the malfunction, the diagnosis checks that the heated oxygen sensor 1 output is not inordinately high.

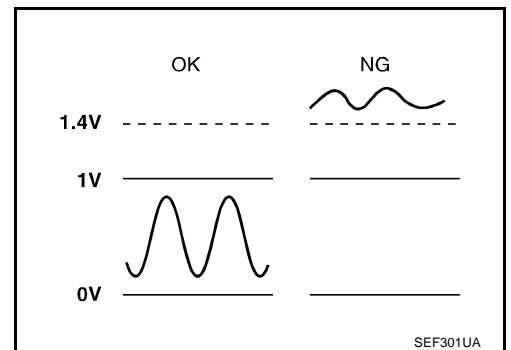

DTC No.	Trouble diagnosis name	DTC detecting condition	Possible cause
P0132 0132 (Bank 1)	Heated oxygen sensor 1 circuit high voltage	An excessively high voltage from the sensor is sent to ECM.	<ul style="list-style-type: none"> ● Harness or connectors (The sensor circuit is open or shorted) ● Heated oxygen sensor 1
P0152 0152 (Bank 2)			

DTC Confirmation Procedure

NOTE:

If DTC Confirmation Procedure has been previously conducted, always turn ignition switch OFF and wait at least 10 seconds before conducting the next test.

WITH CONSULT-II

1. Start engine and warm it up to normal operating temperature.
2. Turn ignition switch OFF and wait at least 10 seconds.
3. Turn ignition switch ON.
4. Select "DATA MONITOR" mode with CONSULT-II.
5. Restart engine and let it idle for 2 minutes.
6. If 1st trip DTC is detected, go to [EC-210, "Diagnostic Procedure"](#).

DATA MONITOR	
MONITOR	NO DTC
ENG SPEED	XXX rpm
COOLANTEMP/S	XXX °C

SEF174Y

WITH GST

Follow the procedure "WITH CONSULT-II" above.

Wiring Diagram
BANK 1

EC-O2S1B1-01

— : DETECTABLE LINE FOR DTC
 — : NON-DETECTABLE LINE FOR DTC

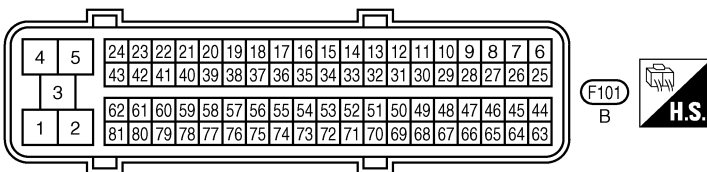
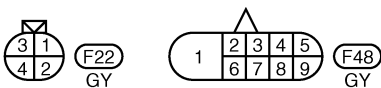
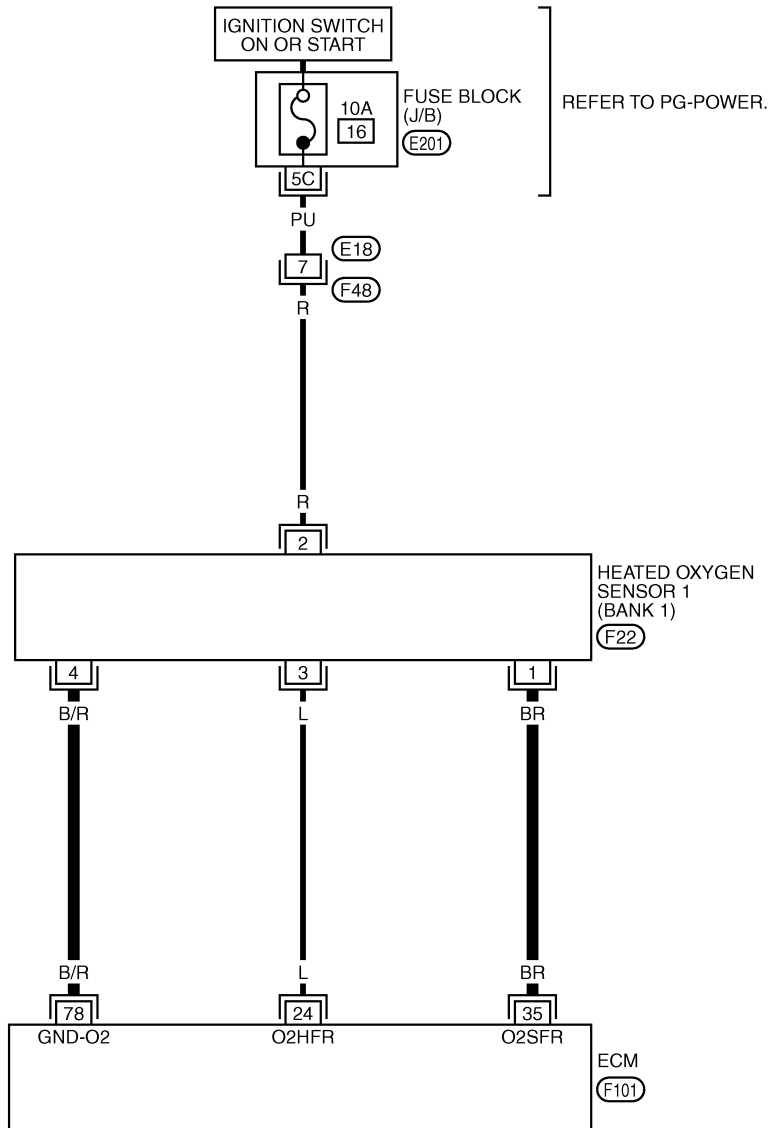

REFER TO THE FOLLOWING.
 (E201) - FUSE BLOCK-JUNCTION BOX (J/B)

DTC P0132, P0152 HO2S1

[VQ35DE]

Specification data are reference values and are measured between each terminal and ground.

CAUTION:

Do not use ECM ground terminals when measuring input/output voltage. Doing so may result in damage to the ECM's transistor. Use a ground other than ECM terminals, such as the ground.

TER-MINAL NO.	WIRE COLOR	ITEM	CONDITION	DATA (DC Voltage)
35	BR	Heated oxygen sensor 1 (bank 1)	[Engine is running] <ul style="list-style-type: none">● Warm-up condition● Engine speed is 2,000 rpm	0 - Approximately 1.0V (Periodically change)
78	B/R	Sensor ground (Heated oxygen sensor)	[Engine is running] <ul style="list-style-type: none">● Warm-up condition● Idle speed	Approximately 0V

BANK 2

EC-O2S1B2-01

— : DETECTABLE LINE FOR DTC
 — : NON-DETECTABLE LINE FOR DTC

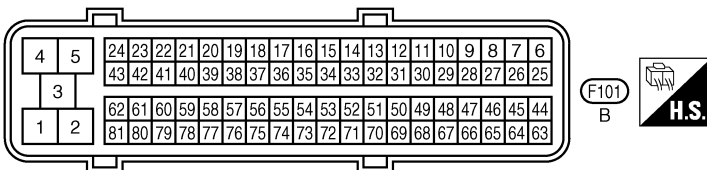
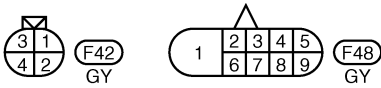
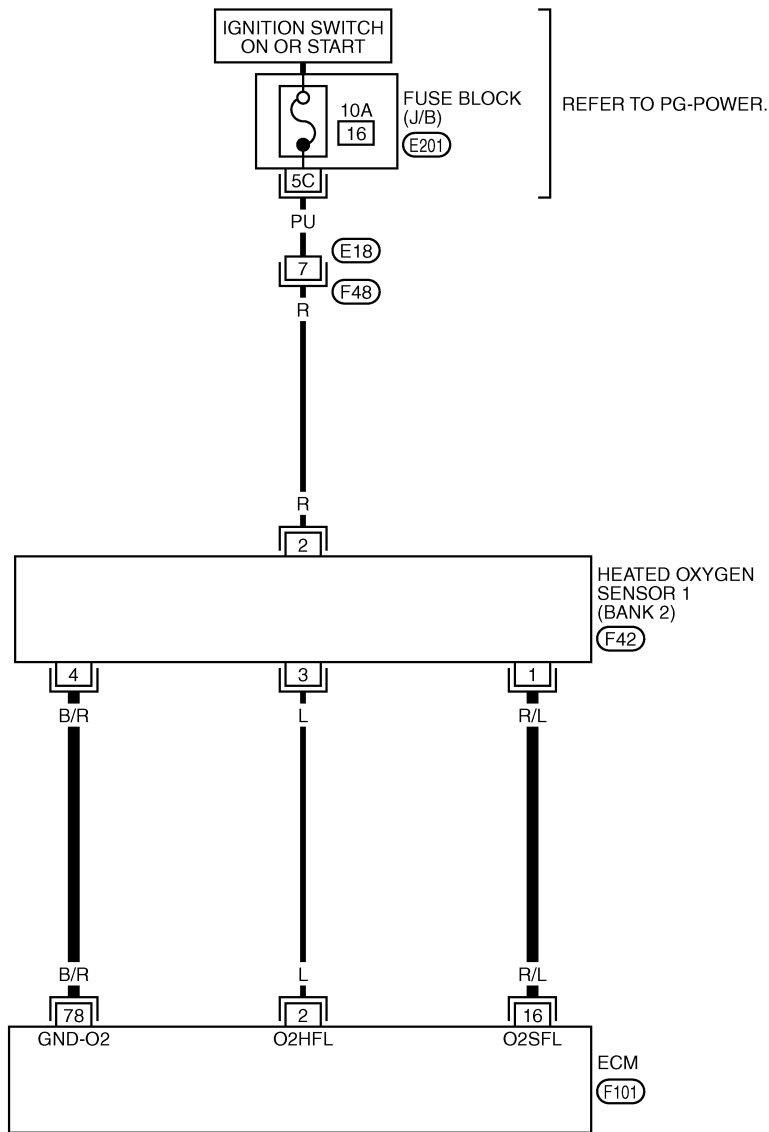

REFER TO THE FOLLOWING.
 (E201) - FUSE BLOCK-JUNCTION BOX (J/B)

Specification data are reference values and are measured between each terminal and ground.

CAUTION:

Do not use ECM ground terminals when measuring input/output voltage. Doing so may result in damage to the ECM's transistor. Use a ground other than ECM terminals, such as the ground.

TER-MINAL NO.	WIRE COLOR	ITEM	CONDITION	DATA (DC Voltage)
16	R/L	Heated oxygen sensor 1 (bank 2)	[Engine is running] <ul style="list-style-type: none"> ● Warm-up condition ● Engine speed is 2,000 rpm 	0 - Approximately 1.0V (Periodically change)
78	B/R	Sensor ground (Heated oxygen sensor)	[Engine is running] <ul style="list-style-type: none"> ● Warm-up condition ● Idle speed 	Approximately 0V

Diagnostic Procedure

ABS006NW

1. CHECK GROUND CONNECTIONS

1. Turn ignition switch OFF.
2. Loosen and retighten ground three screws on the body. Refer to [EC-141, "Ground Inspection"](#).

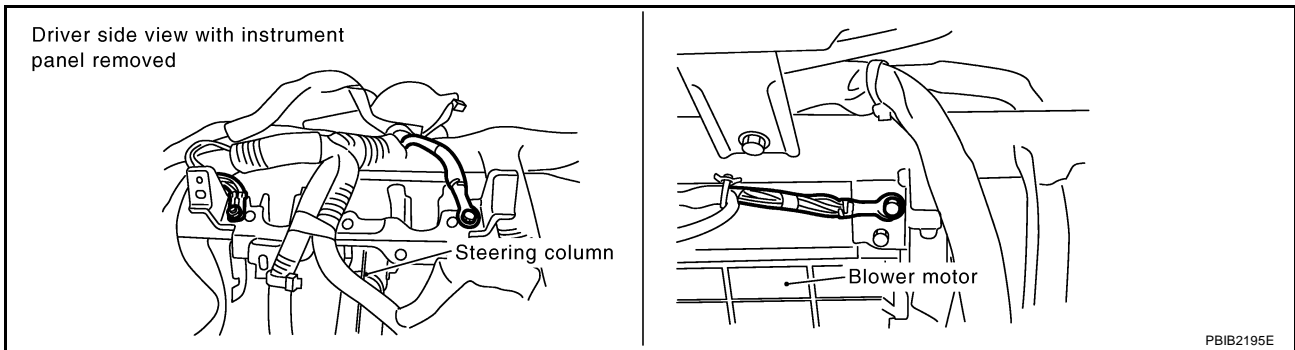

OK or NG

- OK >> GO TO 2.
- NG >> Repair or replace ground connections.

2. RETIGHTEN HEATED OXYGEN SENSOR 1

Loosen and retighten corresponding heated oxygen sensor 1.

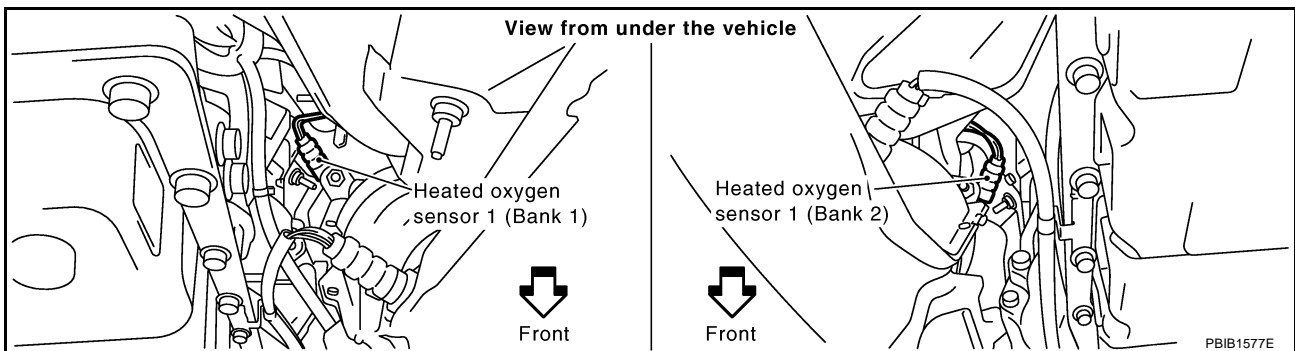

Tightening torque: 45 N·m (4.6 kg-m, 33 ft-lb)

>> GO TO 3.

3. CHECK HO2S1 GROUND CIRCUIT FOR OPEN AND SHORT

1. Disconnect heated oxygen sensor 1 harness connector.

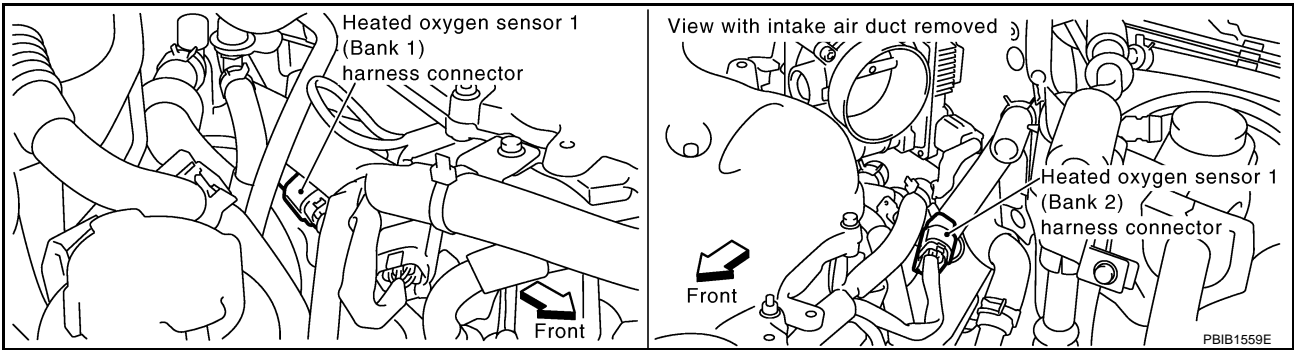

2. Disconnect ECM harness connector.
3. Check harness continuity between HO2S1 terminal 4 and ECM terminal 78.
Refer to Wiring Diagram.

Continuity should exist.

4. Also check harness for short to ground and short to power.

OK or NG

OK >> GO TO 4.

NG >> Repair open circuit or short to ground short to power in harness or connectors.

4. CHECK HO2S1 INPUT SIGNAL CIRCUIT FOR OPEN AND SHORT

1. Check harness continuity between ECM terminal and HO2S1 terminal as follows.
Refer to Wiring Diagram.

DTC	Terminals		Bank
	ECM	Sensor	
P0132	35	1	1
P0152	16	1	2

Continuity should exist.

2. Check harness continuity between the following terminals and ground.
Refer to Wiring Diagram.

DTC	Terminals		Bank
	ECM	Sensor	
P0132	35	1	1
P0152	16	1	2

Continuity should not exist.

3. Also check harness for short to power.

OK or NG

OK >> GO TO 5.

NG >> Repair open circuit or short to ground or short to power in harness or connectors.

5. CHECK HO2S1 CONNECTOR FOR WATER

1. Turn ignition switch OFF.
2. Disconnect heated oxygen sensor 1 harness connector.
3. Check connectors for water.

Water should not exist.

OK or NG

- OK >> GO TO 6.
NG >> Repair or replace harness or connectors.

6. CHECK HEATED OXYGEN SENSOR 1

Refer to [EC-212, "Component Inspection"](#) .

OK or NG

- OK >> GO TO 7.
NG >> Replace malfunctioning heated oxygen sensor 1.

7. CHECK INTERMITTENT INCIDENT

Refer to [EC-135, "TROUBLE DIAGNOSIS FOR INTERMITTENT INCIDENT"](#) .

>> INSPECTION END

Component Inspection HEATED OXYGEN SENSOR 1

ABS006NX

With CONSULT-II

1. Start engine and warm it up to normal operating temperature.
2. Select "MANU TRIG" and adjust "TRIGGER POINT" to 100% in "DATA MONITOR" mode with CONSULT-II.
3. Select "HO2S1 (B1)/(B2)" and "HO2S1 MNTR (B1)/(B2)".
4. Hold engine speed at 2,000 rpm under no load during the following steps.
5. Touch "RECORD" on CONSULT-II screen.

DATA MONITOR	
MONITOR	NO DTC
ENG SPEED	XXX rpm
MAS A/F SE-B1	XXX V
COOLAN TEMP/S	XXX °C
HO2S1 (B1)	XXX V
HO2S1 MNTR (B1)	LEAN

SEF646Y

6. Check the following.
 - "HO2S1 MNTR (B1)/(B2)" in "DATA MONITOR" mode changes from "RICH" to "LEAN" to "RICH" 5 times in 10 seconds.
5 times (cycles) are counted as shown at right.
 - "HO2S1 (B1)/(B2)" voltage goes above 0.6V at least once.
 - "HO2S1 (B1)/(B2)" voltage goes below 0.3V at least once.
 - "HO2S1 (B1)/(B2)" voltage never exceeds 1.0V.

Bank 1	cycle	1	2	3	4	5
	HO2S1 MNTR (B1)	R-L-R-L-R-L-R-L-R-L-R				
Bank 2	cycle	1	2	3	4	5
	HO2S1 MNTR (B2)	R-L-R-L-R-L-R-L-R-L-R				
R means HO2S1 MNTR (B1)/(B2) indicates RICH L means HO2S1 MNTR (B1)/(B2) indicates LEAN						

SEF647Y

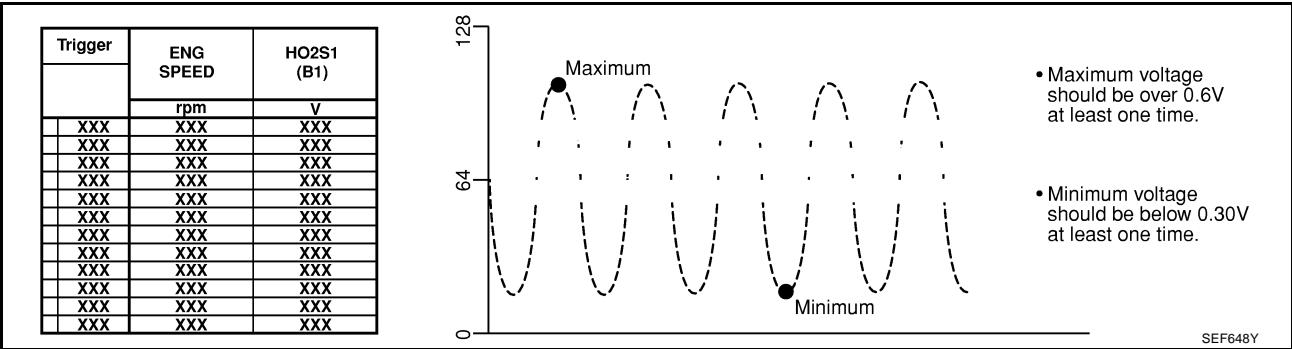

CAUTION:

- Discard any heated oxygen sensor which has been dropped from a height of more than 0.5 m (19.7 in) onto a hard surface such as a concrete floor; use a new one.
- Before installing new oxygen sensor, clean exhaust system threads using Oxygen Sensor Thread Cleaner tool J-43897-18 or J-43897-12 and approved anti-seize lubricant.

Without CONSULT-II

1. Start engine and warm it up to normal operating temperature.
2. Set voltmeter probes between ECM terminal 35 [HO2S1 (B1) signal] or 16 [HO2S1 (B2) signal] and ground.
3. Check the following with engine speed held at 2,000 rpm constant under no load.
 - The voltage fluctuates between 0 to 0.3V and 0.6 to 1.0V more than 5 times within 10 seconds.
 - The maximum voltage is over 0.6V at least one time.
 - The minimum voltage is below 0.3V at least one time.
 - The voltage never exceeds 1.0V.

1 time: 0 - 0.3V → 0.6 - 1.0V → 0 - 0.3V
 2 times: 0 - 0.3V → 0.6 - 1.0V → 0 - 0.3V → 0.6 - 1.0V → 0 - 0.3V

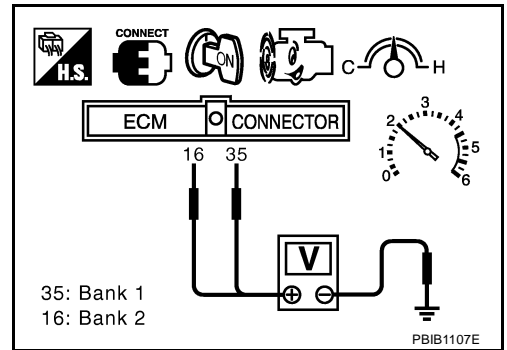

CAUTION:

- Discard any heated oxygen sensor which has been dropped from a height of more than 0.5 m (19.7 in) onto a hard surface such as a concrete floor; use a new one.
- Before installing new oxygen sensor, clean exhaust system threads using Oxygen Sensor Thread Cleaner tool J-43897-18 or J-43897-12 and approved anti-seize lubricant.

**Removal and Installation
HEATED OXYGEN SENSOR 1**

Refer to [EM-26, "EXHAUST MANIFOLD AND THREE WAY CATALYST"](#) .

ABS006NY

DTC P0133, P0153 HO2S1

PFP:22690

Component Description

ABS006NZ

The heated oxygen sensor 1 is placed into the exhaust manifold. It detects the amount of oxygen in the exhaust gas compared to the outside air. The heated oxygen sensor 1 has a closed-end tube made of ceramic zirconia. The zirconia generates voltage from approximately 1V in richer conditions to 0V in leaner conditions. The heated oxygen sensor 1 signal is sent to the ECM. The ECM adjusts the injection pulse duration to achieve the ideal air-fuel ratio. The ideal air-fuel ratio occurs near the radical change from 1 to 0V.

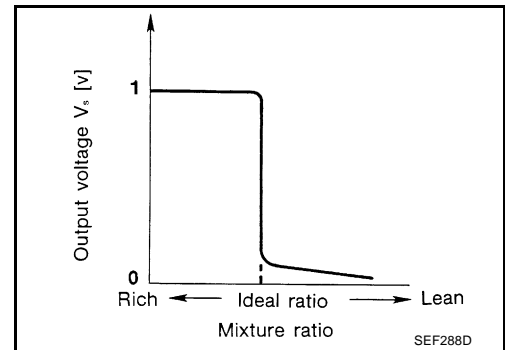
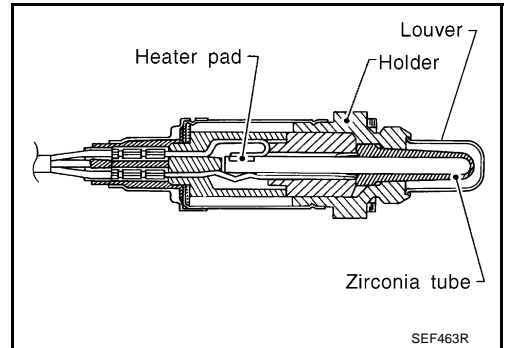

CONSULT-II Reference Value in Data Monitor Mode

ABS00600

Specification data are reference values.

MONITOR ITEM	CONDITION		SPECIFICATION
HO2S1 (B1) HO2S1 (B2)	● Engine: After warming up	Maintaining engine speed at 2,000 rpm	0 - 0.3V ↔ Approx. 0.6 - 1.0V
HO2S1 MNTR (B1) HO2S1 MNTR (B2)			LEAN ↔ RICH Changes more than 5 times during 10 seconds.

On Board Diagnosis Logic

ABS00601

To judge the malfunction of heated oxygen sensor 1, this diagnosis measures response time of heated oxygen sensor 1 signal. The time is compensated by engine operating (speed and load), fuel feedback control constant, and heated oxygen sensor 1 temperature index. Judgment is based on whether the compensated time (heated oxygen sensor 1 cycling time index) is inordinately long or not.

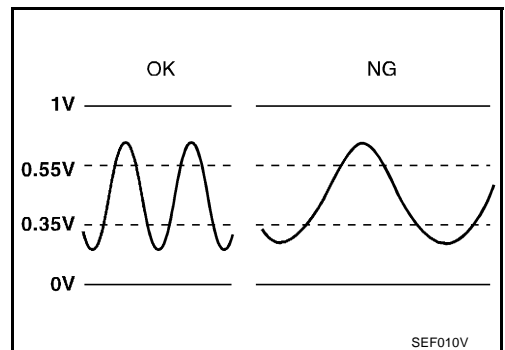

DTC No.	Trouble diagnosis name	DTC detecting condition	Possible cause
P0133 0133 (Bank 1)	Heated oxygen sensor 1 circuit slow response	The response of the voltage signal from the sensor takes more than the specified time.	<ul style="list-style-type: none"> ● Harness or connectors (The sensor circuit is open or shorted) ● Heated oxygen sensor 1 ● Fuel pressure ● Injector ● Intake air leaks ● Exhaust gas leaks ● PCV valve ● Mass air flow sensor
P0153 0153 (Bank 2)			

DTC Confirmation Procedure

ABS00602

CAUTION:

Always drive vehicle at a safe speed.

NOTE:

If DTC Confirmation Procedure has been previously conducted, always turn ignition switch OFF and wait at least 10 seconds before conducting the next test.

TESTING CONDITION:

- Always perform at a temperature above -10°C (14°F).
- Before performing the following procedure, confirm that battery voltage is more than 11V at idle.

WITH CONSULT-II

1. Start engine and warm it up to normal operating temperature.
2. Stop engine and wait at least 10 seconds.
3. Turn ignition switch ON and select "HO2S1 (B1) P0133" or "HO2S1 (B2) P0153" of "HO2S1" in "DTC WORK SUPPORT" mode with CONSULT-II.
4. Touch "START".
5. Start engine and let it idle for at least 3 minutes.

NOTE:

Never raise engine speed above 3,600 rpm after this step. If the engine speed limit is exceeded, return to step 5.

HO2S1 (B1) P0133	
OUT OF CONDITION	
MONITOR	
ENG SPEED	XXX rpm
B/FUEL SCHDL	XXX msec
COOLAN TEMP/S	XXX °C
VHCL SPEED SEN	XXX km/h

SEF338Z

6. When the following conditions are met, "TESTING" will be displayed on the CONSULT-II screen. Maintain the conditions continuously until "TESTING" changes to "COMPLETED". (It will take approximately 20 to 50 seconds.)

ENG SPEED	1,000 - 3,100 rpm
Vehicle speed	More than 80 km/h (50 MPH)
B/FUEL SCHDL	2.0 - 17.0 msec
Selector lever	Suitable position

HO2S1 (B1) P0133	
TESTING	
MONITOR	
ENG SPEED	XXX rpm
B/FUEL SCHDL	XXX msec
COOLAN TEMP/S	XXX °C
VHCL SPEED SEN	XXX km/h

SEF339Z

If "TESTING" is not displayed after 5 minutes, retry from step 2.

7. Make sure that "OK" is displayed after touching "SELF-DIAG RESULTS". If "NG" is displayed, refer to [EC-220, "Diagnostic Procedure"](#) .

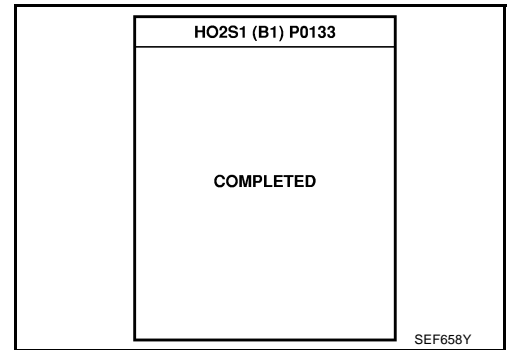

Overall Function Check

ABS00603

Use this procedure to check the overall function of the heated oxygen sensor 1 circuit. During this check, a DTC might not be confirmed.

WITH GST

1. Start engine and warm it up to normal operating temperature.
2. Set voltmeter probes between ECM terminal 35 [HO2S1(B1) signal] or 16 [HO2S1(B2) signal] and ground.
3. Check the following with engine speed held at 2,000 rpm constant under no load.
 - The voltage fluctuates between 0 to 0.3V and 0.6 to 1.0V more than 5 times within 10 seconds.

1 time: 0 - 0.3V → 0.6 - 1.0V → 0 - 0.3V
2 times: 0 - 0.3V → 0.6 - 1.0V → 0 - 0.3V → 0.6 - 1.0V
→ 0 - 0.3V
4. If NG, go to [EC-220, "Diagnostic Procedure"](#) .

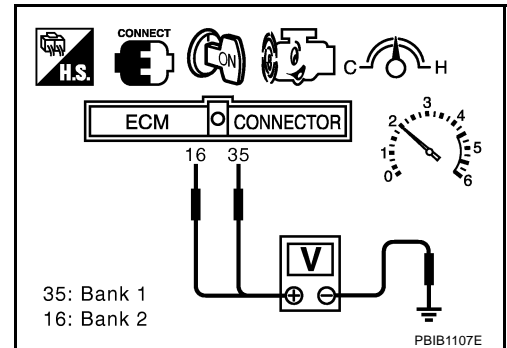

Wiring Diagram
BANK 1

EC-O2S1B1-01

— : DETECTABLE LINE FOR DTC
 — : NON-DETECTABLE LINE FOR DTC

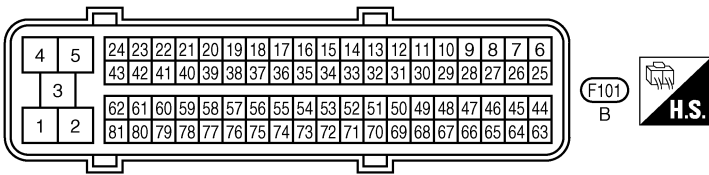
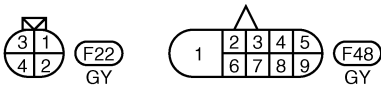
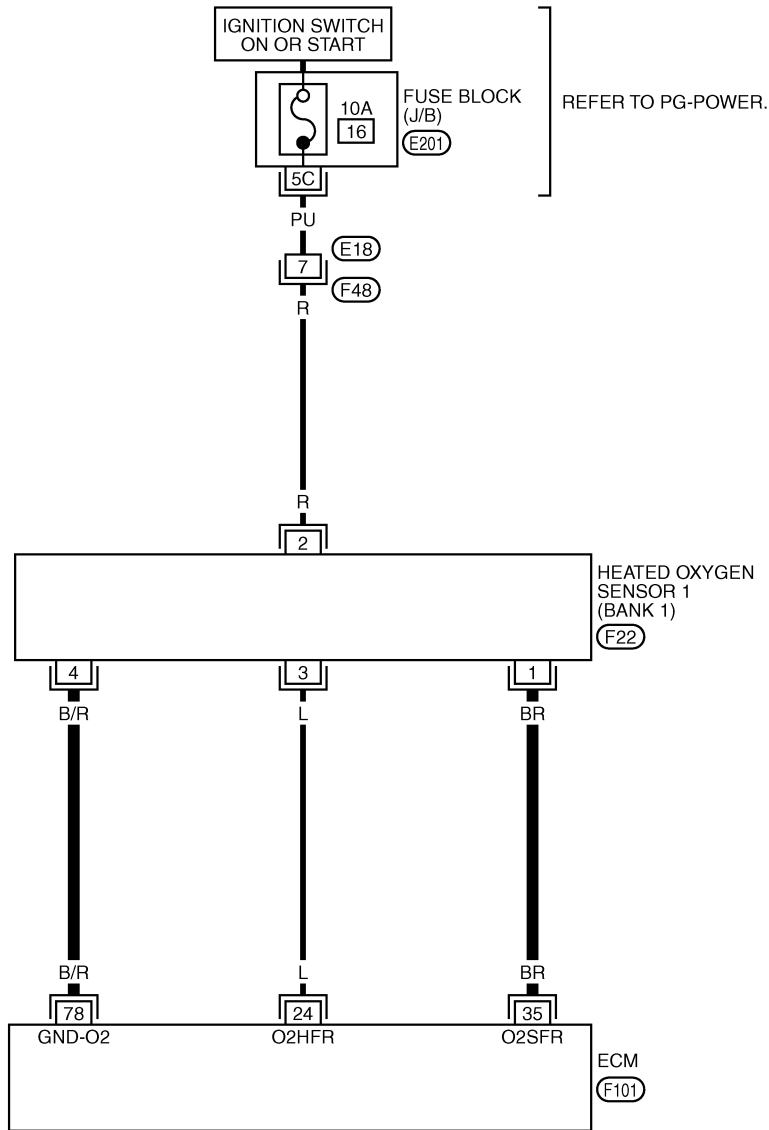

REFER TO THE FOLLOWING.
 (E201) - FUSE BLOCK-JUNCTION BOX (J/B)

DTC P0133, P0153 HO2S1

[VQ35DE]

Specification data are reference values and are measured between each terminal and ground.

CAUTION:

Do not use ECM ground terminals when measuring input/output voltage. Doing so may result in damage to the ECM's transistor. Use a ground other than ECM terminals, such as the ground.

TER-MINAL NO.	WIRE COLOR	ITEM	CONDITION	DATA (DC Voltage)
35	BR	Heated oxygen sensor 1 (bank 1)	[Engine is running] <ul style="list-style-type: none">● Warm-up condition● Engine speed is 2,000 rpm	0 - Approximately 1.0V (Periodically change)
78	B/R	Sensor ground (Heated oxygen sensor)	[Engine is running] <ul style="list-style-type: none">● Warm-up condition● Idle speed	Approximately 0V

BANK 2

EC-O2S1B2-01

— : DETECTABLE LINE FOR DTC
 — : NON-DETECTABLE LINE FOR DTC

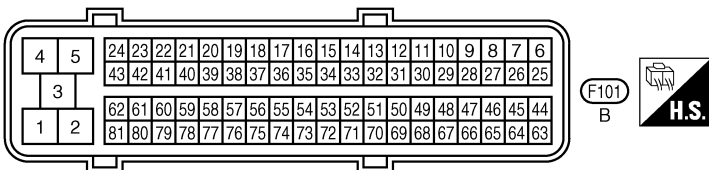
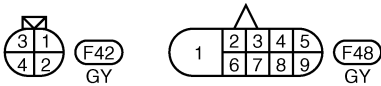
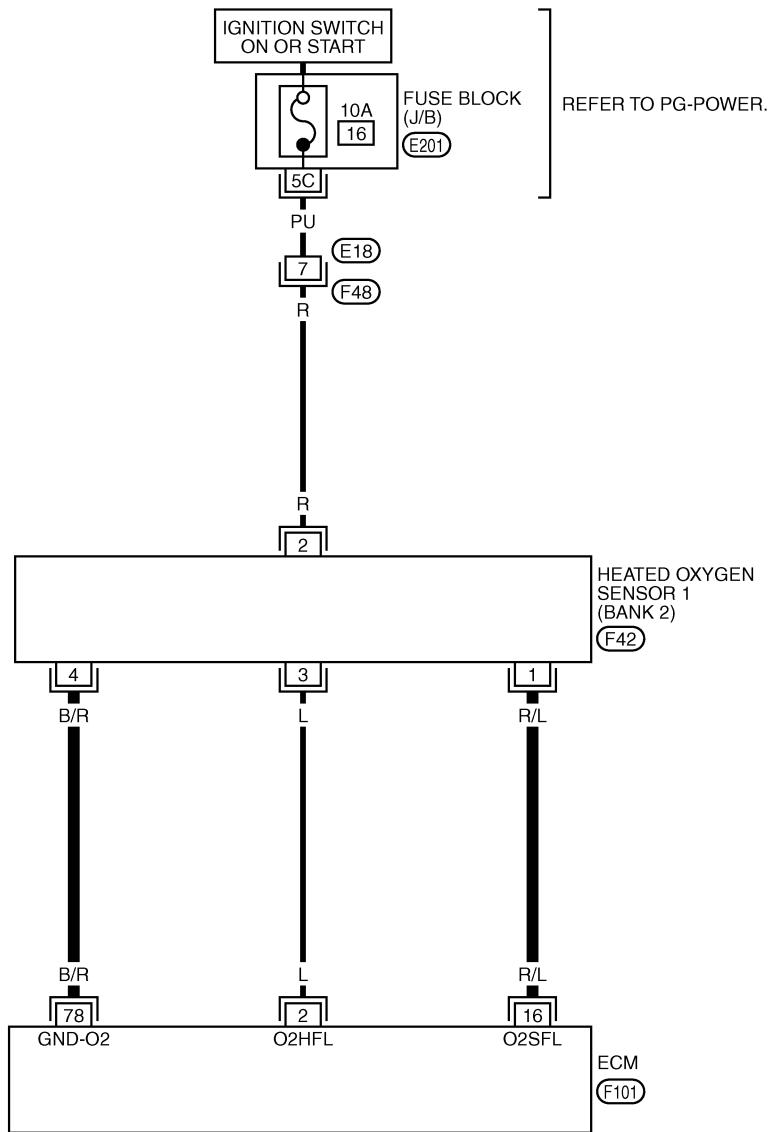

REFER TO THE FOLLOWING.
 (E201) - FUSE BLOCK-JUNCTION BOX (J/B)

Specification data are reference values and are measured between each terminal and ground.

CAUTION:

Do not use ECM ground terminals when measuring input/output voltage. Doing so may result in damage to the ECM's transistor. Use a ground other than ECM terminals, such as the ground.

TER-MINAL NO.	WIRE COLOR	ITEM	CONDITION	DATA (DC Voltage)
16	R/L	Heated oxygen sensor 1 (bank 2)	[Engine is running] <ul style="list-style-type: none"> ● Warm-up condition ● Engine speed is 2,000 rpm 	0 - Approximately 1.0V (Periodically change)
78	B/R	Sensor ground (Heated oxygen sensor)	[Engine is running] <ul style="list-style-type: none"> ● Warm-up condition ● Idle speed 	Approximately 0V

Diagnostic Procedure

ABS00605

1. CHECK GROUND CONNECTIONS

1. Turn ignition switch OFF.
2. Loosen and retighten ground three screws on the body. Refer to [EC-141, "Ground Inspection"](#).

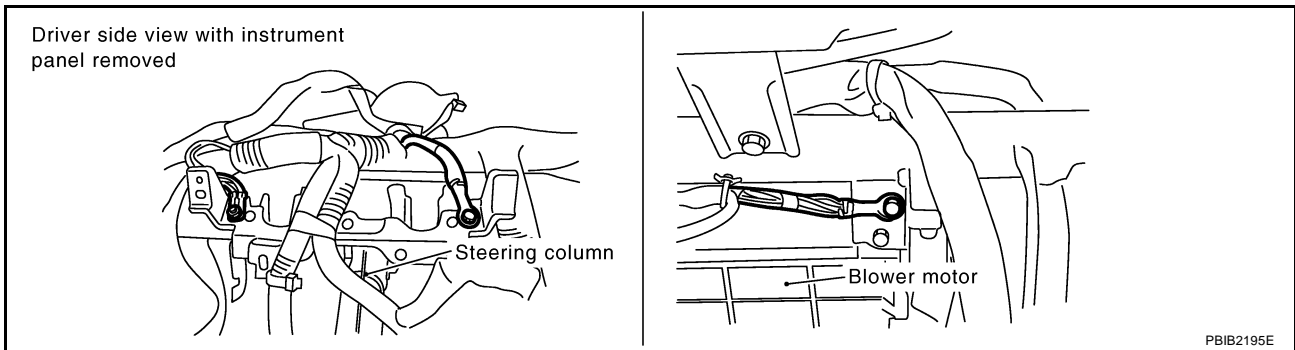

OK or NG

- OK >> GO TO 2.
- NG >> Repair or replace ground connections.

2. RETIGHTEN HEATED OXYGEN SENSOR 1

Loosen and retighten heated oxygen sensor 1.

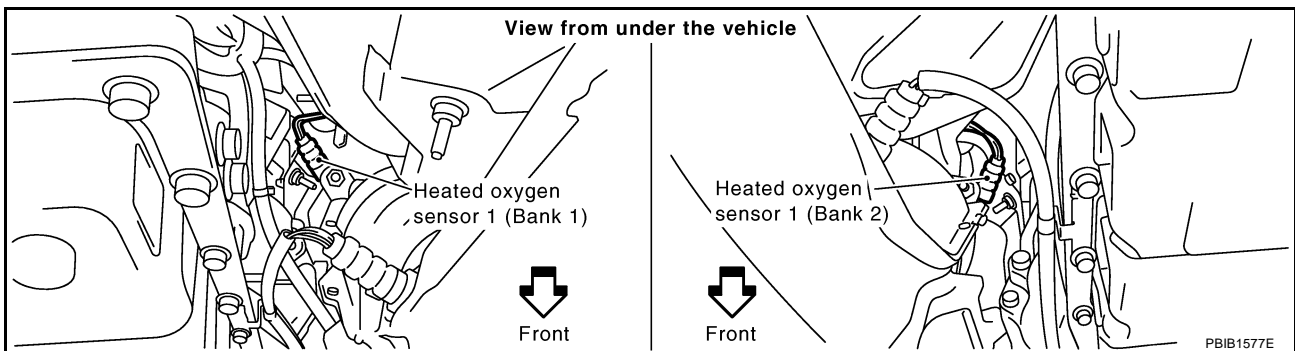

Tightening torque: 45 N·m (4.6 kg-m, 33 ft-lb)

>> GO TO 3.

3. CHECK FOR EXHAUST GAS LEAK

1. Start engine and run it at idle.
2. Listen for an exhaust gas leak before three way catalyst 1.

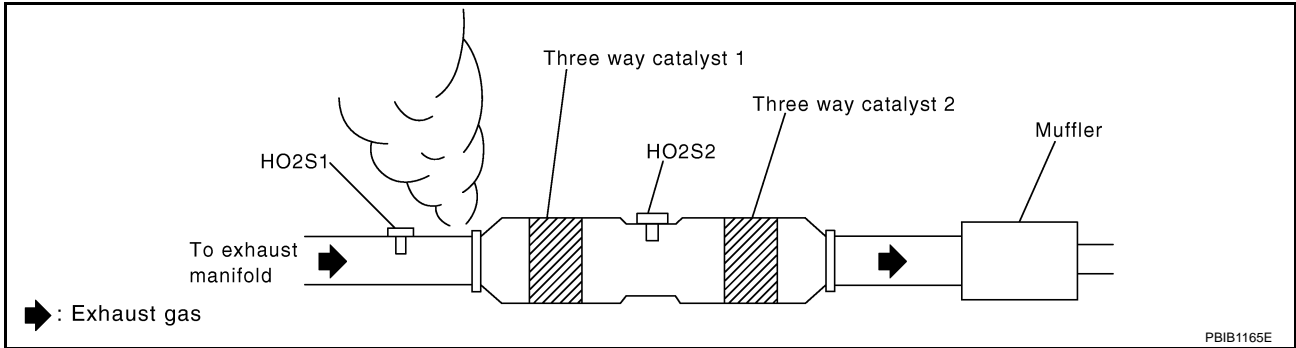

OK or NG

- OK >> GO TO 4.
 NG >> Repair or replace.

4. CHECK FOR INTAKE AIR LEAK

Listen for an intake air leak after the mass air flow sensor.

OK or NG

- OK >> GO TO 5.
 NG >> Repair or replace.

A
 EC
 C
 D
 E
 F
 G
 H
 I
 J
 K
 L
 M

5. CLEAR THE SELF-LEARNING DATA

⑧ With CONSULT-II

1. Start engine and warm it up to normal operating temperature.
2. Select "SELF-LEARNING CONT" in "WORK SUPPORT" mode with CONSULT-II.
3. Clear the self-learning control coefficient by touching "CLEAR".
4. Run engine for at least 10 minutes at idle speed.
Is the 1st trip DTC P0171, P0172, P0174 or P0175 detected?
Is it difficult to start engine?

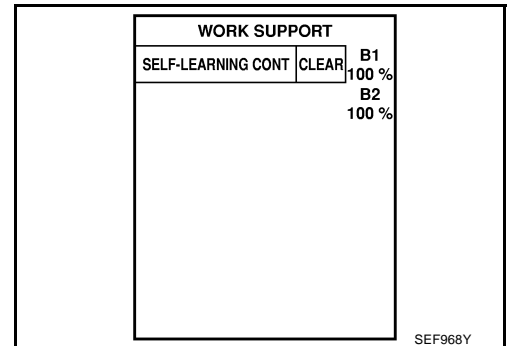

⊗ Without CONSULT-II

1. Start engine and warm it up to normal operating temperature.
2. Turn ignition switch OFF.
3. Disconnect mass air flow sensor harness connector, and restart and run engine for at least 5 seconds at idle speed.
4. Stop engine and reconnect mass air flow sensor harness connector.
5. Make sure DTC P0102 is displayed.
6. Erase the DTC memory. Refer to [EC-67, "HOW TO ERASE EMISSION-RELATED DIAGNOSTIC INFORMATION"](#).
7. Make sure DTC P0000 is displayed.
8. Run engine for at least 10 minutes at idle speed.
Is the 1st trip DTC P0171, P0172, P0174 or P0175 detected?
Is it difficult to start engine?

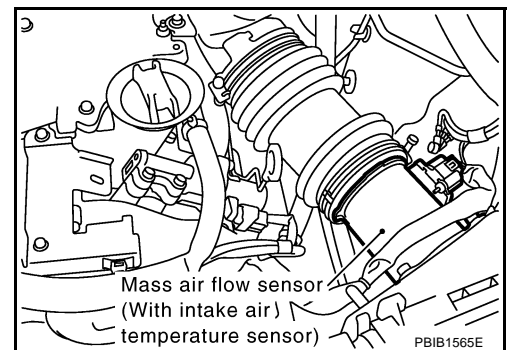

Yes or No

- Yes >> Perform trouble diagnosis for DTC P0171 or DTC P0172 (Refer to [EC-256](#) or [EC-265](#)).
- No >> GO TO 6.

6. CHECK HO2S1 GROUND CIRCUIT FOR OPEN AND SHORT

1. Turn ignition switch OFF.
2. Disconnect heated oxygen sensor 1 harness connector.

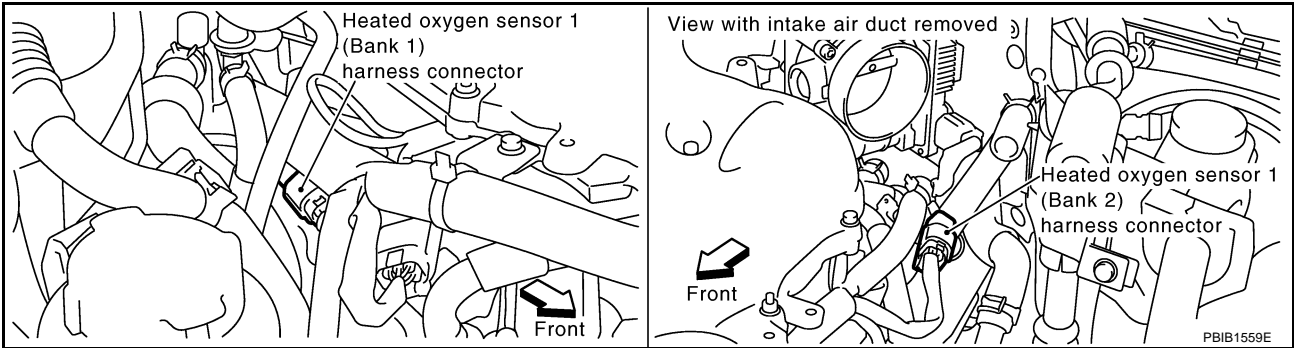

3. Disconnect ECM harness connector.
4. Check harness continuity between HO2S1 terminal 4 and ECM terminal 78. Refer to Wiring Diagram.

Continuity should exist.

5. Also check harness for short to ground and short to power.

OK or NG

OK >> GO TO 7.

NG >> Repair open circuit or short to ground or short to power in harness or connectors.

7. CHECK HO2S1 INPUT SIGNAL CIRCUIT FOR OPEN AND SHORT

1. Check harness continuity between ECM terminal and HO2S1 terminal as follows. Refer to Wiring Diagram.

DTC	Terminals		Bank
	ECM	Sensor	
P0133	35	1	1
P0153	16	1	2

Continuity should exist.

2. Check harness continuity between the following terminals and ground. Refer to Wiring Diagram.

DTC	Terminals		Bank
	ECM	Sensor	
P0133	35	1	1
P0153	16	1	2

Continuity should not exist.

3. Also check harness for short to power.

OK or NG

OK >> GO TO 8.

NG >> Repair open circuit or short to ground or short to power in harness or connectors.

8. CHECK MASS AIR FLOW SENSOR

Refer to [EC-172, "Component Inspection"](#) .

OK or NG

- OK >> GO TO 9.
 NG >> Replace mass air flow sensor.

9. CHECK PCV VALVE

Refer to [EC-655, "Component Inspection"](#) .

OK or NG

- OK >> GO TO 10.
 NG >> Replace PCV valve.

10. CHECK HEATED OXYGEN SENSOR 1

Refer to [EC-224, "Component Inspection"](#) .

OK or NG

- OK >> GO TO 11.
 NG >> Replace malfunctioning heated oxygen sensor 1.

11. CHECK INTERMITTENT INCIDENT

Refer to [EC-135, "TROUBLE DIAGNOSIS FOR INTERMITTENT INCIDENT"](#) .

>> INSPECTION END

Component Inspection HEATED OXYGEN SENSOR 1

ABS00606

 **With CONSULT-II**

1. Start engine and warm it up to normal operating temperature.
2. Select "MANU TRIG" and adjust "TRIGGER POINT" to 100% in "DATA MONITOR" mode with CONSULT-II.
3. Select "HO2S1 (B1)/(B2)" and "HO2S1 MNTR (B1)/(B2)".
4. Hold engine speed at 2,000 rpm under no load during the following steps.
5. Touch "RECORD" on CONSULT-II screen.

DATA MONITOR	
MONITOR	NO DTC
ENG SPEED	XXX rpm
MAS A/F SE-B1	XXX V
COOLAN TEMP/S	XXX °C
HO2S1 (B1)	XXX V
HO2S1 MNTR (B1)	LEAN

SEF646Y

6. Check the following.

- "HO2S1 MNTR (B1)/(B2)" in "DATA MONITOR" mode changes from "RICH" to "LEAN" to "RICH" 5 times in 10 seconds.
5 times (cycles) are counted as shown at right.
- "HO2S1 (B1)/(B2)" voltage goes above 0.6V at least once.
- "HO2S1 (B1)/(B2)" voltage goes below 0.3V at least once.
- "HO2S1 (B1)/(B2)" voltage never exceeds 1.0V.

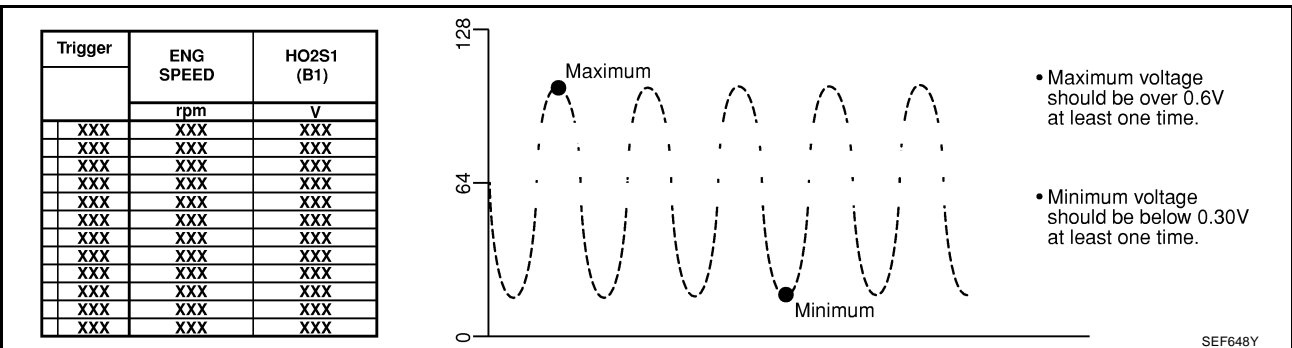
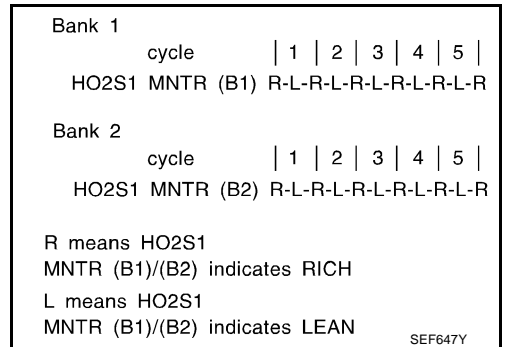

CAUTION:

- Discard any heated oxygen sensor which has been dropped from a height of more than 0.5 m (19.7 in) onto a hard surface such as a concrete floor; use a new one.
- Before installing new oxygen sensor, clean exhaust system threads using Oxygen Sensor Thread Cleaner tool J-43897-18 or J-43897-12 and approved anti-seize lubricant.

Without CONSULT-II

1. Start engine and warm it up to normal operating temperature.
 2. Set voltmeter probes between ECM terminal 35 [HO2S1 (B1) signal] or 16 [HO2S1 (B2) signal] and ground.
 3. Check the following with engine speed held at 2,000 rpm constant under no load.
 - The voltage fluctuates between 0 to 0.3V and 0.6 to 1.0V more than 5 times within 10 seconds.
 - The maximum voltage is over 0.6V at least one time.
 - The minimum voltage is below 0.3V at least one time.
 - The voltage never exceeds 1.0V.
- 1 time: 0 - 0.3V → 0.6 - 1.0V → 0 - 0.3V
2 times: 0 - 0.3V → 0.6 - 1.0V → 0 - 0.3V → 0.6 - 1.0V

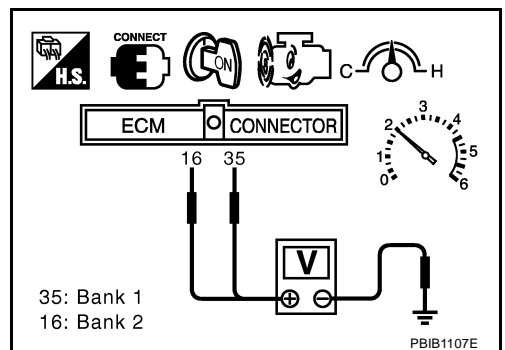

CAUTION:

- Discard any heated oxygen sensor which has been dropped from a height of more than 0.5 m (19.7 in) onto a hard surface such as a concrete floor; use a new one.
- Before installing new oxygen sensor, clean exhaust system threads using Oxygen Sensor Thread Cleaner tool J-43897-18 or J-43897-12 and approved anti-seize lubricant.

**Removal and Installation
HEATED OXYGEN SENSOR 1**

Refer to [EM-26, "EXHAUST MANIFOLD AND THREE WAY CATALYST"](#).

DTC P0134, P0154 HO2S1

PFP:22690

Component Description

ABS00608

The heated oxygen sensor 1 is placed into the exhaust manifold. It detects the amount of oxygen in the exhaust gas compared to the outside air. The heated oxygen sensor 1 has a closed-end tube made of ceramic zirconia. The zirconia generates voltage from approximately 1V in richer conditions to 0V in leaner conditions. The heated oxygen sensor 1 signal is sent to the ECM. The ECM adjusts the injection pulse duration to achieve the ideal air-fuel ratio. The ideal air-fuel ratio occurs near the radical change from 1 to 0V.

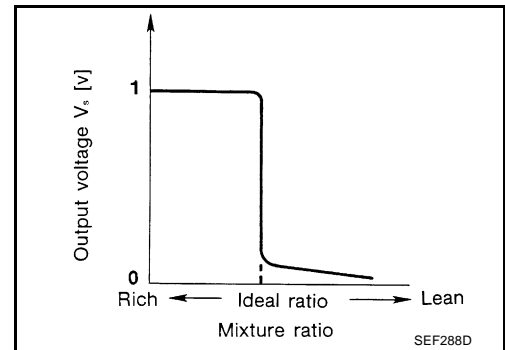
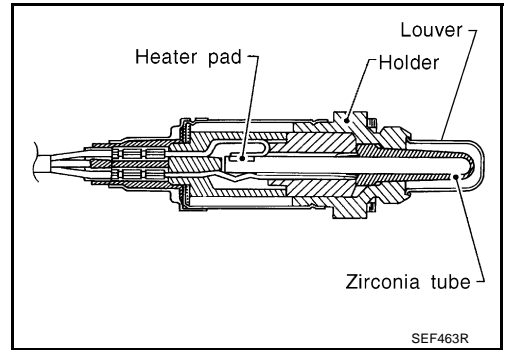

CONSULT-II Reference Value in Data Monitor Mode

ABS00609

Specification data are reference values.

MONITOR ITEM	CONDITION		SPECIFICATION
HO2S1 (B1) HO2S1 (B2)	● Engine: After warming up	Maintaining engine speed at 2,000 rpm	0 - 0.3V ↔ Approx. 0.6 - 1.0V
HO2S1 MNTR (B1) HO2S1 MNTR (B2)			LEAN ↔ RICH Changes more than 5 times during 10 seconds.

On Board Diagnosis Logic

ABS0060A

Under the condition in which the heated oxygen sensor 1 signal is not input, the ECM circuits will read a continuous approximately 0.3V. Therefore, for this diagnosis, the time that output voltage is within 200 to 400 mV range is monitored, and the diagnosis checks that this time is not inordinately long.

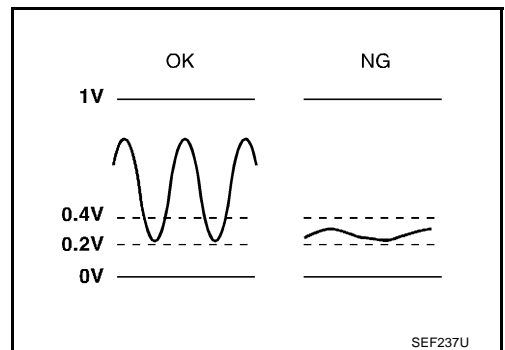

DTC No.	Trouble diagnosis name	DTC detecting condition	Possible cause
P0134 0134 (Bank 1)	Heated oxygen sensor 1 circuit no activity detected	The voltage from the sensor is constantly approx. 0.3V.	<ul style="list-style-type: none"> ● Harness or connectors (The sensor circuit is open or shorted) ● Heated oxygen sensor 1
P0154 0154 (Bank 2)			

DTC Confirmation Procedure

CAUTION:

Always drive vehicle at a safe speed.

NOTE:

If DTC Confirmation Procedure has been previously conducted, always turn ignition switch OFF and wait at least 10 seconds before conducting the next test.

TESTING CONDITION:

Before performing the following procedure, confirm that battery voltage is more than 11V at idle.

WITH CONSULT-II

1. Start engine and warm it up to normal operating temperature.
2. Select "HO2S1 (B1) P0134" or "HO2S1 (B2) P0154" of "HO2S1" in "DTC WORK SUPPORT" mode with CONSULT-II.
3. Touch "START".
4. Let it idle for at least 3 minutes.

NOTE:

Do not raise engine speed above 3,600 rpm after this step. If the engine speed limit is exceeded, return to step 4.

HO2S1 (B1) P0134	
OUT OF CONDITION	
MONITOR	
ENG SPEED	XXX rpm
B/FUEL SCHDL	XXX msec
COOLAN TEMP/S	XXX °C
VHCL SPEED SEN	XXX km/h

PBIB0544E

5. When the following conditions are met, "TESTING" will be displayed on the CONSULT-II screen. Maintain the conditions continuously until "TESTING" changes to "COMPLETED". (It will take approximately 10 to 60 seconds.)

ENG SPEED	1,200 - 3,100 rpm
Vehicle speed	More than 64 km/h (40 MPH)
B/FUEL SCHDL	2.0 - 17.0 msec
Selector lever	Suitable position

HO2S1 (B1) P0134	
TESTING	
MONITOR	
ENG SPEED	XXX rpm
B/FUEL SCHDL	XXX msec
COOLAN TEMP/S	XXX °C
VHCL SPEED SEN	XXX km/h

PBIB0545E

If "TESTING" is not displayed after 5 minutes, retry from step 2.

6. Make sure that "OK" is displayed after touching "SELF-DIAG RESULTS". If "NG" is displayed, refer to [EC-232, "Diagnostic Procedure"](#).

HO2S1 (B1) P0134	
COMPLETED	

SEC750C

Overall Function Check

Use this procedure to check the overall function of the heated oxygen sensor 1 circuit. During this check, a DTC might not be confirmed.

WITH GST

1. Start engine and warm it up to normal operating temperature.
2. Set voltmeter probes between ECM terminal 35 [HO2S1 (B1) signal] or 16 [HO2S1 (B2) signal] and ground.
3. Check the following with engine speed held at 2,000 rpm constant under no load.
 - The voltage does not remain in the range of 0.2 to 0.4V.
4. If NG, go to [EC-232, "Diagnostic Procedure"](#).

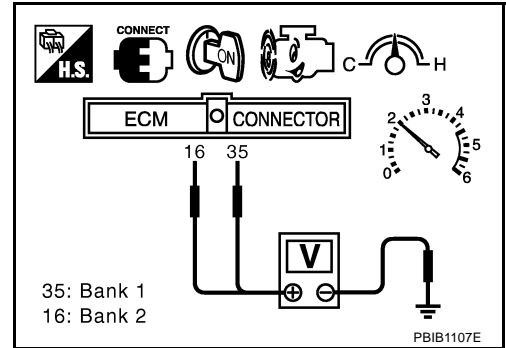

Wiring Diagram
BANK 1

EC-O2S1B1-01

— : DETECTABLE LINE FOR DTC
 — : NON-DETECTABLE LINE FOR DTC

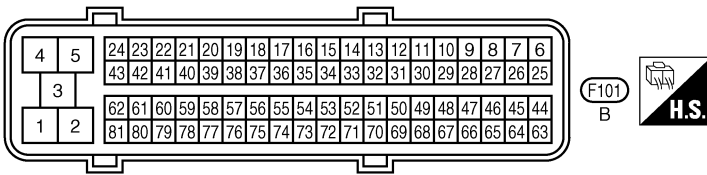
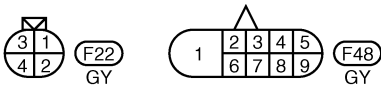
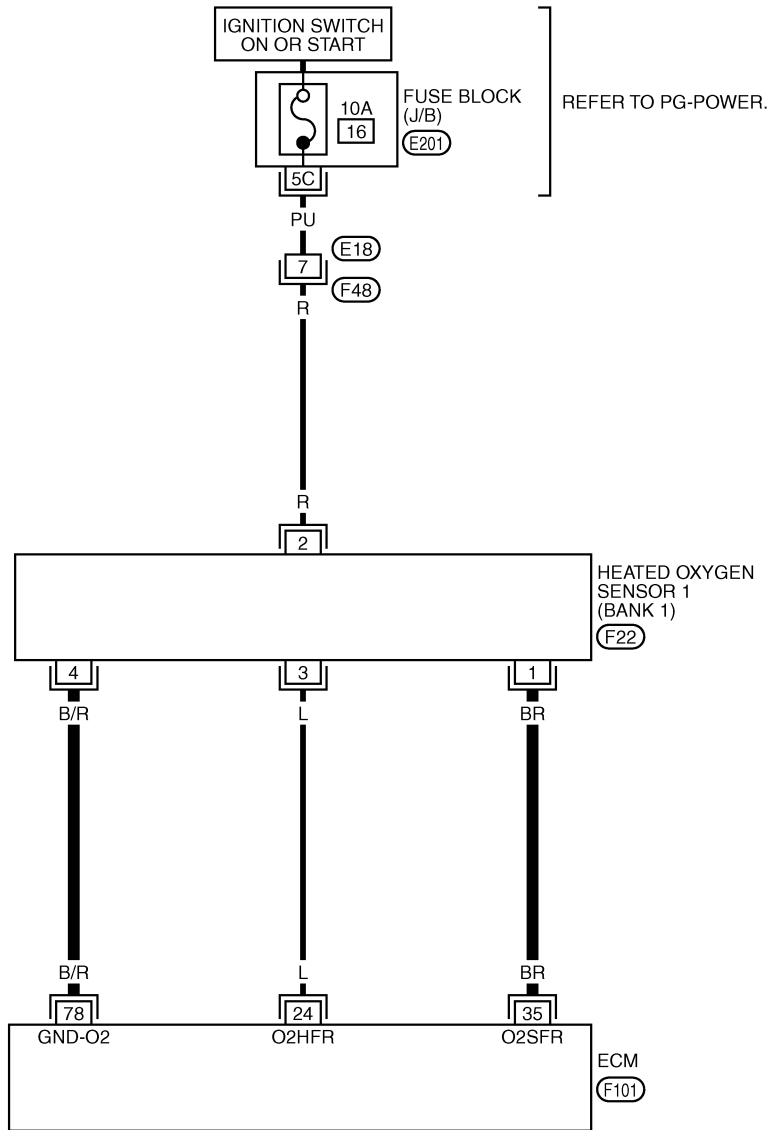

REFER TO THE FOLLOWING.
 (E201) - FUSE BLOCK-JUNCTION BOX (J/B)

A
 EC
 C
 D
 E
 F
 G
 H
 I
 J
 K
 L
 M

DTC P0134, P0154 HO2S1

[VQ35DE]

Specification data are reference values and are measured between each terminal and ground.

CAUTION:

Do not use ECM ground terminals when measuring input/output voltage. Doing so may result in damage to the ECM's transistor. Use a ground other than ECM terminals, such as the ground.

TER-MINAL NO.	WIRE COLOR	ITEM	CONDITION	DATA (DC Voltage)
35	BR	Heated oxygen sensor 1 (bank 1)	[Engine is running] <ul style="list-style-type: none">● Warm-up condition● Engine speed is 2,000 rpm	0 - Approximately 1.0V (Periodically change)
78	B/R	Sensor ground (Heated oxygen sensor)	[Engine is running] <ul style="list-style-type: none">● Warm-up condition● Idle speed	Approximately 0V

BANK 2

EC-O2S1B2-01

— : DETECTABLE LINE FOR DTC
 — : NON-DETECTABLE LINE FOR DTC

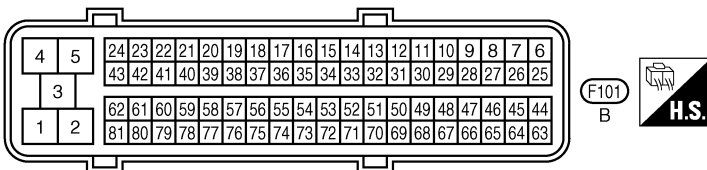
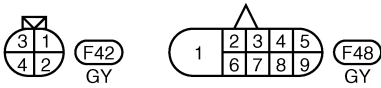
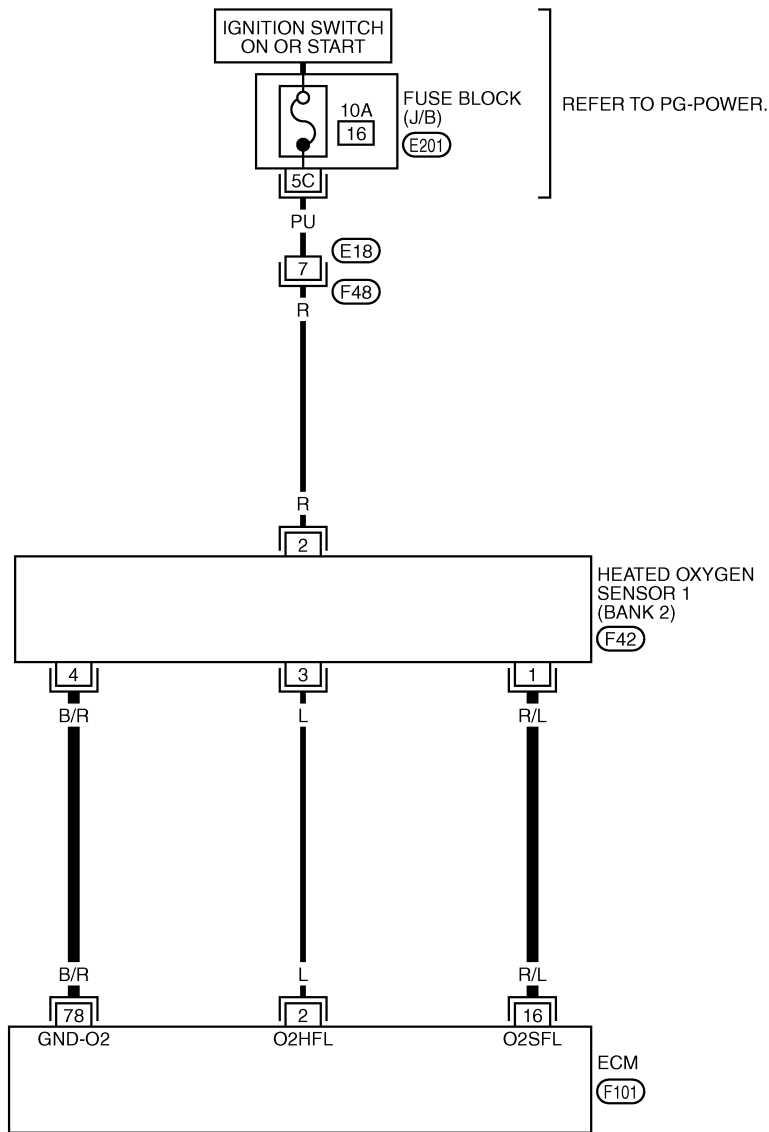

REFER TO THE FOLLOWING.
 (E201) - FUSE BLOCK-JUNCTION BOX (J/B)

Specification data are reference values and are measured between each terminal and ground.

CAUTION:

Do not use ECM ground terminals when measuring input/output voltage. Doing so may result in damage to the ECM's transistor. Use a ground other than ECM terminals, such as the ground.

TER-MINAL NO.	WIRE COLOR	ITEM	CONDITION	DATA (DC Voltage)
16	R/L	Heated oxygen sensor 1 (bank 2)	[Engine is running] <ul style="list-style-type: none"> ● Warm-up condition ● Engine speed is 2,000 rpm 	0 - Approximately 1.0V (Periodically change)
78	B/R	Sensor ground (Heated oxygen sensor)	[Engine is running] <ul style="list-style-type: none"> ● Warm-up condition ● Idle speed 	Approximately 0V

Diagnostic Procedure

ABS0060E

1. CHECK GROUND CONNECTIONS

1. Turn ignition switch OFF.
2. Loosen and retighten ground three screws on the body. Refer to [EC-141, "Ground Inspection"](#).

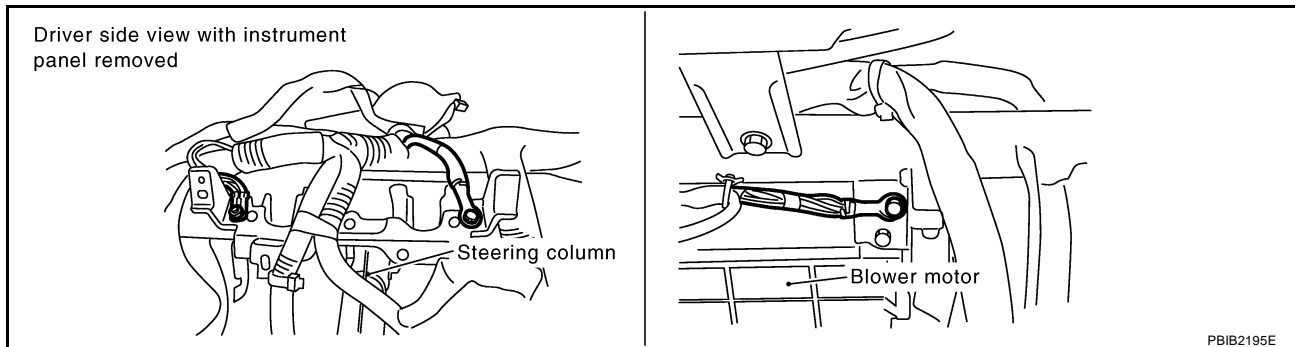
**OK or NG**

- OK >> GO TO 2.
 NG >> Repair or replace ground connections.

2. CHECK HO2S1 GROUND CIRCUIT FOR OPEN AND SHORT

1. Disconnect heated oxygen sensor 1 harness connector.

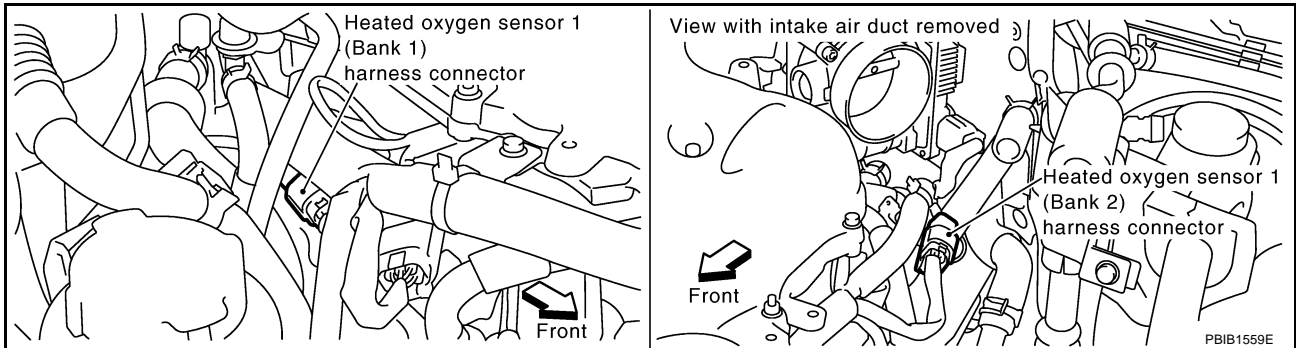

2. Disconnect ECM harness connector.
3. Check harness continuity between HO2S1 terminal 4 and ECM terminal 78.
Refer to Wiring Diagram.

Continuity should exist.

4. Also check harness for short to ground and short to power.

OK or NG

OK >> GO TO 3.

NG >> Repair open circuit or short to ground or short to power in harness or connectors.

3. CHECK HO2S1 INPUT SIGNAL CIRCUIT FOR OPEN AND SHORT

1. Disconnect ECM harness connector.
2. Check harness continuity between ECM terminal and HO2S1 terminal as follows.
Refer to Wiring Diagram.

DTC	Terminals		Bank
	ECM	Sensor	
P0134	35	1	1
P0154	16	1	2

Continuity should exist.

3. Check harness continuity between the following terminals and ground.
Refer to Wiring Diagram.

DTC	Terminals		Bank
	ECM	Sensor	
P0134	35	1	1
P0154	16	1	2

Continuity should not exist.

4. Also check harness for short to power.

OK or NG

OK >> GO TO 4.

NG >> Repair open circuit or short to ground or short to power in harness or connectors.

4. CHECK HEATED OXYGEN SENSOR 1

Refer to [EC-234, "Component Inspection"](#) .

OK or NG

- OK >> GO TO 5.
- NG >> Replace malfunctioning heated oxygen sensor 1.

5. CHECK INTERMITTENT INCIDENT

Refer to [EC-135, "TROUBLE DIAGNOSIS FOR INTERMITTENT INCIDENT"](#) .

>> INSPECTION END

Component Inspection HEATED OXYGEN SENSOR 1

ABS0060F

With CONSULT-II

1. Start engine and warm it up to normal operating temperature.
2. Select "MANU TRIG" and adjust "TRIGGER POINT" to 100% in "DATA MONITOR" mode with CONSULT-II.
3. Select "HO2S1 (B1)/(B2)" and "HO2S1 MNTR (B1)/(B2)".
4. Hold engine speed at 2,000 rpm under no load during the following steps.
5. Touch "RECORD" on CONSULT-II screen.

DATA MONITOR	
MONITOR	NO DTC
ENG SPEED	XXX rpm
MAS A/F SE-B1	XXX V
COOLANTEMP/S	XXX °C
HO2S1 (B1)	XXX V
HO2S1 MNTR (B1)	LEAN

SEF646Y

6. Check the following.

- "HO2S1 MNTR (B1)/(B2)" in "DATA MONITOR" mode changes from "RICH" to "LEAN" to "RICH" 5 times in 10 seconds.
5 times (cycles) are counted as shown at right.
- "HO2S1 (B1)/(B2)" voltage goes above 0.6V at least once.
- "HO2S1 (B1)/(B2)" voltage goes below 0.3V at least once.
- "HO2S1 (B1)/(B2)" voltage never exceeds 1.0V.

Bank 1	cycle	1	2	3	4	5	
	HO2S1 MNTR (B1)	R	L	R	L	R	L
Bank 2	cycle	1	2	3	4	5	
	HO2S1 MNTR (B2)	R	L	R	L	R	L

R means HO2S1
MNTR (B1)/(B2) indicates RICH
L means HO2S1
MNTR (B1)/(B2) indicates LEAN

SEF647Y

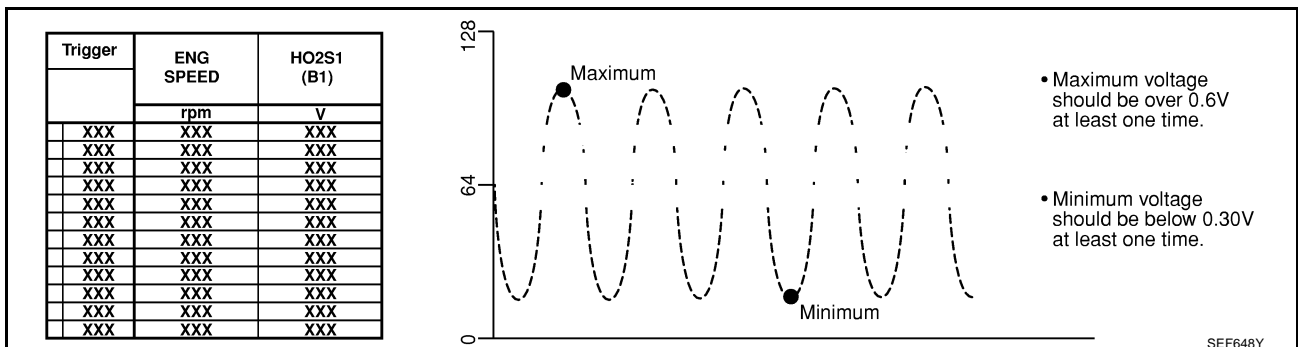

CAUTION:

- Discard any heated oxygen sensor which has been dropped from a height of more than 0.5 m (19.7 in) onto a hard surface such as a concrete floor; use a new one.
- Before installing new oxygen sensor, clean exhaust system threads using Oxygen Sensor Thread Cleaner tool J-43897-18 or J-43897-12 and approved anti-seize lubricant.

⊗ **Without CONSULT-II**

1. Start engine and warm it up to normal operating temperature.
2. Set voltmeter probes between ECM terminal 35 [HO2S1 (B1) signal] or 16 [HO2S1 (B2) signal] and ground.
3. Check the following with engine speed held at 2,000 rpm constant under no load.
 - The voltage fluctuates between 0 to 0.3V and 0.6 to 1.0V more than 5 times within 10 seconds.
 - The maximum voltage is over 0.6V at least one time.
 - The minimum voltage is below 0.3V at least one time.
 - The voltage never exceeds 1.0V.

1 time: 0 - 0.3V → 0.6 - 1.0V → 0 - 0.3V
 2 times: 0 - 0.3V → 0.6 - 1.0V → 0 - 0.3V → 0.6 - 1.0V

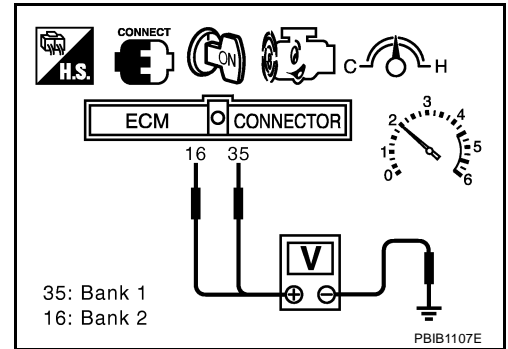
**CAUTION:**

- Discard any heated oxygen sensor which has been dropped from a height of more than 0.5 m (19.7 in) onto a hard surface such as a concrete floor; use a new one.
- Before installing new oxygen sensor, clean exhaust system threads using Oxygen Sensor Thread Cleaner tool J-43897-18 or J-43897-12 and approved anti-seize lubricant.

Removal and Installation

HEATED OXYGEN SENSOR 1

ABS0060G

Refer to [EM-26, "EXHAUST MANIFOLD AND THREE WAY CATALYST"](#).

DTC P0138, P0158 HO2S2

PFP:226A0

Component Description

ABS0060H

The heated oxygen sensor 2, after three way catalyst 1, monitors the oxygen level in the exhaust gas on each bank.

Even if switching characteristics of the heated oxygen sensor 1 are shifted, the air-fuel ratio is controlled to stoichiometric, by the signal from the heated oxygen sensor 2.

This sensor is made of ceramic zirconia. The zirconia generates voltage from approximately 1V in richer conditions to 0V in leaner conditions.

Under normal conditions the heated oxygen sensor 2 is not used for engine control operation.

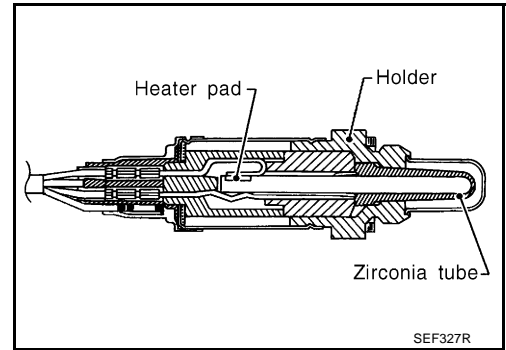

CONSULT-II Reference Value in Data Monitor Mode

ABS0060J

Specification data are reference values.

MONITOR ITEM	CONDITION		SPECIFICATION
HO2S2 (B1) HO2S2 (B2)	<ul style="list-style-type: none"> ● Warm-up condition ● After keeping engine speed between 3,500 and 4,000 rpm for 1 minute and at idle for 1 minute under no load. 	Revsing engine from idle to 3,000 rpm quickly.	0 - 0.3V ↔ Approx. 0.6 - 1.0V
HO2S2 MNTR (B1) HO2S2 MNTR (B2)			LEAN ↔ RICH

On Board Diagnosis Logic

ABS0060J

The heated oxygen sensor 2 has a much longer switching time between rich and lean than the heated oxygen sensor 1. The oxygen storage capacity of the three way catalyst 1 causes the longer switching time. To judge the malfunctions of heated oxygen sensor 2, ECM monitors whether the voltage is unusually high during the various driving condition such as fuel-cut.

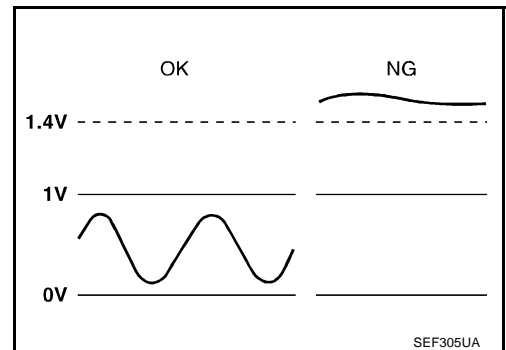

DTC No.	Trouble diagnosis name	DTC detecting condition	Possible cause
P0138 0138 (Bank 1)	Heated oxygen sensor 2 circuit high voltage	An excessively high voltage from the sensor is sent to ECM.	<ul style="list-style-type: none"> ● Harness or connectors (The sensor circuit is open or shorted) ● Heated oxygen sensor 2
P0158 0158 (Bank 2)			

DTC Confirmation Procedure**NOTE:**

If DTC Confirmation Procedure has been previously conducted, always turn ignition switch OFF and wait at least 10 seconds before conducting the next test.

Ⓟ WITH CONSULT-II

1. Turn ignition switch ON and select "DATA MONITOR" mode with CONSULT-II.
2. Start engine and warm it up to the normal operating temperature.
3. Turn ignition switch OFF and wait at least 10 seconds.
4. Start engine and keep the engine speed between 3,500 and 4,000 rpm for at least 1 minute under no load.
5. Let engine idle for 2 minutes.
6. If 1st trip DTC is detected, go to [EC-137, "Diagnostic Procedure"](#)

DATA MONITOR	
MONITOR	NO DTC
ENG SPEED	XXX rpm
COOLAN TEMP/S	XXX °C

SEF174Y

Ⓟ WITH GST

Follow the procedure "WITH CONSULT-II" above.

A

EC

C

D

E

F

G

H

I

J

K

L

M

Wiring Diagram
BANK 1

EC-O2S2B1-01

— : DETECTABLE LINE FOR DTC
— : NON-DETECTABLE LINE FOR DTC

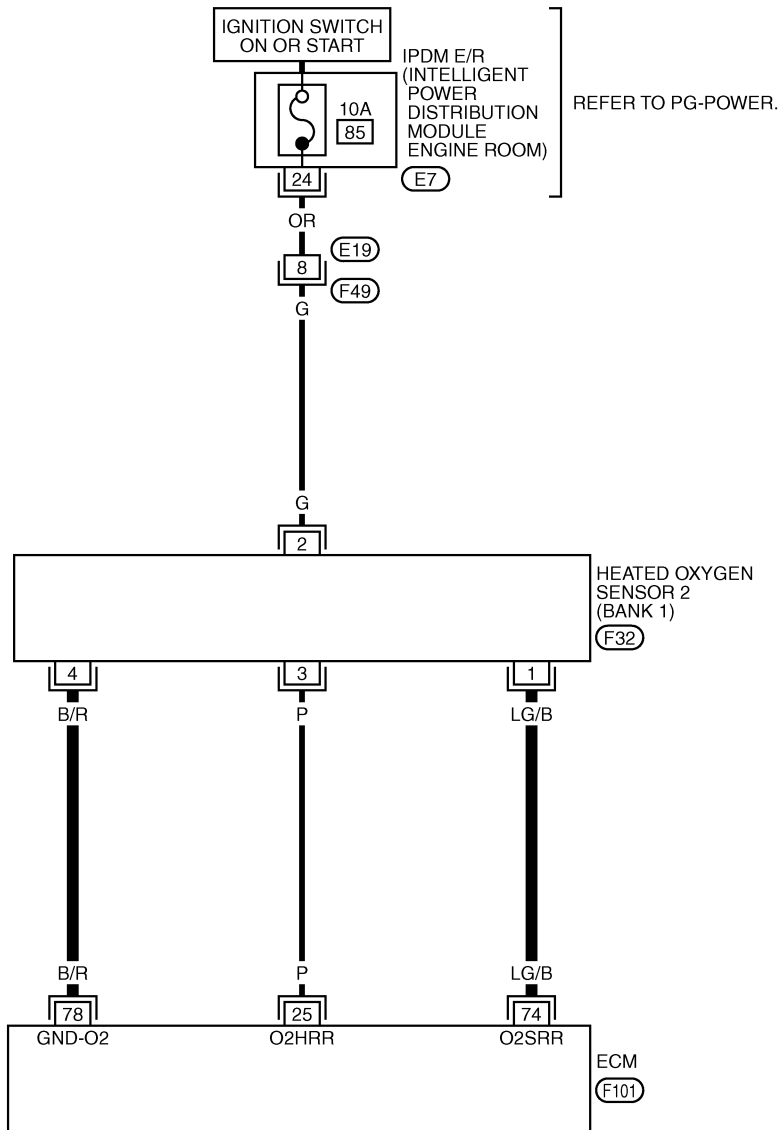

23	22	21	20	19	18	17		
32	31	30	29	28	27	26	25	24

(E7)
GY



3	1
4	2

(F32)
B

1	2	3	4
5	6	7	8

(F49)
B

4	5	24	23	22	21	20	19	18	17	16	15	14	13	12	11	10	9	8	7	6
	3	43	42	41	40	39	38	37	36	35	34	33	32	31	30	29	28	27	26	25
		62	61	60	59	58	57	56	55	54	53	52	51	50	49	48	47	46	45	44
1	2	81	80	79	78	77	76	75	74	73	72	71	70	69	68	67	66	65	64	63

(F101)
B



DTC P0138, P0158 HO2S2

[VQ35DE]

Specification data are reference values and are measured between each terminal and ground.

CAUTION:

Do not use ECM ground terminals when measuring input/output voltage. Doing so may result in damage to the ECM's transistor. Use a ground other than ECM terminals, such as the ground.

TER-MINAL NO.	WIRE COLOR	ITEM	CONDITION	DATA (DC Voltage)
74	LG/B	Heated oxygen sensor 2 (bank 1)	[Engine is running] <ul style="list-style-type: none"> ● Warm-up condition ● Revving engine from idle to 3,000 rpm quickly after the following conditions are met <ul style="list-style-type: none"> – After keeping the engine speed between 3,500 and 4,000 rpm for 1 minute and at idle for 1 minute under no load 	0 - Approximately 1.0V
78	B/R	Sensor ground (Heated oxygen sensor)	[Engine is running] <ul style="list-style-type: none"> ● Warm-up condition ● Idle speed 	Approximately 0V

A
EC
C
D
E
F
G
H
I
J
K
L
M

BANK 2

EC-O2S2B2-01

— : DETECTABLE LINE FOR DTC
 — : NON-DETECTABLE LINE FOR DTC

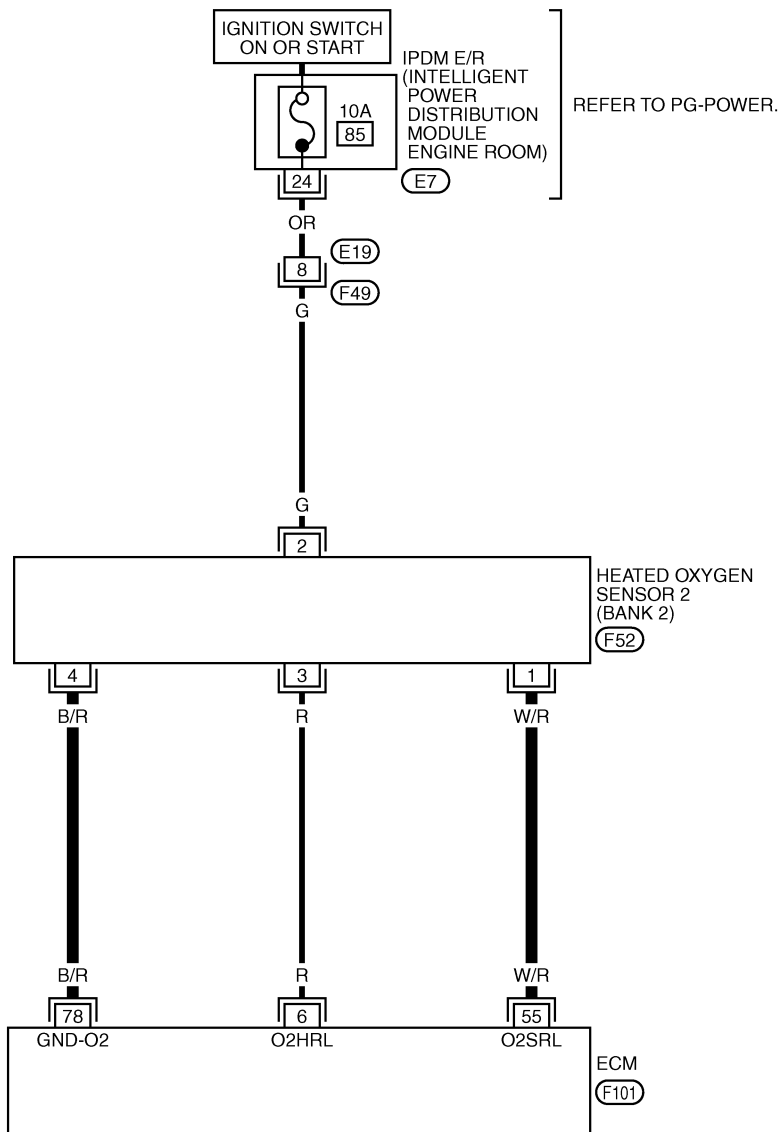

23	22	21	20	19	18	17		
32	31	30	29	28	27	26	25	24

E7 GY

1	2	3	4
5	6	7	8

F49 B

3	1
4	2

F52 GY

4	5	24	23	22	21	20	19	18	17	16	15	14	13	12	11	10	9	8	7	6
3		43	42	41	40	39	38	37	36	35	34	33	32	31	30	29	28	27	26	25
1	2	62	61	60	59	58	57	56	55	54	53	52	51	50	49	48	47	46	45	44
		81	80	79	78	77	76	75	74	73	72	71	70	69	68	67	66	65	64	63

F101 B

Specification data are reference values and are measured between each terminal and ground.

CAUTION:

Do not use ECM ground terminals when measuring input/output voltage. Doing so may result in damage to the ECM's transistor. Use a ground other than ECM terminals, such as the ground.

TER-MINAL NO.	WIRE COLOR	ITEM	CONDITION	DATA (DC Voltage)
55	W/R	Heated oxygen sensor 2 (bank 2)	<p>[Engine is running]</p> <ul style="list-style-type: none"> ● Warm-up condition ● Revving engine from idle to 3,000 rpm quickly after the following conditions are met – After keeping the engine speed between 3,500 and 4,000 rpm for 1 minute and at idle for 1 minute under no load 	0 - Approximately 1.0V
78	B/R	Sensor ground (Heated oxygen sensor)	<p>[Engine is running]</p> <ul style="list-style-type: none"> ● Warm-up condition ● Idle speed 	Approximately 0V

Diagnostic Procedure

ABS00CH2

1. CHECK GROUND CONNECTIONS

1. Turn ignition switch OFF.
2. Loosen and retighten ground three screws on the body. Refer to [EC-141, "Ground Inspection"](#).

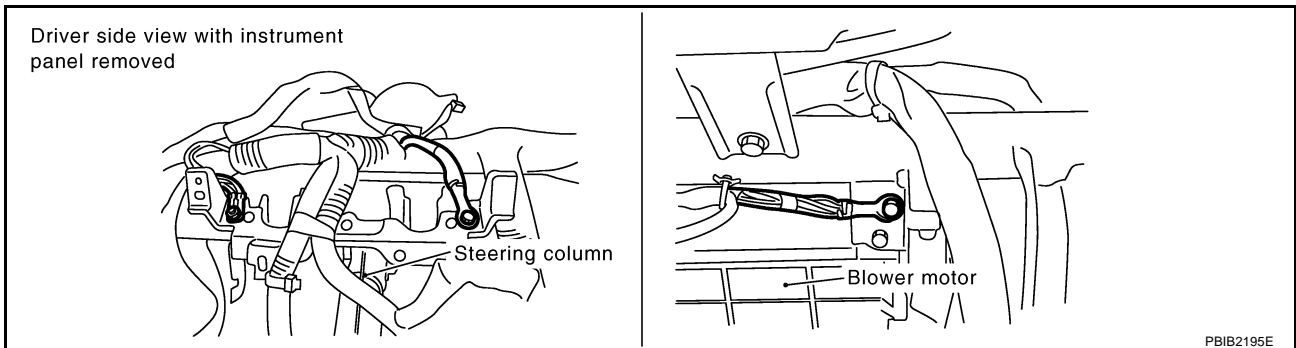

OK or NG

- OK >> GO TO 2.
- NG >> Repair or replace ground connections.

2. CHECK HO2S2 GROUND CIRCUIT FOR OPEN AND SHORT

1. Disconnect heated oxygen sensor 2 harness connector.
2. Disconnect ECM harness connector.
3. Check harness continuity between HO2S2 terminal 4 and ECM terminal 78. Refer to Wiring Diagram.

Continuity should exist.

4. Also check harness for short to ground and short to power.

OK or NG

- OK >> GO TO 3.
- NG >> Repair open circuit or short to ground or short to ground or short to power in harness or connectors.

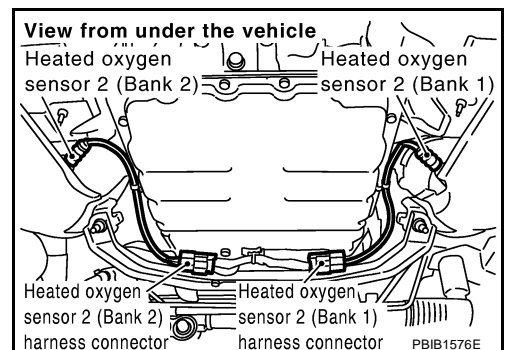

3. CHECK HO2S2 INPUT SIGNAL CIRCUIT FOR OPEN AND SHORT

1. Check harness continuity between ECM terminal and HO2S2 terminal as follows.
Refer to Wiring Diagram.

DTC	Terminals		Bank
	ECM	Sensor	
P0138	74	1	1
P0158	55	1	2

Continuity should exist.

2. Check harness continuity between the following terminals and ground.
Refer to Wiring Diagram.

DTC	Terminals		Bank
	ECM	Sensor	
P0138	74	1	1
P0158	55	1	2

Continuity should not exist.

3. Also check harness for short to power.

OK or NG

OK >> GO TO 4.

NG >> Repair open circuit or short to ground or short to power in harness or connectors.

4. CHECK HO2S2 CONNECTOR FOR WATER

Check connectors for water.

Water should not exist.

OK or NG

OK >> GO TO 5.

NG >> Repair or replace harness or connectors.

5. CHECK HEATED OXYGEN SENSOR 2

Refer to [EC-243, "Component Inspection"](#) .

OK or NG

OK >> GO TO 6.

NG >> Replace malfunctioning heated oxygen sensor 2.

6. CHECK INTERMITTENT INCIDENT

Refer to [EC-135, "TROUBLE DIAGNOSIS FOR INTERMITTENT INCIDENT"](#) .

>> **INSPECTION END**

Component Inspection
HEATED OXYGEN SENSOR 2

With CONSULT-II

1. Turn ignition switch ON and select "DATA MONITOR" mode with CONSULT-II.
2. Start engine and warm it up to the normal operating temperature.
3. Turn ignition switch OFF and wait at least 10 seconds.
4. Start engine and keep the engine speed between 3,500 and 4,000 rpm for at least 1 minute under no load.
5. Let engine idle for 1 minute.

DATA MONITOR	
MONITOR	NO DTC
ENG SPEED	XXX rpm
COOLAN TEMP/S	XXX °C

SEF174Y

6. Select "FUEL INJECTION" in "ACTIVE TEST" mode, and select "HO2S2 (B1)/(B2)" as the monitor item with CONSULT-II.

ACTIVE TEST	
FUEL INJECTION	25 %
MONITOR	
ENG SPEED	XXX rpm
HO2S1 (B1)	XXX V
HO2S2 (B1)	XXX V
HO2S1 MNTR (B1)	RICH
HO2S2 MNTR (B1)	RICH

SEF662Y

7. Check "HO2S2 (B1)/(B2)" at idle speed when adjusting "FUEL INJECTION" to $\pm 25\%$.

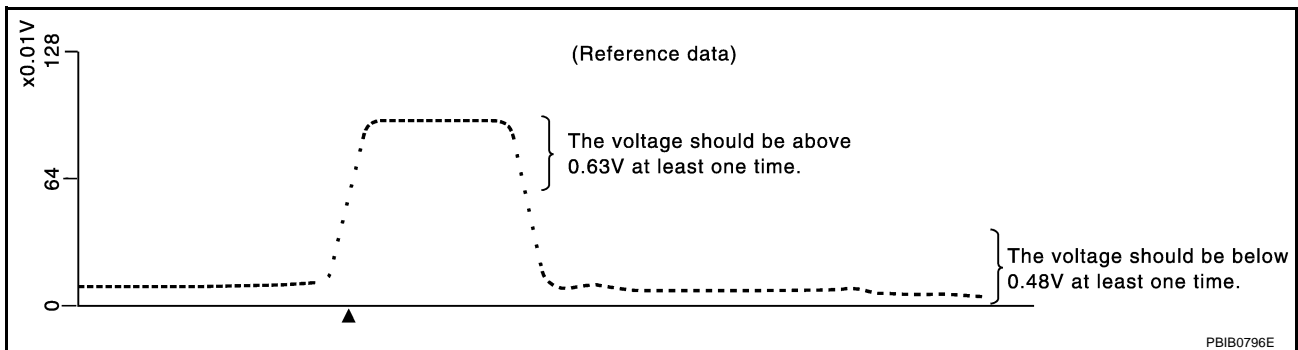

"HO2S2 (B1)/(B2)" should be above 0.63V at least once when the "FUEL INJECTION" is +25%.
 "HO2S2 (B1)/(B2)" should be below 0.48V at least once when the "FUEL INJECTION" is -25%.

CAUTION:

- Discard any heated oxygen sensor which has been dropped from a height of more than 0.5 m (19.7 in) onto a hard surface such as a concrete floor; use a new one.
- Before installing new oxygen sensor, clean exhaust system threads (using Oxygen Sensor Thread Cleaner tool J-43897-18 or J-43897-12) and approved anti-seize lubricant.

Without CONSULT-II

1. Start engine and warm it up to the normal operating temperature.
2. Turn ignition switch OFF and wait at least 10 seconds.
3. Start engine and keep the engine speed between 3,500 and 4,000 rpm for at least 1 minute under no load.
4. Let engine idle for 1 minute.
5. Set voltmeter probes between ECM terminal 74 [HO2S2 (B1) signal] or 55 [HO2S2 (B2) signal] and ground.

6. Check the voltage when revving up to 4,000 rpm under no load at least 10 times.
(Depress and release accelerator pedal as soon as possible.)
The voltage should be above 0.63V at least once during this procedure.
If the voltage is above 0.63V at step 6, step 7 is not necessary.
7. Keep vehicle at idling for 10 minutes, then check voltage. Or check the voltage when coasting from 80 km/h (50 MPH) in D position with "OD" OFF.
The voltage should be below 0.48V at least once during this procedure.
8. If NG, replace heated oxygen sensor 2.

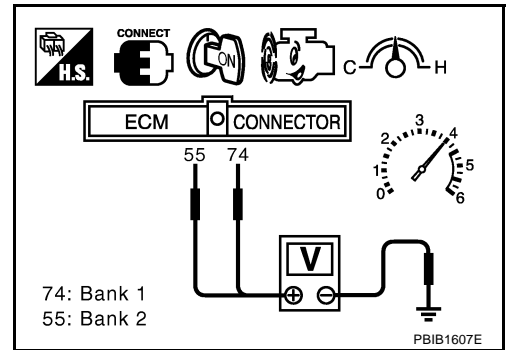
**CAUTION:**

- Discard any heated oxygen sensor which has been dropped from a height of more than 0.5 m (19.7 in) onto a hard surface such as a concrete floor; use a new one.
- Before installing new oxygen sensor, clean exhaust system threads using Oxygen Sensor Thread Cleaner tool J-43897-18 or J-43897-12 and approved anti-seize lubricant.

Removal and Installation

HEATED OXYGEN SENSOR 2

ABS00600

Refer to [EM-26, "EXHAUST MANIFOLD AND THREE WAY CATALYST"](#) .

DTC P0139, P0159 HO2S2

PFP:226A0

Component Description

ABS0060P

The heated oxygen sensor 2, after three way catalyst 1, monitors the oxygen level in the exhaust gas on each bank.

Even if switching characteristics of the heated oxygen sensor 1 are shifted, the air-fuel ratio is controlled to stoichiometric, by the signal from the heated oxygen sensor 2.

This sensor is made of ceramic zirconia. The zirconia generates voltage from approximately 1V in richer conditions to 0V in leaner conditions.

Under normal conditions the heated oxygen sensor 2 is not used for engine control operation.

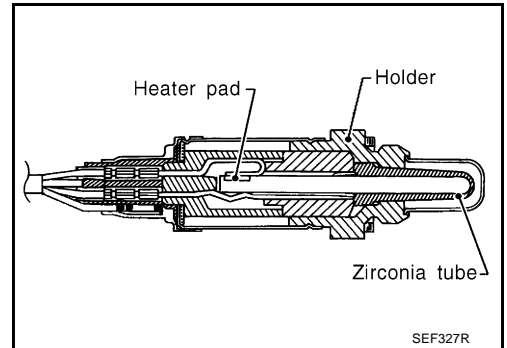

CONSULT-II Reference Value in Data Monitor Mode

ABS0060Q

Specification data are reference values.

MONITOR ITEM	CONDITION		SPECIFICATION
HO2S2 (B1) HO2S2 (B2)	<ul style="list-style-type: none"> ● Warm-up condition ● After keeping engine speed between 3,500 and 4,000 rpm for 1 minute and at idle for 1 minute under no load. 	Revving engine from idle to 3,000 rpm quickly.	0 - 0.3V ↔ Approx. 0.6 - 1.0V
HO2S2 MNTR (B1) HO2S2 MNTR (B2)			LEAN ↔ RICH

On Board Diagnosis Logic

ABS0060R

The heated oxygen sensor 2 has a much longer switching time between rich and lean than the heated oxygen sensor 1. The oxygen storage capacity before the three way catalyst 1 causes the longer switching time. To judge the malfunctions of heated oxygen sensor 2, ECM monitors whether the switching response of the sensor's voltage is faster than specified during the various driving condition such as fuel-cut.

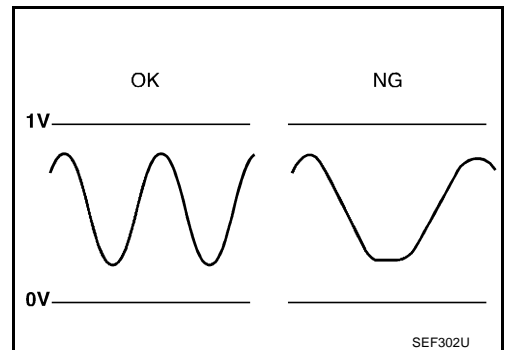

DTC No.	Trouble diagnosis name	DTC detecting condition	Possible cause
P0139 0139 (Bank 1)	Heated oxygen sensor 2 circuit slow response	It takes more time for the sensor to respond between rich and lean than the specified time.	<ul style="list-style-type: none"> ● Harness or connectors (The sensor circuit is open or shorted) ● Heated oxygen sensor 2 ● Fuel pressure ● Fuel injector ● Intake air leaks
P0159 0159 (Bank 2)			

DTC Confirmation Procedure

NOTE:

If DTC Confirmation Procedure has been previously conducted, always turn ignition switch OFF and wait at least 10 seconds before conducting the next test.

WITH CONSULT-II

TESTING CONDITION:

For better results, perform "DTC WORK SUPPORT" at a temperature of 0 to 30 °C (32 to 86 °F).

1. Turn ignition switch ON and select "DATA MONITOR" mode with CONSULT-II.
2. Start engine and warm it up to the normal operating temperature.
3. Turn ignition switch OFF and wait at least 10 seconds.
4. Start engine and keep the engine speed between 3,500 and 4,000 rpm for at least 1 minute under no load.
5. Let engine idle for 1 minute.
6. Make sure that "COOLAN TEMP/S" indicates more than 70°C (158°F).
If not, warm up engine and go to next step when "COOLAN TEMP/S" indication reaches to 70°C (158°F).
7. Select "HO2S2 (B1) P0139" or "HO2S2 (B2) P0159" of "HO2S2" in "DTC WORK SUPPORT" mode with CONSULT-II.
8. Start engine and following the instruction of CONSULT-II.

DATA MONITOR	
MONITOR	NO DTC
ENG SPEED	XXX rpm
COOLAN TEMP/S	XXX °C

SEF174Y

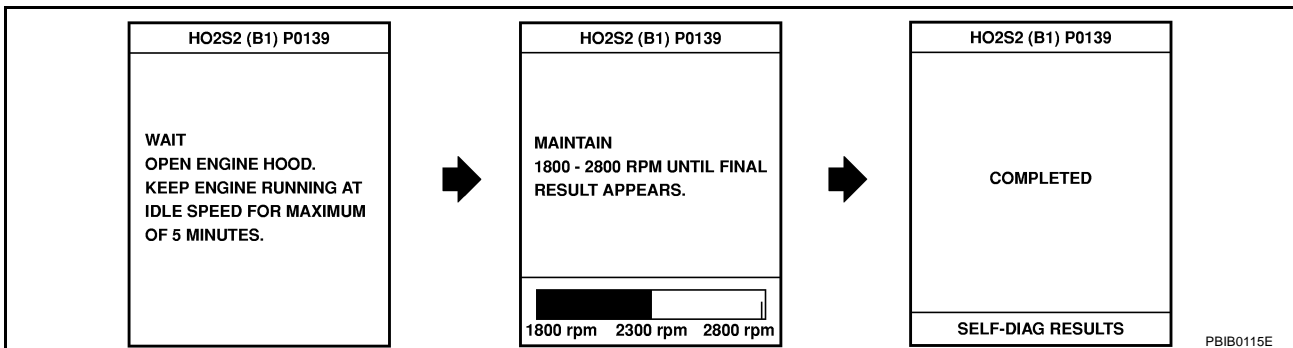

9. Make sure that "OK" is displayed after touching "SELF-DIAG RESULTS".
If "NG" is displayed, refer to [EC-251, "Diagnostic Procedure"](#).
If "CAN NOT BE DIAGNOSED" is displayed, perform the following.
 - a. Turn ignition switch OFF and leave the vehicle in a cool place (soak the vehicle).
 - b. Return to step 1.

Overall Function Check

Use this procedure to check the overall function of the heated oxygen sensor 2 circuit. During this check, a 1st trip DTC might not be confirmed.

WITH GST

1. Start engine and warm it up to the normal operating temperature.
2. Turn ignition switch OFF and wait at least 10 seconds.
3. Start engine and keep the engine speed between 3,500 and 4,000 rpm for at least 1 minute under no load.
4. Let engine idle for 1 minute.
5. Set voltmeter probes between ECM terminal 74 [HO2S2 (B1) signal] or 55 [HO2S2 (B2) signal] and ground.

DTC P0139, P0159 HO2S2

[VQ35DE]

6. Check the voltage when revving up to 4,000 rpm under no load at least 10 times.
(Depress and release accelerator pedal as soon as possible.)
A change of voltage should be more than 0.06V for 1 second during this procedure.
If the voltage can be confirmed in step 6, step 7 is not necessary.
7. Keep vehicle at idling for 10 minutes, then check the voltage. Or check the voltage when coasting from 80 km/h (50 MPH) in D position with "OD" OFF.
A change of voltage should be more than 0.06V for 1 second during this procedure.
8. If NG, go to [EC-251, "Diagnostic Procedure"](#).

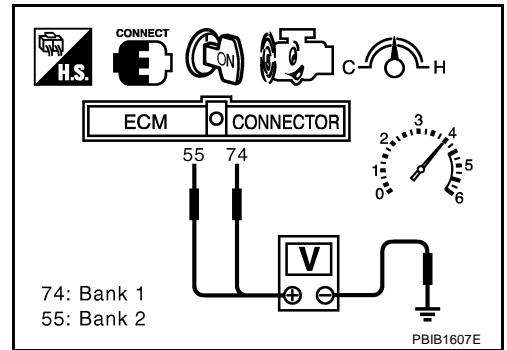

A
EC
C
D
E
F
G
H
I
J
K
L
M

Wiring Diagram
BANK 1

EC-O2S2B1-01

— : DETECTABLE LINE FOR DTC
 — : NON-DETECTABLE LINE FOR DTC

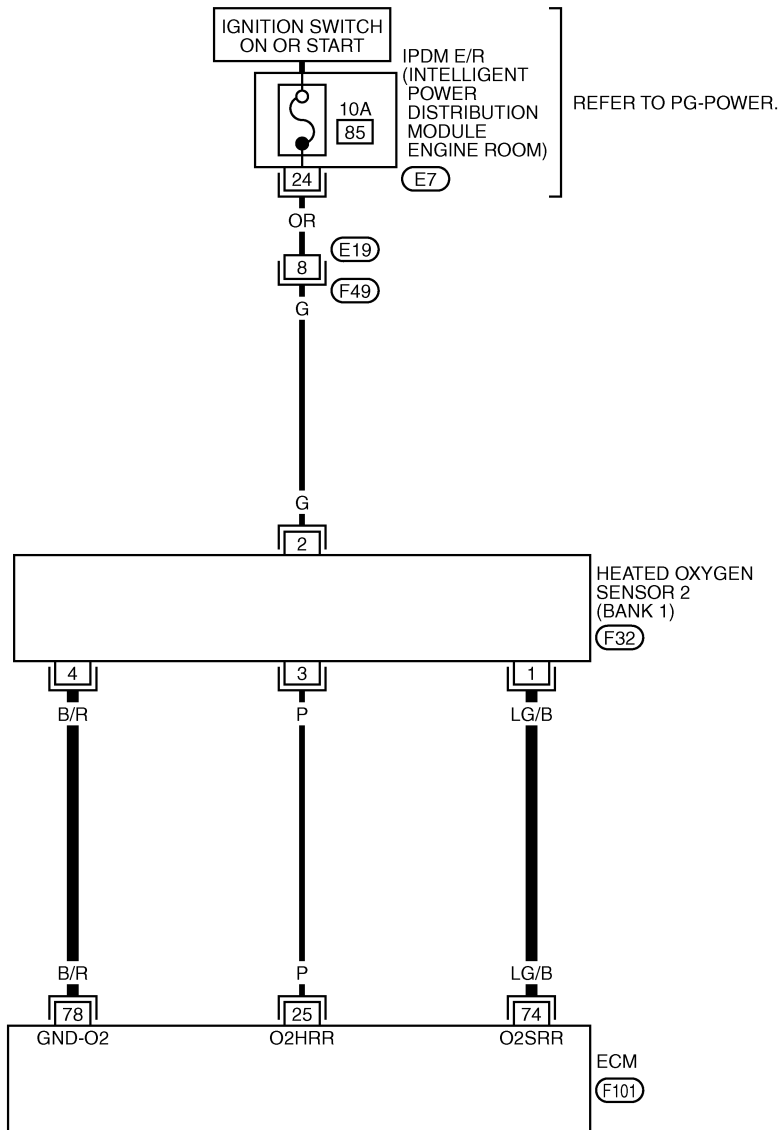

23	22	21	20	19	18	17		
32	31	30	29	28	27	26	25	24

(E7) GY



(F32) B



(F49) B

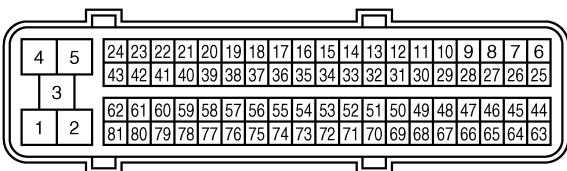

(F101) B



DTC P0139, P0159 HO2S2

[VQ35DE]

Specification data are reference values and are measured between each terminal and ground.

CAUTION:

Do not use ECM ground terminals when measuring input/output voltage. Doing so may result in damage to the ECM's transistor. Use a ground other than ECM terminals, such as the ground.

TER-MINAL NO.	WIRE COLOR	ITEM	CONDITION	DATA (DC Voltage)
74	LG/B	Heated oxygen sensor 2 (bank 1)	<p>[Engine is running]</p> <ul style="list-style-type: none"> ● Warm-up condition ● Revving engine from idle to 3,000 rpm quickly after the following conditions are met <ul style="list-style-type: none"> – After keeping the engine speed between 3,500 and 4,000 rpm for 1 minute and at idle for 1 minute under no load 	0 - Approximately 1.0V
78	B/R	Sensor ground (Heated oxygen sensor)	<p>[Engine is running]</p> <ul style="list-style-type: none"> ● Warm-up condition ● Idle speed 	Approximately 0V

A
EC
C
D
E
F
G
H
I
J
K
L
M

BANK 2

EC-O2S2B2-01

— : DETECTABLE LINE FOR DTC
 — : NON-DETECTABLE LINE FOR DTC

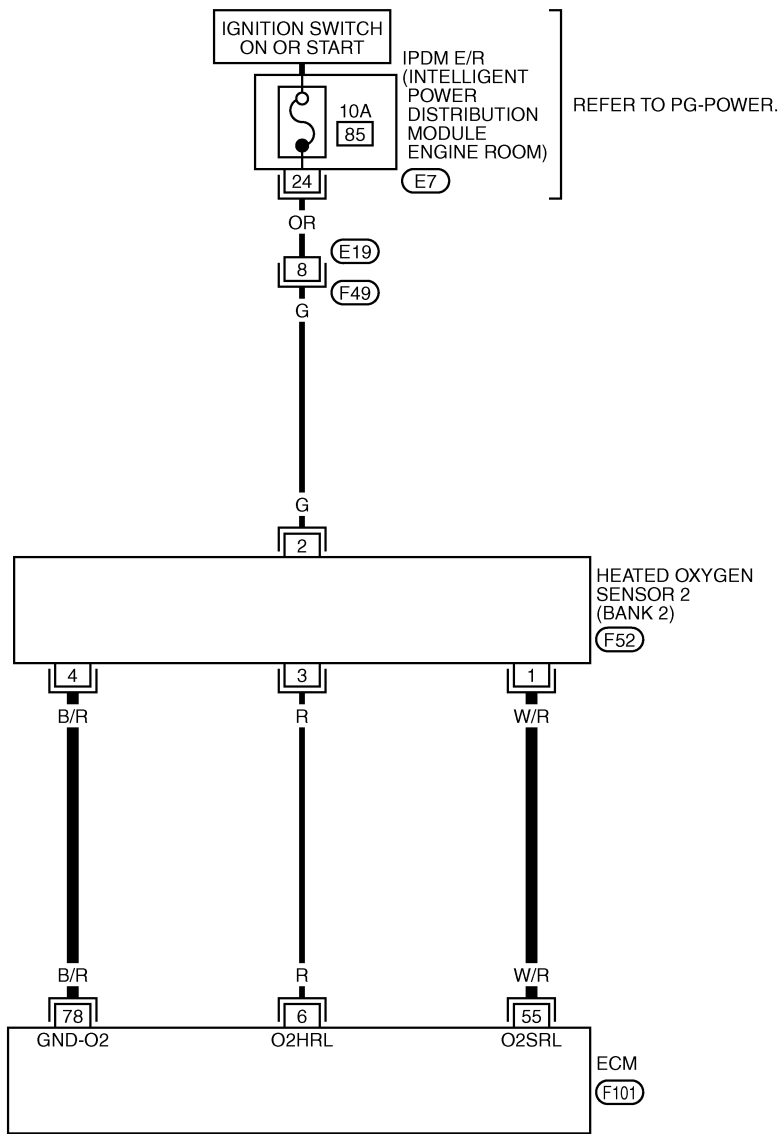

23	22	21	20	19	18	17		
32	31	30	29	28	27	26	25	24

E7 GY

1	2	3	4
5	6	7	8

F49 B

3	1
4	2

F52 GY

4	5	24	23	22	21	20	19	18	17	16	15	14	13	12	11	10	9	8	7	6
3		43	42	41	40	39	38	37	36	35	34	33	32	31	30	29	28	27	26	25
1	2	62	61	60	59	58	57	56	55	54	53	52	51	50	49	48	47	46	45	44
		81	80	79	78	77	76	75	74	73	72	71	70	69	68	67	66	65	64	63

F101 B

Specification data are reference values and are measured between each terminal and ground.

CAUTION:

Do not use ECM ground terminals when measuring input/output voltage. Doing so may result in damage to the ECM's transistor. Use a ground other than ECM terminals, such as the ground.

TER-MINAL NO.	WIRE COLOR	ITEM	CONDITION	DATA (DC Voltage)
55	W/R	Heated oxygen sensor 2 (bank 2)	<p>[Engine is running]</p> <ul style="list-style-type: none"> ● Warm-up condition ● Revving engine from idle to 3,000 rpm quickly after the following conditions are met – After keeping the engine speed between 3,500 and 4,000 rpm for 1 minute and at idle for 1 minute under no load 	0 - Approximately 1.0V
78	B/R	Sensor ground (Heated oxygen sensor)	<p>[Engine is running]</p> <ul style="list-style-type: none"> ● Warm-up condition ● Idle speed 	Approximately 0V

Diagnostic Procedure

ABS00CH3

1. CHECK GROUND CONNECTIONS

1. Turn ignition switch OFF.
2. Loosen and retighten ground three screws on the body. Refer to [EC-141, "Ground Inspection"](#).

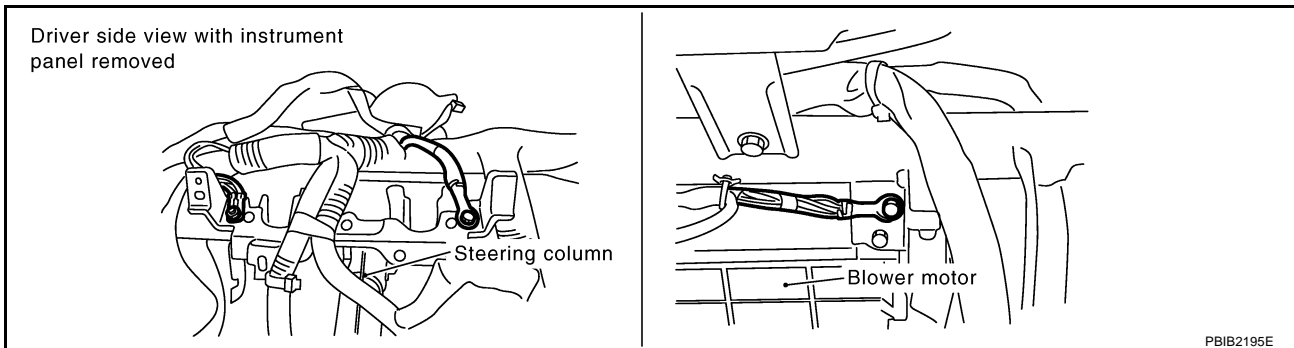

OK or NG

- OK >> GO TO 2.
- NG >> Repair or replace ground connections.

2. CLEAR THE SELF-LEARNING DATA

☑ With CONSULT-II

1. Start engine and warm it up to normal operating temperature.
2. Select "SELF-LEARNING CONT" in "WORK SUPPORT" mode with CONSULT-II.
3. Clear the self-learning control coefficient by touching "CLEAR".
4. Run engine for at least 10 minutes at idle speed.
**Is the 1st trip DTC P0171, P0172, P0174 or P0175 detected?
Is it difficult to start engine?**

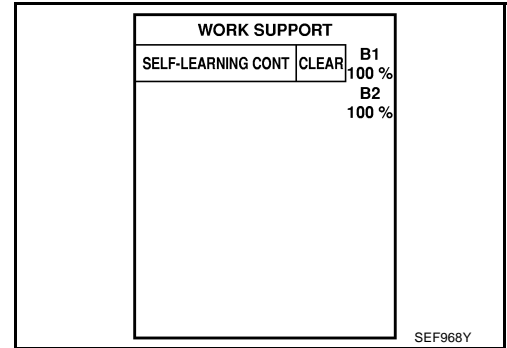

⊗ Without CONSULT-II

1. Start engine and warm it up to normal operating temperature.
2. Turn ignition switch OFF.
3. Disconnect mass air flow sensor harness connector, and restart and run engine for at least 5 seconds at idle speed.
4. Stop engine and reconnect mass air flow sensor harness connector.
5. Make sure DTC P0102 is displayed.
6. Erase the DTC memory. Refer to [EC-67, "HOW TO ERASE EMISSION-RELATED DIAGNOSTIC INFORMATION"](#).
7. Make sure DTC P0000 is displayed.
8. Run engine for at least 10 minutes at idle speed.
**Is the 1st trip DTC P0171, P0172, P0174 or P0175 detected?
Is it difficult to start engine?**

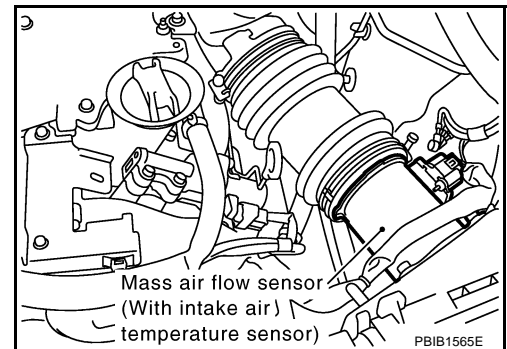

Yes or No

- Yes >> Perform trouble diagnosis for DTC P0171, P0174 or P0172, P0175. Refer to [EC-256](#) or [EC-265](#).
No >> GO TO 3.

3. CHECK HO2S2 GROUND CIRCUIT FOR OPEN AND SHORT

1. Turn ignition switch OFF.
2. Disconnect heated oxygen sensor 2 harness connector.
3. Disconnect ECM harness connector.
4. Check harness continuity between HO2S2 terminal 4 and ECM terminal 78.
Refer to Wiring Diagram.

Continuity should exist.

5. Also check harness for short to ground and short to power.

OK or NG

- OK >> GO TO 4.
NG >> Repair open circuit or short to ground or short to power in harness or connectors.

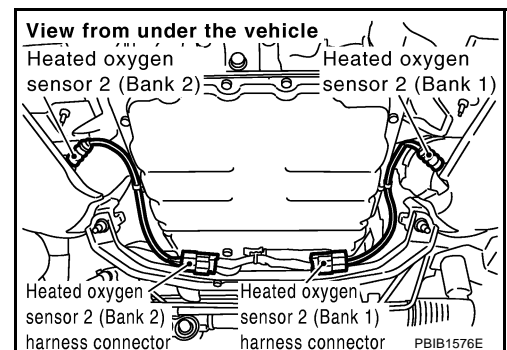

4. CHECK HO2S2 INPUT SIGNAL CIRCUIT FOR OPEN AND SHORT

1. Check harness continuity between ECM terminal and HO2S2 terminal as follows.
Refer to Wiring Diagram.

DTC	Terminals		Bank
	ECM	Sensor	
P0139	74	1	1
P0159	55	1	2

Continuity should exist.

2. Check harness continuity between the following terminals and ground.
Refer to Wiring Diagram.

DTC	Terminals		Bank
	ECM	Sensor	
P0139	74	1	1
P0159	55	1	2

Continuity should not exist.

3. Also check harness for short to power.

OK or NG

OK >> GO TO 5.

NG >> Repair open circuit or short to ground or short to power in harness or connectors.

5. CHECK HEATED OXYGEN SENSOR 2

Refer to [EC-253, "Component Inspection"](#) .

OK or NG

OK >> GO TO 6.

NG >> Replace malfunctioning heated oxygen sensor 2.

6. CHECK INTERMITTENT INCIDENT

Refer to [EC-135, "TROUBLE DIAGNOSIS FOR INTERMITTENT INCIDENT"](#) .

>> INSPECTION END

**Component Inspection
HEATED OXYGEN SENSOR 2**

ABS0060W

Ⓟ **With CONSULT-II**

1. Turn ignition switch ON and select "DATA MONITOR" mode with CONSULT-II.
2. Start engine and warm it up to the normal operating temperature.
3. Turn ignition switch OFF and wait at least 10 seconds.
4. Start engine and keep the engine speed between 3,500 and 4,000 rpm for at least 1 minute under no load.
5. Let engine idle for 1 minute.

DATA MONITOR	
MONITOR	NO DTC
ENG SPEED	XXX rpm
COOLAN TEMP/S	XXX °C

SEF174Y

- Select "FUEL INJECTION" in "ACTIVE TEST" mode, and select "HO2S2 (B1)/(B2)" as the monitor item with CONSULT-II.

ACTIVE TEST	
FUEL INJECTION	25 %
MONITOR	
ENG SPEED	XXX rpm
HO2S1 (B1)	XXX V
HO2S2 (B1)	XXX V
HO2S1 MNTR (B1)	RICH
HO2S2 MNTR (B1)	RICH

SEF662Y

- Check "HO2S2 (B1)/(B2)" at idle speed when adjusting "FUEL INJECTION" to $\pm 25\%$.

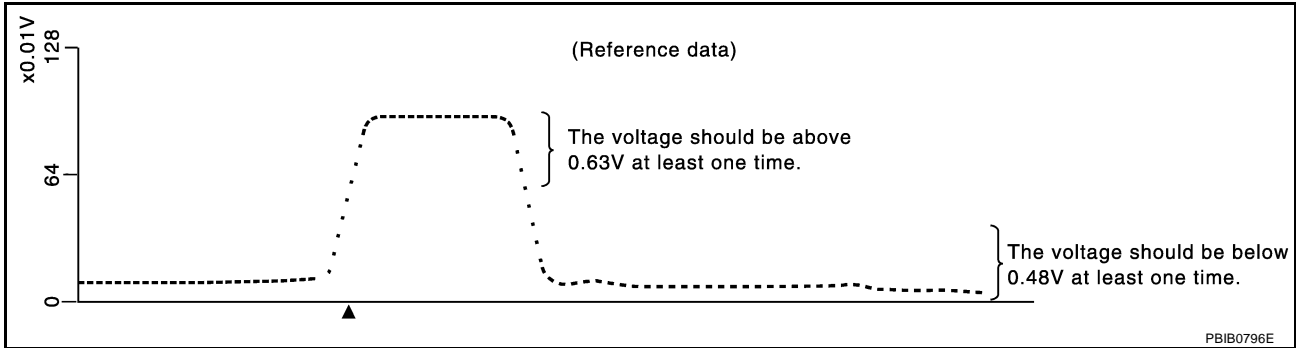

"HO2S2 (B1)/(B2)" should be above 0.63V at least once when the "FUEL INJECTION" is +25%.
 "HO2S2 (B1)/(B2)" should be below 0.48V at least once when the "FUEL INJECTION" is -25%.

CAUTION:

- Discard any heated oxygen sensor which has been dropped from a height of more than 0.5 m (19.7 in) onto a hard surface such as a concrete floor; use a new one.
- Before installing new oxygen sensor, clean exhaust system threads using Oxygen Sensor Thread Cleaner tool J-43897-18 or J-43897-12 and approved anti-seize lubricant.

Without CONSULT-II

- Start engine and warm it up to the normal operating temperature.
- Turn ignition switch OFF and wait at least 10 seconds.
- Start engine and keep the engine speed between 3,500 and 4,000 rpm for at least 1 minute under no load.
- Let engine idle for 1 minute.
- Set voltmeter probes between ECM terminal 74 [HO2S2 (B1) signal] or 55 [HO2S2 (B2) signal] and ground.
- Check the voltage when revving up to 4,000 rpm under no load at least 10 times.
 (Depress and release accelerator pedal as soon as possible.)
The voltage should be above 0.63V at least once during this procedure.
If the voltage is above 0.63V at step 6, step 7 is not necessary.
- Keep vehicle at idling for 10 minutes, then check voltage. Or check the voltage when coasting from 80 km/h (50 MPH) in D position with "OD" OFF.
The voltage should be below 0.48V at least once during this procedure.
- If NG, replace heated oxygen sensor 2.

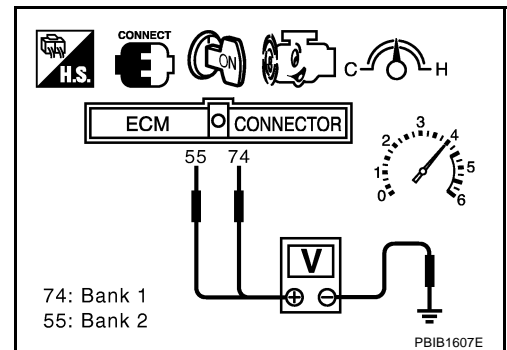

CAUTION:

- Discard any heated oxygen sensor which has been dropped from a height of more than 0.5 m (19.7 in) onto a hard surface such as a concrete floor; use a new one.
- Before installing new oxygen sensor, clean exhaust system threads using Oxygen Sensor Thread Cleaner tool J-43897-18 or J-43897-12 and approved anti-seize lubricant.

Removal and Installation
HEATED OXYGEN SENSOR 2

Refer to [EM-26, "EXHAUST MANIFOLD AND THREE WAY CATALYST"](#) .

A

EC

C

D

E

F

G

H

I

J

K

L

M

DTC P0171, P0174 FUEL INJECTION SYSTEM FUNCTION

PFP:16600

On Board Diagnosis Logic

ABS0060Y

With the Air-Fuel Mixture Ratio Self-Learning Control, the actual mixture ratio can be brought closely to the theoretical mixture ratio based on the mixture ratio feedback signal from the heated oxygen sensors 1. The ECM calculates the necessary compensation to correct the offset between the actual and the theoretical ratios.

In case the amount of the compensation value is extremely large (the actual mixture ratio is too lean.), the ECM judges the condition as the fuel injection system malfunction and lights up the MIL (2 trip detection logic).

Sensor	Input signal to ECM	ECM function	Actuator
Heated oxygen sensor 1	Density of oxygen in exhaust gas (Mixture ratio feedback signal)	Fuel injection control	Fuel injector

DTC No.	Trouble diagnosis name	DTC detecting condition	Possible cause
P0171 0171 (Bank 1)	Fuel injection system too lean	<ul style="list-style-type: none"> ● Fuel injection system does not operate properly. ● The amount of mixture ratio compensation is too large. (The mixture ratio is too lean.) 	<ul style="list-style-type: none"> ● Intake air leaks ● Heated oxygen sensor 1 ● Fuel Injector ● Exhaust gas leaks ● Incorrect fuel pressure ● Lack of fuel ● Mass air flow sensor ● Incorrect PCV hose connection
P0174 0174 (Bank 2)			

DTC Confirmation Procedure

ABS0060Z

NOTE:

If DTC Confirmation Procedure has been previously conducted, always turn ignition switch OFF and wait at least 10 seconds before conducting the next test.

WITH CONSULT-II

1. Start engine and warm it up to normal operating temperature.
2. Turn ignition switch OFF and wait at least 10 seconds.
3. Turn ignition switch ON and select "SELF-LEARNING CONT" in "WORK SUPPORT" mode with CONSULT-II.
4. Clear the self-learning control coefficient by touching "CLEAR".
5. Select "DATA MONITOR" mode with CONSULT-II.
6. Start engine again and let it idle for at least 10 minutes. The 1st trip DTC P0171 or P0174 should be detected at this stage, if a malfunction exists. If so, go to Diagnostic Procedure, [EC-260](#).
7. If it is difficult to start engine at step 6, the fuel injection system has a malfunction, too.
8. Crank engine while depressing accelerator pedal. If engine starts, go to [EC-260, "Diagnostic Procedure"](#). If engine does not start, check exhaust and intake air leak visually.

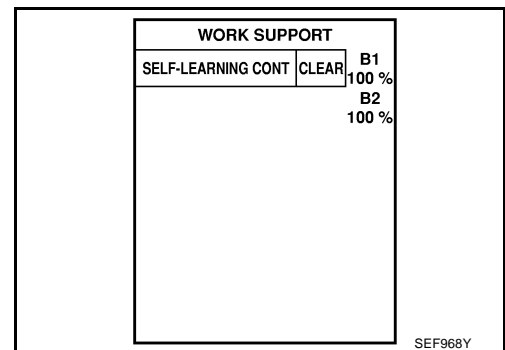

WITH GST

1. Start engine and warm it up to normal operating temperature.
2. Turn ignition switch OFF and wait at least 10 seconds.
3. Disconnect mass air flow sensor harness connector. Then restart and run engine for at least 5 seconds at idle speed.
4. Stop engine and reconnect mass air flow sensor harness connector.
5. Select MODE 3 with GST. Make sure DTC P0102 is detected.
6. Select MODE 4 with GST and erase the DTC P0102.
7. Start engine again and let it idle for at least 10 minutes.
8. Select MODE 7 with GST. The 1st trip DTC P0171 or P0174 should be detected at this stage, if a malfunction exists. If so, go to [EC-260, "Diagnostic Procedure"](#).
9. If it is difficult to start engine at step 7, the fuel injection system has a malfunction.
10. Crank engine while depressing accelerator pedal. If engine starts, go to Diagnostic Procedure, [EC-260](#). If engine does not start, check exhaust and intake air leak visually.

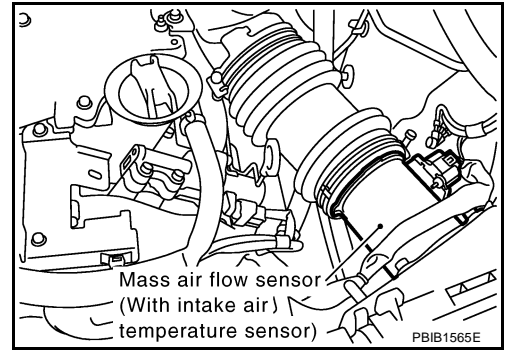

A
EC
C
D
E
F
G
H
I
J
K
L
M

DTC P0171, P0174 FUEL INJECTION SYSTEM FUNCTION

[VQ35DE]

ABS006P0

Wiring Diagram BANK 1

EC-FUELB1-01

— : DETECTABLE LINE FOR DTC
- - - : NON-DETECTABLE LINE FOR DTC

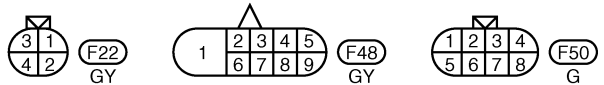
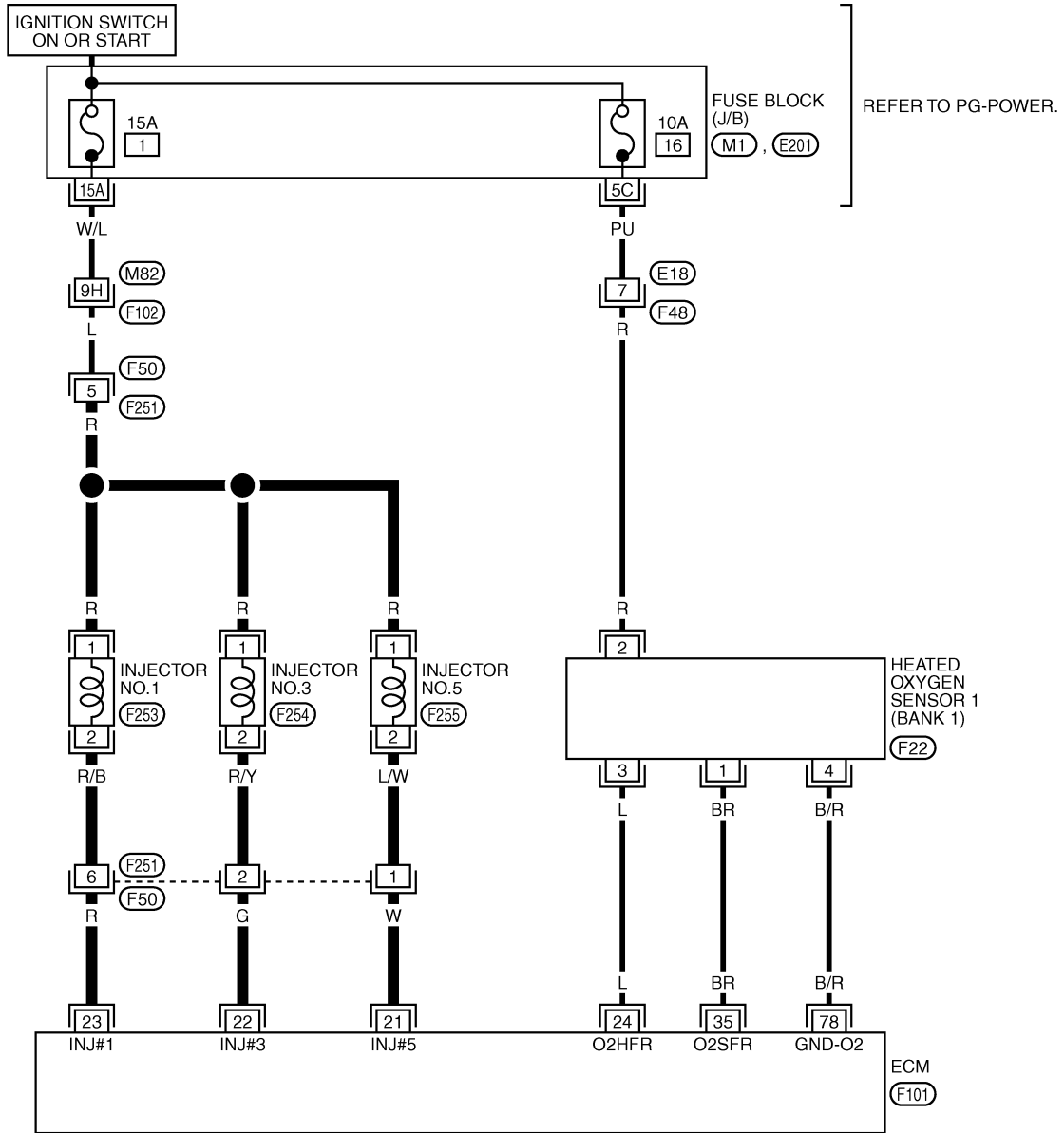

REFER TO THE FOLLOWING.
 (F102) -SUPER MULTIPLE JUNCTION (SMJ)
 (M1), (E201) -FUSE BLOCK-JUNCTION BOX (J/B)

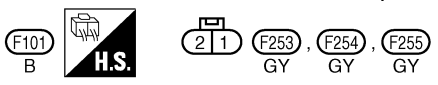
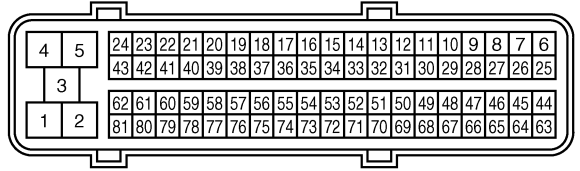

TBWM0294E

DTC P0171, P0174 FUEL INJECTION SYSTEM FUNCTION

[VQ35DE]

BANK 2

EC-FUELB2-01

: DETECTABLE LINE FOR DTC
 : NON-DETECTABLE LINE FOR DTC

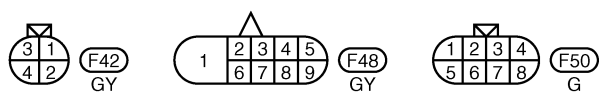
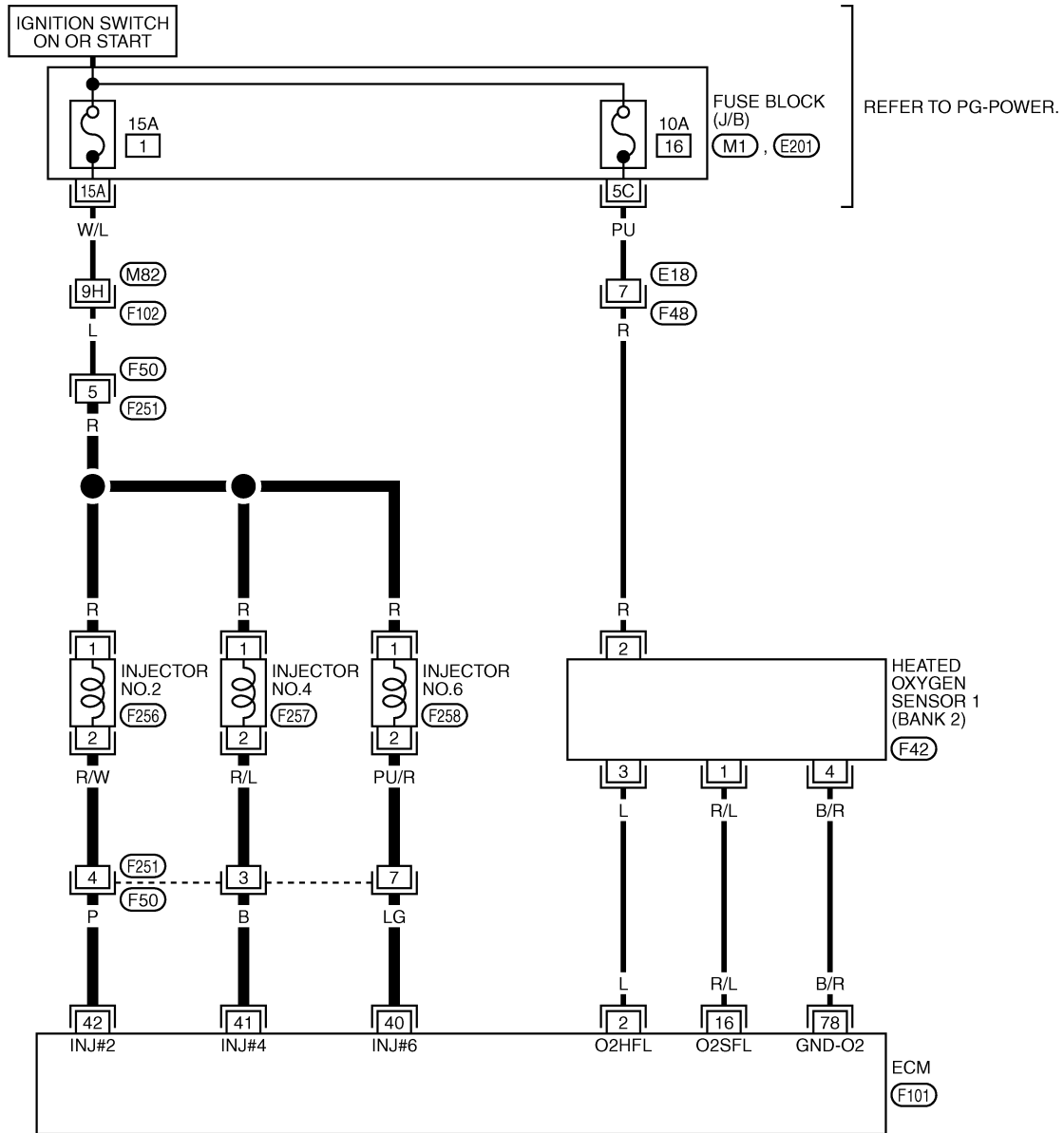

REFER TO THE FOLLOWING.
 (F102) -SUPER MULTIPLE JUNCTION (SMJ)
 (M1), (E201) -FUSE BLOCK-JUNCTION BOX (J/B)

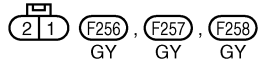
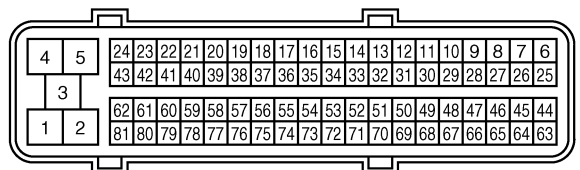

TBWM0295E

Diagnostic Procedure

1. CHECK EXHAUST GAS LEAK

1. Start engine and run it at idle.
2. Listen for an exhaust gas leak before three way catalyst 1.

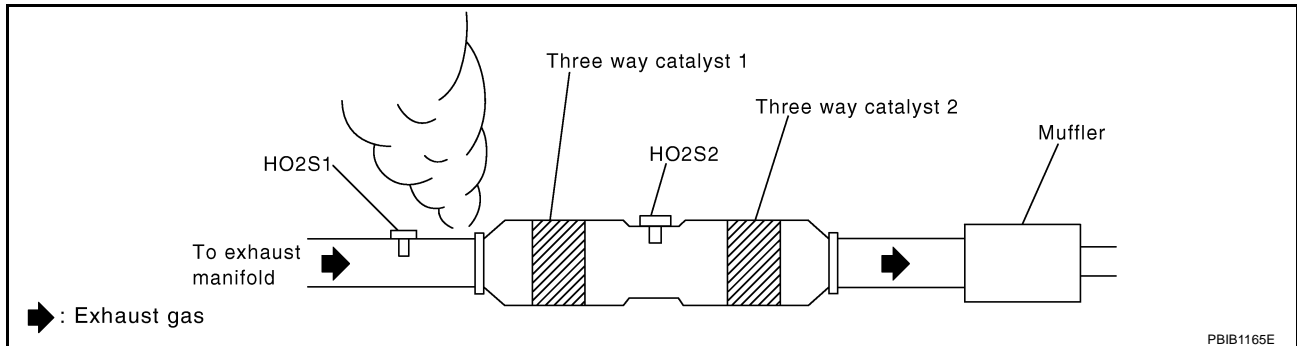

OK or NG

- OK >> GO TO 2.
- NG >> Repair or replace.

2. CHECK FOR INTAKE AIR LEAK

1. Listen for an intake air leak after the mass air flow sensor.
2. Check PCV hose connection.

OK or NG

- OK >> GO TO 3.
- NG >> Repair or replace.

3. CHECK HEATED OXYGEN SENSOR 1 CIRCUIT FOR OPEN AND SHORT

1. Turn ignition switch OFF.
2. Disconnect corresponding heated oxygen sensor 1 (HO2S1) harness connector.

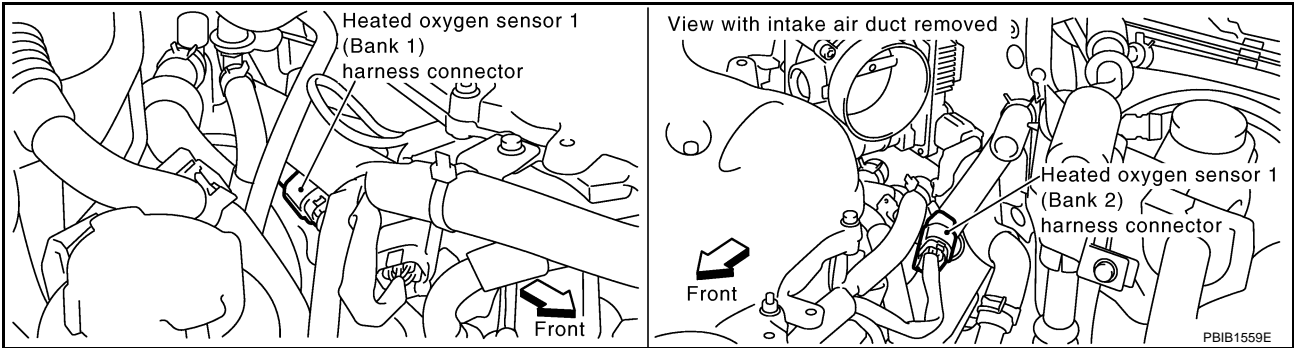

3. Disconnect ECM harness connector.
4. Check harness continuity between ECM terminal and HO2S1 terminal as follows. Refer to Wiring Diagram.

DTC	Terminals		Bank
	ECM	Sensor	
P0171	35	1	1
P0174	16	1	2

Continuity should exist.

5. Check harness continuity between the following terminals and ground. Refer to Wiring Diagram.

DTC	Terminals		Bank
	ECM	Sensor	
P0171	35	1	1
P0174	16	1	2

Continuity should not exist.

6. Check harness continuity between HO2S1 terminal 4 and ground.

Continuity should exist.

7. Also check harness for short to ground and short to power.

OK or NG

OK >> GO TO 4.

NG >> Repair open circuit or short to ground or short to power in harness or connectors.

4. CHECK FUEL PRESSURE

1. Release fuel pressure to zero. Refer to [EC-51, "FUEL PRESSURE RELEASE"](#) .
2. Install fuel pressure gauge and check fuel pressure. Refer to [EC-52, "FUEL PRESSURE CHECK"](#) .

At idling: 350 kPa (3.57 kg/cm² , 51 psi)

OK or NG

OK >> GO TO 6.

NG >> GO TO 5.

5. DETECT MALFUNCTIONING PART

Check the following.

- Fuel pump and circuit (Refer to [EC-603](#) .)
- Fuel pressure regulator (Refer to [EC-51](#) .)
- Fuel lines
- Fuel filter for clogging

>> Repair or replace.

6. CHECK MASS AIR FLOW SENSOR

With CONSULT-II

1. Install all removed parts.
2. Check "MASS AIR FLOW" in "DATA MONITOR" mode with CONSULT-II.

2.0 - 6.0 g-m/sec: at idling

7.0 - 20.0 g-m/sec: at 2,500 rpm

With GST

1. Install all removed parts.
2. Check mass air flow sensor signal in MODE 1 with GST.

2.0 - 6.0 g-m/sec: at idling

7.0 - 20.0 g-m/sec: at 2,500 rpm

OK or NG

OK >> GO TO 7.

NG >> Check connectors for rusted terminals or loose connections in the mass air flow sensor circuit or ground. Refer to [EC-165, "DTC P0101 MAF SENSOR"](#) .

7. CHECK FUNCTION OF INJECTORS

With CONSULT-II

1. Start engine.
2. Perform "POWER BALANCE" in "ACTIVE TEST" mode with CONSULT-II.
3. Make sure that each circuit produces a momentary engine speed drop.

ACTIVE TEST	
POWER BALANCE	
MONITOR	
ENG SPEED	XXX rpm
MAS A/F SE-B1	XXX V

PBIB0133E

Without CONSULT-II

1. Start engine.
2. Listen to each injector operating sound.

Clicking noise should be heard.

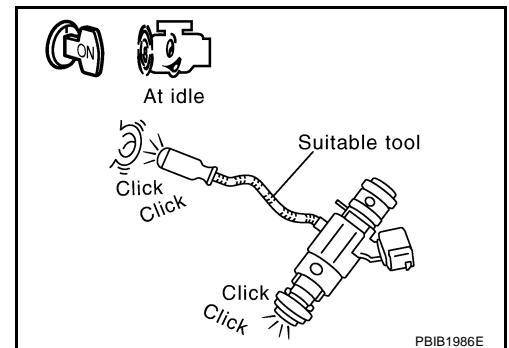

OK or NG

- OK >> GO TO 8.
- NG >> Perform trouble diagnosis for INJECTORS, [EC-597](#) .

8. CHECK INJECTOR

1. Confirm that the engine is cooled down and there are no fire hazards near the vehicle.
2. Turn ignition switch OFF.
3. Disconnect all injector harness connectors.
4. Remove injector gallery assembly. Refer to [EM-45, "FUEL INJECTOR AND FUEL TUBE"](#) . Keep fuel hose and all injectors connected to injector gallery.
5. For DTC P0171, reconnect injector harness connectors on bank 1.
For DTC P0174, reconnect injector harness connectors on bank 2.
6. Disconnect all ignition coil harness connectors.
7. Prepare pans or saucers under each injector.
8. Crank engine for about 3 seconds.
For DTC P0171, make sure that fuel sprays out from injectors on bank 1.
For DTC P0174, make sure that fuel sprays out from injectors on bank 2.

Fuel should be sprayed evenly for each injector.

OK or NG

- OK >> GO TO 9.
- NG >> Replace injectors from which fuel does not spray out.
Always replace O-ring with new ones.

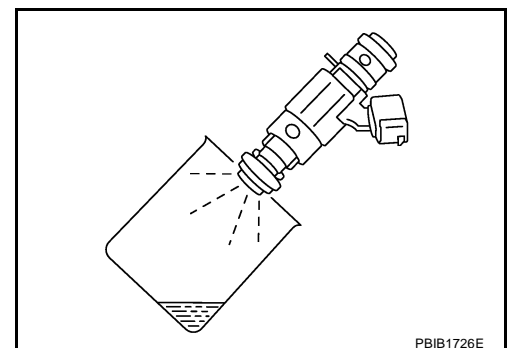

9. CHECK INTERMITTENT INCIDENT

Refer to [EC-135, "TROUBLE DIAGNOSIS FOR INTERMITTENT INCIDENT"](#) .

>> INSPECTION END

DTC P0172, P0175 FUEL INJECTION SYSTEM FUNCTION

PFP:16600

On Board Diagnosis Logic

ABS006P2

With the Air-Fuel Mixture Ratio Self-Learning Control, the actual mixture ratio can be brought closely to the theoretical mixture ratio based on the mixture ratio feedback signal from the heated oxygen sensors 1. The ECM calculates the necessary compensation to correct the offset between the actual and the theoretical ratios.

In case the amount of the compensation value is extremely large (the actual mixture ratio is too rich.), the ECM judges the condition as the fuel injection system malfunction and lights up the MIL (2 trip detection logic).

Sensor	Input signal to ECM	ECM function	Actuator
Heated oxygen sensor 1	Density of oxygen in exhaust gas (Mixture ratio feedback signal)	Fuel injection control	Fuel injector

DTC No.	Trouble diagnosis name	DTC detecting condition	Possible cause
P0172 0172 (Bank 1)	Fuel injection system too rich	<ul style="list-style-type: none"> ● Fuel injection system does not operate properly. ● The amount of mixture ratio compensation is too large. (The mixture ratio is too rich.) 	<ul style="list-style-type: none"> ● Heated oxygen sensor 1 ● Fuel injector ● Exhaust gas leaks ● Incorrect fuel pressure ● Mass air flow sensor
P0175 0175 (Bank 2)			

DTC Confirmation Procedure

ABS006P3

NOTE:

If DTC Confirmation Procedure has been previously conducted, always turn ignition switch OFF and wait at least 10 seconds before conducting the next test.

WITH CONSULT-II

1. Start engine and warm it up to normal operating temperature.
2. Turn ignition switch OFF and wait at least 10 seconds.
3. Turn ignition switch ON and select "SELF-LEARNING CONT" in "WORK SUPPORT" mode with CONSULT-II.
4. Clear the self-learning control coefficient by touching "CLEAR".
5. Select "DATA MONITOR" mode with CONSULT-II.
6. Start engine again and let it idle for at least 10 minutes.
The 1st trip DTC P0172, P0175 should be detected at this stage, if a malfunction exists. If so, go to [EC-269, "Diagnostic Procedure"](#).
7. If it is difficult to start engine at step 6, the fuel injection system has a malfunction, too.
8. Crank engine while depressing accelerator pedal.
If engine starts, go to [EC-269, "Diagnostic Procedure"](#). If engine does not start, remove spark plugs and check for fouling, etc.

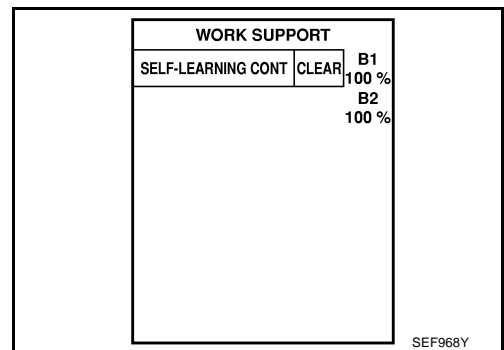

 **WITH GST**

1. Start engine and warm it up to normal operating temperature.
2. Turn ignition switch OFF and wait at least 10 seconds.
3. Disconnect mass air flow sensor harness connector. Then restart and run engine for at least 5 seconds at idle speed.
4. Stop engine and reconnect mass air flow sensor harness connector.
5. Select MODE 3 with GST. Make sure DTC P0102 is detected.
6. Select MODE 4 with GST and erase the DTC P0102.
7. Start engine again and let it idle for at least 10 minutes.
8. Select MODE 7 with GST. The 1st trip DTC P0172 or P0175 should be detected at this stage, if a malfunction exists. If so, go to [EC-269, "Diagnostic Procedure"](#) .
9. If it is difficult to start engine at step 7, the fuel injection system has a malfunction.
10. Crank engine while depressing accelerator pedal.
If engine starts, go to [EC-269, "Diagnostic Procedure"](#) . If engine does not start, remove spark plugs and check for fouling, etc.

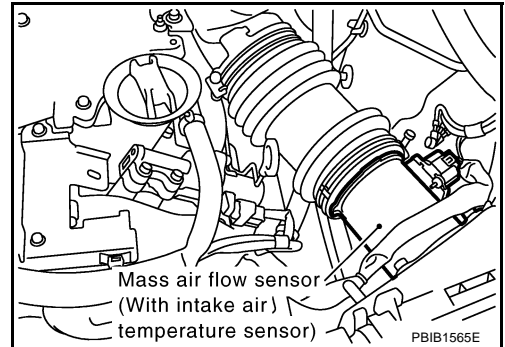

DTC P0172, P0175 FUEL INJECTION SYSTEM FUNCTION

[VQ35DE]

ABS006P4

Wiring Diagram BANK 1

EC-FUELB1-01

— : DETECTABLE LINE FOR DTC
- - - : NON-DETECTABLE LINE FOR DTC

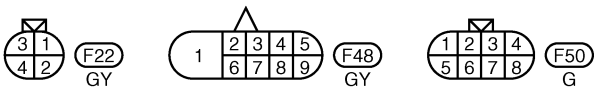
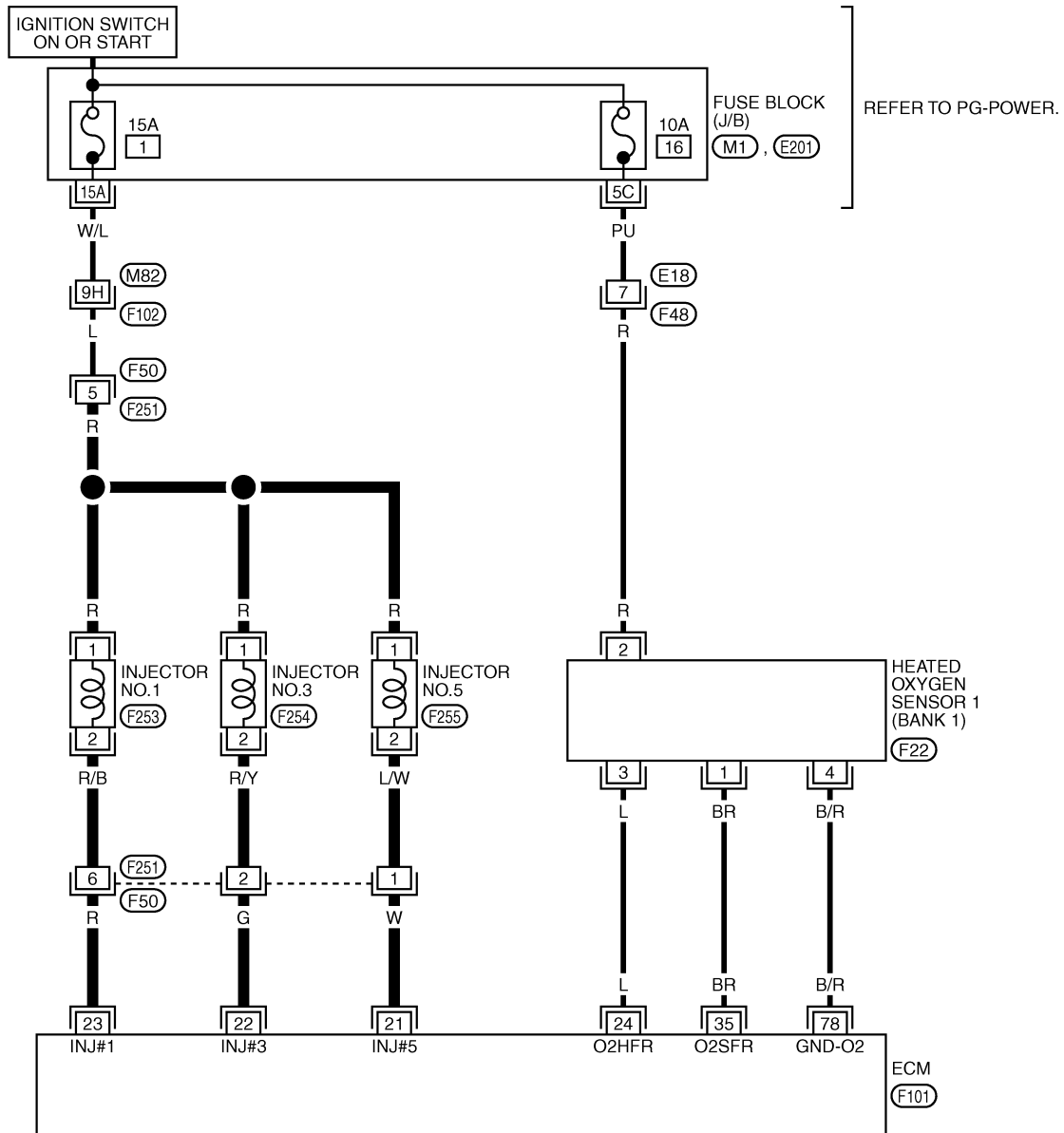

REFER TO THE FOLLOWING.
 (F102) -SUPER MULTIPLE JUNCTION (SMJ)
 (M1), (E201) -FUSE BLOCK-JUNCTION BOX (J/B)

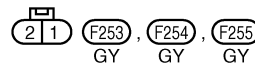
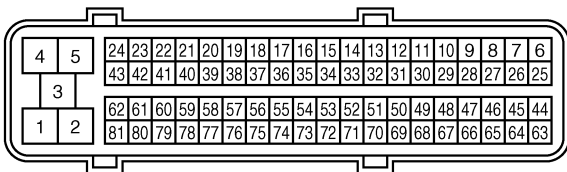

TBWM0294E

DTC P0172, P0175 FUEL INJECTION SYSTEM FUNCTION

[VQ35DE]

BANK 2

EC-FUELB2-01

— : DETECTABLE LINE FOR DTC
 - - - : NON-DETECTABLE LINE FOR DTC

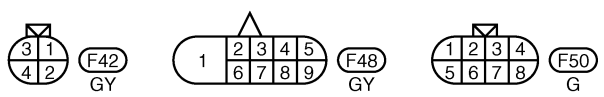
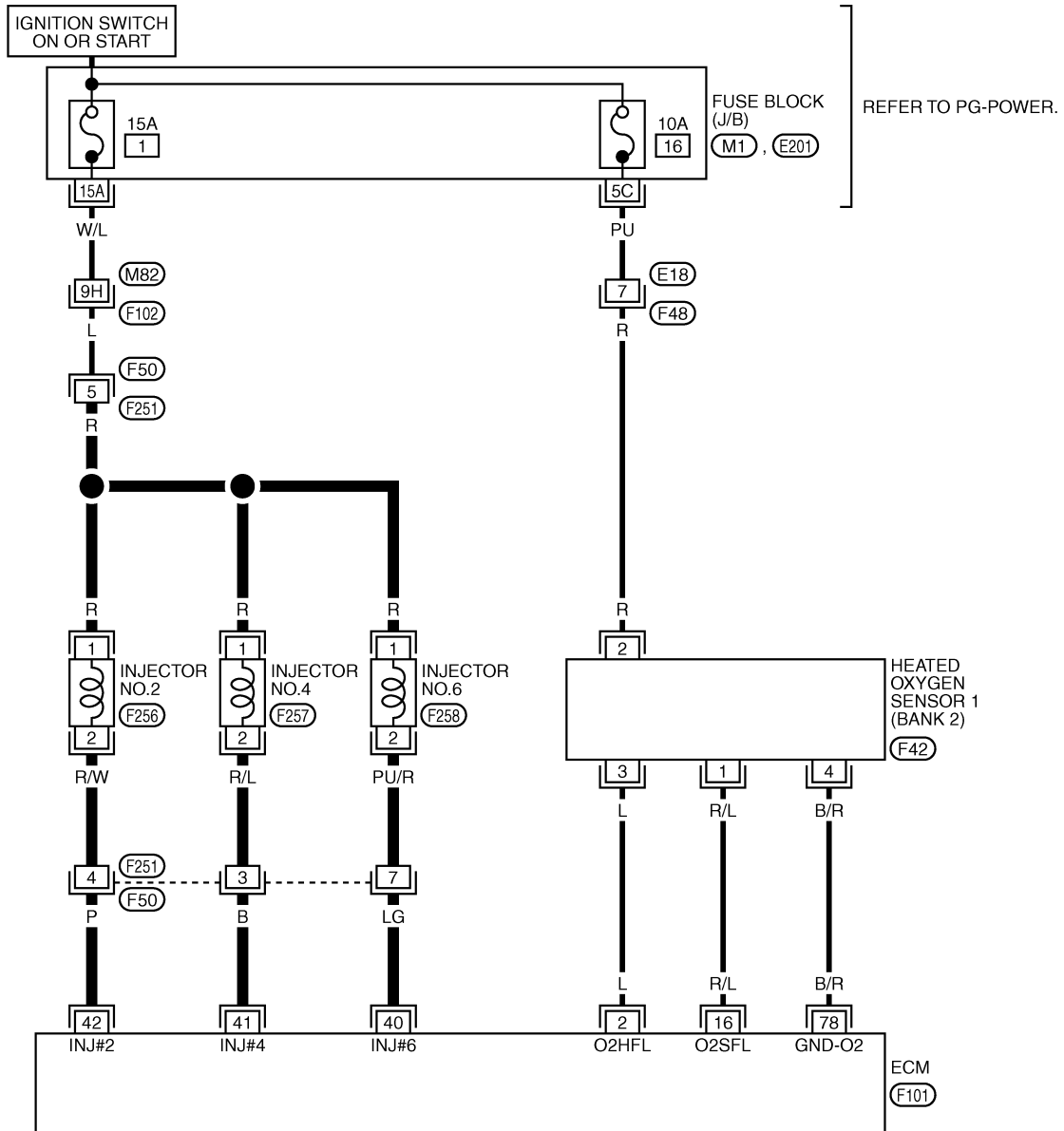

REFER TO THE FOLLOWING.
 (F102) -SUPER MULTIPLE JUNCTION (SMJ)
 (M1), (E201) -FUSE BLOCK-JUNCTION BOX (J/B)

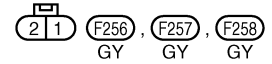
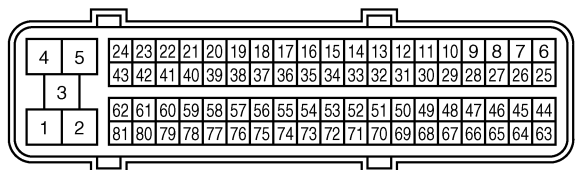

TBWM0295E

Diagnostic Procedure

1. CHECK EXHAUST GAS LEAK

1. Start engine and run it at idle.
2. Listen for an exhaust gas leak before three way catalyst 1.

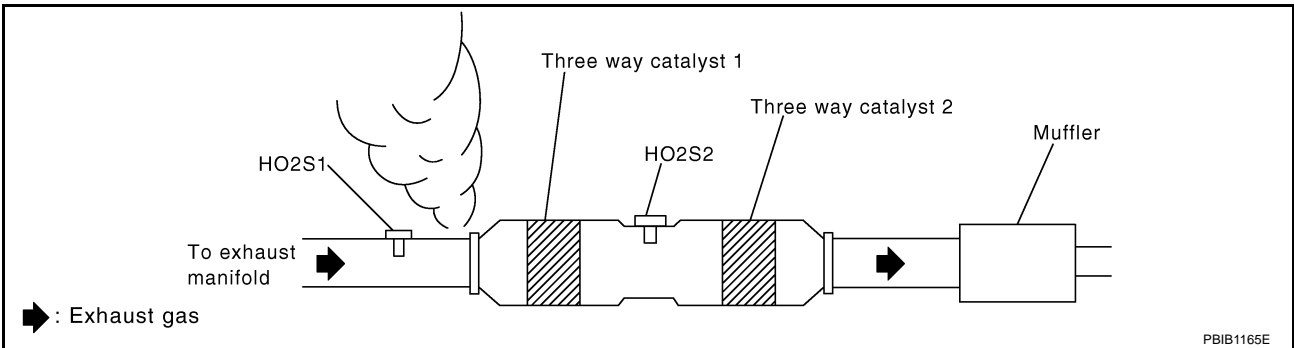

OK or NG

- OK >> GO TO 2.
- NG >> Repair or replace.

2. CHECK FOR INTAKE AIR LEAK

Listen for an intake air leak after the mass air flow sensor.

OK or NG

- OK >> GO TO 3.
- NG >> Repair or replace.

A
EC
C
D
E
F
G
H
I
J
K
L
M

3. CHECK HEATED OXYGEN SENSOR 1 CIRCUIT FOR OPEN AND SHORT

1. Turn ignition switch OFF.
2. Disconnect corresponding heated oxygen sensor 1 (HO2S1) harness connector.

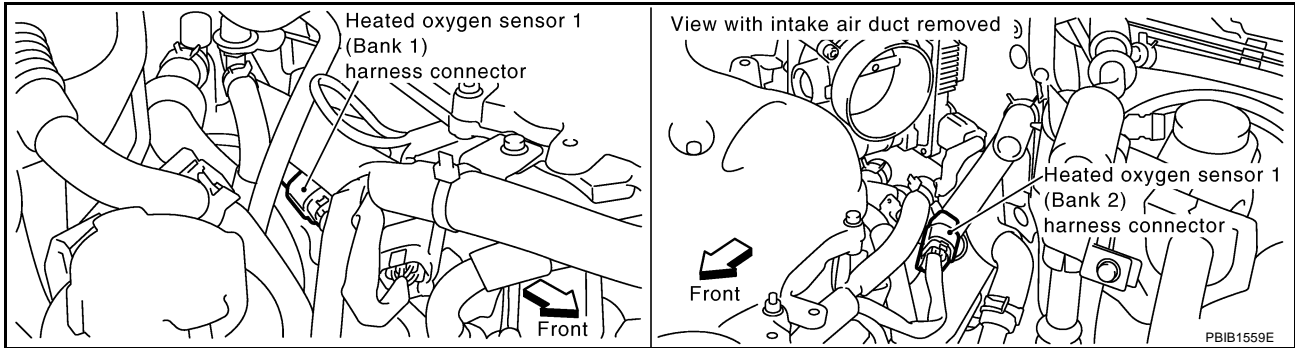

3. Disconnect ECM harness connector.
4. Check harness continuity between ECM terminal and HO2S1 terminal as follows. Refer to Wiring Diagram.

DTC	Terminals		Bank
	ECM	Sensor	
P0172	35	1	1
P0175	16	1	2

Continuity should exist.

5. Check harness continuity between the following terminals and ground. Refer to Wiring Diagram.

DTC	Terminals		Bank
	ECM	Sensor	
P0172	35	1	1
P0175	16	1	2

Continuity should not exist.

6. Check harness continuity between HO2S1 terminal 4 and ground.

Continuity should exist.

7. Also check harness for short to ground to short to power.

OK or NG

OK >> GO TO 4.

NG >> Repair open circuit or short to ground or short to power in harness or connectors.

4. CHECK FUEL PRESSURE

1. Release fuel pressure to zero. Refer to [EC-51, "FUEL PRESSURE RELEASE"](#) .
2. Install fuel pressure gauge and check fuel pressure. Refer to [EC-52, "FUEL PRESSURE CHECK"](#) .

At idling: 350 kPa (3.57 kg/cm² , 51 psi)

OK or NG

OK >> GO TO 6.

NG >> GO TO 5.

5. DETECT MALFUNCTIONING PART

Check the following.

- Fuel pump and circuit (Refer to, [EC-603](#) .)
- Fuel pressure regulator (Refer to [EC-51](#) .)

>> Repair or replace.

6. CHECK MASS AIR FLOW SENSOR**🔧 With CONSULT-II**

1. Install all removed parts.
2. Check "MASS AIR FLOW" in "DATA MONITOR" mode with CONSULT-II.

2.0 - 6.0 g-m/sec: at idling

7.0 - 20.0 g-m/sec: at 2,500 rpm

🔧 With GST

1. Install all removed parts.
2. Check mass air flow sensor signal in MODE 1 with GST.

2.0 - 6.0 g-m/sec: at idling

7.0 - 20.0 g-m/sec: at 2,500 rpm

OK or NG

OK >> GO TO 7.

NG >> Check connectors for rusted terminals or loose connections in the mass air flow sensor circuit or ground. Refer to [EC-165, "DTC P0101 MAF SENSOR"](#) .

A

EC

C

D

E

F

G

H

I

J

K

L

M

7. CHECK FUNCTION OF INJECTORS

④ With CONSULT-II

1. Start engine.
2. Perform "POWER BALANCE" in "ACTIVE TEST" mode with CONSULT-II.
3. Make sure that each circuit produces a momentary engine speed drop.

ACTIVE TEST	
POWER BALANCE	
MONITOR	
ENG SPEED	XXX rpm
MAS A/F SE-B1	XXX V

PBIB0133E

⊗ Without CONSULT-II

1. Start engine.
2. Listen to each injector operating sound.

Clicking noise should be heard.

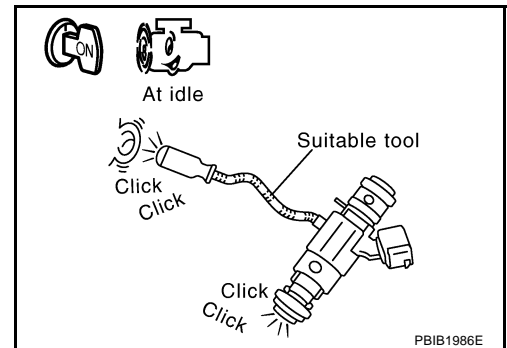

OK or NG

- OK >> GO TO 8.
 NG >> Perform trouble diagnosis for INJECTORS, [EC-597](#) .

8. CHECK INJECTOR

1. Remove injector assembly. Refer to [EM-45, "FUEL INJECTOR AND FUEL TUBE"](#) .
Keep fuel hose and all injectors connected to injector gallery.
2. Confirm that the engine is cooled down and there are no fire hazards near the vehicle.
3. Disconnect all injector harness connectors.
4. Disconnect all ignition coil harness connectors.
5. Prepare pans or saucers under each injectors.
6. Crank engine for about 3 seconds.
Make sure fuel does not drip from injector.

OK or NG

- OK (Does not drip.)>>GO TO 9.
 NG (Drips.)>>Replace the injectors from which fuel is dripping. Always replace O-ring with new one.

9. CHECK INTERMITTENT INCIDENT

Refer to [EC-135, "TROUBLE DIAGNOSIS FOR INTERMITTENT INCIDENT"](#) .

>> INSPECTION END

DTC P0181 FTT SENSOR

PFP:22630

Component Description

ABS006P6

The fuel tank temperature sensor is used to detect the fuel temperature inside the fuel tank. The sensor modifies a voltage signal from the ECM. The modified signal returns to the ECM as the fuel temperature input. The sensor uses a thermistor which is sensitive to the change in temperature. The electrical resistance of the thermistor decreases as temperature increases.

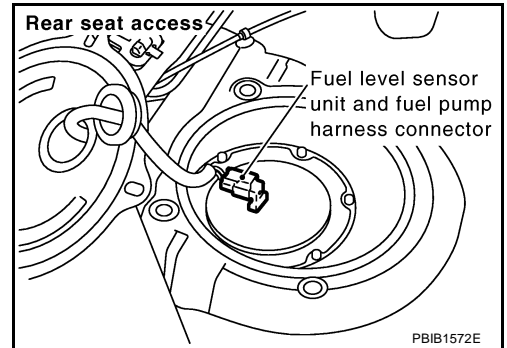

<Reference data>

Fluid temperature °C (°F)	Voltage* V	Resistance kΩ
20 (68)	3.5	2.3 - 2.7
50 (122)	2.2	0.79 - 0.90

*: This data is reference value and is measured between ECM terminal 107 (fuel tank temperature sensor) and ground.

CAUTION:

Do not use ECM ground terminals when measuring input/output voltage. Doing so may result in damage to the ECM's transistor. Use a ground other than ECM terminals, such as the ground.

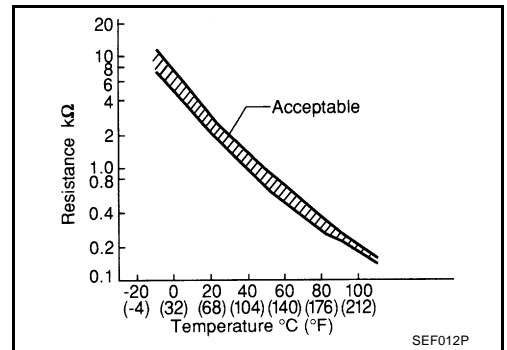

On Board Diagnosis Logic

ABS006P7

DTC No.	Trouble diagnosis name	DTC detecting condition	Possible cause
P0181 0181	Fuel tank temperature sensor circuit range/performance	Rationally incorrect voltage from the sensor is sent to ECM, compared with the voltage signals from engine coolant temperature sensor and intake air temperature sensor.	<ul style="list-style-type: none"> ● Harness or connectors (The sensor circuit is open or shorted) ● Fuel tank temperature sensor

DTC Confirmation Procedure

ABS006P8

NOTE:

If DTC Confirmation Procedure has been previously conducted, always turn ignition switch OFF and wait at least 10 seconds before conducting the next test.

WITH CONSULT-II

1. Turn ignition switch ON.
2. Select "DATA MONITOR" mode with CONSULT-II.
3. Wait at least 10 seconds.
If the result is NG, go to [EC-276, "Diagnostic Procedure"](#).
If the result is OK, go to following step.
4. Check "COOLAN TEMP/S" value.
If "COOLAN TEMP/S" is less than 60°C (140°F), the result will be OK.
If "COOLAN TEMP/S" is above 60°C (140°F), go to the following step.
5. Cool engine down until "COOLAN TEMP/S" is less than 60°C (140°F).
6. Wait at least 10 seconds.
7. If 1st trip DTC is detected, go to [EC-276, "Diagnostic Procedure"](#).

DATA MONITOR	
MONITOR	NO DTC
ENG SPEED	XXX rpm
COOLAN TEMP/S	XXX °C

SEF174Y

 **WITH GST**

Follow the procedure "WITH CONSULT-II" above.

DTC P0181 FTT SENSOR

[VQ35DE]

Wiring Diagram

ABS006P9

EC-FTTS-01

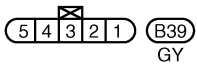
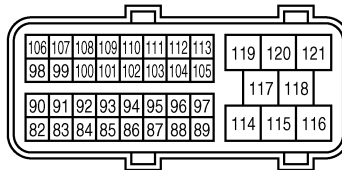
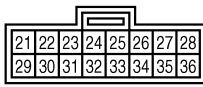
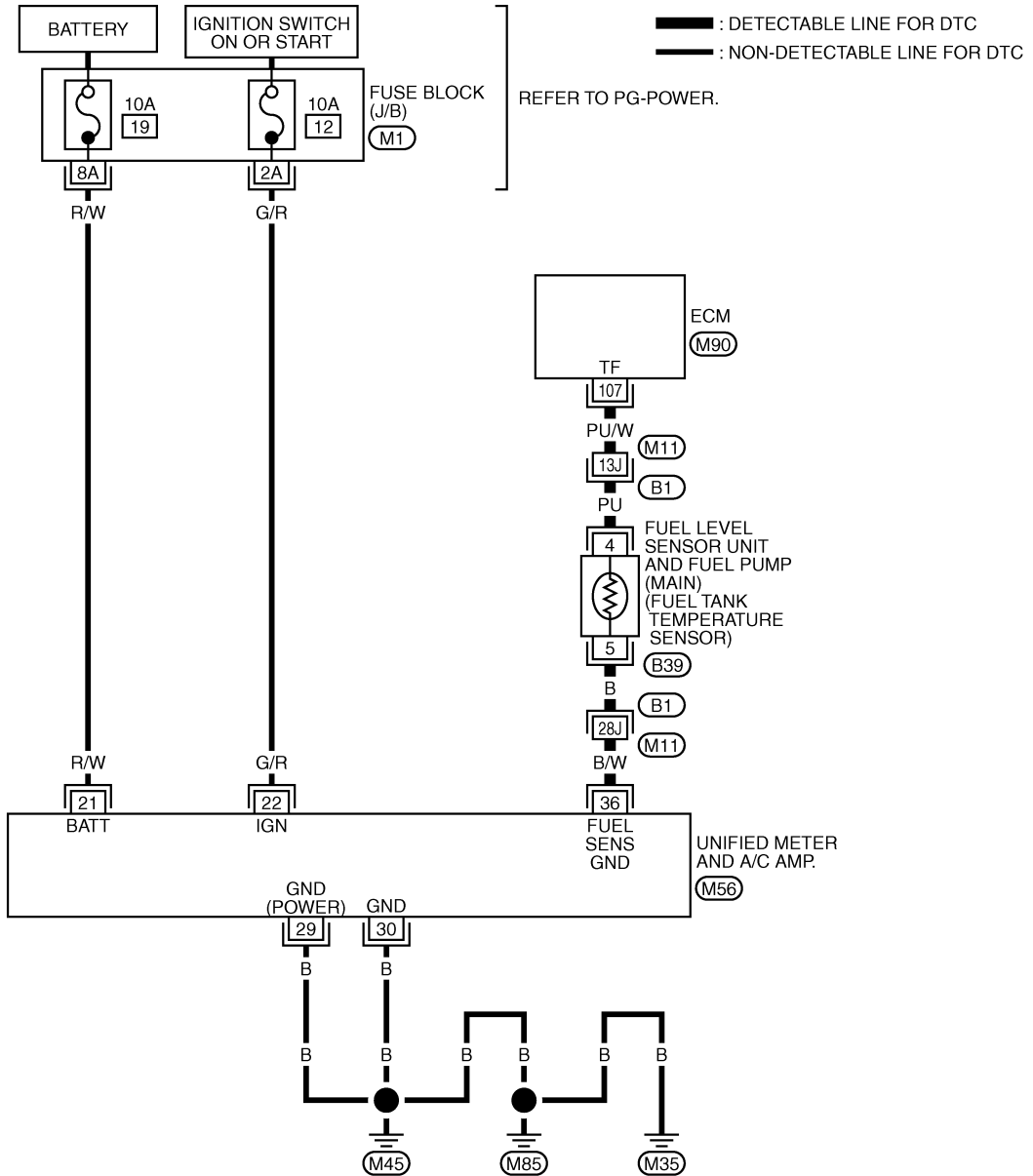

REFER TO THE FOLLOWING.

(B1) -SUPER MULTIPLE JUNCTION (SMJ)

(M1) -FUSE BLOCK-JUNCTION BOX (J/B)

TBWH0109E

Diagnostic Procedure

1. CHECK GROUND CONNECTIONS

1. Turn ignition switch OFF.
2. Loosen and retighten ground three screws on the body. Refer to [EC-141, "Ground Inspection"](#) .

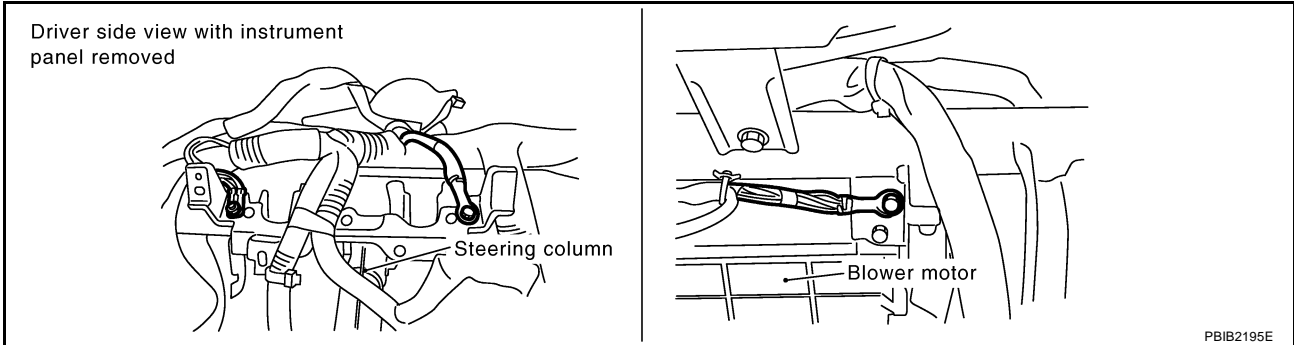

OK or NG

- OK >> GO TO 2.
- NG >> Repair or replace ground connections.

2. CHECK DTC WITH "UNIFIED METER AND A/C AMP."

Refer to [DI-32, "SELF-DIAGNOSTIC RESULTS"](#) .

OK or NG

- OK >> GO TO 3.
- NG >> Go to [DI-20, "Fuel Level Sensor Signal Inspection 1"](#) .

3. CHECK FUEL TANK TEMPERATURE SENSOR POWER SUPPLY CIRCUIT

1. Turn ignition switch OFF.
2. Disconnect "fuel level sensor unit and fuel pump" harness connector.
3. Turn ignition switch ON.

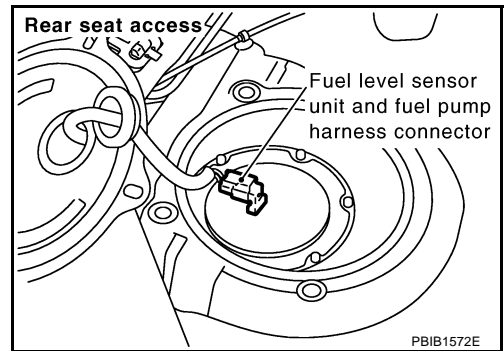

4. Check voltage between "fuel level sensor unit and fuel pump" terminal 4 and ground with CONSULT-II or tester.

Voltage: Approximately 5V

OK or NG

- OK >> GO TO 5.
- NG >> GO TO 4.

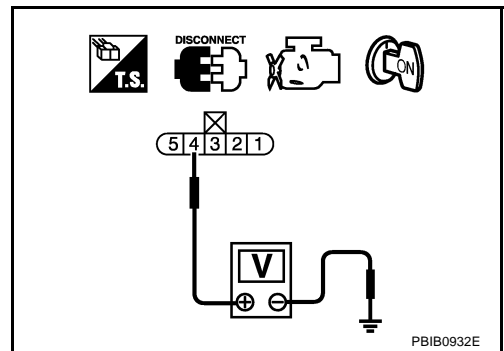

4. DETECT MALFUNCTIONING PART

Check the following.

- Harness connectors B1, M11
- Harness for open or short between ECM and “fuel level sensor unit and fuel pump”

>> Repair harness or connector.

5. CHECK FUEL TANK TEMPERATURE SENSOR GROUND CIRCUIT FOR OPEN AND SHORT

1. Turn ignition switch OFF.
2. Disconnect “unified meter and A/C amp.” harness connector.
3. Check harness continuity between “fuel level sensor unit and fuel pump” terminal 5 and “unified meter and A/C amp.” terminal 36. Refer to Wiring Diagram.

Continuity should exist.

4. Also check harness for short to ground and short to power.

OK or NG

- OK >> GO TO 7.
- NG >> GO TO 6.

6. DETECT MALFUNCTIONING PART

Check the following.

- Harness connectors B1, M11
- Harness for open or short between “fuel level sensor unit and fuel pump” and “unified meter and A/C amp.”

>> Repair open circuit or short to ground or short to power in harness or connector.

7. CHECK FUEL TANK TEMPERATURE SENSOR

Refer to [EC-277, "Component Inspection"](#) .

OK or NG

- OK >> GO TO 8.
- NG >> Replace fuel level sensor unit.

8. CHECK INTERMITTENT INCIDENT

Refer to [EC-135, "TROUBLE DIAGNOSIS FOR INTERMITTENT INCIDENT"](#) .

>> **INSPECTION END**

Component Inspection FUEL TANK TEMPERATURE SENSOR

ABS006PB

1. Remove fuel level sensor unit.

DTC P0181 FTT SENSOR

[VQ35DE]

2. Check resistance between fuel level sensor unit and fuel pump terminals 4 and 5 by heating with hot water or heat gun as shown in the figure.

Temperature °C (°F)	Resistance kΩ
20 (68)	2.3 - 2.7
50 (122)	0.79 - 0.90

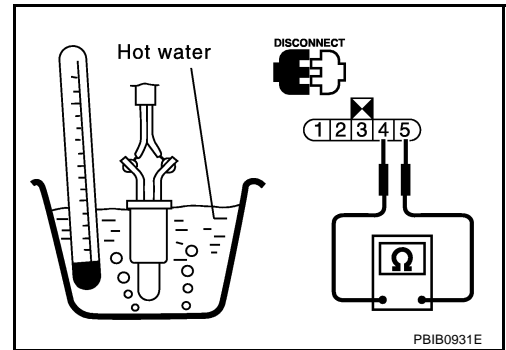

Removal and Installation FUEL TANK TEMPERATURE SENSOR

Refer to [FL-4, "FUEL LEVEL SENSOR UNIT, FUEL FILTER AND FUEL PUMP ASSEMBLY"](#) .

ABS006PC

DTC P0182, P0183 FTT SENSOR

PFP:22630

Component Description

ABS006PD

The fuel tank temperature sensor is used to detect the fuel temperature inside the fuel tank. The sensor modifies a voltage signal from the ECM. The modified signal returns to the ECM as the fuel temperature input. The sensor uses a thermistor which is sensitive to the change in temperature. The electrical resistance of the thermistor decreases as temperature increases.

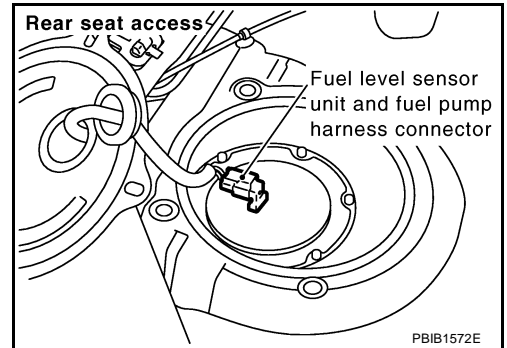

<Reference data>

Fluid temperature °C (°F)	Voltage* V	Resistance kΩ
20 (68)	3.5	2.3 - 2.7
50 (122)	2.2	0.79 - 0.90

*: This data is reference value and is measured between ECM terminal 107 (fuel tank temperature sensor) and ground.

CAUTION:

Do not use ECM ground terminals when measuring input/output voltage. Doing so may result in damage to the ECM's transistor. Use a ground other than ECM terminals, such as the ground.

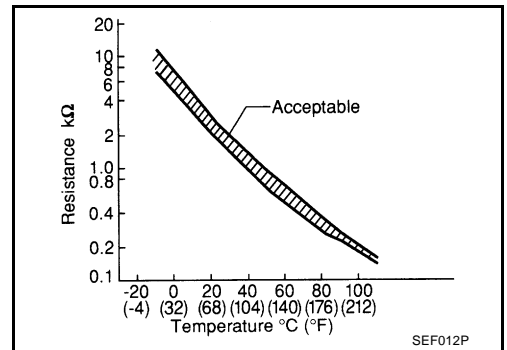

On Board Diagnosis Logic

ABS006PE

DTC No.	Trouble diagnosis name	DTC detecting condition	Possible cause
P0182 0182	Fuel tank temperature sensor circuit low input	An excessively low voltage from the sensor is sent to ECM.	<ul style="list-style-type: none"> ● Harness or connectors (The sensor circuit is open or shorted.) ● Fuel tank temperature sensor
P0183 0183	Fuel tank temperature sensor circuit high input	An excessively high voltage from the sensor is sent to ECM.	

DTC Confirmation Procedure

ABS006PF

NOTE:

If DTC Confirmation Procedure has been previously conducted, always turn ignition switch OFF and wait at least 10 seconds before conducting the next test.

WITH CONSULT-II

1. Turn ignition switch ON.
2. Select "DATA MONITOR" mode with CONSULT-II.
3. Wait at least 5 seconds.
4. If 1st trip DTC is detected, go to [EC-281, "Diagnostic Procedure"](#)

DATA MONITOR	
MONITOR	NO DTC
ENG SPEED	XXX rpm
COOLAN TEMP/S	XXX °C

SEF174Y

WITH GST

Follow the procedure "WITH CONSULT-II" above.

DTC P0182, P0183 FTT SENSOR

[VQ35DE]

ABS006PG

Wiring Diagram

EC-FTTS-01

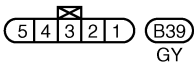
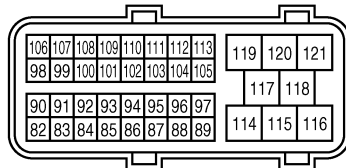
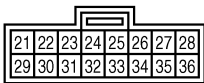
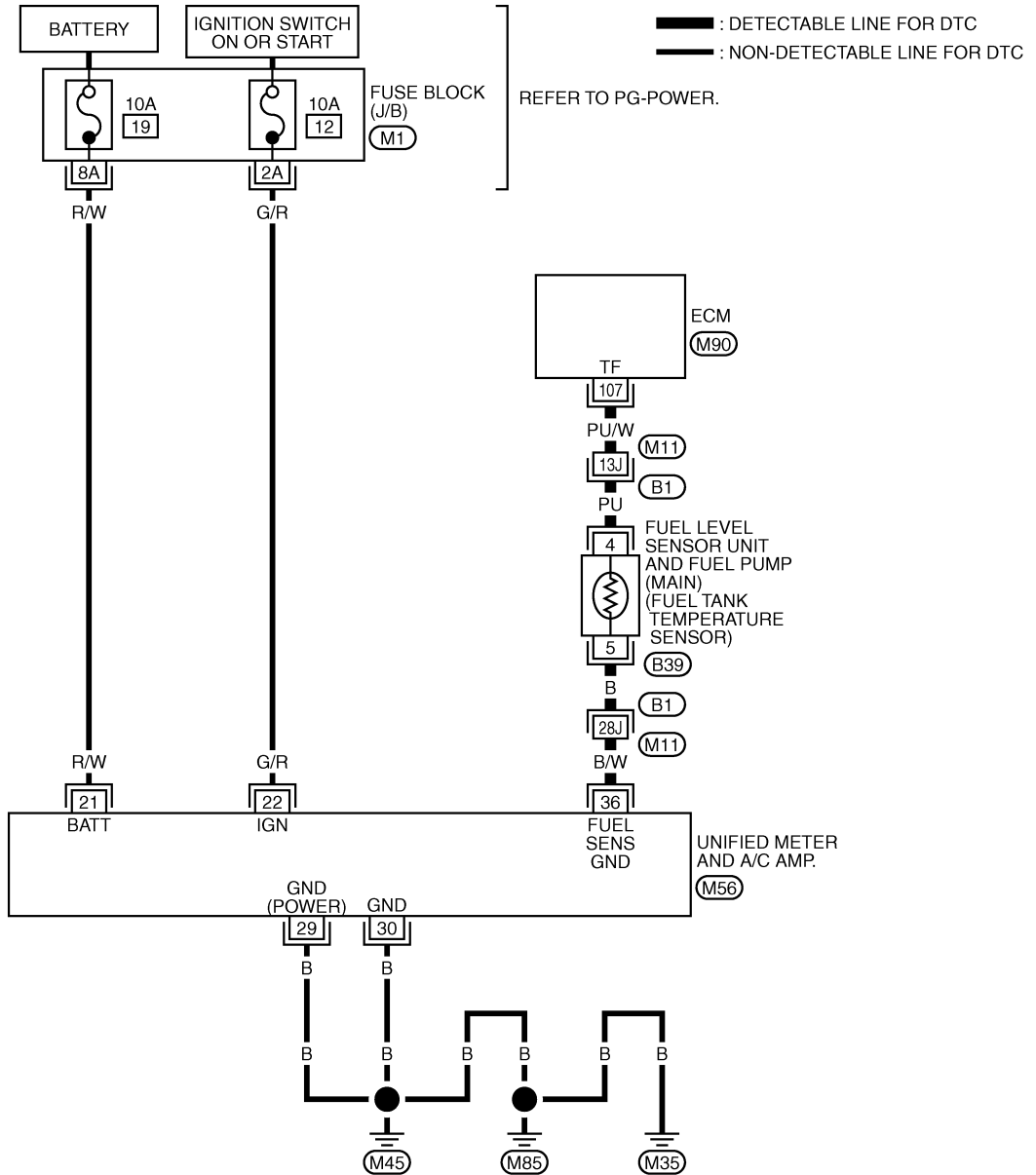

REFER TO THE FOLLOWING.

(B1) -SUPER MULTIPLE JUNCTION (SMJ)

(M1) -FUSE BLOCK-JUNCTION BOX (J/B)

TBWH0109E

Diagnostic Procedure

1. CHECK GROUND CONNECTIONS

1. Turn ignition switch OFF.
2. Loosen and retighten ground three screws on the body. Refer to [EC-141, "Ground Inspection"](#).

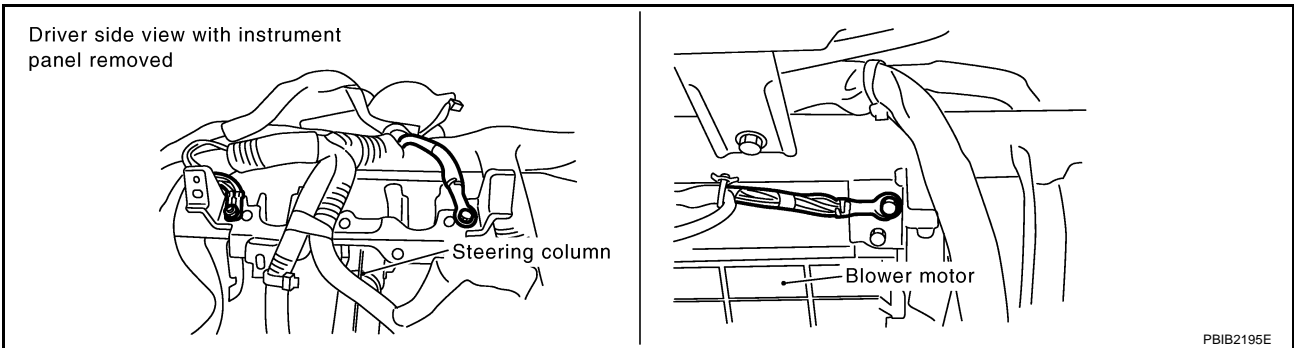

OK or NG

- OK >> GO TO 2.
- NG >> Repair or replace ground connections.

2. CHECK DTC WITH "UNIFIED METER AND A/C AMP."

Refer to [DI-32, "SELF-DIAGNOSTIC RESULTS"](#).

OK or NG

- OK >> GO TO 3.
- NG >> Go to [DI-20, "Fuel Level Sensor Signal Inspection 1"](#).

3. CHECK FUEL TANK TEMPERATURE SENSOR POWER SUPPLY CIRCUIT

1. Turn ignition switch OFF.
2. Disconnect "fuel level sensor unit and fuel pump" harness connector.
3. Turn ignition switch ON.

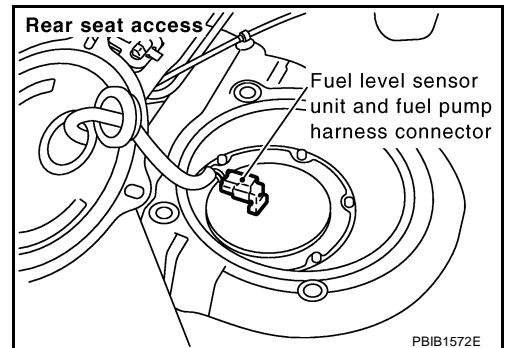

4. Check voltage between "fuel level sensor unit and fuel pump" terminal 4 and ground with CONSULT-II or tester.

Voltage: Approximately 5V

OK or NG

- OK >> GO TO 5.
- NG >> GO TO 4.

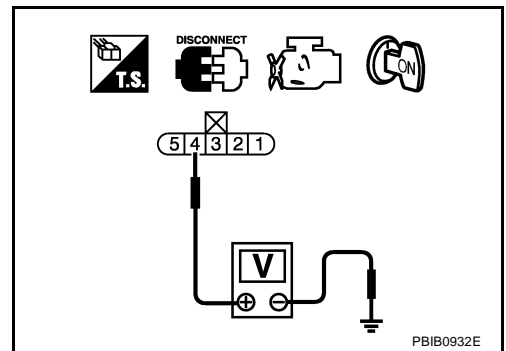

4. DETECT MALFUNCTIONING PART

Check the following.

- Harness connectors B1, M11
- Harness for open or short between ECM and “fuel level sensor unit and fuel pump”

>> Repair harness or connector.

5. CHECK FUEL TANK TEMPERATURE SENSOR GROUND CIRCUIT FOR OPEN AND SHORT

1. Turn ignition switch OFF.
2. Disconnect “unified meter and A/C amp.” harness connector.
3. Check harness continuity between “fuel level sensor unit and fuel pump” terminal 5 and “unified meter and A/C amp.” terminal 36. Refer to Wiring Diagram.

Continuity should exist.

4. Also check harness for short to ground and short to power.

OK or NG

- OK >> GO TO 7.
 NG >> GO TO 6.

6. DETECT MALFUNCTIONING PART

Check the following.

- Harness connectors B1, M11
- Harness for open or short between “fuel level sensor unit and fuel pump” and “unified meter and A/C amp.”

>> Repair open circuit or short to ground or short to power in harness or connector.

7. CHECK FUEL TANK TEMPERATURE SENSOR

Refer to [EC-282, "Component Inspection"](#) .

OK or NG

- OK >> GO TO 8.
 NG >> Replace fuel level sensor unit.

8. CHECK INTERMITTENT INCIDENT

Refer to [EC-135, "TROUBLE DIAGNOSIS FOR INTERMITTENT INCIDENT"](#) .

>> INSPECTION END

Component Inspection FUEL TANK TEMPERATURE SENSOR

ABS006PI

1. Remove fuel level sensor unit.

DTC P0182, P0183 FTT SENSOR

[VQ35DE]

2. Check resistance between fuel level sensor unit and fuel pump terminals 4 and 5 by heating with hot water or heat gun as shown in the figure.

Temperature °C (°F)	Resistance kΩ
20 (68)	2.3 - 2.7
50 (122)	0.79 - 0.90

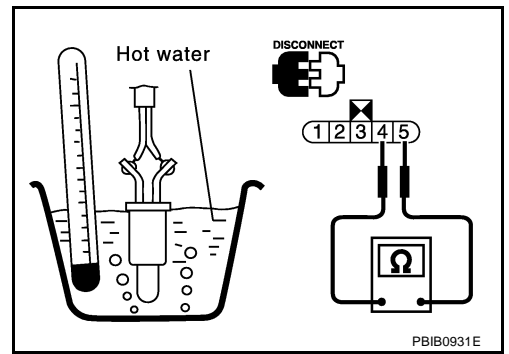

Removal and Installation FUEL TANK TEMPERATURE SENSOR

Refer to [FL-4, "FUEL LEVEL SENSOR UNIT, FUEL FILTER AND FUEL PUMP ASSEMBLY"](#) .

ABS006PJ

A
EC
C
D
E
F
G
H
I
J
K
L
M

DTC P0222, P0223 TP SENSOR

PFP:16119

Component Description

ABS00CH6

Electric throttle control actuator consists of throttle control motor, throttle position sensor, etc. The throttle position sensor responds to the throttle valve movement.

The throttle position sensor has the two sensors. These sensors are a kind of potentiometers which transform the throttle valve position into output voltage, and emit the voltage signal to the ECM. In addition, these sensors detect the opening and closing speed of the throttle valve and feed the voltage signals to the ECM. The ECM judges the current opening angle of the throttle valve from these signals and the ECM controls the throttle control motor to make the throttle valve opening angle properly in response to driving condition.

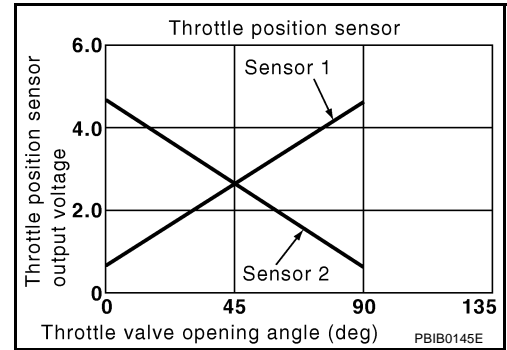

CONSULT-II Reference Value in Data Monitor Mode

ABS00CH7

Specification data are reference values.

MONITOR ITEM	CONDITION		SPECIFICATION
THRTL SEN1 THRTL SEN2*	<ul style="list-style-type: none"> Ignition switch: ON (Engine stopped) Shift lever: D 	Accelerator pedal: Fully released	More than 0.36V
		Accelerator pedal: Fully depressed	Less than 4.75V

*: Throttle position sensor 2 signal is converted by ECM internally. Thus, it differs from ECM terminal voltage signal.

On Board Diagnosis Logic

ABS00CH8

These self-diagnoses have the one trip detection logic.

DTC No.	Trouble diagnosis name	DTC detecting condition	Possible cause
P0222 0222	Throttle position sensor 1 circuit low input	An excessively low voltage from the TP sensor 1 is sent to ECM.	<ul style="list-style-type: none"> Harness or connectors (TP sensor 1 circuit is open or shorted.) (APP sensor 2 circuit is shorted.) Electric throttle control actuator (TP sensor 1) Accelerator pedal position sensor. (APP sensor 2)
P0223 0223	Throttle position sensor 1 circuit high input	An excessively high voltage from the TP sensor 1 is sent to ECM.	

FAIL-SAFE MODE

When the malfunction is detected, ECM enters fail-safe mode and the MIL lights up.

Engine operation condition in fail-safe mode

The ECM controls the electric throttle control actuator in regulating the throttle opening in order for the idle position to be within +10 degrees.
 The ECM regulates the opening speed of the throttle valve to be slower than the normal condition.
 So, the acceleration will be poor.

DTC Confirmation Procedure

NOTE:

If DTC Confirmation Procedure has been previously conducted, always turn ignition switch OFF and wait at least 10 seconds before conducting the next test.

TESTING CONDITION:

Before performing the following procedure, confirm that battery voltage is more than 10V at idle.

WITH CONSULT-II

1. Turn ignition switch ON.
2. Select "DATA MONITOR" mode with CONSULT-II.
3. Start engine and let it idle for 1 second.
4. If DTC is detected, go to [EC-287, "Diagnostic Procedure"](#) .

DATA MONITOR	
MONITOR	NO DTC
ENG SPEED	XXX rpm

SEF058Y

WITH GST

Follow the procedure "WITH CONSULT-II" above.

A
EC
C
D
E
F
G
H
I
J
K
L
M

DTC P0222, P0223 TP SENSOR

[VQ35DE]

Wiring Diagram

ABS00CHA

EC-TPS1-01

: DETECTABLE LINE FOR DTC
 : NON-DETECTABLE LINE FOR DTC

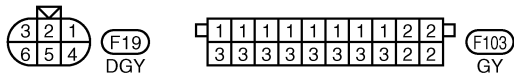
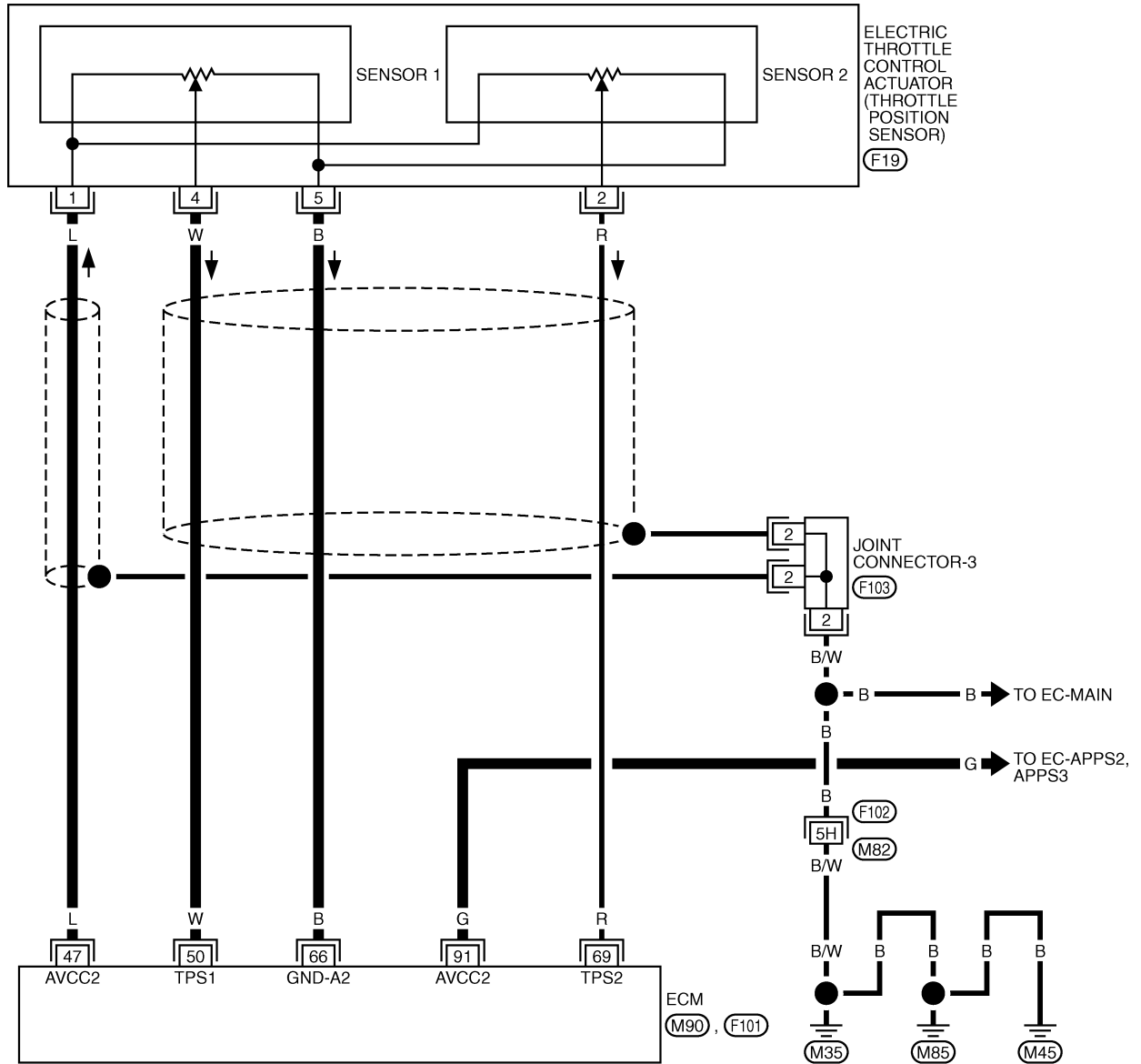

REFER TO THE FOLLOWING.

(F102) -SUPER MULTIPLE JUNCTION (SMJ)

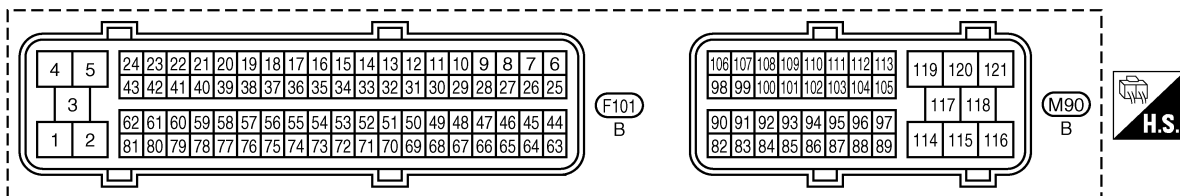

TBWM0428E

DTC P0222, P0223 TP SENSOR

[VQ35DE]

Specification data are reference values and are measured between each terminal and ground.

CAUTION:

Do not use ECM ground terminals when measuring input/output voltage. Doing so may result in damage to the ECM's transistor. Use a ground other than ECM terminals, such as the ground.

TER-MINAL NO.	WIRE COLOR	ITEM	CONDITION	DATA (DC Voltage)
47	L	Sensor power supply (Throttle position sensor)	[Ignition switch: ON]	Approximately 5V
50	W	Throttle position sensor 1	[Ignition switch: ON] <ul style="list-style-type: none"> ● Engine stopped ● Shift lever: D ● Accelerator pedal: Fully released 	More than 0.36V
			[Ignition switch: ON] <ul style="list-style-type: none"> ● Engine stopped ● Shift lever: D ● Accelerator pedal: Fully depressed 	Less than 4.75V
66	B	Sensor ground (Throttle position sensor)	[Engine is running] <ul style="list-style-type: none"> ● Warm-up condition ● Idle speed 	Approximately 0V
69	R	Throttle position sensor 2	[Ignition switch: ON] <ul style="list-style-type: none"> ● Engine stopped ● Shift lever: D ● Accelerator pedal: Fully released 	Less than 4.75V
			[Ignition switch: ON] <ul style="list-style-type: none"> ● Engine stopped ● Shift lever: D ● Accelerator pedal: Fully depressed 	More than 0.36V
91	G	Sensor power supply (APP sensor 2)	[Ignition switch: ON]	Approximately 5V

Diagnostic Procedure

ABS00CHB

1. CHECK GROUND CONNECTIONS

1. Turn ignition switch OFF.
2. Loosen and retighten ground three screws on the body. Refer to [EC-141, "Ground Inspection"](#) .

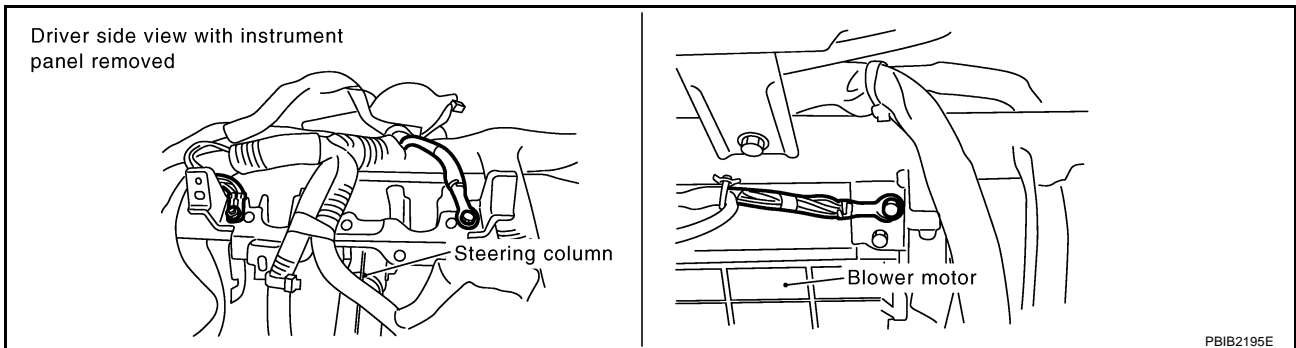

PBIB2195E

OK or NG

- OK >> GO TO 2.
- NG >> Repair or replace ground connections.

2. CHECK THROTTLE POSITION SENSOR 1 POWER SUPPLY CIRCUIT-I

1. Disconnect electric throttle control actuator harness connector.
2. Turn ignition switch ON.

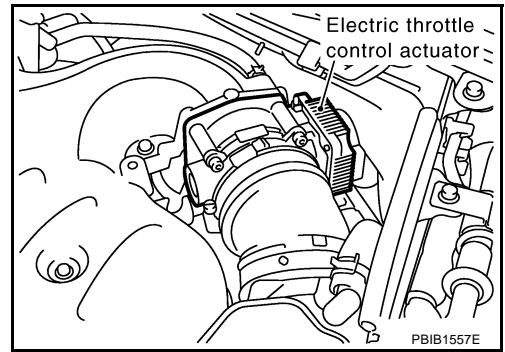

3. Check voltage between electric throttle control actuator terminal 1 and ground with CONSULT-II or tester.

Voltage: Approximately 5V

OK or NG

- OK >> GO TO 7.
 NG >> GO TO 3.

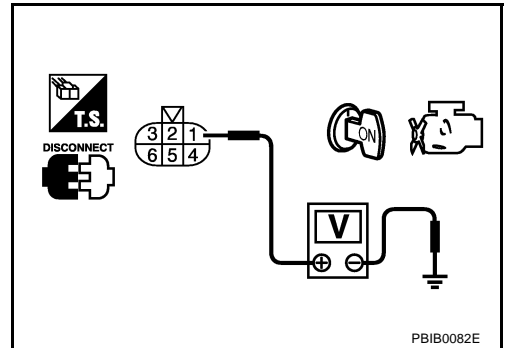

3. CHECK THROTTLE POSITION SENSOR 1 POWER SUPPLY CIRCUIT-II

1. Turn ignition switch OFF.
2. Disconnect ECM harness connector.
3. Check harness continuity between electric throttle control actuator terminal 1 and ECM terminal 47. Refer to Wiring Diagram.

Continuity should exist.

OK or NG

- OK >> GO TO 4.
 NG >> Repair or replace open circuit.

4. CHECK THROTTLE POSITION SENSOR 1 POWER SUPPLY CIRCUIT-III

Check the following.

- Harness for short to power and short to ground, between the following terminals.

ECM terminal	Sensor terminal	Reference Wiring Diagram
47	Electric throttle control actuator terminal 1	EC-286
91	APP sensor terminal 2	EC-564

OK or NG

- OK >> GO TO 5.
 NG >> Repair short to ground or short to power in harness or connectors.

5. CHECK APP SENSOR

Refer to [EC-568, "Component Inspection"](#).

OK or NG

- OK >> GO TO 11.
 NG >> GO TO 6.

6. REPLACE ACCELERATOR PEDAL ASSEMBLY

1. Replace accelerator pedal assembly.
2. Perform [EC-49, "Accelerator Pedal Released Position Learning"](#) .
3. Perform [EC-49, "Throttle Valve Closed Position Learning"](#) .
4. Perform [EC-49, "Idle Air Volume Learning"](#) .

>> INSPECTION END

7. CHECK THROTTLE POSITION SENSOR 1 GROUND CIRCUIT FOR OPEN AND SHORT

1. Turn ignition switch OFF.
2. Disconnect ECM harness connector.
3. Check harness continuity between electric throttle control actuator terminal 5 and ECM terminal 66.
Refer to Wiring Diagram.

Continuity should exist.

4. Also check harness for short to ground and short to power.

OK or NG

OK >> GO TO 8.

NG >> Repair open circuit or short to ground or short to power in harness or connectors.

8. CHECK THROTTLE POSITION SENSOR 1 INPUT SIGNAL CIRCUIT FOR OPEN AND SHORT

1. Check harness continuity between ECM terminal 50 and electric throttle control actuator terminal 4.
Refer to Wiring Diagram.

Continuity should exist.

2. Also check harness for short to ground and short to power.

OK or NG

OK >> GO TO 9.

NG >> Repair open circuit or short to ground or short to power in harness or connectors.

9. CHECK THROTTLE POSITION SENSOR

Refer to [EC-290, "Component Inspection"](#) .

OK or NG

OK >> GO TO 11.

NG >> GO TO 10.

10. REPLACE ELECTRIC THROTTLE CONTROL ACTUATOR

1. Replace the electric throttle control actuator.
2. Perform [EC-49, "Throttle Valve Closed Position Learning"](#) .
3. Perform [EC-49, "Idle Air Volume Learning"](#) .

>> INSPECTION END

11. CHECK INTERMITTENT INCIDENT

Refer to [EC-135, "TROUBLE DIAGNOSIS FOR INTERMITTENT INCIDENT"](#) .

>> INSPECTION END

Component Inspection
THROTTLE POSITION SENSOR

1. Reconnect all harness connectors disconnected.
2. Perform [EC-49, "Throttle Valve Closed Position Learning"](#) .
3. Turn ignition switch ON.
4. Set selector lever to D position.
5. Check voltage between ECM terminals 50 (TP sensor 1 signal), 69 (TP sensor 2 signal) and ground under the following conditions.

Terminal	Accelerator pedal	Voltage
50 (Throttle position sensor 1)	Fully released	More than 0.36V
	Fully depressed	Less than 4.75V
69 (Throttle position sensor 2)	Fully released	Less than 4.75V
	Fully depressed	More than 0.36V

6. If NG, replace electric throttle control actuator and go to the next step.
7. Perform [EC-49, "Throttle Valve Closed Position Learning"](#) .
8. Perform [EC-49, "Idle Air Volume Learning"](#) .

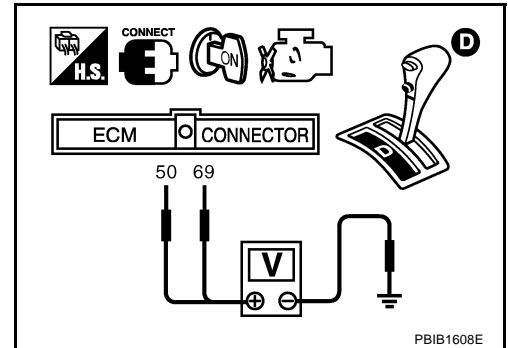

PBIB1608E

Removal and Installation
ELECTRIC THROTTLE CONTROL ACTUATOR

Refer to [EM-174, "INTAKE MANIFOLD"](#) .

DTC P0300 - P0306 MULTIPLE CYLINDER MISFIRE, NO. 1 - 6 CYLINDER MISFIRE

[VQ35DE]

DTC P0300 - P0306 MULTIPLE CYLINDER MISFIRE, NO. 1 - 6 CYLINDER MISFIRE

PF0:00000

On Board Diagnosis Logic

ABS006PS

When a misfire occurs, engine speed will fluctuate. If the engine speed fluctuates enough to cause the crankshaft position (CKP) sensor (POS) signal to vary, ECM can determine that a misfire is occurring.

Sensor	Input Signal to ECM	ECM function
Crankshaft position sensor (POS)	Engine speed	On board diagnosis of misfire

The misfire detection logic consists of the following two conditions.

- One Trip Detection Logic (Three Way Catalyst Damage)**
 On the first trip that a misfire condition occurs that can damage the three way catalyst (TWC) due to overheating, the MIL will blink.
 When a misfire condition occurs, the ECM monitors the CKP sensor signal every 200 engine revolutions for a change.
 When the misfire condition decreases to a level that will not damage the TWC, the MIL will turn off.
 If another misfire condition occurs that can damage the TWC on a second trip, the MIL will blink.
 When the misfire condition decreases to a level that will not damage the TWC, the MIL will remain on.
 If another misfire condition occurs that can damage the TWC, the MIL will begin to blink again.
- Two Trip Detection Logic (Exhaust quality deterioration)**
 For misfire conditions that will not damage the TWC (but will affect vehicle emissions), the MIL will only light when the misfire is detected on a second trip. During this condition, the ECM monitors the CKP sensor signal every 1,000 engine revolutions.
 A misfire malfunction can be detected on any one cylinder or on multiple cylinders.

DTC No.	Trouble diagnosis name	DTC detecting condition	Possible cause
P0300 0300	Multiple cylinder misfire detected	Multiple cylinder misfire.	<ul style="list-style-type: none"> ● Improper spark plug ● Insufficient compression ● Incorrect fuel pressure ● The injector circuit is open or shorted ● Fuel injector ● Intake air leak ● The ignition signal circuit is open or shorted ● Lack of fuel ● Signal plate ● Heated oxygen sensor 1 ● Incorrect PCV hose connection
P0301 0301	No.1 cylinder misfire detected	No. 1 cylinder misfires.	
P0302 0302	No. 2 cylinder misfire detected	No. 2 cylinder misfires.	
P0303 0303	No. 3 cylinder misfire detected	No. 3 cylinder misfires.	
P0304 0304	No. 4 cylinder misfire detected	No. 4 cylinder misfires.	
P0305 0305	No. 5 cylinder misfire detected	No. 5 cylinder misfires.	
P0306 0306	No. 6 cylinder misfire detected	No. 6 cylinder misfires.	

DTC Confirmation Procedure

ABS0095P

CAUTION:

Always drive vehicle in safe manner according to traffic conditions and obey all traffic laws when driving.

NOTE:

If DTC Confirmation Procedure has been previously conducted, always turn ignition switch OFF and wait at least 10 seconds before conducting the next test.

WITH CONSULT-II

1. Turn ignition switch ON, and select "DATA MONITOR" mode with CONSULT-II.
2. Start engine and warm it up to normal operating temperature.
3. Turn ignition switch OFF and wait at least 10 seconds.
4. Restart engine and let it idle for about 15 minutes.
5. If 1st trip DTC is detected, go to [EC-292, "Diagnostic Procedure"](#)

DATA MONITOR	
MONITOR	NO DTC
ENG SPEED	XXX rpm
COOLAN TEMP/S	XXX °C
VHCL SPEED SE	XXX km/h
B/FUEL SCHDL	XXX msec
PBIB0164E	

NOTE:

If 1st trip DTC is not detected during above procedure, performing the following procedure is advised.

1. Turn ignition switch OFF and wait at least 10 seconds.
2. Start engine and drive the vehicle under the similar conditions to (1st trip) Freeze Frame Data for a certain time. Refer to table below.

Hold the accelerator pedal as steady as possible.

The similar conditions to (1st trip) Freeze Frame Data means the vehicle operation that the following conditions should be satisfied at the same time.

Engine speed	Engine speed in the freeze frame data ± 400 rpm
Vehicle speed	Vehicle speed in the freeze frame data ± 10 km/h (6 MPH)
Engine coolant temperature (T) condition	When the freeze frame data shows lower than 70 °C (158 °F), T should be lower than 70 °C (158 °F).
	When the freeze frame data shows higher than or equal to 70 °C (158 °F), T should be higher than or equal to 70 °C (158 °F).

The time to driving varies according to the engine speed in the freeze frame data. Refer to the following table.

Engine speed	Time
Around 1,000 rpm	Approximately 10 minutes
Around 2,000 rpm	Approximately 5 minutes
More than 3,000 rpm	Approximately 3.5 minutes

WITH GST

Follow the procedure "WITH CONSULT-II" above.

Diagnostic Procedure

ABS006PU

1. CHECK FOR INTAKE AIR LEAK AND PCV HOSE

1. Start engine and run it at idle speed.
2. Listen for the sound of the intake air leak.
3. Check PCV hose connection.

OK or NG

- OK >> GO TO 2.
 NG >> Discover air leak location and repair.

2. CHECK FOR EXHAUST SYSTEM CLOGGING

Stop engine and visually check exhaust tube, three way catalyst and muffler for dents.

OK or NG

- OK >> GO TO 3.
 NG >> Repair or replace it.

3. PERFORM POWER BALANCE TEST

With CONSULT-II

1. Perform "POWER BALANCE" in "ACTIVE TEST" mode.
2. Is there any cylinder which does not produce a momentary engine speed drop?

ACTIVE TEST	
POWER BALANCE	
MONITOR	
ENG SPEED	XXX rpm
MAS A/F SE-B1	XXX V

PBIB0133E

Without CONSULT-II

When disconnecting each injector harness connector one at a time, is there any cylinder which does not produce a momentary engine speed drop?

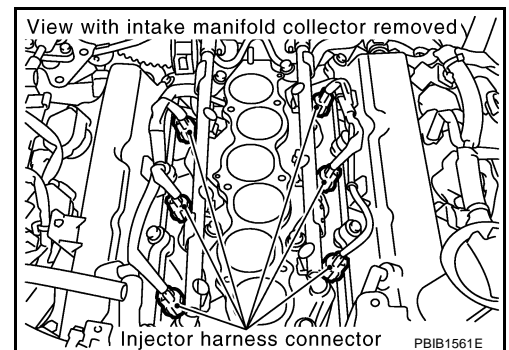

Yes or No

- Yes >> GO TO 4.
- No >> GO TO 7.

4. CHECK INJECTOR

Does each injector make an operating sound at idle?

Yes or No

- Yes >> GO TO 5.
- No >> Check injector(s) and circuit(s). Refer to [EC-597](#). "[INJECTOR CIRCUIT](#)".

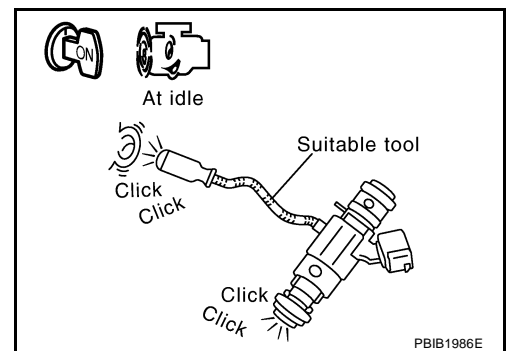

5. CHECK IGNITION SPARK

1. Remove ignition coil assembly from rocker cover.
2. Remove spark plug from ignition coil assembly
3. Connect a known-good spark plug to the ignition coil.
4. Disconnect all injector harness connectors.
5. Place end of spark plug against a suitable ground and crank engine.
6. Check for spark.

OK or NG

OK >> GO TO 6.

NG >> Check ignition coil, power transistor and their circuits.
Refer to [EC-585, "IGNITION SIGNAL"](#) .

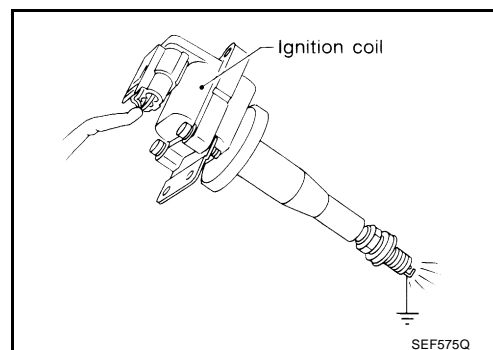

6. CHECK SPARK PLUGS

Remove the spark plugs and check for fouling, etc.

OK or NG

OK >> GO TO 7.

NG >> Repair or replace spark plug(s) with standard type one(s). For spark plug type, refer to, [MA-14, "ENGINE MAINTENANCE \(VQ35DE ENGINE\)"](#) .

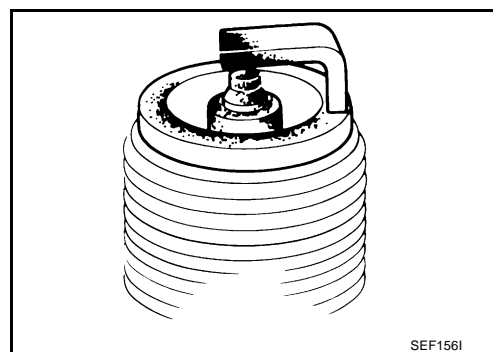

7. CHECK COMPRESSION PRESSURE

Check compression pressure. Refer to [EM-98, "CHECKING COMPRESSION PRESSURE"](#) .

Standard: 1,275 kPa (13.0 kg/cm² , 185 psi)/300 rpm

Minimum: 981 kPa (10.0 kg/cm² , 142 psi)/300 rpm

Difference between each cylinder: 98 kPa (1.0 kg/cm² , 14 psi)/300 rpm

OK or NG

OK >> GO TO 8.

NG >> Check pistons, piston rings, valves, valve seats and cylinder head gaskets.

8. CHECK FUEL PRESSURE

1. Install all removed parts.
2. Release fuel pressure to zero. Refer to [EC-51, "FUEL PRESSURE RELEASE"](#) .
3. Install fuel pressure gauge and check fuel pressure. Refer to [EC-52, "FUEL PRESSURE CHECK"](#) .

At idle: Approx. 350 kPa (3.57 kg/cm² , 51 psi)

OK or NG

OK >> GO TO 10.

NG >> GO TO 9.

9. DETECT MALFUNCTIONING PART

Check the following.

- Fuel pump and circuit (Refer to [EC-603](#) .)
- Fuel pressure regulator (Refer to [EC-51](#) .)
- Fuel lines
- Fuel filter for clogging

>> Repair or replace.

10. CHECK IGNITION TIMING

Check the following items. Refer to [EC-83, "Basic Inspection"](#) .

Items	Specifications
Target idle speed	650 ± 50 rpm (in P or N position)
Ignition timing	15 ± 5° BTDC (in P or N position)

OK or NG

OK >> GO TO 11.

NG >> Follow the [EC-83, "Basic Inspection"](#) .

11. CHECK HEATED OXYGEN SENSOR 1 (BANK 1)/(BANK 2)

Refer to [EC-212, "Component Inspection"](#) .

OK or NG

OK >> GO TO 12.

NG >> Replace (malfunctioning) heated oxygen sensor 1.

12. CHECK MASS AIR FLOW SENSOR

 **With CONSULT-II**

Check mass air flow sensor signal in "DATA MONITOR" mode with CONSULT-II.

2.0 - 6.0 g-m/sec: at idling

7.0 - 20.0 g-m/sec: at 2,500 rpm

 **With GST**

Check mass air flow sensor signal in MODE 1 with GST.

2.0 - 6.0 g-m/sec: at idling

7.0 - 20.0 g-m/sec: at 2,500 rpm

OK or NG

OK >> GO TO 13.

NG >> Check connectors for rusted terminals or loose connections in the mass air flow sensor circuit or ground. Refer to [EC-165, "DTC P0101 MAF SENSOR"](#) .

13. CHECK SYMPTOM MATRIX CHART

Check items on the rough idle symptom in [EC-88, "Symptom Matrix Chart"](#) .

OK or NG

OK >> GO TO 14.

NG >> Repair or replace.

14. ERASE THE 1ST TRIP DTC

Some tests may cause a 1st trip DTC to be set.

Erase the 1st trip DTC from the ECM memory after performing the tests. Refer to [EC-67, "HOW TO ERASE EMISSION-RELATED DIAGNOSTIC INFORMATION"](#) .

>> GO TO 15.

15. CHECK INTERMITTENT INCIDENT

Refer to [EC-135, "TROUBLE DIAGNOSIS FOR INTERMITTENT INCIDENT"](#) .

>> **INSPECTION END**

DTC P0327, P0328 KS

PFP:22060

Component Description

ABS006PV

The knock sensor is attached to the cylinder block. It senses engine knocking using a piezoelectric element. A knocking vibration from the cylinder block is sensed as vibrational pressure. This pressure is converted into a voltage signal and sent to the ECM.

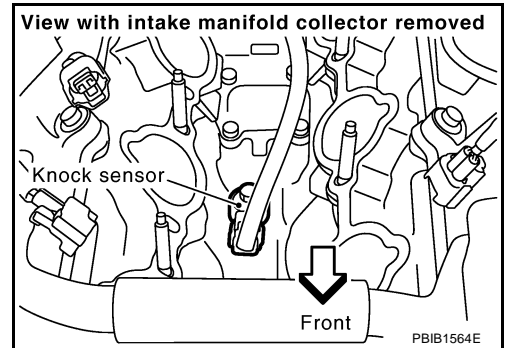

On Board Diagnosis Logic

ABS006PW

The MIL will not light up for these diagnoses.

DTC No.	Trouble diagnosis name	DTC detected condition	Possible cause
P0327 0327	Knock sensor circuit low input	An excessively low voltage from the sensor is sent to ECM.	<ul style="list-style-type: none"> ● Harness or connectors (The sensor circuit is open or shorted.) ● Knock sensor
P0328 0328	Knock sensor circuit high input	An excessively high voltage from the sensor is sent to ECM.	

DTC Confirmation Procedure

ABS006PX

NOTE:

If DTC Confirmation Procedure has been previously conducted, always turn ignition switch OFF and wait at least 10 seconds before conducting the next test.

TESTING CONDITION:

Before performing the following procedure, confirm that battery voltage is more than 10V at idle.

WITH CONSULT-II

1. Turn ignition switch ON and select "DATA MONITOR" mode with CONSULT-II.
2. Start engine and run it for at least 5 seconds at idle speed.
3. If 1st trip DTC is detected, go to [EC-299, "Diagnostic Procedure"](#)

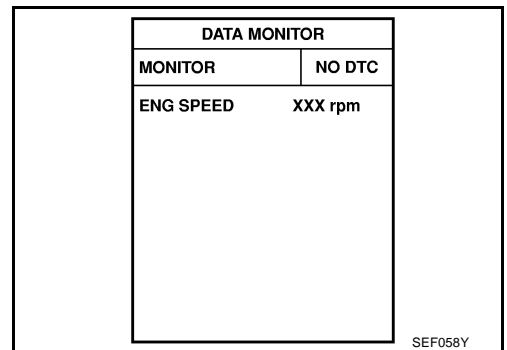

WITH GST

Follow the procedure "WITH CONSULT-II" above.

Wiring Diagram

EC-KS-01

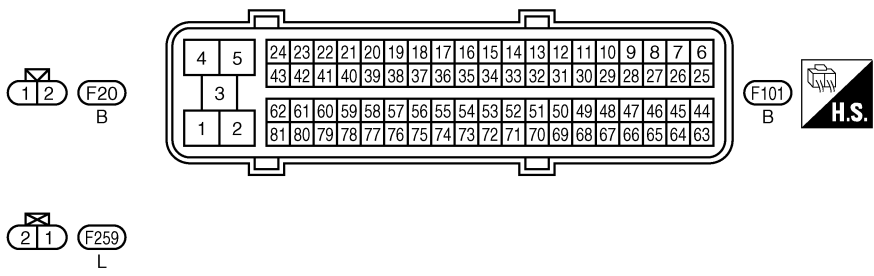
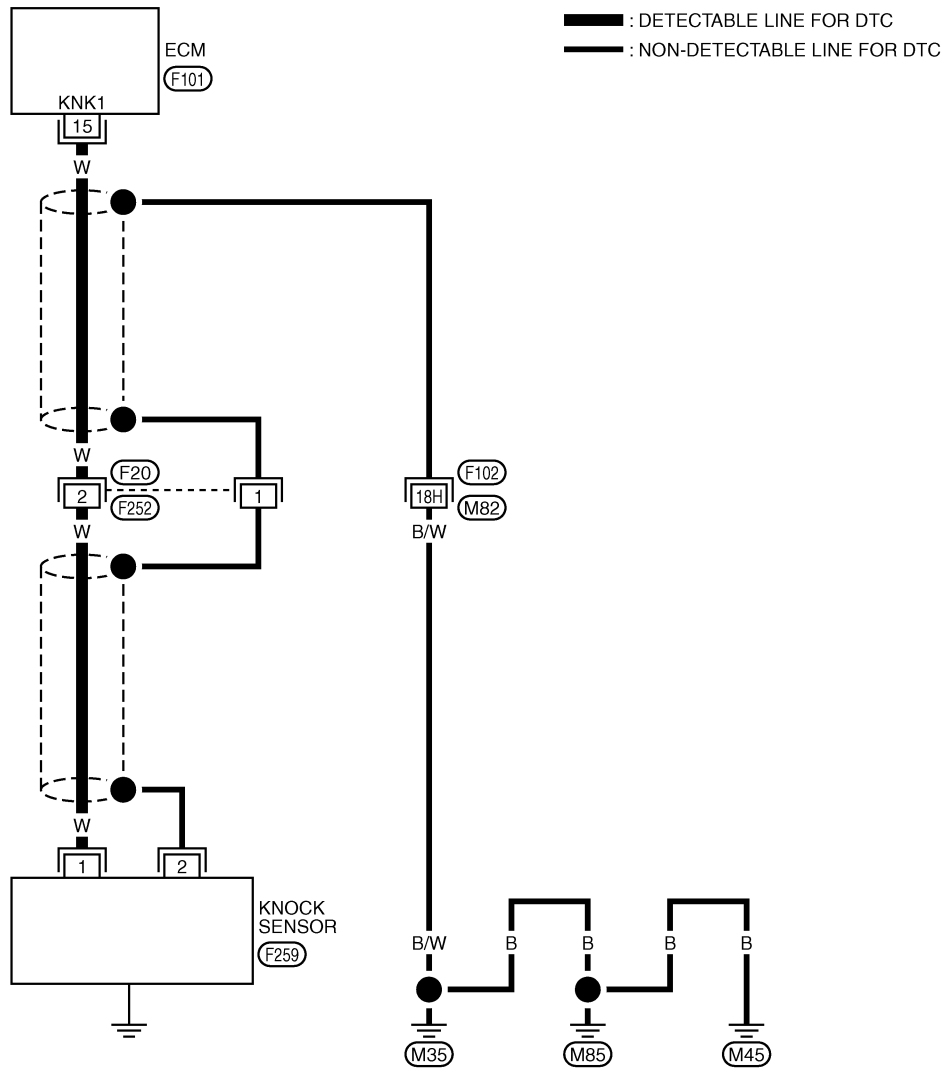

REFER TO THE FOLLOWING.
 (F102) -SUPER MULTIPLE
 JUNCTION (SMJ)

Specification data are reference values and are measured between each terminal and ground.

CAUTION:

Do not use ECM ground terminals when measuring input/output voltage. Doing so may result in damage to the ECM's transistor. Use a ground other than ECM terminals, such as the ground.

TER-MINAL NO.	WIRE COLOR	ITEM	CONDITION	DATA (DC Voltage)
15	W	Knock sensor	[Engine is running] ● Idle speed	Approximately 2.5V

Diagnostic Procedure

ABS00CHE

1. CHECK KNOCK SENSOR INPUT SIGNAL CIRCUIT FOR OPEN AND SHORT-I

1. Turn ignition switch OFF.
2. Disconnect ECM harness connector.
3. Check resistance between ECM terminal 15 and ground. Refer to Wiring Diagram.

NOTE:

It is necessary to use an ohmmeter which can measure more than 10 MΩ.

Resistance: Approximately 532 - 588 kΩ [at 20°C (68°F)]

4. Also check harness for short to ground and short to power.

OK or NG

- OK >> GO TO 4.
- NG >> GO TO 2.

2. CHECK KNOCK SENSOR INPUT SIGNAL CIRCUIT FOR OPEN AND SHORT-II

1. Disconnect knock sensor harness connector.
2. Check harness continuity between ECM terminal 15 and knock sensor terminal 1. Refer to Wiring Diagram.

Continuity should exist.

3. Also check harness for short to ground and short to power.

OK or NG

- OK >> GO TO 4.
- NG >> GO TO 3.

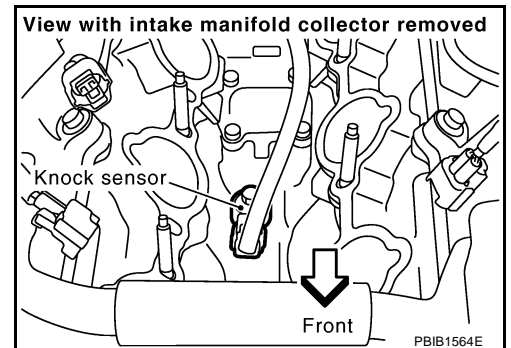

3. DETECT MALFUNCTIONING PART

Check the following.

- Harness connectors F20, F252
- Harness for open or short between ECM and knock sensor

>> Repair open circuit or short to ground or short to power in harness or connectors.

4. CHECK KNOCK SENSOR

Refer to [EC-300, "Component Inspection"](#).

OK or NG

- OK >> GO TO 5.
- NG >> Replace knock sensor.

5. CHECK GROUND CONNECTIONS

Loosen and retighten ground three screws on the body. Refer to [EC-141, "Ground Inspection"](#) .

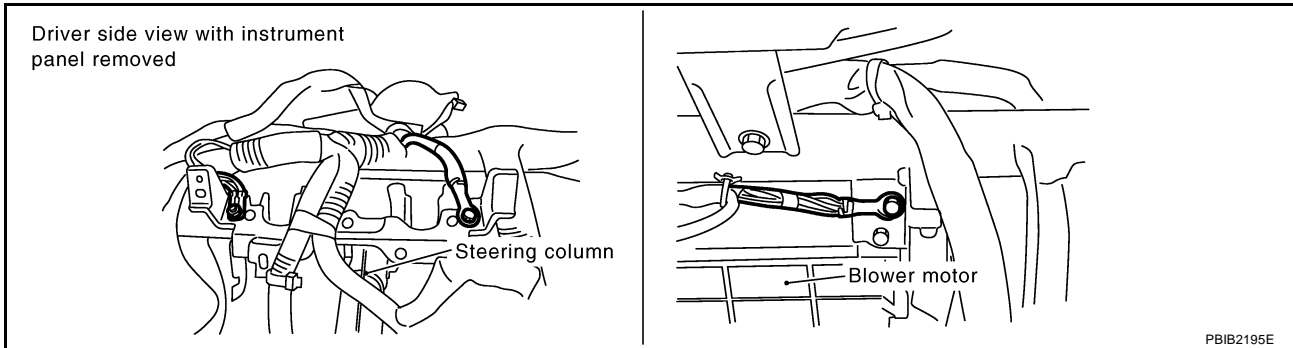

OK or NG

- OK >> GO TO 6.
- NG >> Repair or replace ground connections.

6. CHECK KNOCK SENSOR SHIELD CIRCUIT FOR OPEN AND SHORT

1. Turn ignition switch OFF.
2. Disconnect knock sensor harness connector.
3. Check harness continuity between knock sensor terminal 2 and ground. Refer to Wiring Diagram.

Continuity should exist.

OK or NG

- OK >> GO TO 8.
- NG >> GO TO 7.

7. DETECT MALFUNCTIONING PART

Check the following.

- Harness connectors F20, F252
- Harness connectors F102, M82
- Harness for open or short between knock sensor terminal 2 and ground

>> Repair open circuit or short power in harness or connectors.

8. CHECK INTERMITTENT INCIDENT

Refer to [EC-135, "TROUBLE DIAGNOSIS FOR INTERMITTENT INCIDENT"](#) .

>> INSPECTION END

Component Inspection KNOCK SENSOR

ABS00600

Check resistance between knock sensor terminal 1 and ground.

NOTE:

It is necessary to use an ohmmeter which can measure more than 10 M Ω .

Resistance: Approximately 532 - 588 k Ω [at 20°C (68°F)]

CAUTION:

Do not use any knock sensors that have been dropped or physically damaged. Use only new ones.

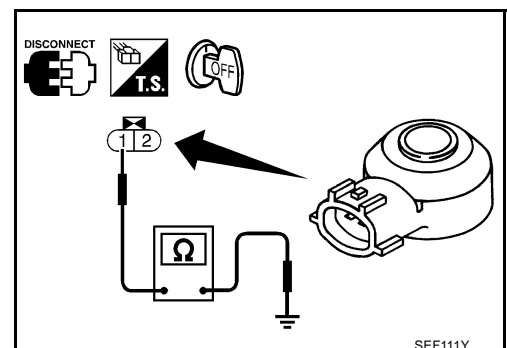

Removal and Installation
KNOCK SENSOR

Refer to [EM-240, "CYLINDER BLOCK"](#) .

A

EC

C

D

E

F

G

H

I

J

K

L

M

DTC P0335 CKP SENSOR (POS)

PFP:23731

Component Description

ABS006Q2

The crankshaft position sensor (POS) is located on the oil pan facing the gear teeth (cogs) of the signal plate. It detects the fluctuation of the engine revolution.

The sensor consists of a permanent magnet and Hall IC.

When the engine is running, the high and low parts of the teeth cause the gap with the sensor to change.

The changing gap causes the magnetic field near the sensor to change.

Due to the changing magnetic field, the voltage from the sensor changes.

The ECM receives the voltage signal and detects the fluctuation of the engine revolution.

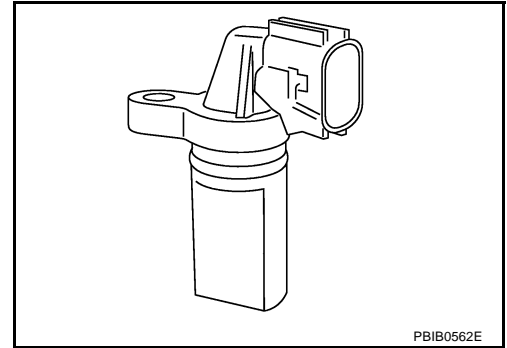

CONSULT-II Reference Value in Data Monitor Mode

ABS006Q3

Specification data are reference values.

MONITOR ITEM	CONDITION	SPECIFICATION
ENG SPEED	<ul style="list-style-type: none"> ● Run engine and compare CONSULT-II value with the tachometer indication. 	Almost the same speed as the tachometer indication.

On Board Diagnosis Logic

ABS006Q4

DTC No.	Trouble diagnosis name	DTC detecting condition	Possible cause
P0335 0335	Crankshaft position sensor (POS) circuit	<ul style="list-style-type: none"> ● The crankshaft position sensor (POS) signal is not detected by the ECM during the first few seconds of engine cranking. ● The proper pulse signal from the crankshaft position sensor (POS) is not sent to ECM while the engine is running. ● The crankshaft position sensor (POS) signal is not in the normal pattern during engine running. 	<ul style="list-style-type: none"> ● Harness or connectors (The sensor circuit is open or shorted) ● Crankshaft position sensor (POS) ● Signal plate

DTC Confirmation Procedure

ABS006Q5

NOTE:

If DTC Confirmation Procedure has been previously conducted, always turn ignition switch OFF and wait at least 10 seconds before conducting the next test.

TESTING CONDITION:

Before performing the following procedure, confirm that battery voltage is more than 10.5V with ignition switch ON.

WITH CONSULT-II

1. Turn ignition switch ON and select "DATA MONITOR" mode with CONSULT-II.
2. Crank engine for at least 2 seconds and run it for at least 5 seconds at idle speed.
3. If 1st trip DTC is detected, go to [EC-304, "Diagnostic Procedure"](#)

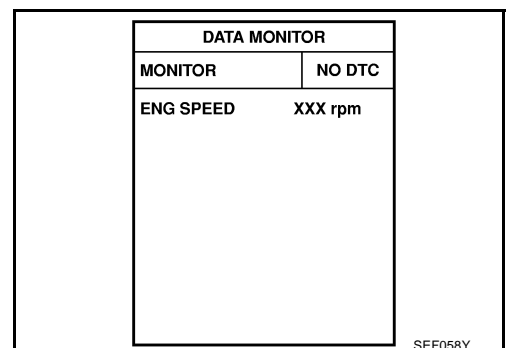

WITH GST

Follow the procedure "WITH CONSULT-II" above.

DTC P0335 CKP SENSOR (POS)

[VQ35DE]

Wiring Diagram

ABS006Q6

EC-POS-01

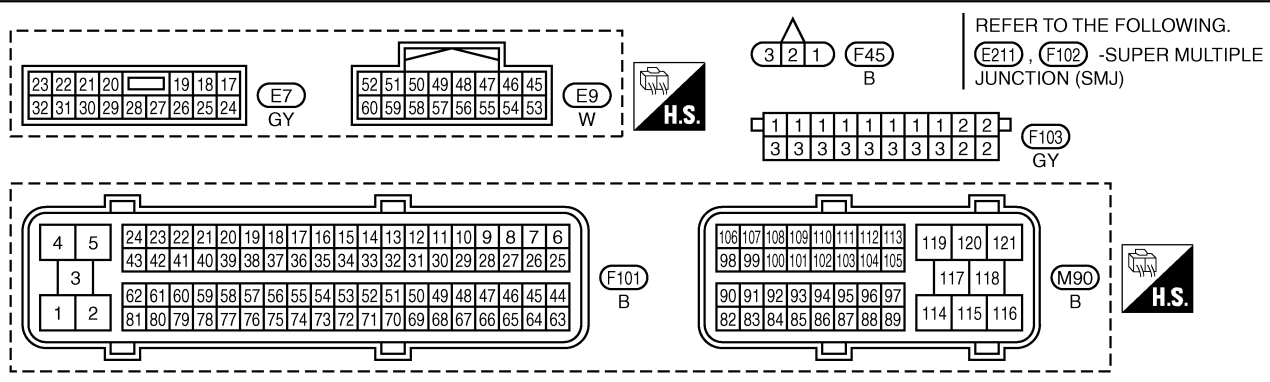
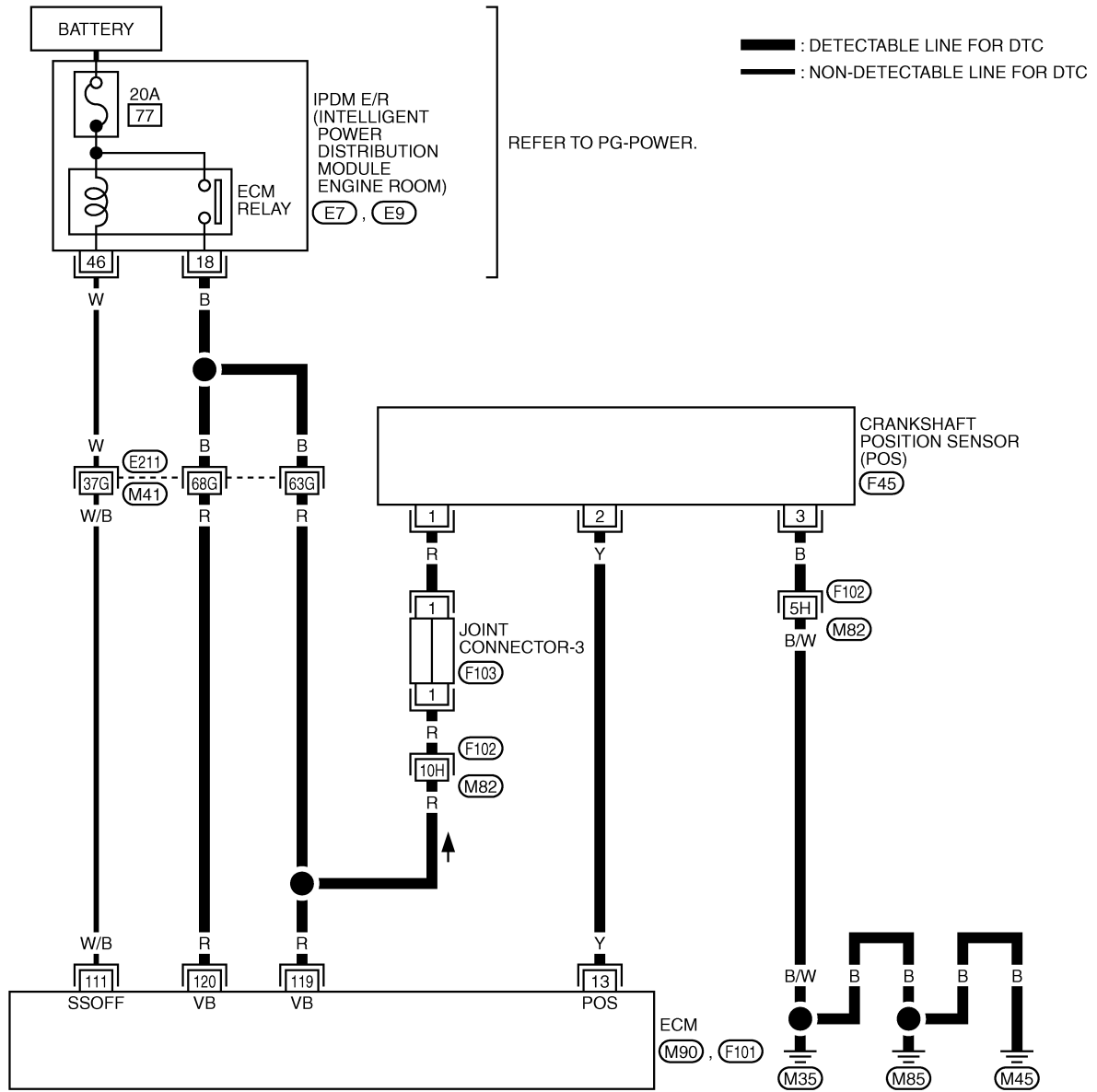

DTC P0335 CKP SENSOR (POS)

[VQ35DE]

Specification data are reference values and are measured between each terminal and ground.
Pulse signal is measured by CONSULT-II.

CAUTION:

Do not use ECM ground terminals when measuring input/output voltage. Doing so may result in damage to the ECM's transistor. Use a ground other than ECM terminals, such as the ground.

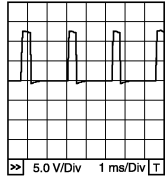
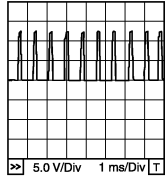
TER-MINAL NO.	WIRE COLOR	ITEM	CONDITION	DATA (DC Voltage)
13	Y	Crankshaft position sensor (POS)	<p>[Engine is running]</p> <ul style="list-style-type: none"> ● Warm-up condition ● Idle speed <p>NOTE: The pulse cycle changes depending on rpm at idle</p>	<p>Approximately 1.6V★</p>  <p>PBIB1041E</p>
			<p>[Engine is running]</p> <ul style="list-style-type: none"> ● Engine speed is 2,000 rpm 	<p>Approximately 1.4V★</p>  <p>PBIB1042E</p>

★: Average voltage for pulse signal (Actual pulse signal can be confirmed by oscilloscope.)

Diagnostic Procedure

ABS00CHF

1. CHECK GROUND CONNECTIONS

1. Turn ignition switch OFF.
2. Loosen and retighten ground three screws on the body. Refer to [EC-141, "Ground Inspection"](#).

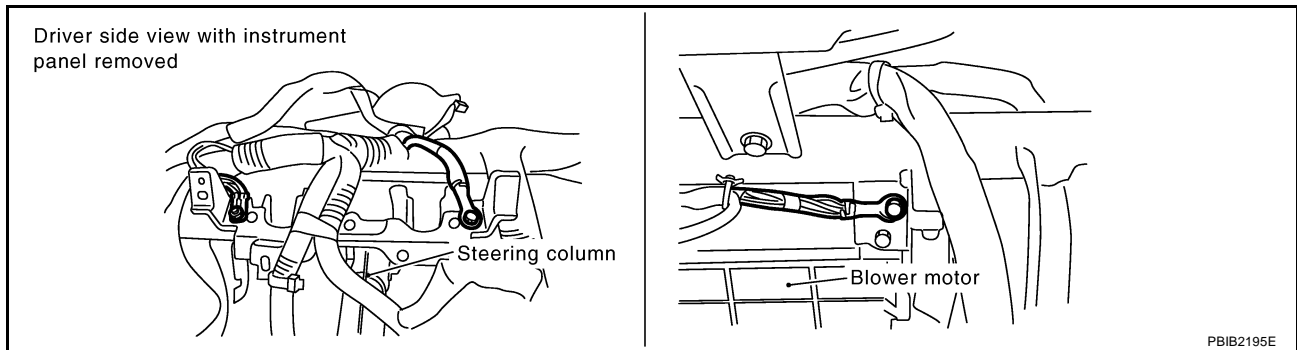

OK or NG

- OK >> GO TO 2.
- NG >> Repair or replace ground connections.

2. CHECK CRANKSHAFT POSITION (CKP) SENSOR (POS) POWER SUPPLY CIRCUIT

1. Disconnect crankshaft position (CKP) sensor (POS) harness connector.
2. Turn ignition switch ON.

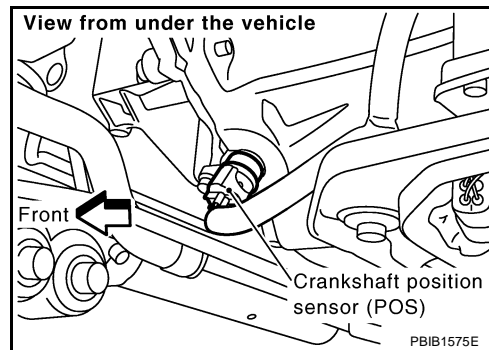

3. Check voltage between CKP sensor (POS) terminal 1 and ground with CONSULT-II or tester.

Voltage: Battery voltage

4. Also check harness for short to ground and short to power.

OK or NG

- OK >> GO TO 4.
NG >> GO TO 3.

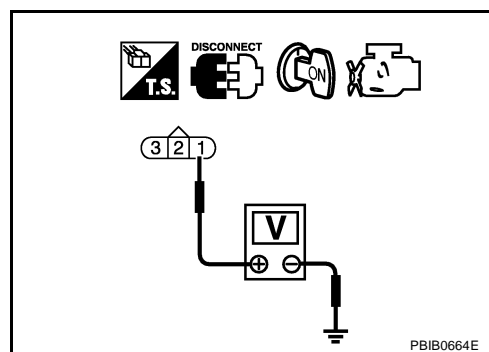

3. DETECT MALFUNCTIONING PART

Check the following.

- Harness connectors E211, M41
- Harness connectors F102, M82
- Joint connector-3
- Harness for open or short between crankshaft position sensor (POS) and ECM
- Harness for open or short between crankshaft position sensor (POS) and IPDM E/R

>> Repair open circuit or short to ground or short to power in harness or connectors.

4. CHECK CKP SENSOR (POS) GROUND CIRCUIT FOR OPEN AND SHORT

1. Turn ignition switch OFF.
2. Check harness continuity between CKP sensor (POS) terminal 3 and ground. Refer to Wiring Diagram.

Continuity should exist.

3. Also check harness for short to power.

OK or NG

- OK >> GO TO 6.
NG >> GO TO 5.

5. DETECT MALFUNCTIONING PART

Check the following.

- Harness connectors F102, M82
- Harness for open or short between crankshaft position sensor (POS) and ground

>> Repair open circuit or short to power in harness or connectors.

6. CHECK CKP SENSOR (POS) INPUT SIGNAL CIRCUIT FOR OPEN AND SHORT

1. Disconnect ECM harness connector.
2. Check harness continuity between ECM terminal 13 and CKP sensor (POS) terminal 2.
Refer to Wiring Diagram.

Continuity should exist.

3. Also check harness for short to ground and short to power.

OK or NG

OK >> GO TO 7.

NG >> Repair open circuit or short to ground or short to power in harness or connectors.

7. CHECK CRANKSHAFT POSITION SENSOR (POS)

Refer to [EC-307, "Component Inspection"](#) .

OK or NG

OK >> GO TO 8.

NG >> Replace crankshaft position sensor (POS).

8. CHECK GEAR TOOTH

Visually check for chipping signal plate gear tooth.

OK or NG

OK >> GO TO 9.

NG >> Replace the signal plate.

9. CHECK INTERMITTENT INCIDENT

Refer to [EC-135, "TROUBLE DIAGNOSIS FOR INTERMITTENT INCIDENT"](#) .

>> INSPECTION END

Component Inspection CRANKSHAFT POSITION SENSOR (POS)

1. Loosen the fixing bolt of the sensor.
2. Disconnect crankshaft position sensor (POS) harness connector.
3. Remove the sensor.
4. Visually check the sensor for chipping.

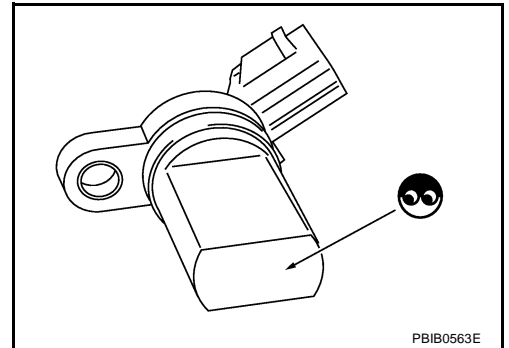

5. Check resistance as shown in the figure.

Terminal No. (Polarity)	Resistance Ω [at 25°C (77°F)]
1 (+) - 2 (-)	Except 0 or ∞
1 (+) - 3 (-)	
2 (+) - 3 (-)	

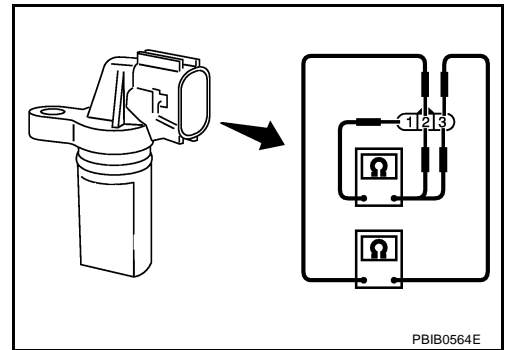

Removal and Installation CRANKSHAFT POSITION SENSOR (POS)

Refer to [AT-270, "COMPONENTS \(FOR VK45DE\)"](#) .

DTC P0340, P0345 CMP SENSOR (PHASE)

PFP:23731

Component Description

ABS006QA

The camshaft position sensor (PHASE) senses the retraction of intake valve camshaft to identify a particular cylinder. The camshaft position sensor (PHASE) senses the piston position.

When the crankshaft position sensor (POS) system becomes inoperative, the camshaft position sensor (PHASE) provides various controls of engine parts instead, utilizing timing of cylinder identification signals.

The sensor consists of a permanent magnet and Hall IC.

When engine is running, the high and low parts of the teeth cause the gap with the sensor to change.

The changing gap causes the magnetic field near the sensor to change.

Due to the changing magnetic field, the voltage from the sensor changes.

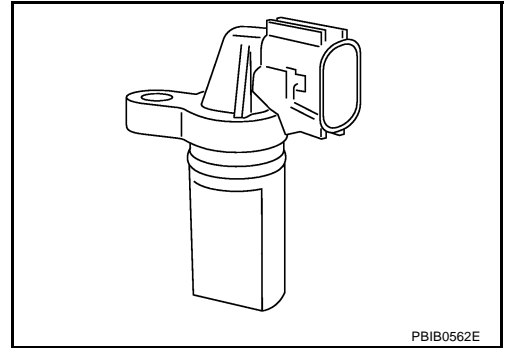

CONSULT-II Reference Value in Data Monitor Mode

ABS00CHG

Specification data are reference values.

MONITOR ITEM	CONDITION	SPECIFICATION
ENG SPEED	<ul style="list-style-type: none"> Run engine and compare CONSULT-II value with the tachometer indication. 	Almost the same speed as the tachometer indication.

On Board Diagnosis Logic

ABS006QB

DTC No.	Trouble diagnosis name	DTC detecting condition	Possible cause
P0340 0340 (Bank 1)	Camshaft position sensor (PHASE) circuit	<ul style="list-style-type: none"> The cylinder No. signal is not sent to ECM for the first few seconds during engine cranking. 	<ul style="list-style-type: none"> Harness or connectors (The sensor circuit is open or shorted) Camshaft position sensor (PHASE)
P0345 0345 (Bank 2)		<ul style="list-style-type: none"> The cylinder No. signal is not sent to ECM during engine running. The cylinder No. signal is not in the normal pattern during engine running. 	<ul style="list-style-type: none"> Camshaft (Intake) Starter motor (Refer to SC-10.) Starting system circuit (Refer to SC-10.) Dead (Weak) battery

DTC Confirmation Procedure

ABS006QC

NOTE:

If DTC Confirmation Procedure has been previously conducted, always turn ignition switch OFF and wait at least 10 seconds before conducting the next test.

TESTING CONDITION:

Before performing the following procedure, confirm that battery voltage is more than 10.5V with ignition switch ON.

WITH CONSULT-II

1. Turn ignition switch ON.
2. Select "DATA MONITOR" mode with CONSULT-II.
3. Crank engine for at least 2 seconds and run it for at least 5 seconds at idle speed.
4. If 1st trip DTC is detected, go to [EC-312, "Diagnostic Procedure"](#).
If 1st trip DTC is not detected, go to next step.
5. Maintaining engine speed at more than 800 rpm for at least 5 seconds.
6. If 1st trip DTC is detected, go to [EC-312, "Diagnostic Procedure"](#).

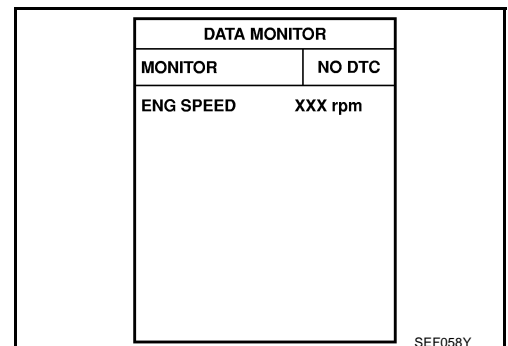

WITH GST

Follow the procedure "WITH CONSULT-II" above.

DTC P0340, P0345 CMP SENSOR (PHASE)

[VQ35DE]

ABS006QD

Wiring Diagram BANK 1

A
EC
C
D
E
F
G
H
I
J
K
L
M

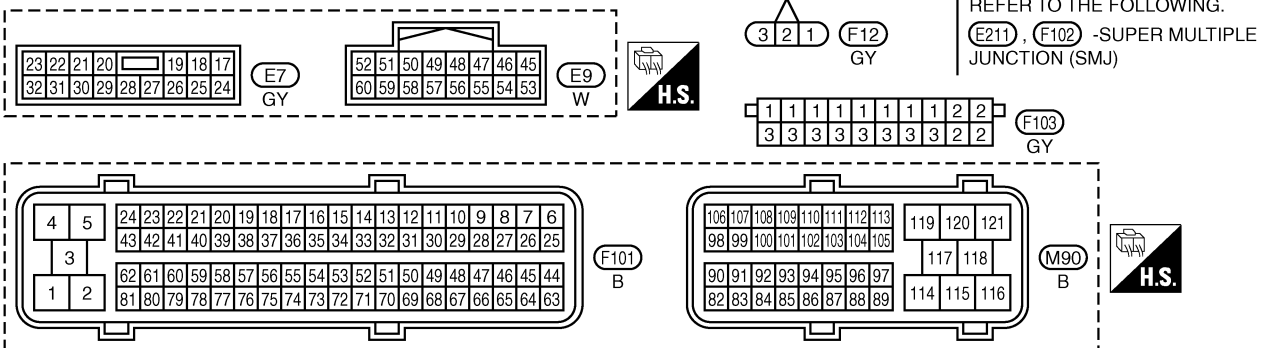
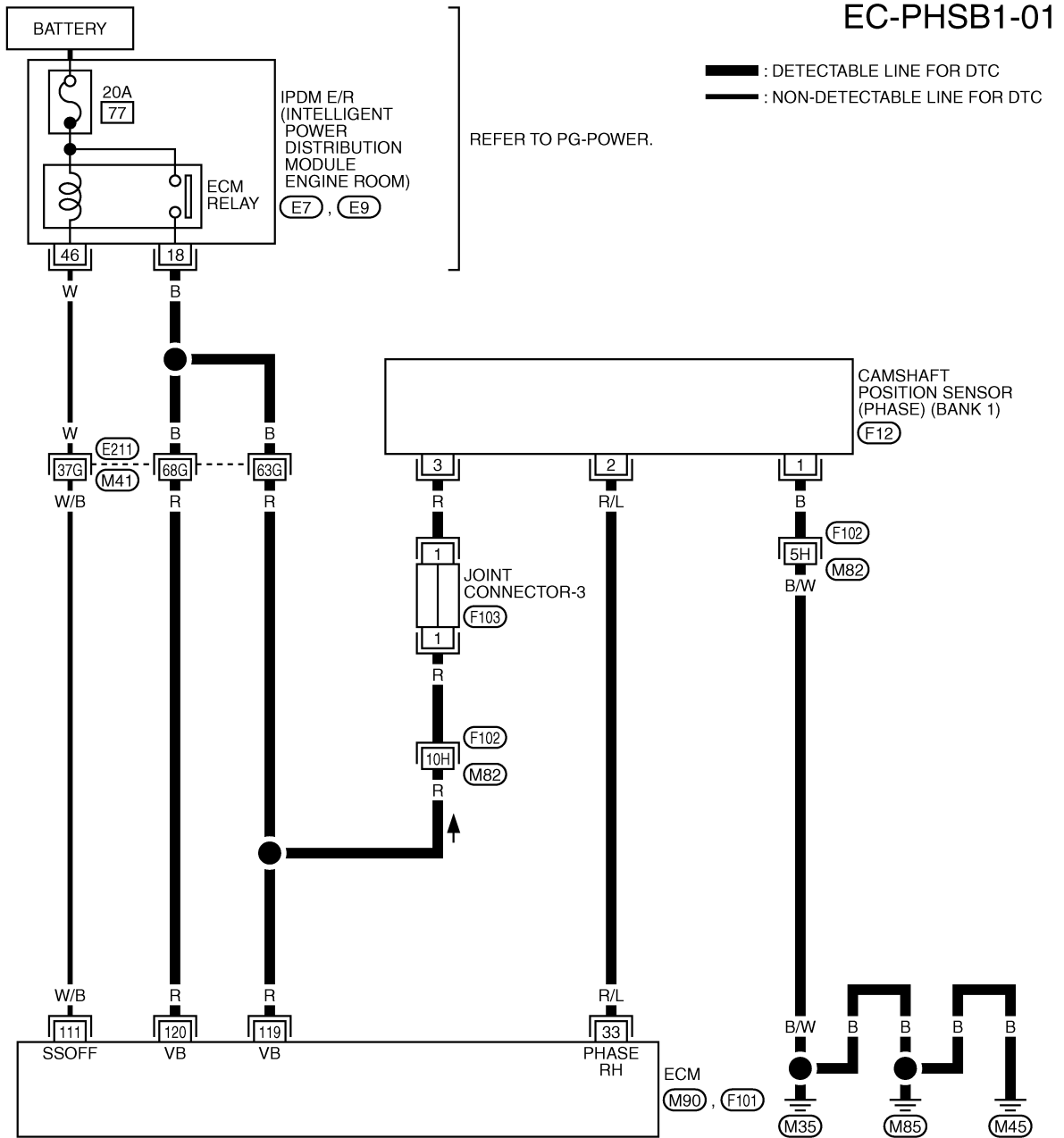

TBWM0298E

DTC P0340, P0345 CMP SENSOR (PHASE)

[VQ35DE]

Specification data are reference values and are measured between each terminal and ground.
Pulse signal is measured by CONSULT-II.

CAUTION:

Do not use ECM ground terminals when measuring input/output voltage. Doing so may result in damage to the ECM's transistor. Use a ground other than ECM terminals, such as the ground.

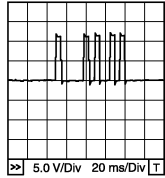
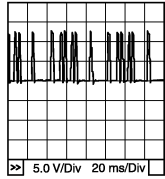
TER-MINAL NO.	WIRE COLOR	ITEM	CONDITION	DATA (DC Voltage)
33	R/L	Camshaft position sensor (PHASE) (bank 1)	<p>[Engine is running]</p> <ul style="list-style-type: none"> ● Warm-up condition ● Idle speed <p>NOTE: The pulse cycle changes depending on rpm at idle</p>	<p>1.0 - 4.0V★</p>  <p>PBIB1039E</p>
			<p>[Engine is running]</p> <ul style="list-style-type: none"> ● Engine speed is 2,000 rpm 	<p>1.0 - 4.0V★</p>  <p>PBIB1040E</p>

★: Average voltage for pulse signal (Actual pulse signal can be confirmed by oscilloscope.)

DTC P0340, P0345 CMP SENSOR (PHASE)

[VQ35DE]

BANK 2

EC-PHSB2-01

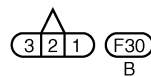
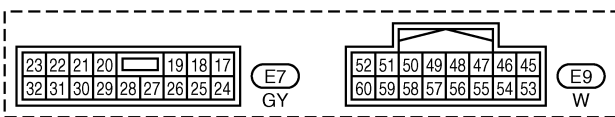
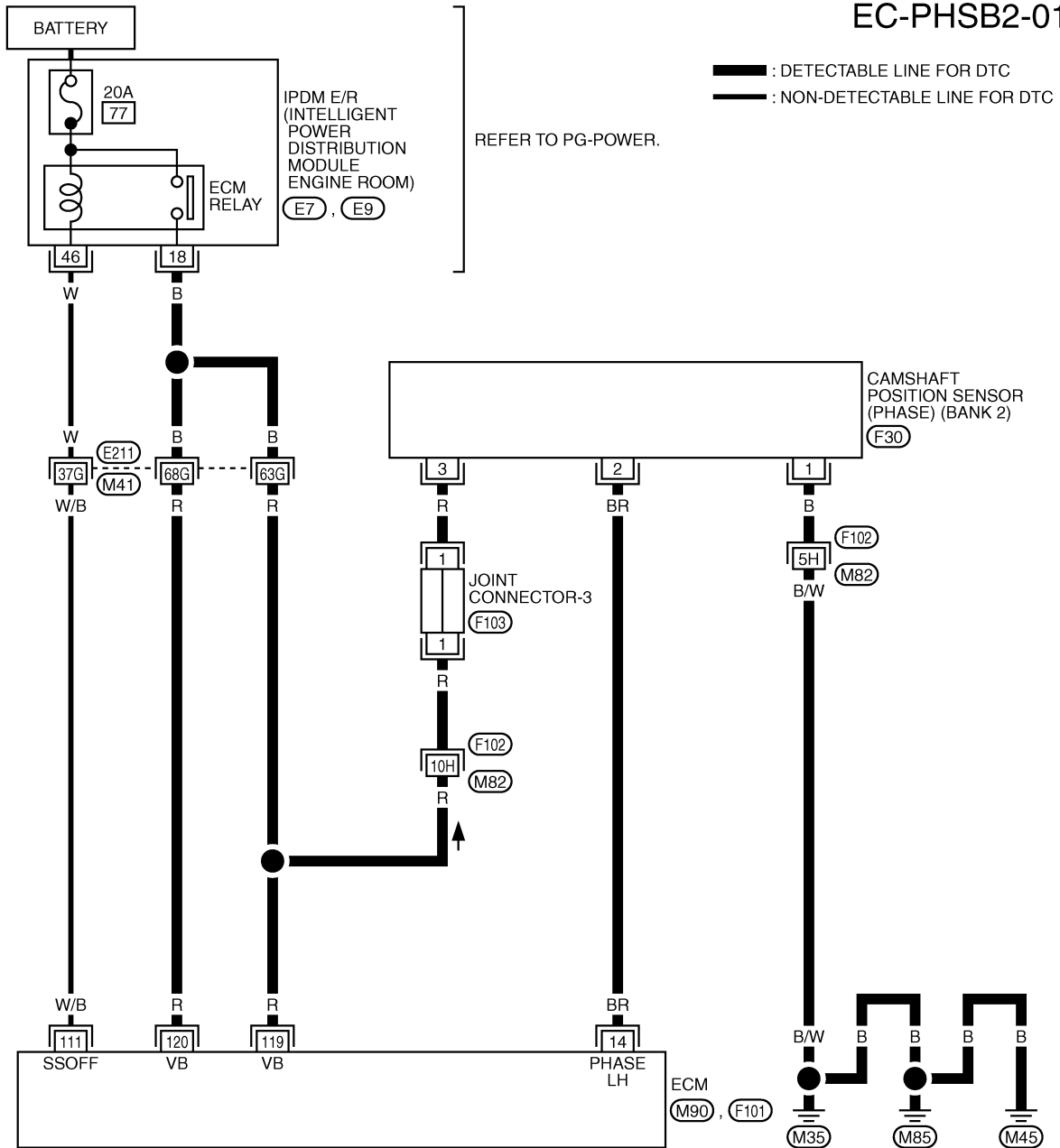

REFER TO THE FOLLOWING.
 (E211), (F102) -SUPER MULTIPLE JUNCTION (SMJ)

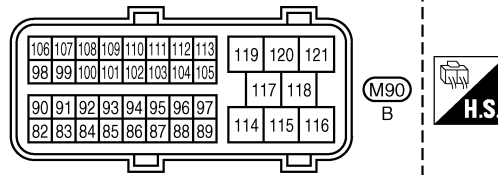
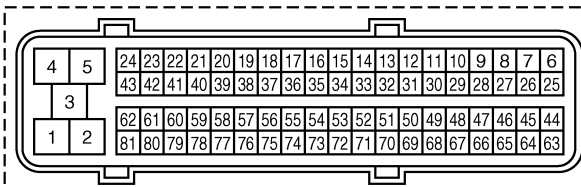
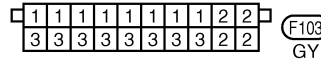

TBWM0299E

DTC P0340, P0345 CMP SENSOR (PHASE)

[VQ35DE]

Specification data are reference values and are measured between each terminal and ground.
Pulse signal is measured by CONSULT-II.

CAUTION:

Do not use ECM ground terminals when measuring input/output voltage. Doing so may result in damage to the ECM's transistor. Use a ground other than ECM terminals, such as the ground.

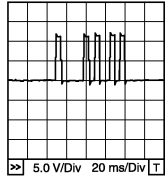
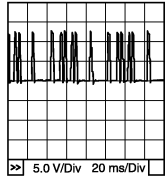
TER-MINAL NO.	WIRE COLOR	ITEM	CONDITION	DATA (DC Voltage)
14	BR	Camshaft position sensor (PHASE) (bank 2)	<p>[Engine is running]</p> <ul style="list-style-type: none"> ● Warm-up condition ● Idle speed <p>NOTE: The pulse cycle changes depending on rpm at idle</p>	<p>1.0 - 4.0V★</p>  <p>PBIB1039E</p>
			<p>[Engine is running]</p> <ul style="list-style-type: none"> ● Engine speed is 2,000 rpm 	<p>1.0 - 4.0V★</p>  <p>PBIB1040E</p>

★: Average voltage for pulse signal (Actual pulse signal can be confirmed by oscilloscope.)

Diagnostic Procedure

ABS00CHH

1. CHECK STARTING SYSTEM

Turn ignition switch to START position.

Does the engine turn over?

Does the starter motor operate?

Yes or No

Yes >> GO TO 2.

No >> Check starting system. (Refer to [SC-10, "STARTING SYSTEM"](#) .)

2. CHECK GROUND CONNECTIONS

1. Turn ignition switch OFF.
2. Loosen and retighten ground three screws on the body. Refer to [EC-141, "Ground Inspection"](#) .

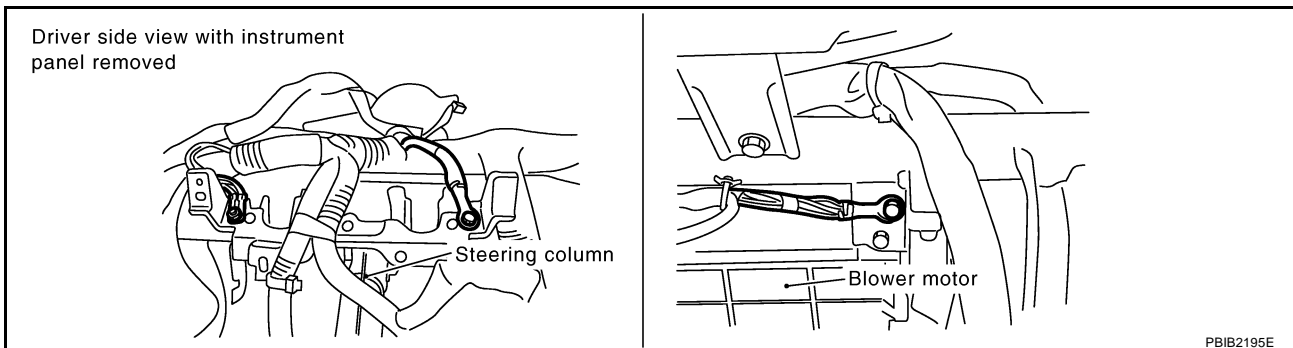

OK or NG

OK >> GO TO 3.

NG >> Repair or replace ground connections.

3. CHECK CAMSHAFT POSITION (CMP) SENSOR (PHASE) POWER SUPPLY CIRCUIT

1. Disconnect camshaft position (CMP) sensor (PHASE) harness connector.

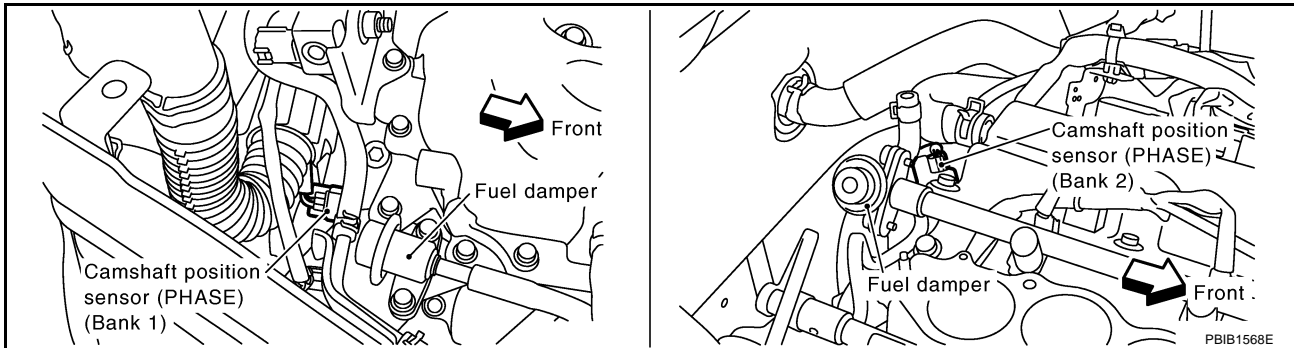

2. Turn ignition switch ON.
3. Check voltage between CMP sensor (PHASE) terminal 3 and ground with CONSULT-II or tester.

Voltage: Battery voltage

4. Also check harness for short to ground and short to power.

OK or NG

- OK >> GO TO 5.
NG >> GO TO 4.

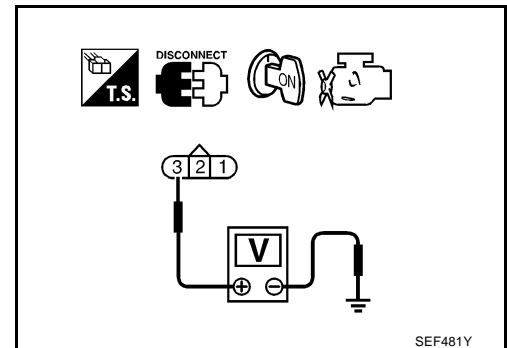

4. DETECT MALFUNCTIONING PART

Check the following.

- Harness connectors E211, M41
- Harness connectors F102, M82
- Joint connector-3
- Harness for open or short between camshaft position sensor (PHASE) and ECM
- Harness for open or short between camshaft position sensor (PHASE) and IPDM E/R

>> Repair open circuit or short to ground or short to power in harness or connectors.

5. CHECK CMP SENSOR (PHASE) GROUND CIRCUIT FOR OPEN AND SHORT

1. Turn ignition switch OFF.
2. Check harness continuity between CMP sensor (PHASE) terminal 1 and ground.

Continuity should exist.

3. Also check harness for short to power.

OK or NG

- OK >> GO TO 7.
NG >> GO TO 6.

6. DETECT MALFUNCTIONING PART

Check the following.

- Harness connectors F102, M82
- Harness for open or short between CMP sensor (PHASE) and ground

>> Repair open circuit or short to power in harness or connectors.

7. CHECK CMP SENSOR (PHASE) INPUT SIGNAL CIRCUIT FOR OPEN AND SHORT

1. Disconnect ECM harness connector.
2. Check harness continuity between ECM terminal 33 or 14 and CMP sensor (PHASE) terminal 2.
Refer to Wiring Diagram.

Continuity should exist.

3. Also check harness for short to ground and short to power.

OK or NG

OK >> GO TO 8.

NG >> Repair open circuit or short to ground or short to power in harness or connectors.

8. CHECK CAMSHAFT POSITION SENSOR (PHASE)

Refer to [EC-315, "Component Inspection"](#) .

OK or NG

OK >> GO TO 9.

NG >> Replace camshaft position sensor (PHASE).

9. CHECK CAMSHAFT (INTAKE)

Check the following.

- Accumulation of debris to the signal plate of camshaft rear end
- Chipping signal plate of camshaft rear end

OK or NG

OK >> GO TO 10.

NG >> Remove debris and clean the signal plate of camshaft rear end or replace camshaft.

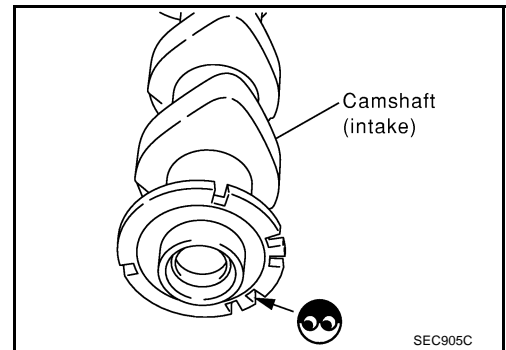

10. CHECK INTERMITTENT INCIDENT

Refer to [EC-135, "TROUBLE DIAGNOSIS FOR INTERMITTENT INCIDENT"](#) .

>> **INSPECTION END**

A
EC
C
D
E
F
G
H
I
J
K
L
M

Component Inspection
CAMSHAFT POSITION SENSOR (PHASE)

1. Loosen the fixing bolt of the sensor.
2. Disconnect camshaft position sensor (PHASE) harness connector.
3. Remove the sensor.
4. Visually check the sensor for chipping.

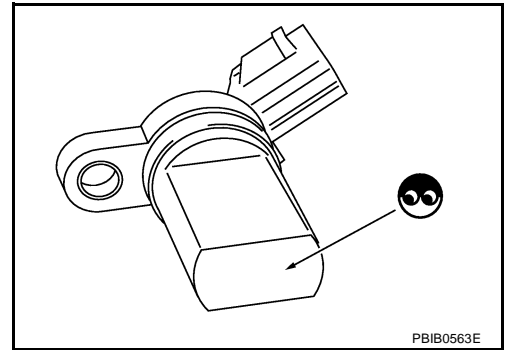

5. Check resistance as shown in the figure.

Terminal No. (Polarity)	Resistance Ω [at 25°C (77°F)]
1 (+) - 2 (-)	Except 0 or ∞
1 (+) - 3 (-)	
2 (+) - 3 (-)	

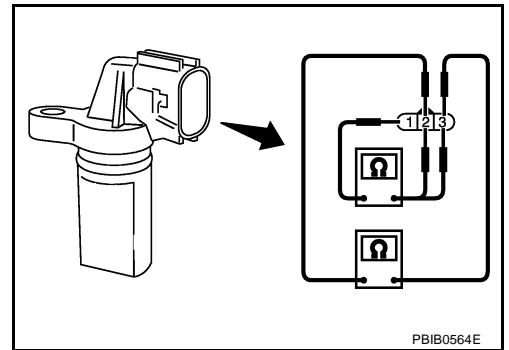

Removal and Installation
CAMSHAFT POSITION SENSOR (PHASE)

Refer to [EM-82, "CAMSHAFT"](#) .

DTC P0420, P0430 THREE WAY CATALYST FUNCTION

PFP:20905

On Board Diagnosis Logic

ABS006QH

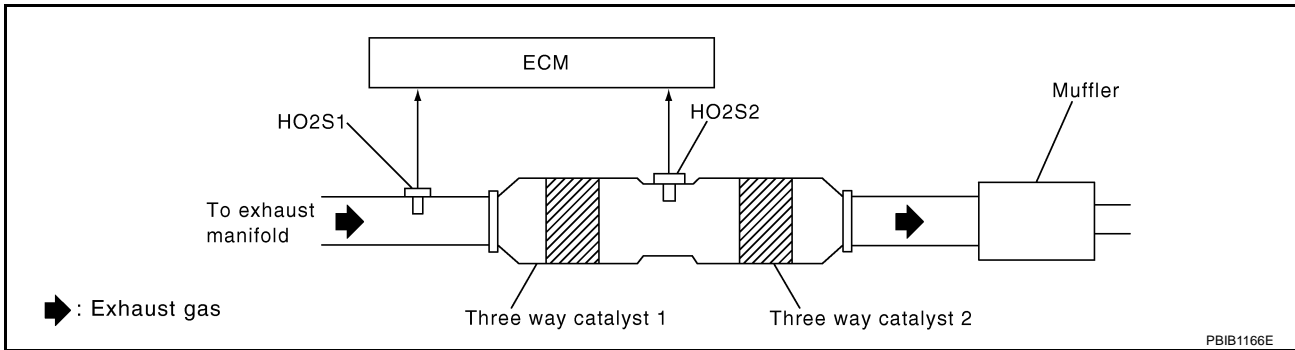

The ECM monitors the switching frequency ratio of heated oxygen sensors 1 and 2.

A three way catalyst 1 with high oxygen storage capacity will indicate a low switching frequency of heated oxygen sensor 2. As oxygen storage capacity decreases, the heated oxygen sensor 2 switching frequency will increase.

When the frequency ratio of heated oxygen sensors 1 and 2 approaches a specified limit value, the three way catalyst 1 malfunction is diagnosed.

DTC No.	Trouble diagnosis name	DTC detecting condition	Possible cause
P0420 0420 (Bank 1)	Catalyst system efficiency below threshold	<ul style="list-style-type: none"> ● Three way catalyst 1 does not operate properly. ● Three way catalyst 1 does not have enough oxygen storage capacity. 	<ul style="list-style-type: none"> ● Three way catalyst 1 ● Exhaust tube ● Intake air leaks ● Fuel injector ● Fuel injector leaks ● Spark plug ● Improper ignition timing
P0430 0430 (Bank 2)			

DTC Confirmation Procedure

ABS006QI

NOTE:

If DTC Confirmation Procedure has been previously conducted, always turn ignition switch OFF and wait at least 10 seconds before conducting the next test.

WITH CONSULT-II

TESTING CONDITION:

Do not hold engine speed for more than the specified minutes below.

1. Turn ignition switch ON and select "DATA MONITOR" mode with CONSULT-II.
2. Start engine and warm it up to the normal operating temperature.
3. Turn ignition switch OFF and wait at least 10 seconds.
4. Start engine and keep the engine speed between 3,500 and 4,000 rpm for at least 1 minute under no load.
5. Let engine idle for 1 minute.
6. Make sure that "COOLAN TEMP/S" indicates more than 70°C (158°F).
If not, warm up engine and go to next step when "COOLAN TEMP/S" indication reaches to 70°C (158°F).
7. Open engine hood.

DATA MONITOR	
MONITOR	NO DTC
ENG SPEED	XXX rpm
COOLAN TEMP/S	XXX °C
VHCL SPEED SE	XXX km/h
B/FUEL SCHDL	XXX msec

SEF189Y

DTC P0420, P0430 THREE WAY CATALYST FUNCTION

[VQ35DE]

8. Select "DTC & SRT CONFIRMATION" then "SRT WORK SUPPORT" mode with CONSULT-II.
9. Rev engine up to 2,000 to 3,000 rpm and hold it for 3 consecutive minutes then release the accelerator pedal completely. If "INCMP" of "CATALYST" changed to "CMPLT", go to step 12.
10. Wait 5 seconds at idle.

SRT WORK SUPPORT	
CATALYST	INCMP
EVAP SYSTEM	INCMP
HO2S HTR	CMPLT
HO2S	INCMP
MONITOR	
ENG SPEED	XXX rpm
MAS A/F SE-B1	XXX V
B/FUEL SCHDL	XXX msec
A/F ALPHA-B1	XXX V
COOLAN TEMP/S	XX °C
HO2S1 (B1)	XXX V

SEF940Z

11. Rev engine up to 2,000 to 3,000 rpm and maintain it until "INCMP" of "CATALYST" changes to "CMPLT" (It will take approximately 5 minutes). If not "CMPLT", stop engine and cool it down to less than 70°C (158°F) and then retest from step 1.

SRT WORK SUPPORT	
CATALYST	CMPLT
EVAP SYSTEM	INCMP
HO2S HTR	CMPLT
HO2S	INCMP
MONITOR	
ENG SPEED	XXX rpm
MAS A/F SE-B1	XXX V
B/FUEL SCHDL	XXX msec
A/F ALPHA-B1	XXX V
COOLAN TEMP/S	XX °C
HO2S1 (B1)	XXX V

SEF941Z

12. Select "SELF-DIAG RESULTS" mode with CONSULT-II.
13. Confirm that the 1st trip DTC is not detected. If the 1st trip DTC is detected, go to [EC-318, "Diagnostic Procedure"](#).

SELF DIAG RESULTS	
DTC RESULTS	TIME
NO DTC IS DETECTED. FURTHER TESTING MAY BE REQUIRED.	

SEF535Z

Overall Function Check

ABS006QJ

Use this procedure to check the overall function of the three way catalyst 1. During this check, a DTC might not be confirmed.

WITH GST

1. Turn ignition switch OFF and wait at least 10 seconds.
2. Start engine and keep the engine speed between 3,500 and 4,000 rpm for at least 1 minute under no load.
3. Let engine idle for 1 minute.
4. Open engine hood.
5. Set voltmeters probes between ECM terminals 35 [HO2S1 (bank 1) signal], 16 [HO2S1 (bank 2) signal] and ground, and ECM terminals 74 [HO2S2 (bank 1) signal], 55 [HO2S2 (bank 2) signal] and ground.
6. Keep engine speed at 2,000 rpm constant under no load.

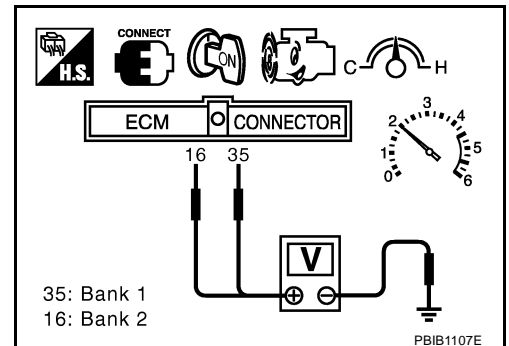

DTC P0420, P0430 THREE WAY CATALYST FUNCTION

[VQ35DE]

7. Make sure that the voltage switching frequency (high & low) between ECM terminals 74 and ground, or 55 and ground is very less than that of ECM terminals 35 and ground, or 16 and ground.

Switching frequency ratio = A/B

A: Heated oxygen sensor 2 voltage switching frequency

B: Heated oxygen sensor 1 voltage switching frequency

This ratio should be less than 0.75.

If the ratio is greater than above, it means three way catalyst 1 does not operate properly. Go to [EC-318. "Diagnostic Procedure"](#).

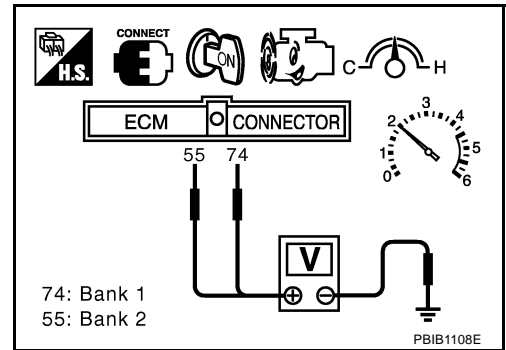

NOTE:

If the voltage at terminal 35 or 16 does not switch periodically more than 5 times within 10 seconds at step 7, perform trouble diagnosis for DTC P0133, P0153 first. (See [EC-214](#).)

Diagnostic Procedure

ABS006QK

1. CHECK EXHAUST SYSTEM

Visually check exhaust tubes and muffler for dent.

OK or NG

OK >> GO TO 2.

NG >> Repair or replace.

2. CHECK EXHAUST GAS LEAK

1. Start engine and run it at idle.
2. Listen for an exhaust gas leak before the three way catalyst 1.

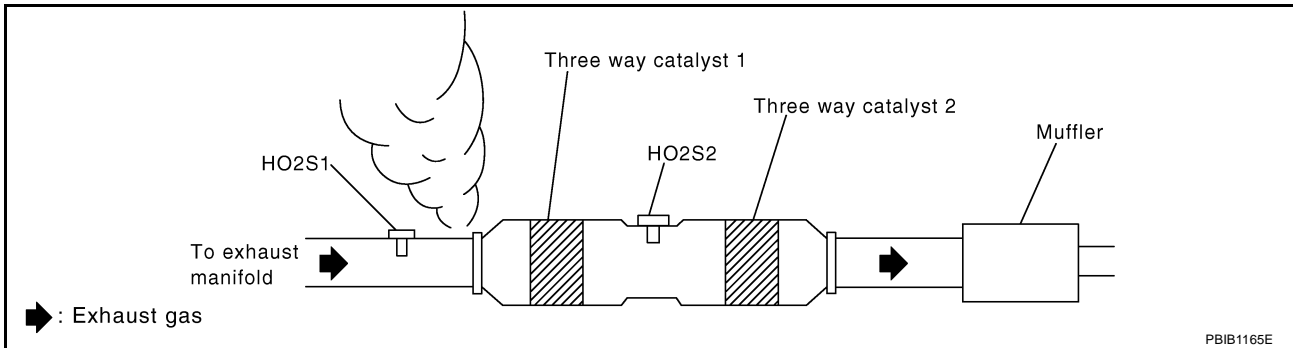

OK or NG

OK >> GO TO 3.

NG >> Repair or replace.

3. CHECK INTAKE AIR LEAK

Listen for an intake air leak after the mass air flow sensor.

OK or NG

OK >> GO TO 4.

NG >> Repair or replace.

4. CHECK IGNITION TIMING

Check the following items. Refer to [EC-83, "Basic Inspection"](#) .

Items	Specifications
Target idle speed	650 ± 50 rpm (in P or N position)
Ignition timing	15 ± 5° BTDC (in P or N position)

OK or NG

- OK >> GO TO 5.
- NG >> Follow the [EC-83, "Basic Inspection"](#) .

5. CHECK INJECTORS

1. Stop engine and then turn ignition switch ON.
2. Check voltage between ECM terminals 21, 22, 23, 40, 41, 42 and ground with CONSULT-II or tester.
Refer to Wiring Diagram for Injectors, [EC-598](#) .

Battery voltage should exist.

OK or NG

- OK >> GO TO 6.
- NG >> Perform [EC-599, "Diagnostic Procedure"](#) .

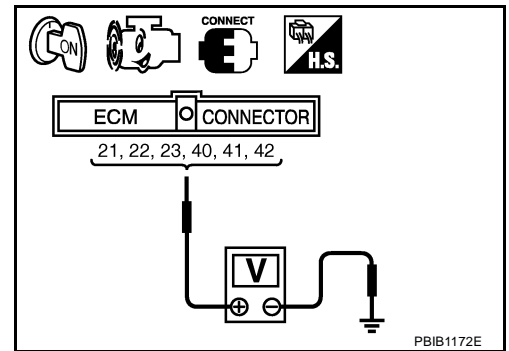

6. CHECK IGNITION SPARK

1. Turn ignition switch OFF.
2. Disconnect ignition coil assembly from rocker cover.
3. Connect a known-good spark plug to the ignition coil assembly.
4. Disconnect all injector harness connectors.
5. Place end of spark plug against a suitable ground and crank engine.
6. Check for spark.

OK or NG

- OK >> GO TO 7.
- NG >> Check ignition coil with power transistor and their circuit.
Refer to [EC-585, "IGNITION SIGNAL"](#) .

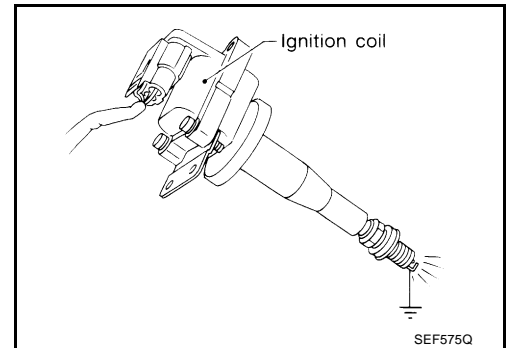

7. CHECK FUEL INJECTOR

1. Turn ignition switch OFF.
2. Remove injector assembly.
Refer to [EM-45, "FUEL INJECTOR AND FUEL TUBE"](#) .
Keep fuel hose and all injectors connected to injector gallery.
3. Disconnect all ignition coil harness connectors.
4. Turn ignition switch ON.
Make sure fuel does not drip from injector.

OK or NG

OK (Does not drip.)>>GO TO 8.

NG (Drips.)>>Replace the injector(s) from which fuel is dripping.

8. CHECK INTERMITTENT INCIDENT

Refer to [EC-135, "TROUBLE DIAGNOSIS FOR INTERMITTENT INCIDENT"](#) .

Trouble is fixed.>>**INSPECTION END**

Trouble is not fixed.>>Replace three way catalyst assembly.

DTC P0441 EVAP CONTROL SYSTEM

PFP:14950

System Description

ABS006QL

NOTE:

If DTC P0441 is displayed with other DTC such as P2122, P2123, P2127, P2128 or P2138, first perform trouble diagnosis for other DTC.

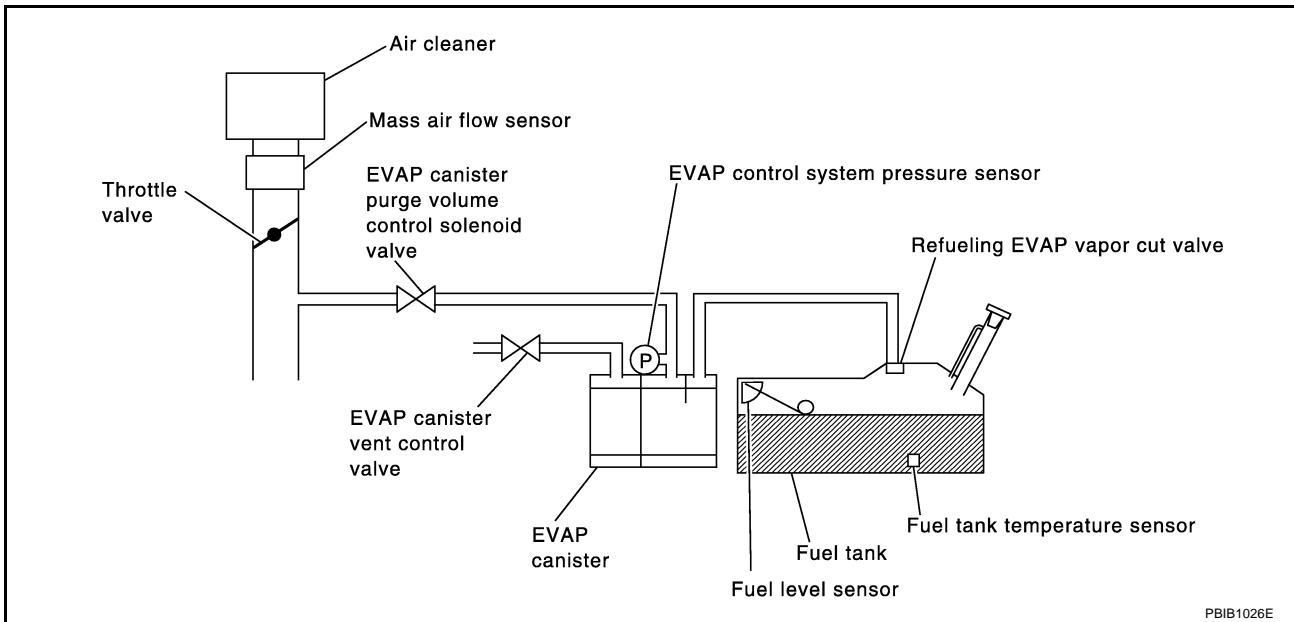

In this evaporative emission (EVAP) control system, purge flow occurs during non-closed throttle conditions. Purge volume is related to air intake volume. Under normal purge conditions (non-closed throttle), the EVAP canister purge volume control solenoid valve is open to admit purge flow. Purge flow exposes the EVAP control system pressure sensor to intake manifold vacuum.

On Board Diagnosis Logic

ABS006QM

Under normal conditions (non-closed throttle), sensor output voltage indicates if pressure drop and purge flow are adequate. If not, a malfunction is determined.

DTC No.	Trouble diagnosis name	DTC detecting condition	Possible cause
P0441 0441	EVAP control system incorrect purge flow	EVAP control system does not operate properly, EVAP control system has a leak between intake manifold and EVAP control system pressure sensor.	<ul style="list-style-type: none"> ● EVAP canister purge volume control solenoid valve stuck closed ● EVAP control system pressure sensor and the circuit ● Loose, disconnected or improper connection of rubber tube ● Blocked rubber tube ● Cracked EVAP canister ● EVAP canister purge volume control solenoid valve circuit ● Accelerator pedal position sensor ● Blocked purge port ● EVAP canister vent control valve

DTC Confirmation Procedure

ABS006QN

CAUTION:

Always drive vehicle at a safe speed.

NOTE:

If DTC Confirmation Procedure has been previously conducted, always turn ignition switch OFF and wait at least 10 seconds before conducting the next test.

TESTING CONDITION:

DTC P0441 EVAP CONTROL SYSTEM

[VQ35DE]

Always perform test at a temperature of 5°C (41°F) or more.

WITH CONSULT-II

1. Start engine and warm it up to normal operating temperature.
2. Turn ignition switch OFF and wait at least 10 seconds.
3. Start engine and let it idle for at least 70 seconds.
4. Select "PURG FLOW P0441" of "EVAPORATIVE SYSTEM" in "DTC CONFIRMATION" mode with CONSULT-II.
5. Touch "START".
If "COMPLETED" is displayed, go to step 7.
6. When the following conditions are met, "TESTING" will be displayed on the CONSULT-II screen. Maintain the conditions continuously until "TESTING" changes to "COMPLETED". (It will take at least 35 seconds.)

Selector lever	Suitable position
Vehicle speed	32 - 120 km/h (20 - 75 MPH)
ENG SPEED	500 - 3,000 rpm
B/FUEL SCHDL	1.3 - 9.0 msec
Engine coolant temperature	70 - 100°C (158 - 212°F)

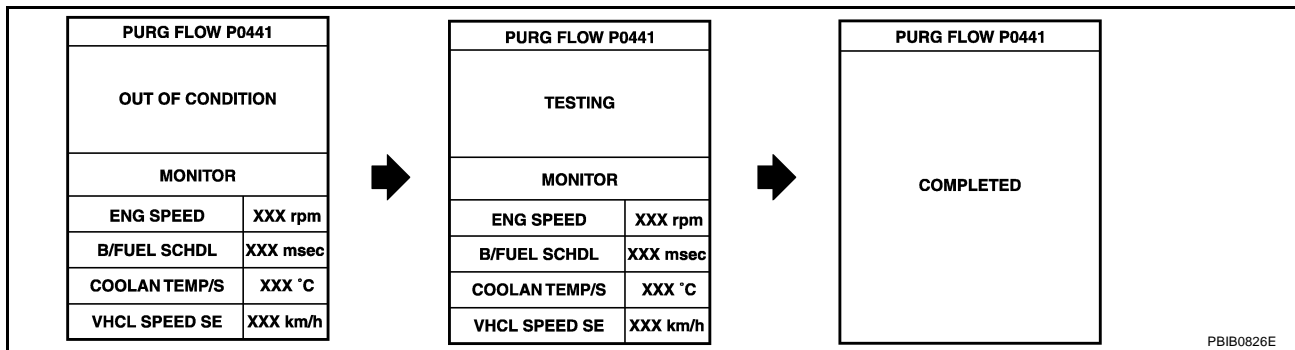

If "TESTING" is not changed for a long time, retry from step 2.

7. Make sure that "OK" is displayed after touching "SELF-DIAG RESULTS". If "NG" is displayed, refer to [EC-323, "Diagnostic Procedure"](#).

Overall Function Check

ABS006Q0

Use this procedure to check the overall monitoring function of the EVAP control system purge flow monitoring. During this check, a 1st trip DTC might not be confirmed.

WITH GST

1. Lift up drive wheels.
2. Start engine (TCS switch or VDC switch OFF) and warm it up to normal operating temperature.
3. Turn ignition switch OFF, wait at least 10 seconds.
4. Start engine and wait at least 70 seconds.
5. Set voltmeter probes to ECM terminals 32 (EVAP control system pressure sensor signal) and ground.
6. Check EVAP control system pressure sensor value at idle speed and note it.
7. Establish and maintain the following conditions for at least 1 minute.

Air conditioner switch	ON
Headlamp switch	ON
Rear window defogger switch	ON
Engine speed	Approx. 3,000 rpm
Gear position	Any position other than P, N or R

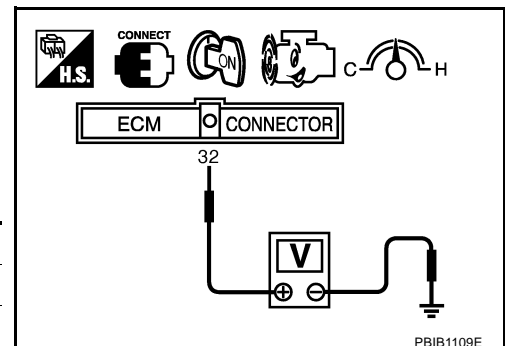

8. Verify that EVAP control system pressure sensor value stays 0.1V less than the value at idle speed (measured at step 6) for at least 1 second.
9. If NG, go to [EC-323, "Diagnostic Procedure"](#) .

Diagnostic Procedure

ABS006QP

1. CHECK EVAP CANISTER

1. Turn ignition switch OFF.
2. Check EVAP canister for cracks.

OK or NG

- OK (With CONSULT-II)>>GO TO 2.
- OK (Without CONSULT-II)>>GO TO 3.
- NG >> Replace EVAP canister.

2. CHECK PURGE FLOW

 **With CONSULT-II**

1. Disconnect vacuum hose connected to EVAP canister purge volume control solenoid valve at EVAP service port and install vacuum gauge. For the location of EVAP service port, refer to [EC-644, "EVAPORATIVE EMISSION LINE DRAWING"](#) .
2. Start engine and let it idle.
3. Select "PURG VOL CONT/V" in "ACTIVE TEST" mode with CONSULT-II.
4. Rev engine up to 2,000 rpm.
5. Touch "Qd" and "Qu" on CONSULT-II screen to adjust "PURG VOL CONT/V" opening and check vacuum existence.

PURG VOL CONT/V	Vacuum
100%	Should exist.
0%	Should not exist.

OK or NG

- OK >> GO TO 7.
- NG >> GO TO 4.

ACTIVE TEST	
PURG VOL CONT/V	0 %
MONITOR	
ENG SPEED	XXX rpm
HO2S1 MNTR (B1)	LEAN
HO2S1 MNTR (B2)	LEAN
A/F ALPHA-B1	XXX %
A/F ALPHA-B2	XXX %

PBIB0147E

3. CHECK PURGE FLOW

 **Without CONSULT-II**

1. Start engine and warm it up to normal operating temperature.
2. Stop engine.
3. Disconnect vacuum hose connected to EVAP canister purge volume control solenoid valve at EVAP service port and install vacuum gauge. For the location of EVAP service port, refer to [EC-644, "EVAPORATIVE EMISSION LINE DRAWING"](#) .
4. Start engine and let it idle for at least 80 seconds.
5. Check vacuum gauge indication when revving engine up to 2,000 rpm.

Vacuum should exist.

6. Release the accelerator pedal fully and let idle.

Vacuum should not exist.

OK or NG

- OK >> GO TO 7.
- NG >> GO TO 4.

4. CHECK EVAP PURGE LINE

1. Turn ignition switch OFF.
2. Check EVAP purge line for improper connection or disconnection.
Refer to [EC-644, "EVAPORATIVE EMISSION LINE DRAWING"](#) .

OK or NG

- OK >> GO TO 5.
NG >> Repair it.

5. CHECK EVAP PURGE HOSE AND PURGE PORT

1. Disconnect purge hoses connected to EVAP service port **A** and EVAP canister purge volume control solenoid valve **B** .
2. Blow air into each hose and EVAP purge port **C** .

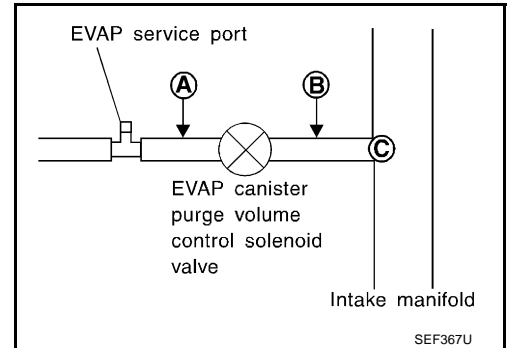

3. Check that air flows freely.

OK or NG

- OK (With CONSULT-II)>>GO TO 6.
OK (Without CONSULT-II)>>GO TO 7.
NG >> Repair or clean hoses and/or purge port.

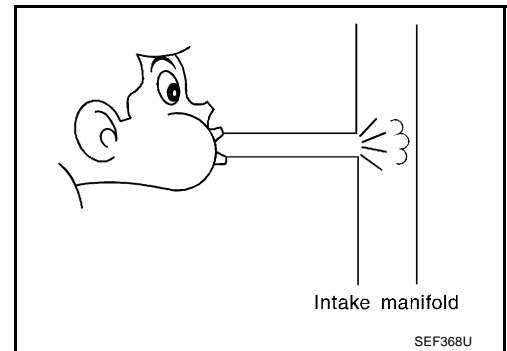

6. CHECK EVAP CANISTER PURGE VOLUME CONTROL SOLENOID VALVE

With CONSULT-II

1. Start engine.
2. Perform "PURG VOL CONT/V" in "ACTIVE TEST" mode with CONSULT-II. Check that engine speed varies according to the valve opening.

OK or NG

- OK >> GO TO 8.
NG >> GO TO 7.

ACTIVE TEST	
PURG VOL CONT/V	0 %
MONITOR	
ENG SPEED	XXX rpm
HO2S1 MNTR (B1)	LEAN
HO2S1 MNTR (B2)	LEAN
A/F ALPHA-B1	XXX %
A/F ALPHA-B2	XXX %

7. CHECK EVAP CANISTER PURGE VOLUME CONTROL SOLENOID VALVE

Refer to [EC-340, "Component Inspection"](#) .

OK or NG

- OK >> GO TO 8.
NG >> Replace EVAP canister purge volume control solenoid valve.

8. CHECK EVAP CONTROL SYSTEM PRESSURE SENSOR CONNECTOR

A

1. Disconnect EVAP control system pressure sensor harness connector.
2. Check connectors for water.

Water should not exist.

EC

OK or NG

- OK >> GO TO 9.
NG >> Replace EVAP control system pressure sensor.

C

9. CHECK EVAP CONTROL SYSTEM PRESSURE SENSOR FUNCTION

D

Refer to DTC Confirmation Procedure for DTC P0452 [EC-352](#) , P0453 [EC-358](#) .

OK or NG

- OK >> GO TO 10.
NG >> Replace EVAP control system pressure sensor.

E

10. CHECK RUBBER TUBE FOR CLOGGING

F

1. Disconnect rubber tube connected to EVAP canister vent control valve.
2. Check the rubber tube for clogging.

OK or NG

- OK >> GO TO 11.
NG >> Clean the rubber tube using an air blower.

G

H

11. CHECK EVAP CANISTER VENT CONTROL VALVE

Refer to [EC-347, "Component Inspection"](#) .

I

OK or NG

- OK >> GO TO 12.
NG >> Replace EVAP canister vent control valve.

J

12. CHECK EVAP PURGE LINE

K

Inspect EVAP purge line (pipe and rubber tube). Check for evidence of leaks.

Refer to [EC-644, "EVAPORATIVE EMISSION LINE DRAWING"](#) .

OK or NG

- OK >> GO TO 13.
NG >> Replace it.

L

13. CLEAN EVAP PURGE LINE

M

Clean EVAP purge line (pipe and rubber tube) using air blower.

>> GO TO 14.

14. CHECK INTERMITTENT INCIDENT

Refer to [EC-135, "TROUBLE DIAGNOSIS FOR INTERMITTENT INCIDENT"](#) .

>> INSPECTION END

DTC P0442 EVAP CONTROL SYSTEM

PFP:14950

On Board Diagnosis Logic

ABS006QQ

This diagnosis detects leaks in the EVAP purge line using engine intake manifold vacuum. If pressure does not increase, the ECM will check for leaks in the line between the fuel tank and EVAP canister purge volume control solenoid valve, under the following Vacuum test conditions. The EVAP canister vent control valve is closed to shut the EVAP purge line off. The EVAP canister purge volume control solenoid valve will then be opened to depressurize the EVAP purge line using intake manifold vacuum. After this occurs, the EVAP canister purge volume control solenoid valve will be closed.

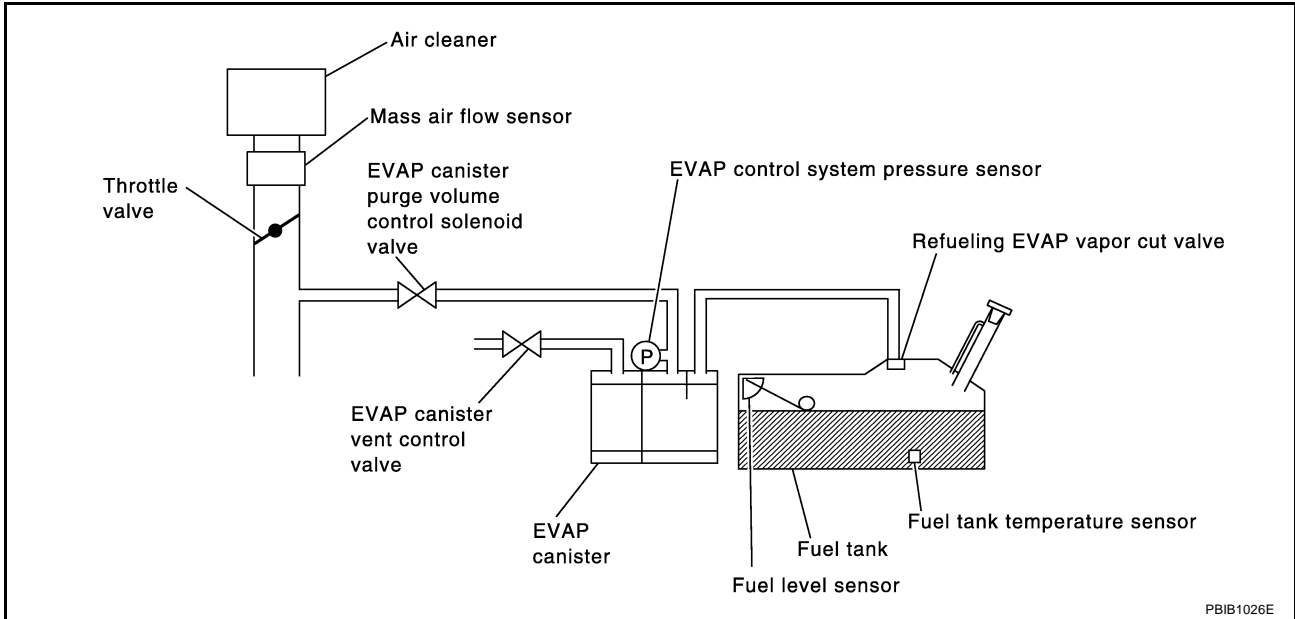

DTC No.	Trouble diagnosis name	DTC detecting condition	Possible cause
P0442 0442	EVAP control system small leak detected (negative pressure)	EVAP control system has a leak, EVAP control system does not operate properly.	<ul style="list-style-type: none"> ● Incorrect fuel tank vacuum relief valve ● Incorrect fuel filler cap used ● Fuel filler cap remains open or fails to close. ● Foreign matter caught in fuel filler cap. ● Leak is in line between intake manifold and EVAP canister purge volume control solenoid valve. ● Foreign matter caught in EVAP canister vent control valve. ● EVAP canister or fuel tank leaks ● EVAP purge line (pipe and rubber tube) leaks ● EVAP purge line rubber tube bent ● Loose or disconnected rubber tube ● EVAP canister vent control valve and the circuit ● EVAP canister purge volume control solenoid valve and the circuit ● Fuel tank temperature sensor ● O-ring of EVAP canister vent control valve is missing or damaged ● EVAP canister is saturated with water ● EVAP control system pressure sensor ● Fuel level sensor and the circuit ● Refueling EVAP vapor cut valve ● ORVR system leaks

CAUTION:

- Use only a genuine NISSAN fuel filler cap as a replacement. If an incorrect fuel filler cap is used, the MIL may come on.
- If the fuel filler cap is not tightened properly, the MIL may come on.
- Use only a genuine NISSAN rubber tube as a replacement.

DTC Confirmation Procedure

ABS006QR

NOTE:

- If DTC Confirmation Procedure has been previously conducted, always turn ignition switch OFF and wait at least 10 seconds before conducting the next test.

TESTING CONDITION:

- Perform "DTC WORK SUPPORT" when the fuel level is between 1/4 and 3/4 full, and vehicle is placed on flat level surface.
- Always perform test at a temperature of 0 to 30°C (32 to 86°F).

WITH CONSULT-II

1. Turn ignition switch ON.
2. Turn ignition switch OFF and wait at least 10 seconds.
3. Turn ignition switch ON and select "DATA MONITOR" mode with CONSULT-II.
4. Make sure that the following conditions are met.
COOLAN TEMP/S: 0 - 70°C (32 - 158°F)
INT/A TEMP SE: 0 - 30°C (32 - 86°F)
5. Select "EVAP SML LEAK P0442/P1442" of "EVAPORATIVE SYSTEM" in "DTC WORK SUPPORT" mode with CONSULT-II.
 Follow the instruction displayed.

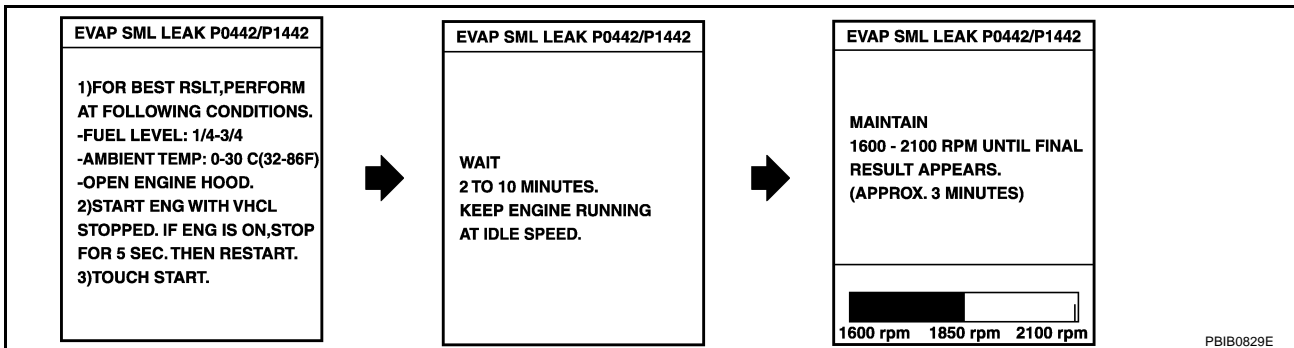

NOTE:

If the engine speed cannot be maintained within the range displayed on the CONSULT-II screen, go to [EC-83, "Basic Inspection"](#).

6. Make sure that "OK" is displayed.
 If "NG" is displayed, refer to [EC-328, "Diagnostic Procedure"](#).

NOTE:

Make sure that EVAP hoses are connected to EVAP canister purge volume control solenoid valve properly.

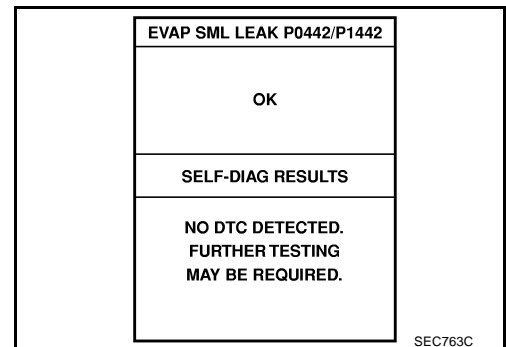

WITH GST

NOTE:

Be sure to read the explanation of [EC-64, "Driving Pattern"](#) before driving vehicle.

1. Start engine.
2. Drive vehicle according to [EC-64, "Driving Pattern"](#).
3. Stop vehicle.

4. Turn ignition switch OFF, wait at least 10 seconds, and then turn ON.
5. Select MODE 7 with GST.
 - If P0442 is displayed on the screen, go to [EC-328, "Diagnostic Procedure"](#) .
 - If P0441 is displayed on the screen, go to [EC-323, "Diagnostic Procedure"](#) .

Diagnostic Procedure

ABS006QS

1. CHECK FUEL FILLER CAP DESIGN

1. Turn ignition switch OFF.
2. Check for genuine NISSAN fuel filler cap design.

OK or NG

- OK >> GO TO 2.
NG >> Replace with genuine NISSAN fuel filler cap.

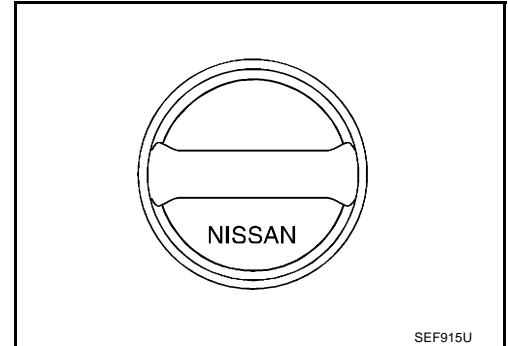

2. CHECK FUEL FILLER CAP INSTALLATION

Check that the cap is tightened properly by rotating the cap clockwise.

OK or NG

- OK >> GO TO 3.
NG >> 1. Open fuel filler cap, then clean cap and fuel filler neck threads using air blower.
2. Retighten until ratcheting sound is heard.

3. CHECK FUEL FILLER CAP FUNCTION

Check for air releasing sound while opening the fuel filler cap.

OK or NG

- OK >> GO TO 5.
NG >> GO TO 4.

4. CHECK FUEL TANK VACUUM RELIEF VALVE

Refer to [EC-646, "FUEL TANK VACUUM RELIEF VALVE \(BUILT INTO FUEL FULLER CAP\)"](#) .

OK or NG

- OK >> GO TO 5.
NG >> Replace fuel filler cap with a genuine one.

5. INSTALL THE PRESSURE PUMP

To locate the EVAP leak, install EVAP service port adapter and pressure pump to EVAP service port securely. For the location of EVAP service port, refer to [EC-644, "EVAPORATIVE EMISSION LINE DRAWING"](#).

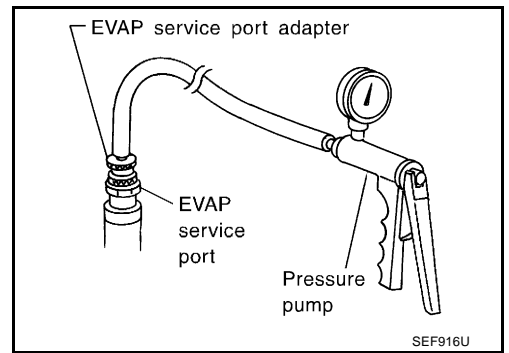
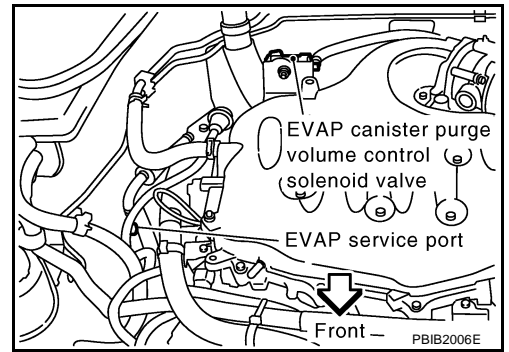

NOTE:

Improper installation of the EVAP service port adapter to the EVAP service port may cause leaking.

Models with CONSULT-II>>>GO TO 6.
 Models without CONSULT-II>>>GO TO 7.

A
 EC
 C
 D
 E
 F
 G
 H
 I
 J
 K
 L
 M

6. CHECK FOR EVAP LEAK

With CONSULT-II

1. Turn ignition switch ON.
2. Select "EVAP SYSTEM CLOSE" of "WORK SUPPORT" mode with CONSULT-II.
3. Touch "START" and apply pressure into the EVAP line until the pressure indicator reaches the middle of the bar graph.

NOTE:

- Never use compressed air or a high pressure pump.
- Do not exceed 4.12 kPa (0.042 kg/cm² , 0.6 psi) of pressure in the system.

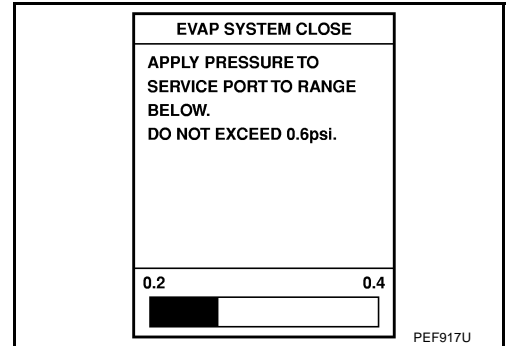

4. Using EVAP leak detector, locate the EVAP leak. For the leak detector, refer to the instruction manual for more details. Refer to [EC-644, "EVAPORATIVE EMISSION LINE DRAWING"](#)

OK or NG

- OK >> GO TO 8.
 NG >> Repair or replace.

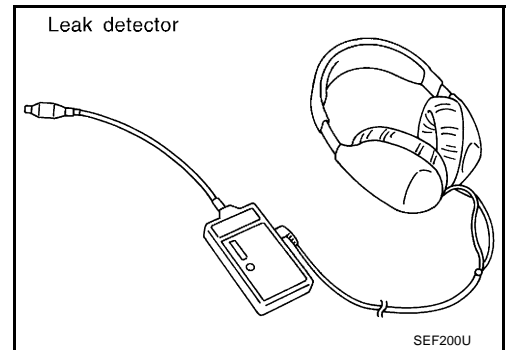

7. CHECK FOR EVAP LEAK

⊗ **Without CONSULT-II**

1. Turn ignition switch OFF.
2. Apply 12 volts DC to EVAP canister vent control valve. The valve will close. (Continue to apply 12 volts until the end of test.)

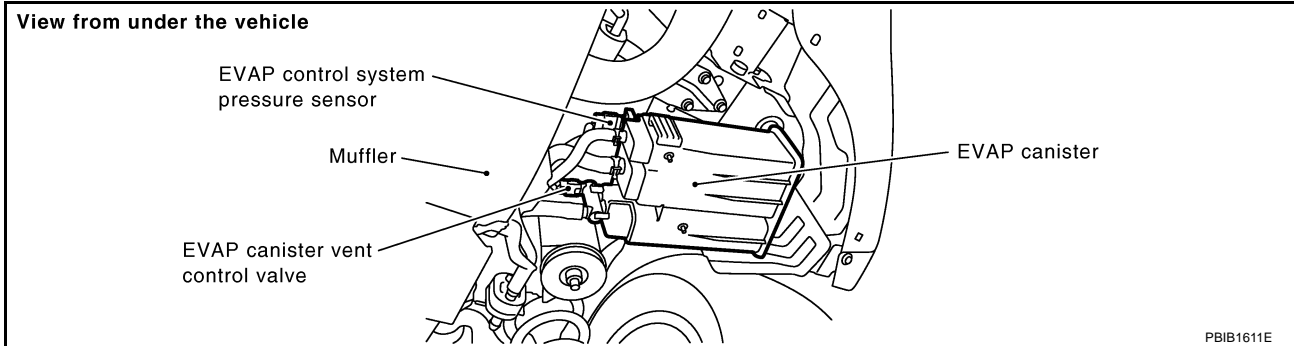

3. Pressurize the EVAP line using pressure pump with 1.3 to 2.7 kPa (10 to 20 mmHg, 0.39 to 0.79 inHg), then remove pump and EVAP service port adapter.

NOTE:

- Never use compressed air or a high pressure pump.
- Do not exceed 4.12 kPa (0.042 kg/cm², 0.6 psi) of pressure in the system.

4. Using EVAP leak detector, locate the EVAP leak. For the leak detector, refer to the instruction manual for more details. Refer to [EC-644, "EVAPORATIVE EMISSION LINE DRAWING"](#).

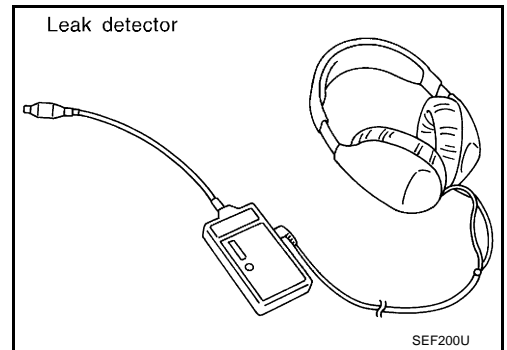

OK or NG

- OK >> GO TO 8.
 NG >> Repair or replace.

8. CHECK EVAP CANISTER VENT CONTROL VALVE

Check the following.

- EVAP canister vent control valve is installed properly. Refer to [EC-647, "Removal and Installation"](#).
- EVAP canister vent control valve. Refer to [EC-646, "Component Inspection"](#).

OK or NG

- OK >> GO TO 9.
 NG >> Repair or replace EVAP canister vent control valve and O-ring.

9. CHECK IF EVAP CANISTER SATURATED WITH WATER

1. Remove EVAP canister with EVAP canister vent control valve and EVAP control system pressure sensor attached.
2. Does water drain from the EVAP canister?

Yes or No

- Yes >> GO TO 10.
 No (With CONSULT-II)>>GO TO 12.
 No (Without CONSULT-II)>>GO TO 13.

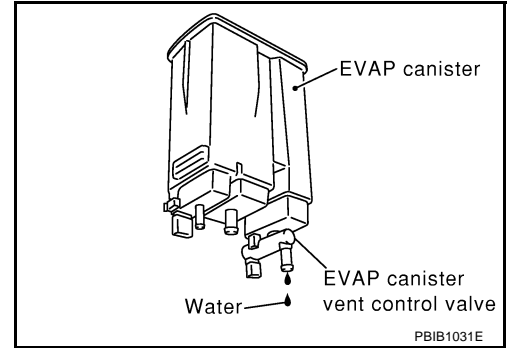

10. CHECK EVAP CANISTER

Weigh the EVAP canister with the EVAP canister vent control valve and EVAP control system pressure sensor attached.

The weight should be less than 2.1 kg (4.6 lb).

OK or NG

- OK (With CONSULT-II)>>GO TO 12.
 OK (Without CONSULT-II)>>GO TO 13.
 NG >> GO TO 11.

11. DETECT MALFUNCTIONING PART

Check the following.

- EVAP canister for damage
- EVAP hose between EVAP canister and vehicle frame for clogging or poor connection

>> Repair hose or replace EVAP canister.

12. CHECK EVAP CANISTER PURGE VOLUME CONTROL SOLENOID VALVE OPERATION

Ⓟ With CONSULT-II

1. Disconnect vacuum hose to EVAP canister purge volume control solenoid valve at EVAP service port.
2. Start engine.
3. Perform "PURG VOL CONT/V" in "ACTIVE TEST" mode.
4. Touch "Qu" on CONSULT-II screen to increase "PURG VOL CONT/V" opening to 100%.
5. Check vacuum hose for vacuum when revving engine up to 2,000 rpm.

OK or NG

- OK >> GO TO 15.
 NG >> GO TO 14.

ACTIVE TEST	
PURG VOL CONT/V	0 %
MONITOR	
ENG SPEED	XXX rpm
HO2S1 MNTR (B1)	LEAN
HO2S1 MNTR (B2)	LEAN
A/F ALPHA-B1	XXX %
A/F ALPHA-B2	XXX %

PBIB0147E

13. CHECK EVAP CANISTER PURGE VOLUME CONTROL SOLENOID VALVE OPERATION**⊗ Without CONSULT-II**

1. Start engine and warm it up to normal operating temperature.
2. Stop engine.
3. Disconnect vacuum hose to EVAP canister purge volume control solenoid valve at EVAP service port.
4. Start engine and let it idle for at least 80 seconds.
5. Check vacuum hose for vacuum when revving engine up to 2,000 rpm.

Vacuum should exist.

OK or NG

- OK >> GO TO 16.
 NG >> GO TO 14.

14. CHECK VACUUM HOSE

Check vacuum hoses for clogging or disconnection. Refer to [EC-30, "Vacuum Hose Drawing"](#).

OK or NG

- OK >> GO TO 15.
 NG >> Repair or reconnect the hose.

15. CHECK EVAP CANISTER PURGE VOLUME CONTROL SOLENOID VALVE

Refer to [EC-340, "Component Inspection"](#).

OK or NG

- OK >> GO TO 16.
 NG >> Replace EVAP canister purge volume control solenoid valve.

16. CHECK FUEL TANK TEMPERATURE SENSOR

Refer to [EC-277, "Component Inspection"](#).

OK or NG

- OK >> GO TO 17.
 NG >> Replace fuel level sensor unit.

17. CHECK EVAP CONTROL SYSTEM PRESSURE SENSOR

Refer to [EC-357, "Component Inspection"](#).

OK or NG

- OK >> GO TO 18.
 NG >> Replace EVAP control system pressure sensor.

18. CHECK EVAP PURGE LINE

Check EVAP purge line (pipe, rubber tube, fuel tank and EVAP canister) for cracks or improper connection. Refer to [EC-644, "EVAPORATIVE EMISSION LINE DRAWING"](#).

OK or NG

- OK >> GO TO 19.
 NG >> Repair or reconnect the hose.

19. CLEAN EVAP PURGE LINE

Clean EVAP purge line (pipe and rubber tube) using air blower.

>> GO TO 20.

20. CHECK EVAP/ORVR LINE

Check EVAP/ORVR line between EVAP canister and fuel tank for clogging, kink, looseness and improper connection. For location, refer to [EC-650, "ON BOARD REFUELING VAPOR RECOVERY \(ORVR\)"](#) .

OK or NG

OK >> GO TO 21.

NG >> Repair or replace hoses and tubes.

21. CHECK RECIRCULATION LINE

Check recirculation line between filler neck tube and fuel tank for clogging, kink, cracks, looseness and improper connection.

OK or NG

OK >> GO TO 22.

NG >> Repair or replace hose, tube or filler neck tube.

22. CHECK REFUELING EVAP VAPOR CUT VALVE

Refer to [EC-653, "Component Inspection"](#) .

OK or NG

OK >> GO TO 23.

NG >> Replace refueling EVAP vapor cut valve with fuel tank.

23. CHECK FUEL LEVEL SENSOR

Refer to [DI-25, "CHECK FUEL LEVEL SENSOR UNIT"](#) .

OK or NG

OK >> GO TO 24.

NG >> Replace fuel level sensor unit.

24. CHECK INTERMITTENT INCIDENT

Refer to [EC-135, "TROUBLE DIAGNOSIS FOR INTERMITTENT INCIDENT"](#) .

>> **INSPECTION END**

DTC P0444, P0445 EVAP CANISTER PURGE VOLUME CONTROL SOLENOID VALVE

[VQ35DE]

DTC P0444, P0445 EVAP CANISTER PURGE VOLUME CONTROL SOLENOID VALVE

PFP:14920

Description SYSTEM DESCRIPTION

ABS0060T

Sensor	Input signal to ECM	ECM function	Actuator
Crankshaft position sensor (POS) Camshaft position sensor (PHASE)	Engine speed*1	EVAP canister purge flow control	EVAP canister purge vol- ume control solenoid valve
Mass air flow sensor	Amount of intake air		
Engine coolant temperature sensor	Engine coolant temperature		
Battery	Battery voltage*1		
Throttle position sensor	Throttle position		
Accelerator pedal position sensor	Accelerator pedal position		
Heated oxygen sensors 1	Density of oxygen in exhaust gas (Mixture ratio feedback signal)		
Fuel tank temperature sensor	Fuel temperature in fuel tank		
Wheel sensor*2	Vehicle speed		

*1:ECM determines the start signal status by the signals of engine speed and battery voltage.

*2: This signal is sent to the ECM through CAN communication line.

This system controls flow rate of fuel vapor from the EVAP canister. The opening of the vapor by-pass passage in the EVAP canister purge volume control solenoid valve changes to control the flow rate. The EVAP canister purge volume control solenoid valve repeats ON/OFF operation according to the signal sent from the ECM. The opening of the valve varies for optimum engine control. The optimum value stored in the ECM is determined by considering various engine conditions. When the engine is operating, the flow rate of fuel vapor from the EVAP canister is regulated as the air flow changes.

COMPONENT DESCRIPTION

The EVAP canister purge volume control solenoid valve uses a ON/OFF duty to control the flow rate of fuel vapor from the EVAP canister. The EVAP canister purge volume control solenoid valve is moved by ON/OFF pulses from the ECM. The longer the ON pulse, the greater the amount of fuel vapor that will flow through the valve.

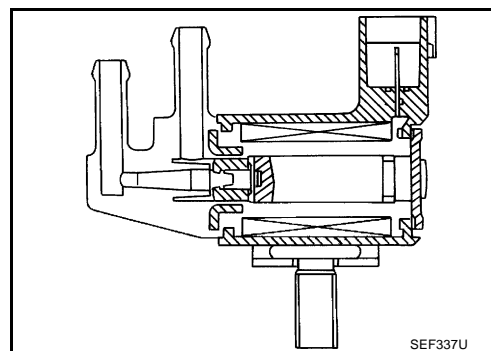

CONSULT-II Reference Value in Data Monitor Mode

ABS006QU

Specification data are reference values.

MONITOR ITEM	CONDITION	SPECIFICATION
PURG VOL C/V	● Engine: After warming up ● Shift lever: P or N	Idle
	● Air conditioner switch: OFF ● No-load	2,000 rpm
		0%
		—

DTC P0444, P0445 EVAP CANISTER PURGE VOLUME CONTROL SOLENOID VALVE

[VQ35DE]

On Board Diagnosis Logic

ABS006QV

DTC No.	Trouble diagnosis name	DTC detecting condition	Possible cause
P0444 0444	EVAP canister purge volume control solenoid valve circuit open	An excessively low voltage signal is sent to ECM through the valve	<ul style="list-style-type: none"> ● Harness or connectors (The solenoid valve circuit is open or shorted.) ● EVAP canister purge volume control solenoid valve
P0445 0445	EVAP canister purge volume control solenoid valve circuit shorted	An excessively high voltage signal is sent to ECM through the valve	<ul style="list-style-type: none"> ● Harness or connectors (The solenoid valve circuit is shorted.) ● EVAP canister purge volume control solenoid valve

DTC Confirmation Procedure

ABS006QW

NOTE:

If DTC Confirmation Procedure has been previously conducted, always turn ignition switch OFF and wait at least 10 seconds before conducting the next test.

TESTING CONDITION:

Before performing the following procedure, confirm battery voltage is more than 11V at idle.

WITH CONSULT-II

1. Turn ignition switch ON.
2. Select "DATA MONITOR" mode with CONSULT-II.
3. Start engine and let it idle for at least 13 seconds.
4. If 1st trip DTC is detected, go to [EC-339, "Diagnostic Procedure"](#)

DATA MONITOR	
MONITOR	NO DTC
ENG SPEED	XXX rpm

SEF058Y

WITH GST

Follow the procedure "WITH CONSULT-II" above.

DTC P0444, P0445 EVAP CANISTER PURGE VOLUME CONTROL SOLENOID VALVE

[VQ35DE]

ABS006QX

Wiring Diagram

EC-PGC/V-01

: DETECTABLE LINE FOR DTC
 : NON-DETECTABLE LINE FOR DTC

REFER TO PG-POWER.

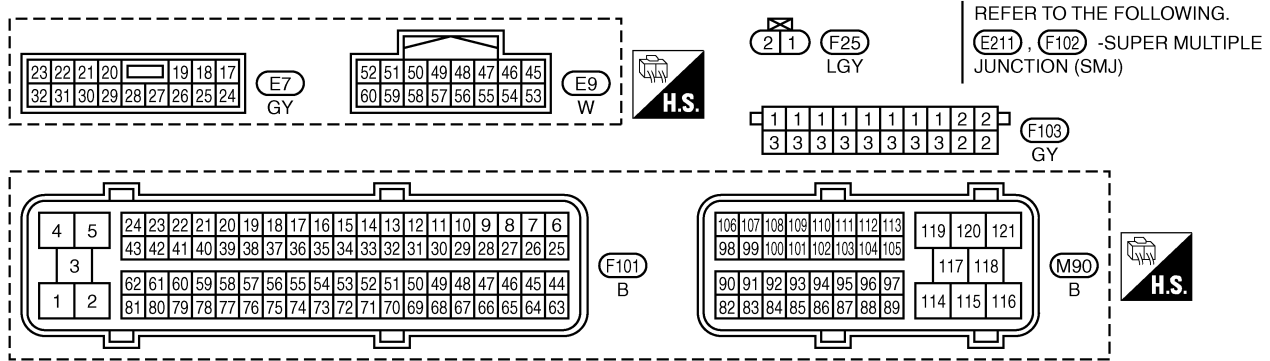
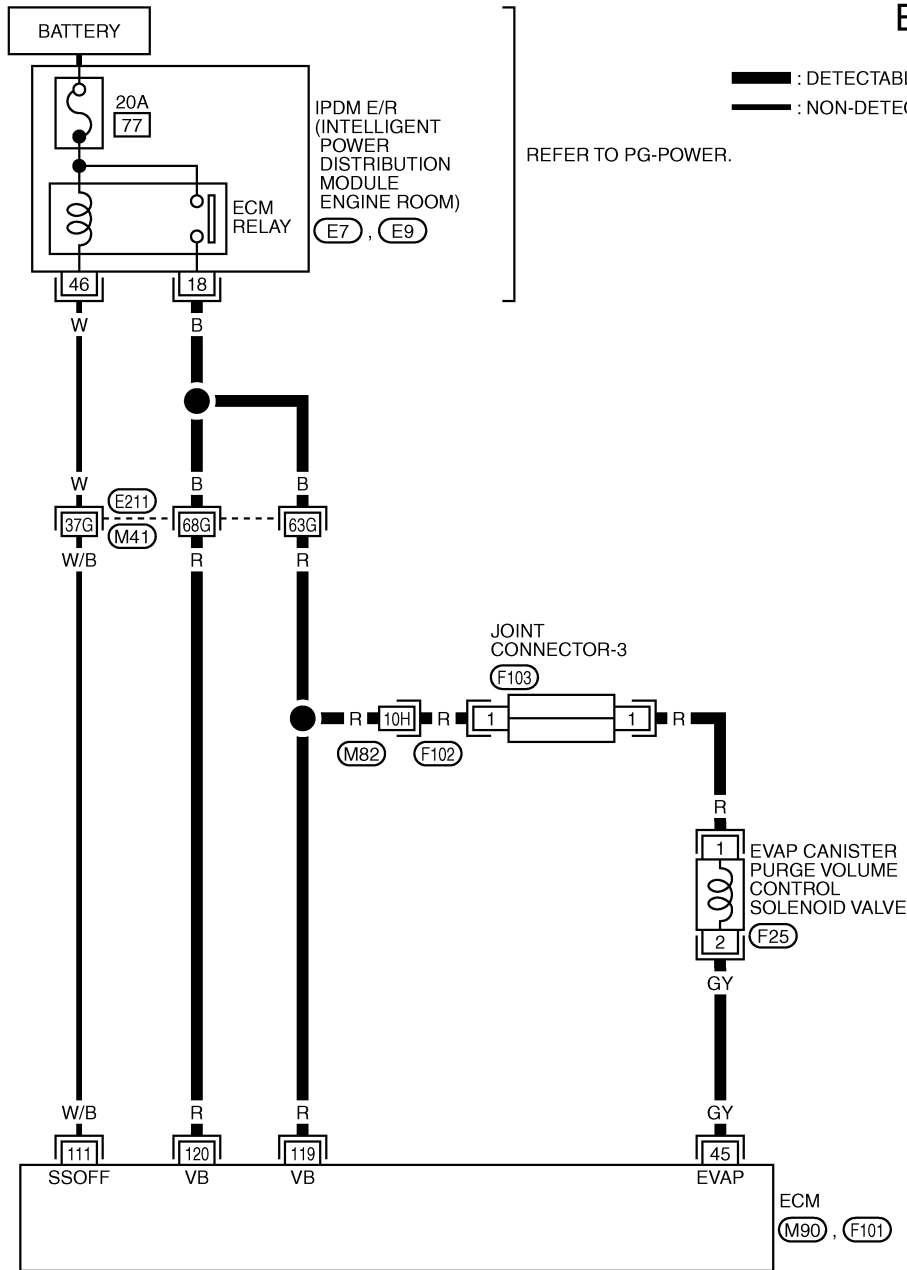

TBWM0300E

DTC P0444, P0445 EVAP CANISTER PURGE VOLUME CONTROL SOLENOID VALVE

[VQ35DE]

Specification data are reference values and are measured between each terminal and ground.
Pulse signal is measured by CONSULT-II.

CAUTION:

Do not use ECM ground terminals when measuring input/output voltage. Doing so may result in damage to the ECM's transistor. Use a ground other than ECM terminals, such as the ground.

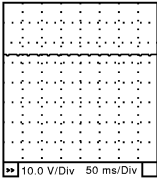
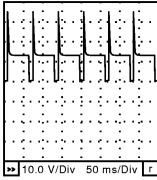
TER-MINAL NO.	WIRE COLOR	ITEM	CONDITION	DATA (DC Voltage)
45	GY	EVAP canister purge volume control solenoid valve	<p>[Engine is running]</p> <ul style="list-style-type: none"> ● Idle speed 	<p>BATTERY VOLTAGE (11 - 14V)★</p> 
			<p>[Engine is running]</p> <ul style="list-style-type: none"> ● Engine speed is about 2,000 rpm (More than 100 seconds after starting engine) 	<p>BATTERY VOLTAGE (11 - 14V)★</p> 
111	W/B	ECM relay (Self shut-off)	<p>[Engine is running] [Ignition switch: OFF]</p> <ul style="list-style-type: none"> ● For a few seconds after turning ignition switch OFF 	0 - 1.5V
			<p>[Ignition switch: OFF]</p> <ul style="list-style-type: none"> ● More than a few seconds after turning ignition switch OFF 	BATTERY VOLTAGE (11 - 14V)
119 120	R R	Power supply for ECM	[Ignition switch: ON]	BATTERY VOLTAGE (11 - 14V)

★: Average voltage for pulse signal (Actual pulse signal can be confirmed by oscilloscope.)

Diagnostic Procedure

1. CHECK EVAP CANISTER PURGE VOLUME CONTROL SOLENOID VALVE POWER SUPPLY CIRCUIT

1. Turn ignition switch OFF.
2. Disconnect EVAP canister purge volume control solenoid valve harness connector.
3. Turn ignition switch ON.

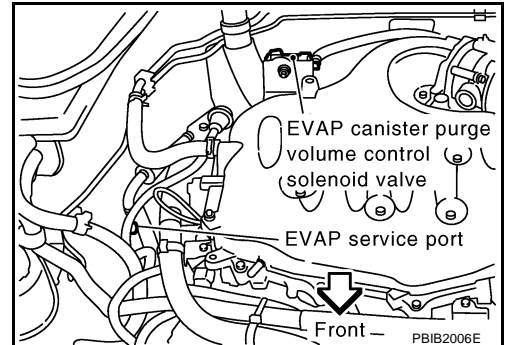

4. Check voltage between EVAP canister purge volume control solenoid valve terminal 1 and ground with CONSULT-II or tester.

Voltage: Battery voltage

OK or NG

- OK >> GO TO 3.
- NG >> GO TO 2.

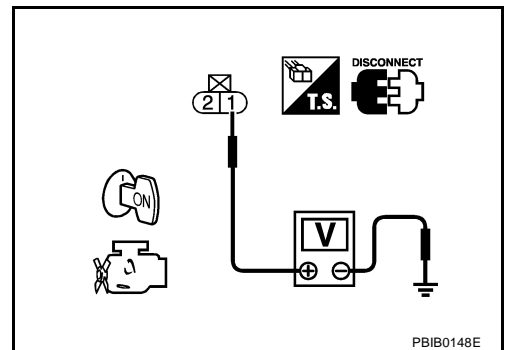

2. DETECT MALFUNCTIONING PART

Check the following.

- Harness connectors E211, M41
- Harness connectors M82, F102
- Joint connector-3
- IPDM E/R harness connector E7
- 20A fuse
- Harness for open or short between EVAP canister purge volume control solenoid valve and IPDM E/R
- Harness for open or short between EVAP canister purge volume control solenoid valve and ECM

>> Repair harness or connectors.

3. CHECK EVAP CANISTER PURGE VOLUME CONTROL SOLENOID VALVE OUTPUT SIGNAL CIRCUIT FOR OPEN AND SHORT

1. Turn ignition switch OFF.
2. Disconnect ECM harness connector.
3. Check harness continuity between ECM terminal 45 and EVAP canister purge volume control solenoid valve terminal 2. Refer to Wiring Diagram.

Continuity should exist.

4. Also check harness for short to ground and short to power.

OK or NG

- OK (With CONSULT-II) >> GO TO 4.
- OK (Without CONSULT-II) >> GO TO 5.
- NG >> Repair open circuit or short to ground or short to power in harness or connectors.

DTC P0444, P0445 EVAP CANISTER PURGE VOLUME CONTROL SOLENOID VALVE

[VQ35DE]

4. CHECK EVAP CANISTER PURGE VOLUME CONTROL SOLENOID VALVE OPERATION

With CONSULT-II

1. Reconnect all harness connectors disconnected.
2. Start engine.
3. Perform "PURG VOL CONT/V" in "ACTIVE TEST" mode with CONSULT-II. Check that engine speed varies according to the valve opening.

OK or NG

- OK >> GO TO 6.
NG >> GO TO 5.

ACTIVE TEST	
PURG VOL CONT/V	0 %
MONITOR	
ENG SPEED	XXX rpm
HO2S1 MNTR (B1)	LEAN
HO2S1 MNTR (B2)	LEAN
A/F ALPHA-B1	XXX %
A/F ALPHA-B2	XXX %

PBIB0147E

5. CHECK EVAP CANISTER PURGE VOLUME CONTROL SOLENOID VALVE

Refer to [EC-340, "Component Inspection"](#) .

OK or NG

- OK >> GO TO 6.
NG >> Replace EVAP canister purge volume control solenoid valve.

6. CHECK INTERMITTENT INCIDENT

Refer to [EC-135, "TROUBLE DIAGNOSIS FOR INTERMITTENT INCIDENT"](#) .

>> INSPECTION END

Component Inspection EVAP CANISTER PURGE VOLUME CONTROL SOLENOID VALVE

ABS006QZ

With CONSULT-II

Check air passage continuity of EVAP canister purge volume control solenoid valve under the following conditions.

Condition (PURG VOL CONT/V value)	Air passage continuity between A and B
100%	Yes
0%	No

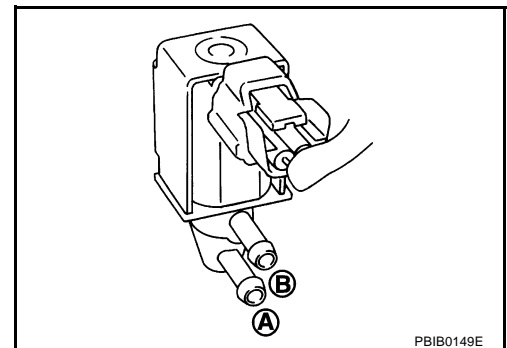

Without CONSULT-II

Check air passage continuity of EVAP canister purge volume control solenoid valve under the following conditions.

Condition	Air passage continuity between A and B
12V direct current supply between terminals 1 and 2	Yes
No supply	No

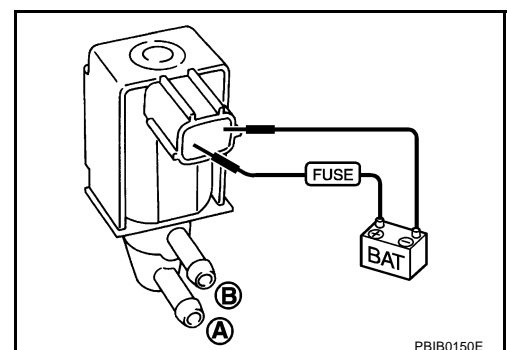

DTC P0444, P0445 EVAP CANISTER PURGE VOLUME CONTROL SOLENOID VALVE

[VQ35DE]

Removal and Installation

ABS006R0

EVAP CANISTER PURGE VOLUME CONTROL SOLENOID VALVE

Refer to [EM-19, "INTAKE MANIFOLD COLLECTOR"](#) .

A

EC

C

D

E

F

G

H

I

J

K

L

M

DTC P0447 EVAP CANISTER VENT CONTROL VALVE

PFP:14935

Component Description

ABS006R1

The EVAP canister vent control valve is located on the EVAP canister and is used to seal the canister vent. This solenoid valve responds to signals from the ECM. When the ECM sends an ON signal, the coil in the solenoid valve is energized. A plunger will then move to seal the canister vent. The ability to seal the vent is necessary for the on board diagnosis of other evaporative emission control system components. This solenoid valve is used only for diagnosis, and usually remains opened. When the vent is closed, under normal purge conditions, the evaporative emission control system is depressurized and allows EVAP Control System diagnosis.

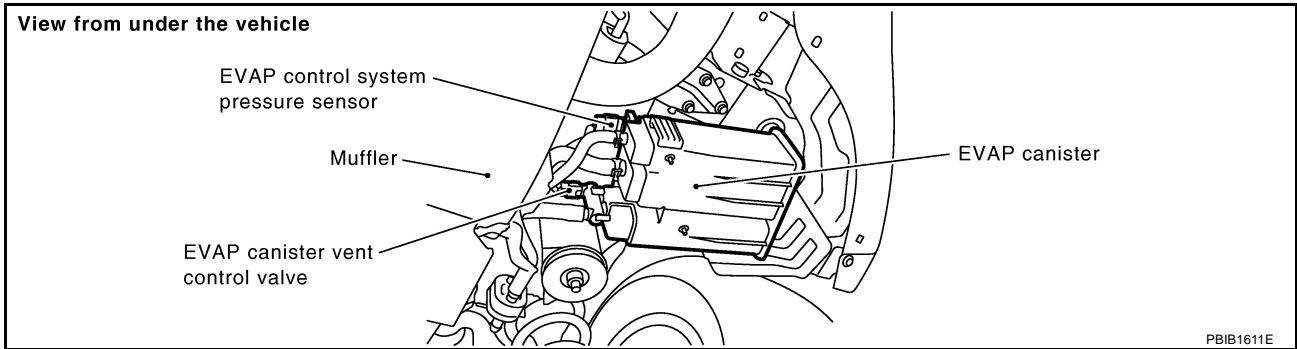
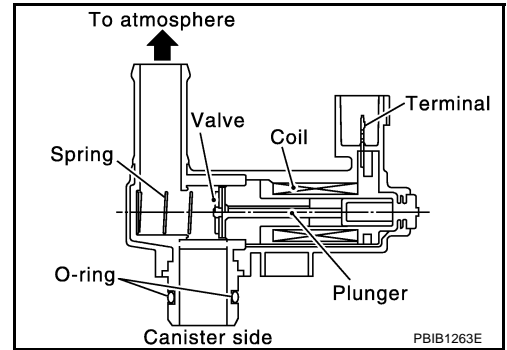

CONSULT-II Reference Value in Data Monitor Mode

ABS006R2

Specification data are reference values.

MONITOR ITEM	CONDITION	SPECIFICATION
VENT CONT/V	● Ignition switch: ON	OFF

On Board Diagnosis Logic

ABS006R3

DTC No.	Trouble diagnosis name	DTC detecting condition	Possible cause
P0447 0447	EVAP canister vent control valve circuit open	An improper voltage signal is sent to ECM through EVAP canister vent control valve.	<ul style="list-style-type: none"> ● Harness or connectors (The valve circuit is open or shorted.) ● EVAP canister vent control valve

DTC Confirmation Procedure**NOTE:**

If DTC Confirmation Procedure has been previously conducted, always turn ignition switch OFF and wait at least 10 seconds before conducting the next test.

TESTING CONDITION:

Before performing the following procedure, confirm battery voltage is more than 11V at idle.

 **WITH CONSULT-II**

1. Turn ignition switch ON.
2. Select "DATA MONITOR" mode with CONSULT-II.
3. Start engine and wait at least 8 seconds.
4. If 1st trip DTC is detected, go to [EC-345, "Diagnostic Procedure"](#)

DATA MONITOR	
MONITOR	NO DTC
ENG SPEED	XXX rpm

SEF058Y

 **WITH GST**

Follow the procedure "WITH CONSULT-II" above.

A

EC

C

D

E

F

G

H

I

J

K

L

M

DTC P0447 EVAP CANISTER VENT CONTROL VALVE

[VQ35DE]

ABS006R5

Wiring Diagram

EC-VENT/V-01

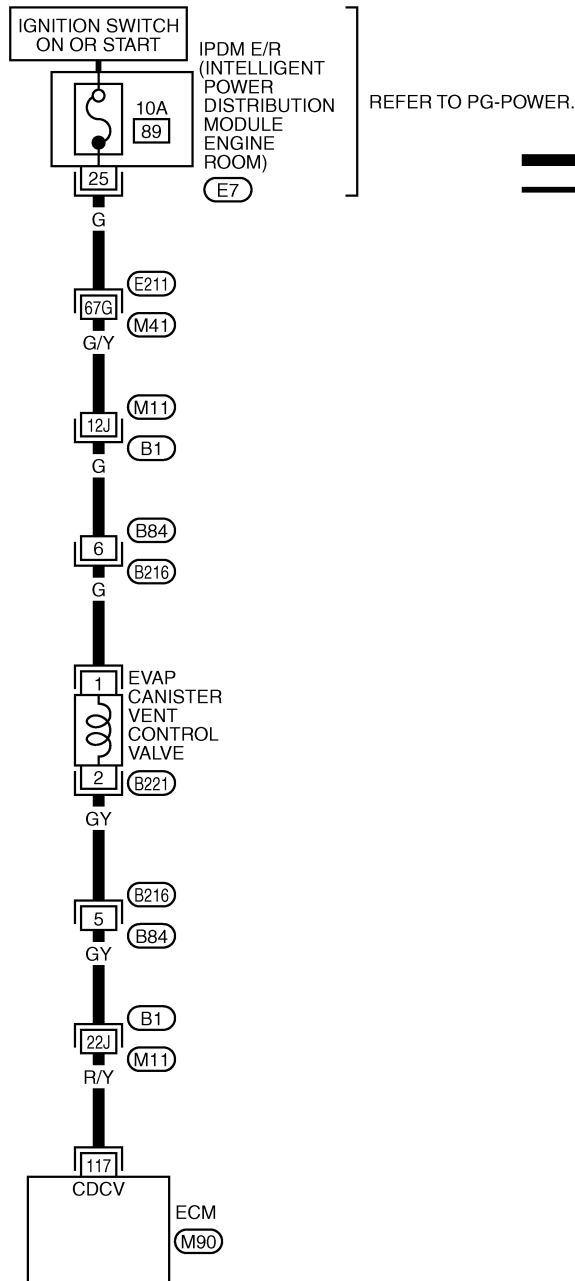

: DETECTABLE LINE FOR DTC
 : NON-DETECTABLE LINE FOR DTC

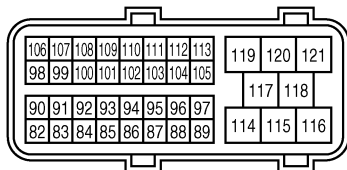

(M90)
B

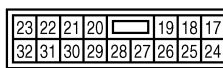

(E7)
GY



REFER TO THE FOLLOWING.

(E211), (B1) -SUPER MULTIPLE JUNCTION (SMJ)



(B216)
GY

(B221)
B

TBWH0110E

DTC P0447 EVAP CANISTER VENT CONTROL VALVE

[VQ35DE]

Specification data are reference values and are measured between each terminal and ground.

CAUTION:

Do not use ECM ground terminals when measuring input/output voltage. Doing so may result in damage to the ECM's transistor. Use a ground other than ECM terminals, such as the ground.

TER-MINAL NO.	WIRE COLOR	ITEM	CONDITION	DATA (DC Voltage)
117	R/Y	EVAP canister vent control valve	[Ignition switch: ON]	BATTERY VOLTAGE (11 - 14V)

Diagnostic Procedure

ABS006R6

1. INSPECTION START

Do you have CONSULT-II?

Yes or No

- Yes >> GO TO 2.
- No >> GO TO 3.

2. CHECK EVAP CANISTER VENT CONTROL VALVE CIRCUIT

 **With CONSULT-II**

1. Turn ignition switch OFF and then turn ON.
2. Select "VENT CONTROL/V" in "ACTIVE TEST" mode with CONSULT-II.
3. Touch "ON/OFF" on CONSULT-II screen.
4. Check for operating sound of the valve.

Clicking noise should be heard.

OK or NG

- OK >> GO TO 7.
- NG >> GO TO 3.

ACTIVE TEST	
VENT CONTROL/V	OFF
MONITOR	
ENG SPEED	XXX rpm
A/F ALPHA-B1	XXX %
A/F ALPHA-B2	XXX %
HO2S1 (B1)	XXX V
HO2S1 (B2)	XXX V

PBIB0151E

3. CHECK EVAP CANISTER VENT CONTROL VALVE POWER SUPPLY CIRCUIT

1. Turn ignition switch OFF.
2. Disconnect EVAP canister vent control valve harness connector.

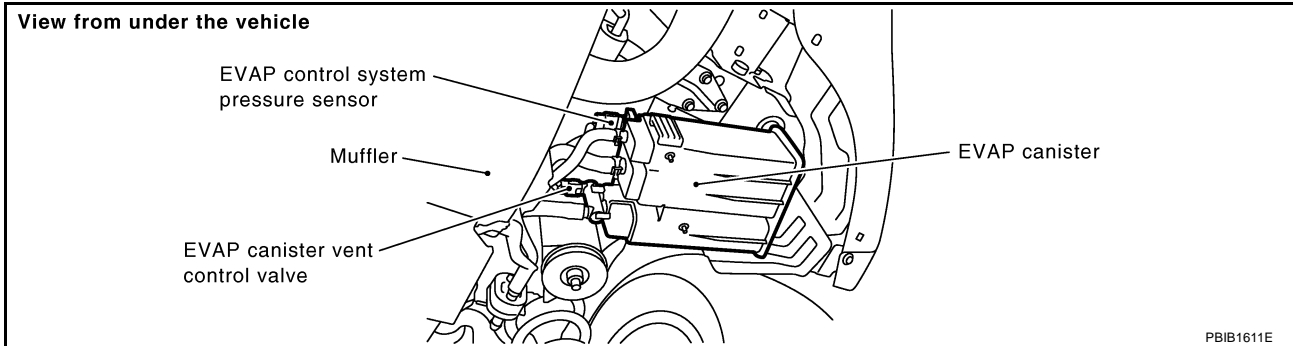

3. Turn ignition switch ON.
4. Check voltage between EVAP canister vent control valve terminal 1 and ground with CONSULT-II or tester.

Voltage: Battery voltage

OK or NG

- OK >> GO TO 5.
 NG >> GO TO 4.

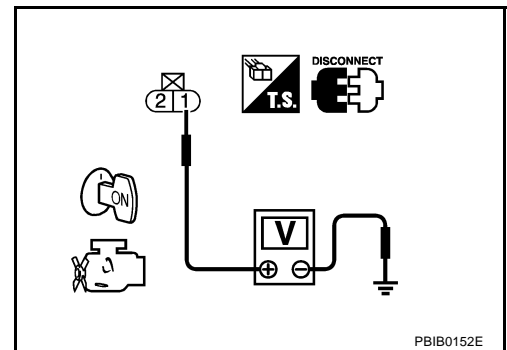

4. DETECT MALFUNCTIONING PART

Check the following.

- Harness connectors E211, M41
- Harness connectors M11, B1
- Harness connectors B84, B216
- IPDM E/R harness connector E7
- 10A fuse
- Harness for open or short between EVAP canister vent control valve and IPDM E/R

>> Repair harness or connectors.

5. CHECK EVAP CANISTER VENT CONTROL VALVE OUTPUT SIGNAL CIRCUIT FOR OPEN AND SHORT

1. Turn ignition switch OFF.
2. Disconnect ECM harness connector.
3. Check harness continuity between ECM terminal 117 and EVAP canister vent control valve terminal 2. Refer to Wiring Diagram.

Continuity should exist.

4. Also check harness for short to ground and short to power.

OK or NG

- OK >> GO TO 7.
 NG >> GO TO 6.

6. DETECT MALFUNCTIONING PART

Check the following.

- Harness connectors M11, B1
- Harness connectors B84, B216
- Harness for open or short between EVAP canister vent control valve and ECM

>> Repair open circuit or short to ground or short to power in harness or connectors.

7. CHECK RUBBER TUBE FOR CLOGGING

1. Disconnect rubber tube connected to EVAP canister vent control valve.
2. Check the rubber tube for clogging.

OK or NG

OK >> GO TO 8.

NG >> Clean the rubber tube using an air blower.

8. CHECK EVAP CANISTER VENT CONTROL VALVE

Refer to [EC-347, "Component Inspection"](#) .

OK or NG

OK >> GO TO 9.

NG >> Replace EVAP canister vent control valve.

9. CHECK INTERMITTENT INCIDENT

Refer to [EC-135, "TROUBLE DIAGNOSIS FOR INTERMITTENT INCIDENT"](#) .

>> INSPECTION END

Component Inspection EVAP CANISTER VENT CONTROL VALVE

ABS006R7

ⓑ With CONSULT-II

1. Remove EVAP canister vent control valve from EVAP canister.
2. Check portion **B** of EVAP canister vent control valve for being rusted.
If NG, replace EVAP canister vent control valve.
If OK, go to next step.
3. Reconnect harness connectors disconnected.
4. Turn ignition switch ON.

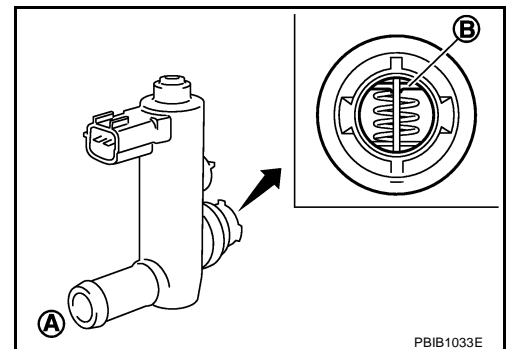

PBIB1033E

DTC P0447 EVAP CANISTER VENT CONTROL VALVE

[VQ35DE]

5. Perform "VENT CONTROL/V" in "ACTIVE TEST" mode.
6. Check air passage continuity and operation delay time.
Make sure new O-ring is installed properly.

Condition VENT CONTROL/V	Air passage continuity between A and B
ON	No
OFF	Yes

Operation takes less than 1 second.

If NG, replace EVAP canister vent control valve.
If OK, go to next step.

7. Clean the air passage (portion **A** to **B**) of EVAP canister vent control valve using an air blower.
8. Perform step 6 again.

⊗ **Without CONSULT-II**

1. Remove EVAP canister vent control valve from EVAP canister.
2. Check portion **B** of EVAP canister vent control valve for being rusted.

3. Check air passage continuity and operation delay time under the following conditions.
Make sure new O-ring is installed properly.

Condition	Air passage continuity between A and B
12V direct current supply between terminals 1 and 2	No
OFF	Yes

Operation takes less than 1 second.

If NG, replace EVAP canister vent control valve.
If OK, go to next step.

4. Clean the air passage (portion **A** to **B**) of EVAP canister vent control valve using an air blower.
5. Perform step 3 again.

ACTIVE TEST	
VENT CONTROL/V	OFF
MONITOR	
ENG SPEED	XXX rpm
A/F ALPHA-B1	XXX %
A/F ALPHA-B2	XXX %
HO2S1 (B1)	XXX V
HO2S1 (B2)	XXX V

PBIB0151E

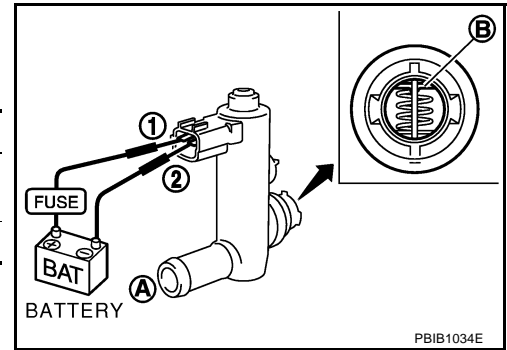
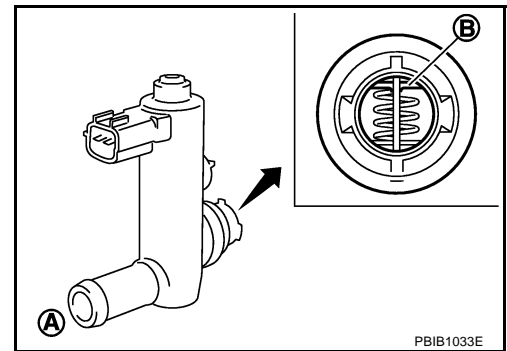

DTC P0451 EVAP CONTROL SYSTEM PRESSURE SENSOR

[VQ35DE]

DTC P0451 EVAP CONTROL SYSTEM PRESSURE SENSOR

PFP:22365

Component Description

ABS009VU

The EVAP control system pressure sensor detects pressure in the purge line. The sensor output voltage to the ECM increases as pressure increases.

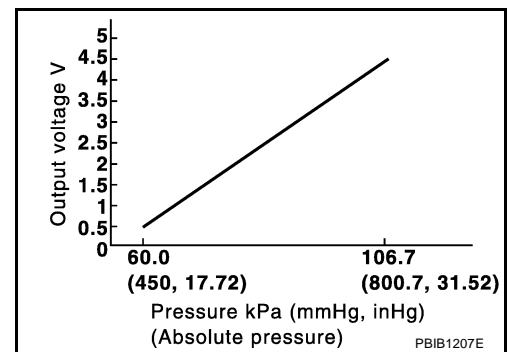
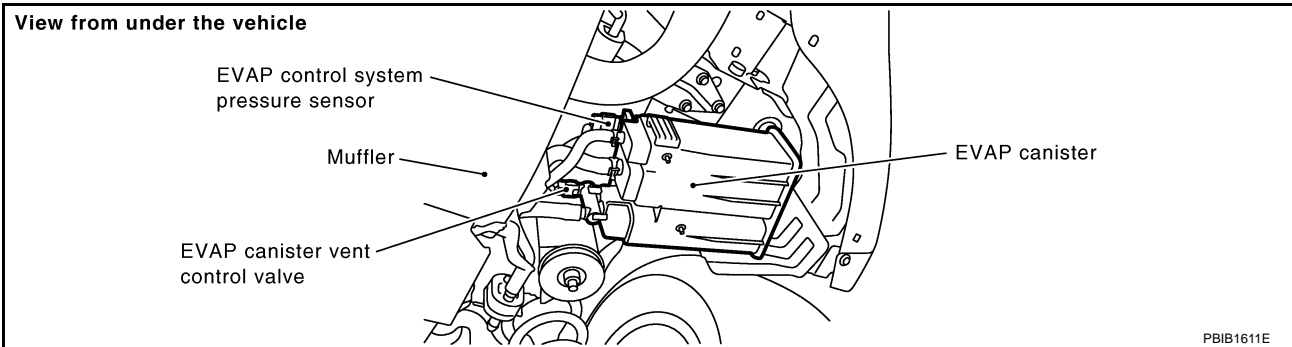

CONSULT-II Reference Value in Data Monitor Mode

ABS009VV

Specification data are reference values.

MONITOR ITEM	CONDITION	SPECIFICATION
EVAP SYS PRES	● Ignition switch: ON	Approx. 1.8 - 4.8V

On Board Diagnosis Logic

ABS009VW

NOTE:

If DTC P0451 is displayed with DTC P1229, first perform the trouble diagnosis for DTC P1229. Refer to [EC-489, "DTC P1229 SENSOR POWER SUPPLY"](#).

DTC No.	Trouble diagnosis name	DTC detecting condition	Possible cause
P0451 0451	EVAP control system pressure sensor performance	ECM detects a sloshing signal from the EVAP control system pressure sensor	<ul style="list-style-type: none"> ● Harness or connectors ● EVAP control system pressure sensor

DTC Confirmation Procedure

NOTE:

If DTC Confirmation Procedure has been previously conducted, always turn ignition switch OFF and wait at least 10 seconds before conducting the next test.

WITH CONSULT-II

1. Turn ignition switch OFF and wait at least 10 seconds.
2. Turn ignition switch ON and select "DATA MONITOR" mode with CONSULT-II.
3. Start engine and wait at least 40 seconds.

DATA MONITOR	
MONITOR	NO DTC
ENG SPEED	XXX rpm
COOLAN TEMP/S	XXX °C
FUEL T/TMP SE	XXX °C

SEF194Y

NOTE:

Do not depress accelerator pedal even slightly.

If 1st trip DTC is detected, go to [EC-350, "Diagnostic Procedure"](#)

WITH GST

Follow the procedure "WITH CONSULT-II" above.

Diagnostic Procedure

1. CHECK GROUND CONNECTIONS

1. Turn ignition switch OFF.
2. Loosen and retighten ground three screws on the body. Refer to [EC-141, "Ground Inspection"](#) .

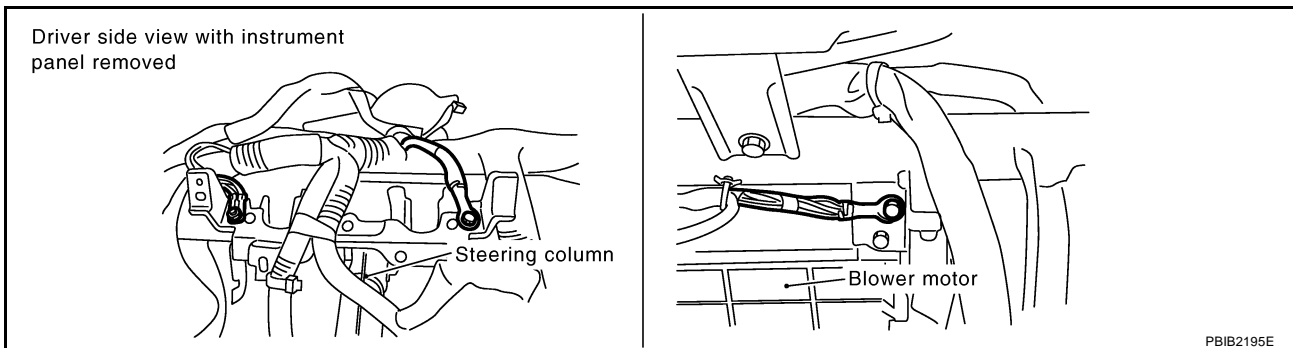

OK or NG

- OK >> GO TO 2.
 NG >> Repair or replace ground connections.

2. CHECK EVPA CONTROL SYSTEM PRESSURE SENSOR CONNECTOR FOR WATER

1. Disconnect EVAP control system pressure sensor harness connector.

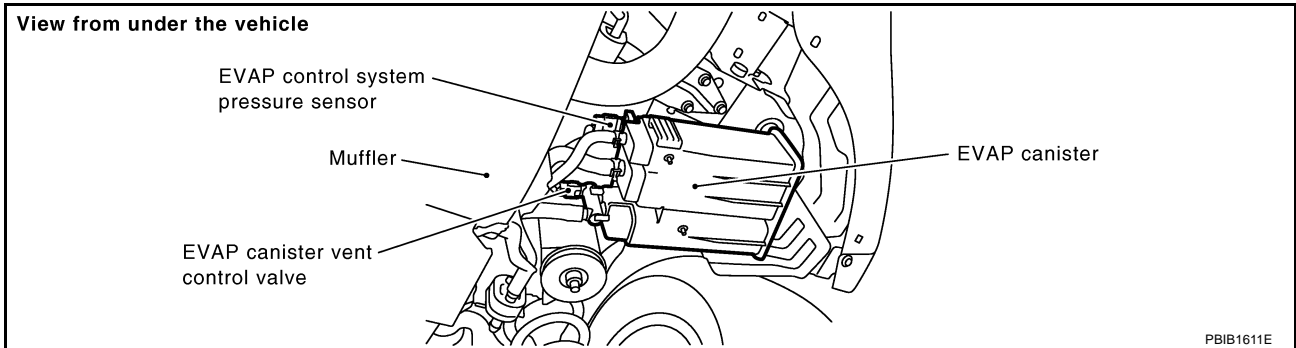

2. Check sensor harness connector for water.

Water should not exist.

OK or NG

- OK >> GO TO 3.
- NG >> Repair or replace harness connector.

3. CHECK EVAP CONTROL SYSTEM PRESSURE SENSOR

Refer to [EC-351, "Component Inspection"](#) .

OK or NG

- OK >> GO TO 4.
- NG >> Replace EVAP control system pressure sensor.

4. CHECK INTERMITTENT INCIDENT

Refer to [EC-135, "TROUBLE DIAGNOSIS FOR INTERMITTENT INCIDENT"](#) .

For Wiring Diagram, refer to [EC-354](#) .

>> INSPECTION END

Component Inspection EVAP CONTROL SYSTEM PRESSURE SENSOR

ABS009VZ

1. Remove EVAP control system pressure sensor with its harness connector connected from EVAP canister.
Do not reuse the O-ring, replace it with a new one.
2. Install a vacuum pump to EVAP control system pressure sensor.
3. Turn ignition switch ON and check output voltage between ECM terminal 32 and ground under the following conditions.

Applied vacuum kPa (mmHg, inHg)	Voltage V
Not applied	1.8 - 4.8
-26.7 (-200, -7.87)	2.1 to 2.5V lower than above value

CAUTION:

- Always calibrate the vacuum pump gauge when using it.
 - Do not apply below -93.3 kPa (-700 mmHg, -27.56 inHg) or pressure over 101.3 kPa (760 mmHg, 29.92 inHg).
4. If NG, replace EVAP control system pressure sensor.

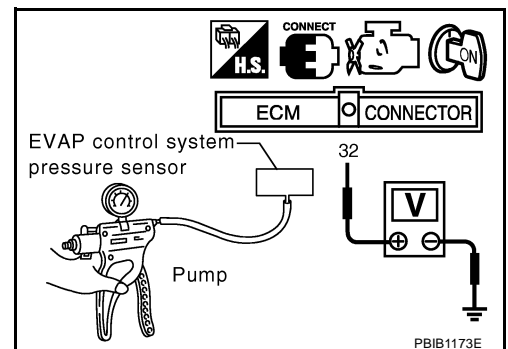

DTC P0452 EVAP CONTROL SYSTEM PRESSURE SENSOR

[VQ35DE]

DTC P0452 EVAP CONTROL SYSTEM PRESSURE SENSOR

PFV:25085

Component Description

ABS006R8

The EVAP control system pressure sensor detects pressure in the purge line. The sensor output voltage to the ECM increases as pressure increases.

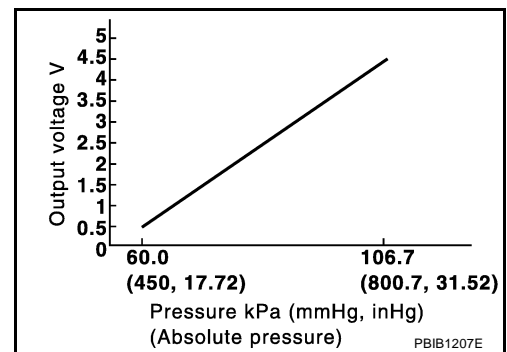
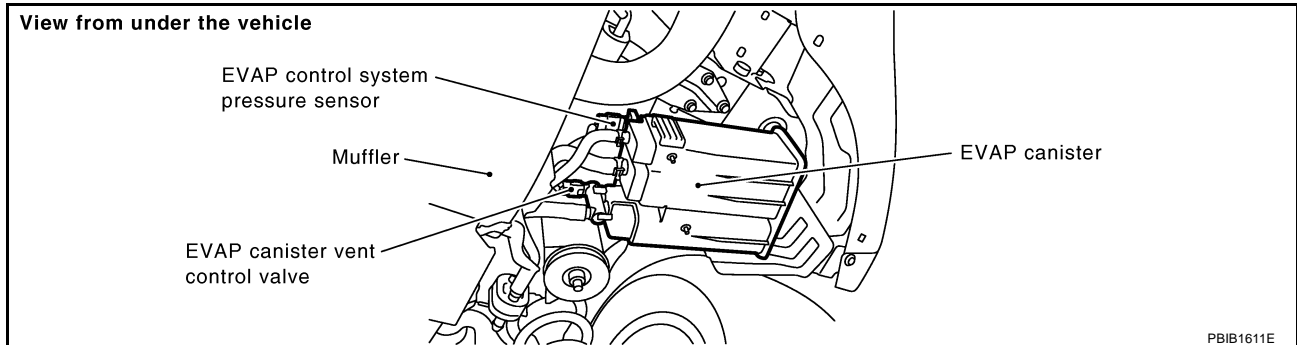

CONSULT-II Reference Value in Data Monitor Mode

ABS006R9

Specification data are reference values.

MONITOR ITEM	CONDITION	SPECIFICATION
EVAP SYS PRES	● Ignition switch: ON	Approx. 1.8 - 4.8V

On Board Diagnosis Logic

ABS006RA

NOTE:

If DTC P0452 is displayed with DTC P1229, first perform the trouble diagnosis for DTC P1229, Refer to [EC-489, "DTC P1229 SENSOR POWER SUPPLY"](#).

DTC No.	Trouble diagnosis name	DTC detecting condition	Possible cause
P0452 0452	EVAP control system pressure sensor low input	An excessively low voltage from the sensor is sent to ECM.	<ul style="list-style-type: none"> ● Harness or connectors (The sensor circuit is open or shorted.) ● EVAP control system pressure sensor

DTC Confirmation Procedure

NOTE:

If DTC Confirmation Procedure has been previously conducted, always turn ignition switch OFF and wait at least 10 seconds before conducting the next test.

TESTING CONDITION:

Always perform test at a temperature of 5°C (41°F) or more.

WITH CONSULT-II

1. Start engine and warm it up to normal operating temperature.
2. Turn ignition switch OFF and wait at least 10 seconds.
3. Turn ignition switch ON.
4. Select "DATA MONITOR" mode with CONSULT-II.
5. Make sure that "FUEL T/TEMP SE" is more than 0°C (32°F).
6. Start engine and wait at least 20 seconds.
If 1st trip DTC is detected, go to [EC-355, "Diagnostic Procedure"](#)

DATA MONITOR	
MONITOR	NO DTC
ENG SPEED	XXX rpm
COOLAN TEMP/S	XXX °C
FUEL T/TMP SE	XXX °C

SEF194Y

WITH GST

1. Start engine and warm it up to normal operating temperature.
2. Check that voltage between ECM terminal 107 (Fuel tank temperature sensor signal) and ground is less than 4.2V.
3. Turn ignition switch OFF and wait at least 10 seconds.
4. Start engine and wait at least 20 seconds.
5. Select MODE 7 with GST.
If 1st trip DTC is detected, go to [EC-355, "Diagnostic Procedure"](#)

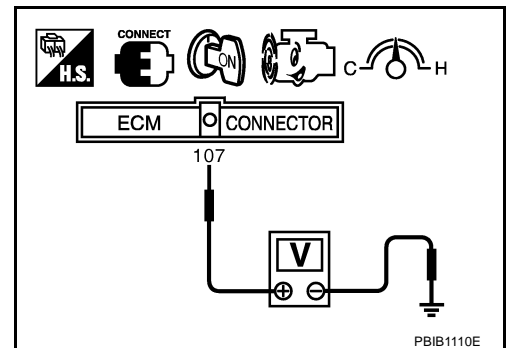

DTC P0452 EVAP CONTROL SYSTEM PRESSURE SENSOR

[VQ35DE]

Wiring Diagram

ABS006RC

EC-PRE/SE-01

: DETECTABLE LINE FOR DTC
 : NON-DETECTABLE LINE FOR DTC

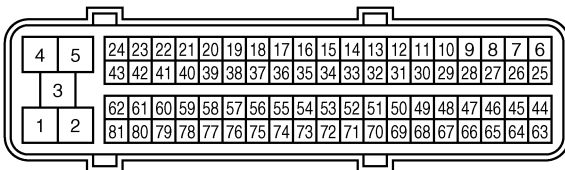
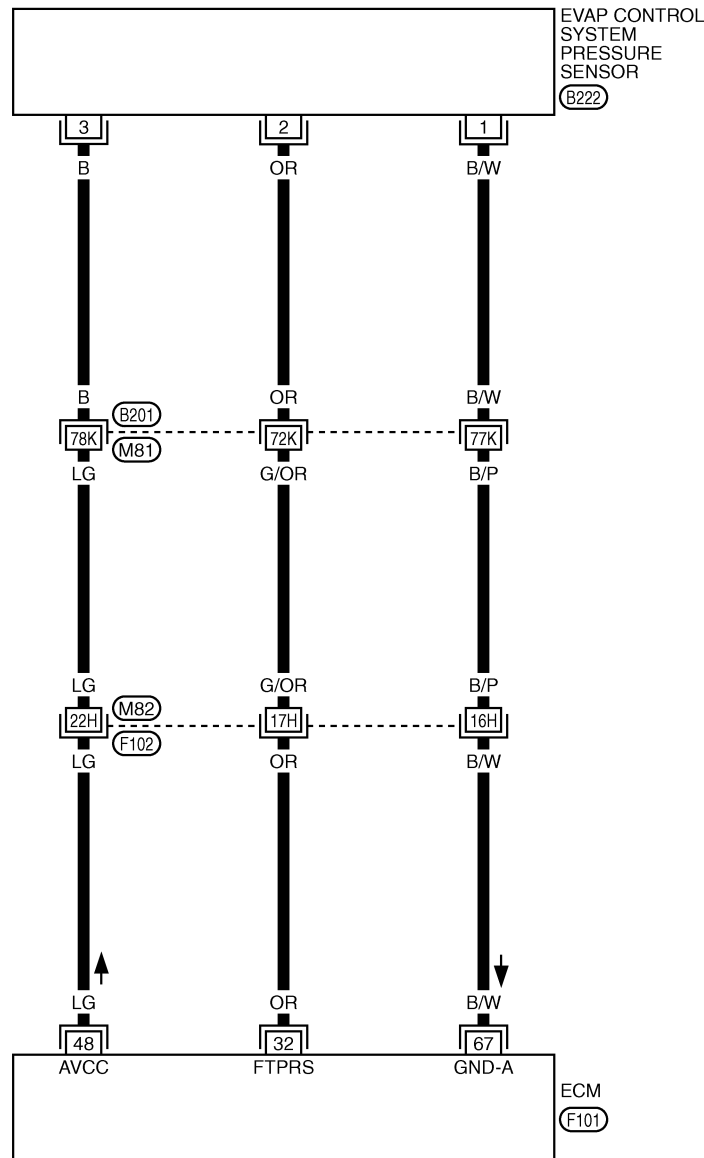

F101 B



3 2 1 B222 GY

REFER TO THE FOLLOWING.

(F102), (B201) -SUPER MULTIPLE JUNCTION (SMJ)

TBWH0111E

DTC P0452 EVAP CONTROL SYSTEM PRESSURE SENSOR

[VQ35DE]

Specification data are reference values and are measured between each terminal and ground.

CAUTION:

Do not use ECM ground terminals when measuring input/output voltage. Doing so may result in damage to the ECM's transistor. Use a ground other than ECM terminals, such as the ground.

TER-MINAL NO.	WIRE COLOR	ITEM	CONDITION	DATA (DC Voltage)
32	OR	EVAP control system pressure sensor	[Ignition switch: ON]	Approximately 1.8 - 4.8V
48	LG	Sensor power supply (EVAP control system pressure sensor)	[Ignition switch: ON]	Approximately 5V
67	B/W	Sensor ground (EVAP control system pressure sensor)	[Engine is running] ● Warm-up condition ● Idle speed	Approximately 0V

Diagnostic Procedure

ABS00CHJ

1. CHECK GROUND CONNECTIONS

1. Turn ignition switch OFF.
2. Loosen and retighten ground three screws on the body. Refer to [EC-141, "Ground Inspection"](#).

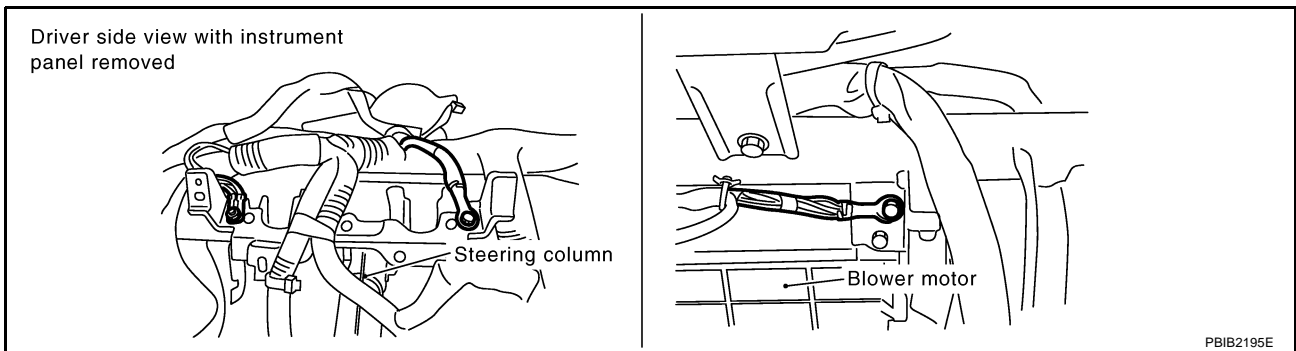

OK or NG

- OK >> GO TO 2.
- NG >> Repair or replace ground connections.

2. CHECK CONNECTOR

1. Disconnect EVAP control system pressure sensor harness connector.

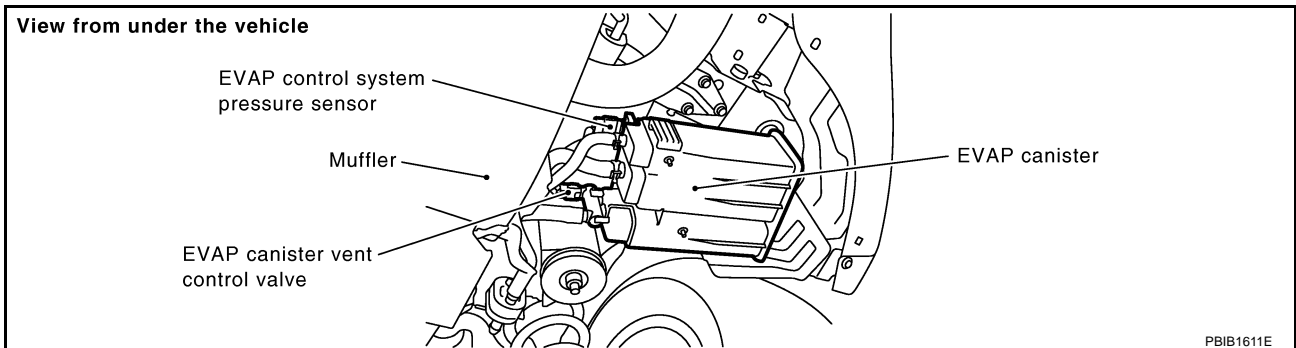

2. Check sensor harness connector for water.

Water should not exist.

OK or NG

- OK >> GO TO 3.
- NG >> Repair or replace harness connector.

3. CHECK EVAP CONTROL SYSTEM PRESSURE SENSOR POWER SUPPLY CIRCUIT

1. Turn ignition switch ON.
2. Check voltage between EVAP control system pressure sensor terminal 3 and ground with CONSULT-II or tester.

Voltage: Approximately 5V

OK or NG

- OK >> GO TO 5.
NG >> GO TO 4.

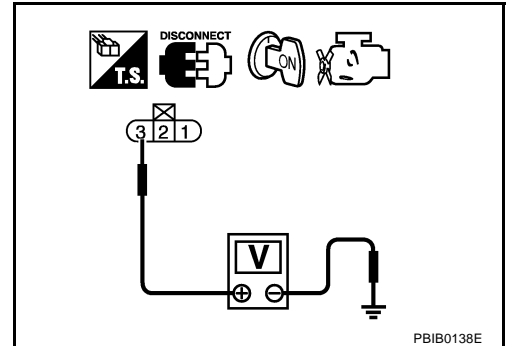

4. DETECT MALFUNCTIONING PART

Check the following.

- Harness connectors B201, M81
- Harness connectors M82, F102
- Harness for open or short between EVAP control system pressure sensor and ECM

>> Repair open circuit or short to ground or short to power in harness or connectors.

5. CHECK EVAP CONTROL SYSTEM PRESSURE SENSOR GROUND CIRCUIT FOR OPEN AND SHORT

1. Turn ignition switch OFF.
2. Disconnect ECM harness connector.
3. Check harness continuity between EVAP control system pressure sensor terminal 1 and ECM terminal 67.
Refer to Wiring Diagram.

Continuity should exist.

4. Also check harness for short to ground and short to power.

OK or NG

- OK >> GO TO 7.
NG >> GO TO 6.

6. DETECT MALFUNCTIONING PART

Check the following.

- Harness connectors B201, M81
- Harness connectors M82, F102
- Harness for open or short between EVAP control system pressure sensor and ECM

>> Repair open circuit or short to ground or short to power in harness or connectors.

7. CHECK EVAP CONTROL SYSTEM PRESSURE SENSOR INPUT SIGNAL CIRCUIT FOR OPEN AND SHORT

1. Check harness continuity between ECM terminal 32 and EVAP control system pressure sensor terminal 2.
2. Refer to Wiring Diagram.

Continuity should exist.

2. Also check harness for short to ground and short to power.

OK or NG

- OK >> GO TO 9.
- NG >> GO TO 8.

8. DETECT MALFUNCTIONING PART

Check the following.

- Harness connectors B201, M81
- Harness connectors M82, F102
- Harness for open or short between EVAP control system pressure sensor and ECM

>> Repair open circuit or short to ground or short to power in harness or connectors.

9. CHECK EVAP CONTROL SYSTEM PRESSURE SENSOR

Refer to [EC-357, "Component Inspection"](#) .

OK or NG

- OK >> GO TO 10.
- NG >> Replace EVAP control system pressure sensor.

10. CHECK INTERMITTENT INCIDENT

Refer to [EC-135, "TROUBLE DIAGNOSIS FOR INTERMITTENT INCIDENT"](#) .

>> **INSPECTION END**

Component Inspection EVAP CONTROL SYSTEM PRESSURE SENSOR

ABS006RE

1. Remove EVAP control system pressure sensor with its harness connector connected from EVAP canister.
Do not reuse the O-ring, replace it with a new one.
2. Install a vacuum pump to EVAP control system pressure sensor.
3. Turn ignition switch ON and check output voltage between ECM terminal 32 and ground under the following conditions.

Applied vacuum kPa (mmHg, inHg)	Voltage V
Not applied	1.8 - 4.8
-26.7 (-200, -7.87)	2.1 to 2.5V lower than above value

CAUTION:

- Always calibrate the vacuum pump gauge when using it.
 - Do not apply below -93.3 kPa (-700 mmHg, -27.56 inHg) or pressure over 101.3 kPa (760 mmHg, 29.92 inHg).
4. If NG, replace EVAP control system pressure sensor.

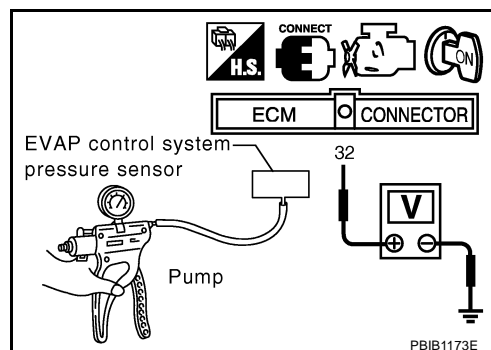

DTC P0453 EVAP CONTROL SYSTEM PRESSURE SENSOR

[VQ35DE]

DTC P0453 EVAP CONTROL SYSTEM PRESSURE SENSOR

PFP:25085

Component Description

ABS006RF

The EVAP control system pressure sensor detects pressure in the purge line. The sensor output voltage to the ECM increases as pressure increases.

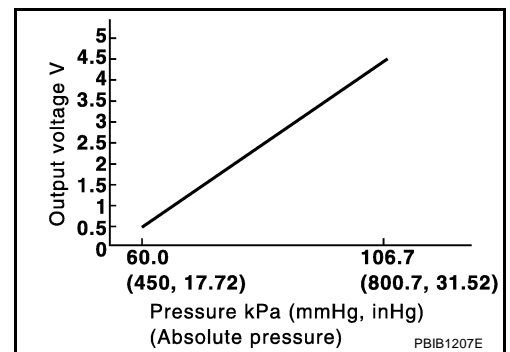
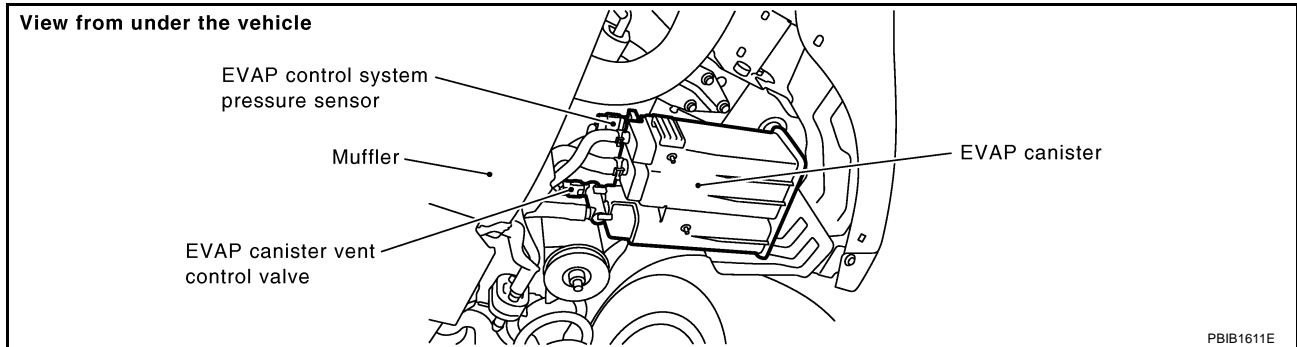

CONSULT-II Reference Value in Data Monitor Mode

ABS006RG

Specification data are reference values.

MONITOR ITEM	CONDITION	SPECIFICATION
EVAP SYS PRES	● Ignition switch: ON	Approx. 1.8 - 4.8V

On Board Diagnosis Logic

ABS006RH

NOTE:

If DTC P0453 is displayed with DTC P1229, first perform the trouble diagnosis for DTC P1229. Refer to [EC-489, "DTC P1229 SENSOR POWER SUPPLY"](#).

DTC No.	Trouble diagnosis name	DTC detecting condition	Possible cause
P0453 0453	EVAP control system pressure sensor high input	An excessively high voltage from the sensor is sent to ECM.	<ul style="list-style-type: none"> ● Harness or connectors (The sensor circuit is open or shorted.) ● EVAP control system pressure sensor ● EVAP canister vent control valve ● EVAP canister ● Rubber hose from EVAP canister vent control valve to vehicle frame

DTC Confirmation Procedure

NOTE:

If DTC Confirmation Procedure has been previously conducted, always turn ignition switch OFF and wait at least 10 seconds before conducting the next test.

TESTING CONDITION:

Always perform test at a temperature of 5°C (41°F) or more.

WITH CONSULT-II

1. Start engine and warm it up to normal operating temperature.
2. Turn ignition switch OFF and wait at least 10 seconds.
3. Turn ignition switch ON.
4. Select "DATA MONITOR" mode with CONSULT-II.
5. Make sure that "FUEL T/TEMP SE" is more than 0°C (32°F).
6. Wait at least 10 seconds.
7. If 1st trip DTC is detected, go to [EC-361, "Diagnostic Procedure"](#)

DATA MONITOR	
MONITOR	NO DTC
ENG SPEED	XXX rpm
COOLAN TEMP/S	XXX °C
FUEL T/TMP SE	XXX °C

SEF194Y

WITH GST

1. Start engine and warm it up to normal operating temperature.
 2. Check that voltage between ECM terminal 107 (Fuel tank temperature sensor signal) and ground is less than 4.2V.
 3. Turn ignition switch OFF and wait at least 10 seconds.
 4. Wait at least 10 seconds.
 5. Select MODE 7 with GST.
- If 1st trip DTC is detected, go to [EC-361, "Diagnostic Procedure"](#)

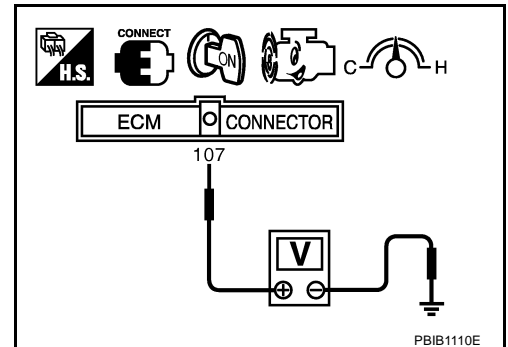

DTC P0453 EVAP CONTROL SYSTEM PRESSURE SENSOR

[VQ35DE]

Wiring Diagram

ABS006RJ

EC-PRE/SE-01

: DETECTABLE LINE FOR DTC
 : NON-DETECTABLE LINE FOR DTC

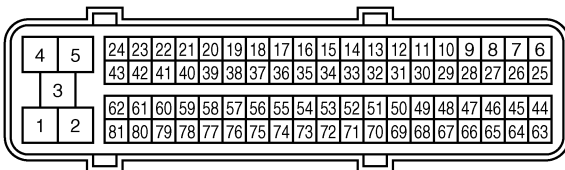
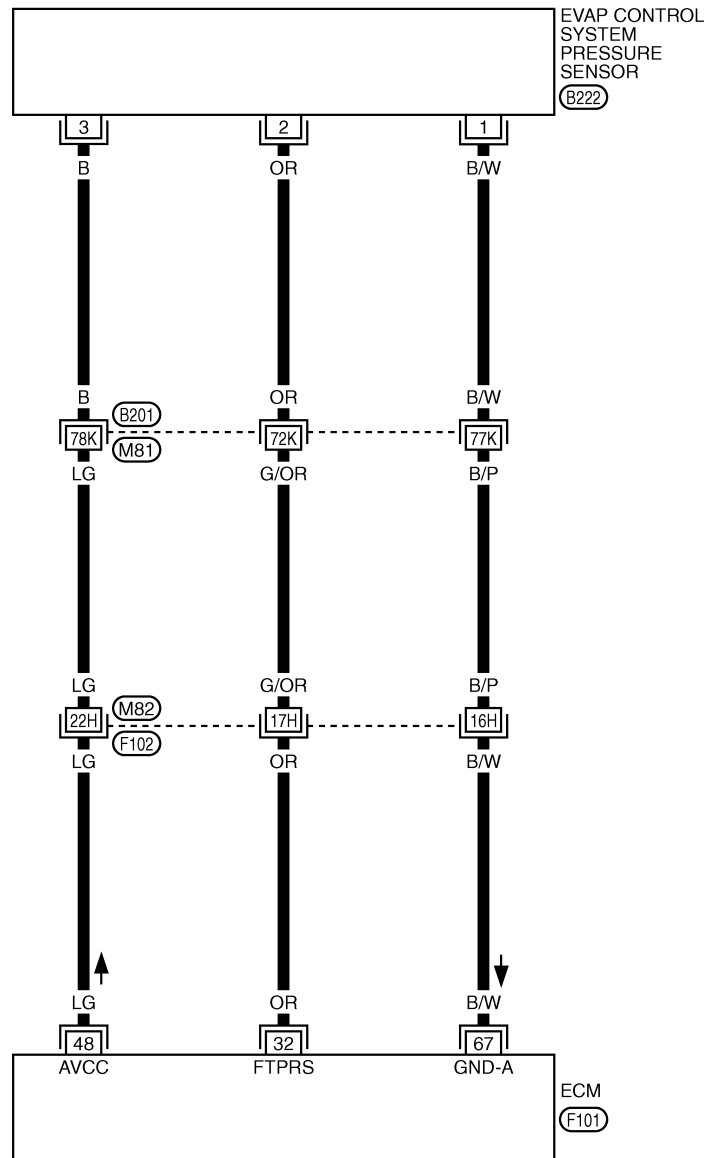

F101
B



3 2 1 B222
GY

REFER TO THE FOLLOWING.

(F102), (B201) -SUPER MULTIPLE JUNCTION (SMJ)

TBWH0111E

Specification data are reference values and are measured between each terminal and ground.

CAUTION:

Do not use ECM ground terminals when measuring input/output voltage. Doing so may result in damage to the ECM's transistor. Use a ground other than ECM terminals, such as the ground.

TER-MINAL NO.	WIRE COLOR	ITEM	CONDITION	DATA (DC Voltage)
32	OR	EVAP control system pressure sensor	[Ignition switch: ON]	Approximately 1.8 - 4.8V
48	LG	Sensor power supply (EVAP control system pressure sensor)	[Ignition switch: ON]	Approximately 5V
67	B/W	Sensor ground (EVAP control system pressure sensor 1)	[Engine is running] ● Warm-up condition ● Idle speed	Approximately 0V

Diagnostic Procedure

ABS00CHK

1. CHECK GROUND CONNECTIONS

1. Turn ignition switch OFF.
2. Loosen and retighten ground three screws on the body. Refer to [EC-141, "Ground Inspection"](#).

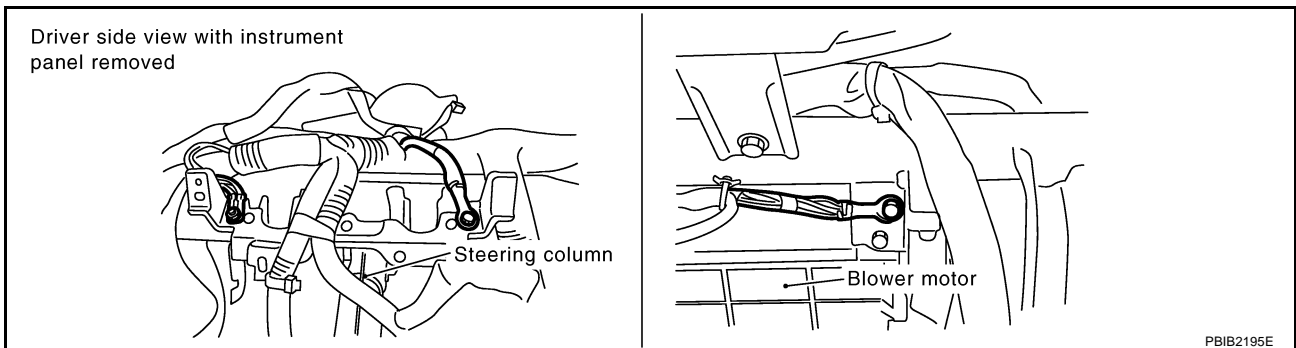

OK or NG

- OK >> GO TO 2.
- NG >> Repair or replace ground connections.

2. CHECK CONNECTOR

1. Disconnect EVAP control system pressure sensor harness connector.

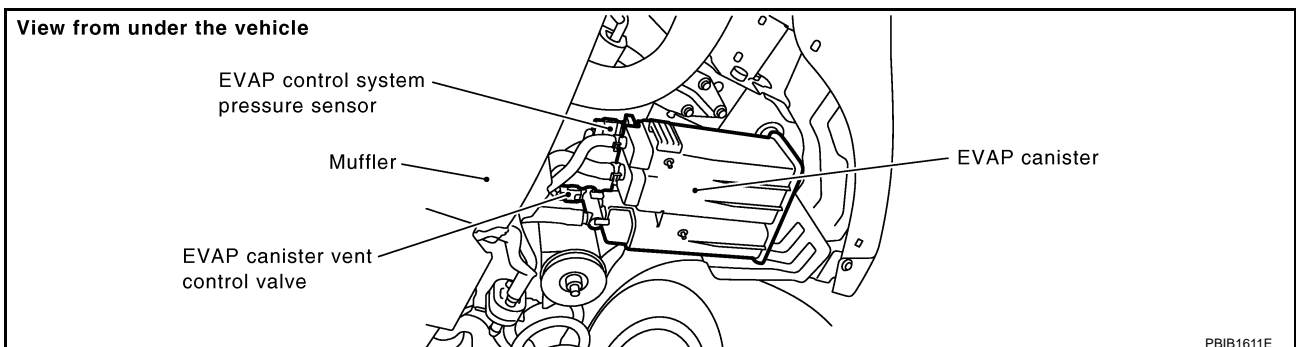

2. Check sensor harness connector for water.

Water should not exist.

OK or NG

- OK >> GO TO 3.
- NG >> Repair or replace harness connector.

3. CHECK EVAP CONTROL SYSTEM PRESSURE SENSOR POWER SUPPLY CIRCUIT

1. Turn ignition switch ON.
2. Check voltage between EVAP control system pressure sensor terminal 3 and ground with CONSULT-II or tester.

Voltage: Approximately 5V

OK or NG

- OK >> GO TO 5.
NG >> GO TO 4.

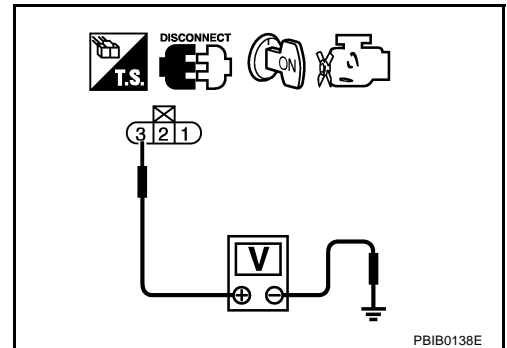

4. DETECT MALFUNCTIONING PART

Check the following.

- Harness connectors M81, B201
- Harness connectors M82, F102
- Harness for open or short between EVAP control system pressure sensor and ECM

>> Repair open circuit or short to ground or short to power in harness or connectors.

5. CHECK EVAP CONTROL SYSTEM PRESSURE SENSOR GROUND CIRCUIT FOR OPEN AND SHORT

1. Turn ignition switch OFF.
2. Disconnect ECM harness connector.
3. Check harness continuity between EVAP control system pressure sensor terminal 1 and ECM terminal 67.
Refer to Wiring Diagram.

Continuity should exist.

4. Also check harness for short to ground and short to power.

OK or NG

- OK >> GO TO 7.
NG >> GO TO 6.

6. DETECT MALFUNCTIONING PART

Check the following.

- Harness connectors M81, B201
- Harness connectors M82, F102
- Harness for open or short between EVAP control system pressure sensor and ECM

>> Repair open circuit or short to ground or short to power in harness or connectors.

7. CHECK EVAP CONTROL SYSTEM PRESSURE SENSOR INPUT SIGNAL CIRCUIT FOR OPEN AND SHORT

1. Check harness continuity between ECM terminal 32 and EVAP control system pressure sensor terminal 2.
2. Refer to Wiring Diagram.

Continuity should exist.

2. Also check harness for short to ground and short to power.

OK or NG

- OK >> GO TO 9.
NG >> GO TO 8.

8. DETECT MALFUNCTIONING PART

Check the following.

- Harness connectors M81, B201
- Harness connectors M82, F102
- Harness for open or short between EVAP control system pressure sensor and ECM

>> Repair open circuit or short to ground or short to power in harness or connectors.

9. CHECK RUBBER TUBE

1. Disconnect rubber tube connected to EVAP canister vent control valve.
2. Check the rubber tube for clogging, vent and kinked.

OK or NG

- OK >> GO TO 10.
NG >> Clean the rubber tube using an air blower, repair or replace rubber tube.

10. CHECK EVAP CANISTER VENT CONTROL VALVE

Refer to [EC-347, "Component Inspection"](#) .

OK or NG

- OK >> GO TO 11.
NG >> Replace EVAP canister vent control valve.

11. CHECK EVAP CONTROL SYSTEM PRESSURE SENSOR

Refer to [EC-365, "Component Inspection"](#) .

OK or NG

- OK >> GO TO 12.
NG >> Replace EVAP control system pressure sensor.

12. CHECK IF EVAP CANISTER SATURATED WITH WATER

1. Remove EVAP canister with EVAP canister vent control valve and EVAP control system pressure sensor attached.
2. Check if water will drain from the EVAP canister.

Yes or No

Yes >> GO TO 13.

No >> GO TO 15.

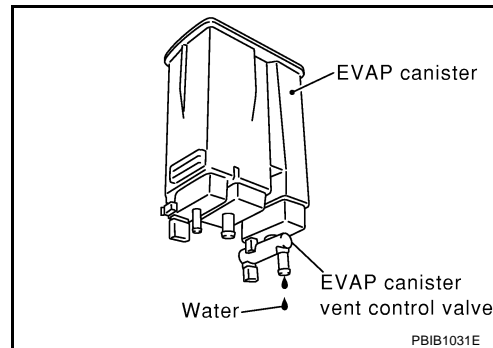

13. CHECK EVAP CANISTER

Weigh the EVAP canister with the EVAP canister vent control valve and EVAP control system pressure sensor attached.

The weight should be less than 2.1 kg (4.6 lb).

OK or NG

OK >> GO TO 15.

NG >> GO TO 14.

14. DETECT MALFUNCTIONING PART

Check the following.

- EVAP canister for damage
- EVAP hose between EVAP canister and vehicle frame for clogging or poor connection

>> Repair hose or replace EVAP canister.

15. CHECK INTERMITTENT INCIDENT

Refer to [EC-135, "TROUBLE DIAGNOSIS FOR INTERMITTENT INCIDENT"](#) .

>> INSPECTION END

DTC P0453 EVAP CONTROL SYSTEM PRESSURE SENSOR

[VQ35DE]

ABS006RL

Component Inspection

EVAP CONTROL SYSTEM PRESSURE SENSOR

1. Remove EVAP control system pressure sensor with its harness connector connected from EVAP canister.
Always replace O-ring with a new one.
2. Install a vacuum pump to EVAP control system pressure sensor.
3. Turn ignition switch ON and check output voltage between ECM terminal 32 and ground under the following conditions.

Applied vacuum kPa (mmHg, inHg)	Voltage V
Not applied	1.8 - 4.8
-26.7 (-200, -7.87)	2.1 to 2.5V lower than above value

CAUTION:

- Always calibrate the vacuum pump gauge when using it.
 - Do not apply below -93.3 kPa (-700 mmHg, -27.56 inHg) or pressure over 101.3 kPa (760 mmHg, 29.92 inHg).
4. If NG, replace EVAP control system pressure sensor.

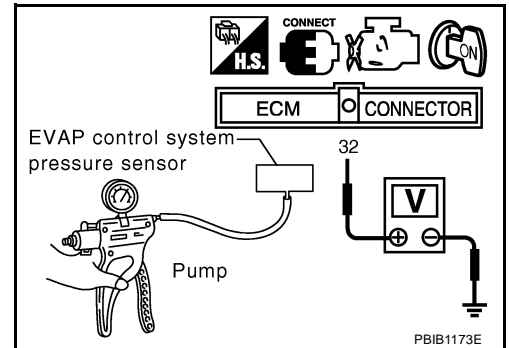

A

EC

C

D

E

F

G

H

I

J

K

L

M

DTC P0455 EVAP CONTROL SYSTEM

PFP:14950

On Board Diagnosis Logic

ABS006RM

This diagnosis detects a very large leak (fuel filler cap fell off etc.) in EVAP system between the fuel tank and EVAP canister purge volume control solenoid valve.

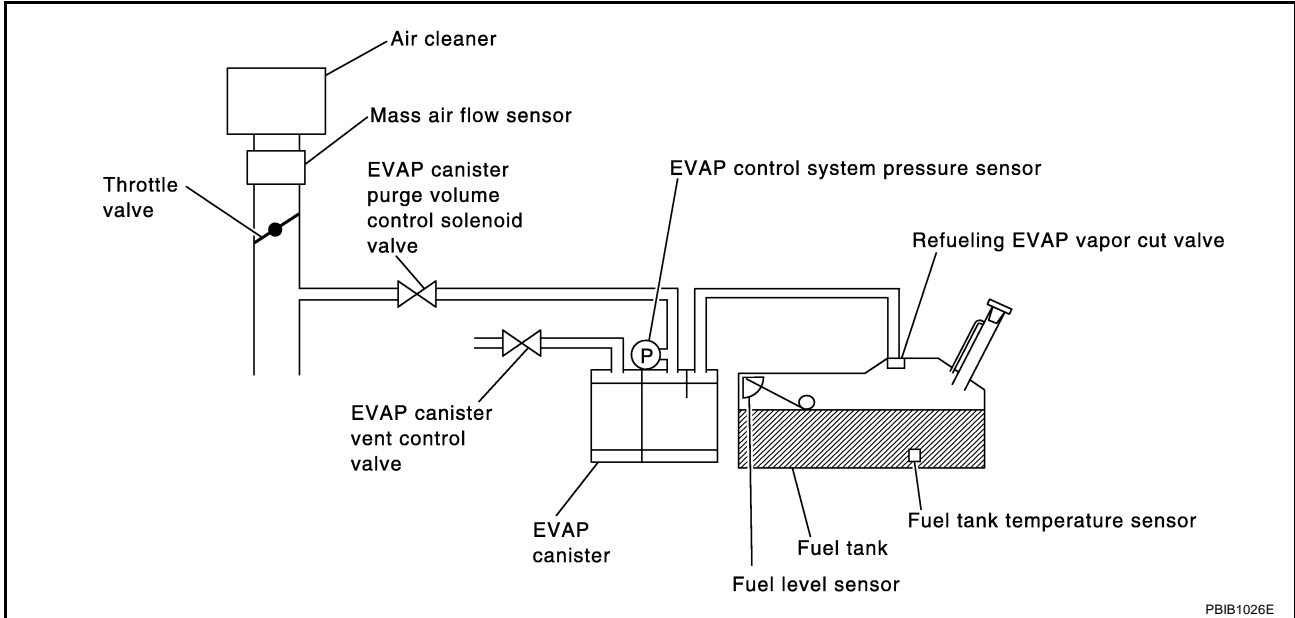

DTC No.	Trouble diagnosis name	DTC detecting condition	Possible cause
P0455 0455	EVAP control system gross leak detected	EVAP control system has a very large leak such as fuel filler cap fell off, EVAP control system does not operate properly.	<ul style="list-style-type: none"> ● Fuel filler cap remains open or fails to close. ● Incorrect fuel tank vacuum relief valve ● Incorrect fuel filler cap used ● Foreign matter caught in fuel filler cap. ● Leak is in line between intake manifold and EVAP canister purge volume control solenoid valve. ● Foreign matter caught in EVAP canister vent control valve. ● EVAP canister or fuel tank leaks ● EVAP purge line (pipe and rubber tube) leaks ● EVAP purge line rubber tube bent. ● Loose or disconnected rubber tube ● EVAP canister vent control valve and the circuit ● EVAP canister purge volume control solenoid valve and the circuit ● Fuel tank temperature sensor ● O-ring of EVAP canister vent control valve is missing or damaged. ● EVAP control system pressure sensor ● Refueling EVAP vapor cut valve ● ORVR system leaks

CAUTION:

- Use only a genuine NISSAN fuel filler cap as a replacement. If an incorrect fuel filler cap is used, the MIL may come on.
- If the fuel filler cap is not tightened properly, the MIL may come on.

- Use only a genuine NISSAN rubber tube as a replacement.

DTC Confirmation Procedure

ABS006RN

CAUTION:

Never remove fuel filler cap during the DTC Confirmation Procedure.

NOTE:

- Make sure that EVAP hoses are connected to EVAP canister purge volume control solenoid valve properly.
- If DTC Confirmation Procedure has been previously conducted, always turn ignition switch OFF and wait at least 10 seconds before conducting the next test.

TESTING CONDITION:

- Perform "DTC WORK SUPPORT" when the fuel level is between 1/4 and 3/4 full and vehicle is placed on flat level surface.
- Open engine hood before conducting the following procedures.

WITH CONSULT-II

1. Tighten fuel filler cap securely until ratcheting sound is heard.
2. Turn ignition switch ON.
3. Turn ignition switch OFF and wait at least 10 seconds.
4. Turn ignition switch ON and select "DATA MONITOR" mode with CONSULT-II.
5. Make sure that the following conditions are met.
COOLAN TEMP/S: 0 - 70°C (32 - 158°F)
INT/A TEMP SE: 0 - 60°C (32 - 140°F)
6. Select "EVAP SML LEAK P0442/P1442" of "EVAPORATIVE SYSTEM" in "DTC WORK SUPPORT" mode with CONSULT-II.
 Follow the instruction displayed.

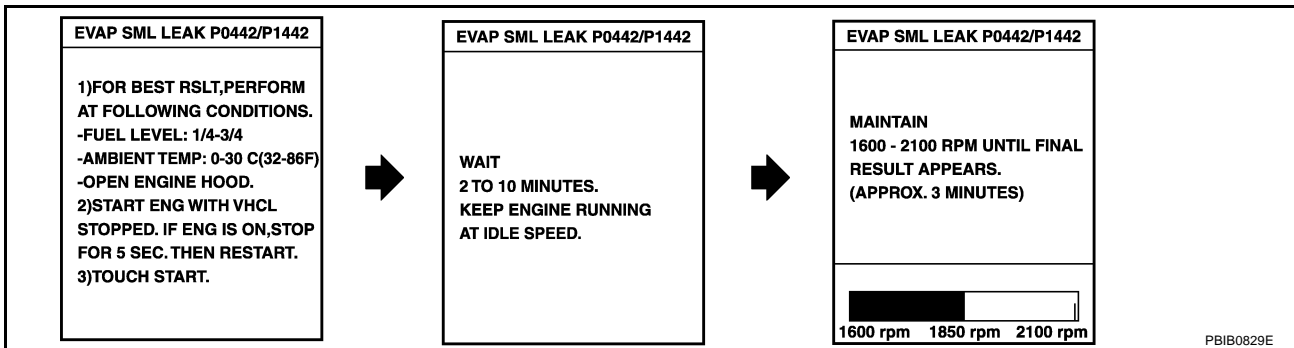

NOTE:

If the engine speed cannot be maintained within the range displayed on the CONSULT-II screen, go to [EC-83, "Basic Inspection"](#).

7. Make sure that "OK" is displayed.
 If "NG" is displayed, select "SELF-DIAG RESULTS" mode and make sure that "EVAP GROSS LEAK [P0455]" is displayed. If it is displayed, refer to [EC-368, "Diagnostic Procedure"](#).
 If P0442 is displayed, perform Diagnostic Procedure for DTC P0442 [EC-328, "Diagnostic Procedure"](#).

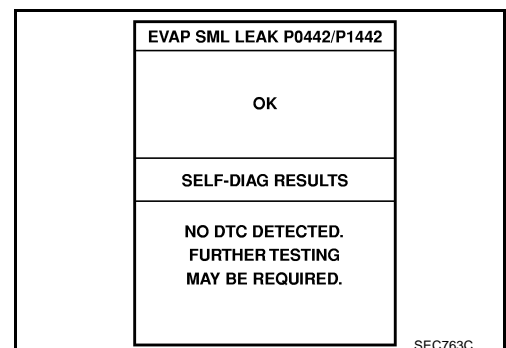

WITH GST**NOTE:**

Be sure to read the explanation of [EC-64, "Driving Pattern"](#) before driving vehicle.

1. Start engine.
2. Drive vehicle according to [EC-64, "Driving Pattern"](#) .
3. Stop vehicle.
4. Turn ignition switch OFF, wait at least 10 seconds and then turn ON.
5. Select MODE 7 with GST.
 - If P0455 is displayed on the screen, go to [EC-368, "Diagnostic Procedure"](#) .
 - If P0442 is displayed on the screen, go to Diagnostic Procedure, for DTC P0442, [EC-328](#) .
 - If P0441 is displayed on the screen, go to Diagnostic Procedure for DTC P0441, [EC-323](#) .

Diagnostic Procedure

ABS006R0

1. CHECK FUEL FILLER CAP DESIGN

1. Turn ignition switch OFF.
2. Check for genuine NISSAN fuel filler cap design.

OK or NG

- OK >> GO TO 2.
 NG >> Replace with genuine NISSAN fuel filler cap.

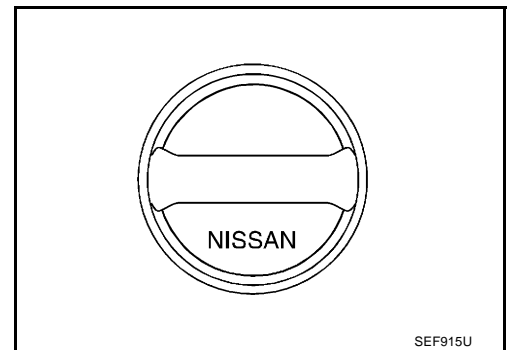
**2. CHECK FUEL FILLER CAP INSTALLATION**

Check that the cap is tightened properly by rotating the cap clockwise.

OK or NG

- OK >> GO TO 3.
 NG >> 1. Open fuel filler cap, then clean cap and fuel filler neck threads using air blower.
 2. Retighten until ratcheting sound is heard.

3. CHECK FUEL FILLER CAP FUNCTION

Check for air releasing sound while opening the fuel filler cap.

OK or NG

- OK >> GO TO 5.
 NG >> GO TO 4.

4. CHECK FUEL TANK VACUUM RELIEF VALVE

Refer to [EC-646, "FUEL TANK VACUUM RELIEF VALVE \(BUILT INTO FUEL FULLER CAP\)"](#) .

OK or NG

- OK >> GO TO 5.
 NG >> Replace fuel filler cap with a genuine one.

5. CHECK EVAP PURGE LINE

Check EVAP purge line (pipe, rubber tube, fuel tank and EVAP canister) for cracks, improper connection or disconnection.

Refer to [EC-644, "EVAPORATIVE EMISSION LINE DRAWING"](#).

OK or NG

OK >> GO TO 6.

NG >> Repair or reconnect the hose.

6. CLEAN EVAP PURGE LINE

Clean EVAP purge line (pipe and rubber tube) using air blower.

>> GO TO 7.

7. CHECK EVAP CANISTER VENT CONTROL VALVE

Check the following.

- EVAP canister vent control valve is installed properly.
Refer to [EC-647, "Removal and Installation"](#).
- EVAP canister vent control valve.
Refer to [EC-347, "Component Inspection"](#).

OK or NG

OK >> GO TO 8.

NG >> Repair or replace EVAP canister vent control valve and O-ring.

8. INSTALL THE PRESSURE PUMP

To locate the EVAP leak, install EVAP service port adapter and pressure pump to EVAP service port securely.

NOTE:

Improper installation of the EVAP service port adapter to the EVAP service port may cause leaking.

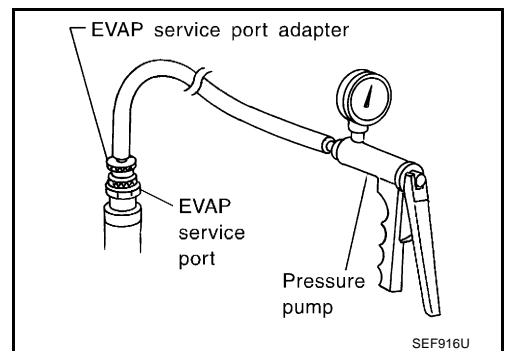
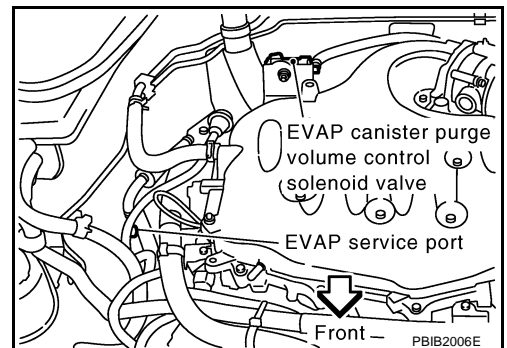

Models with CONSULT-II >> GO TO 9.
Models without CONSULT-II >> GO TO 10.

9. CHECK FOR EVAP LEAK

④ With CONSULT-II

1. Turn ignition switch ON.
2. Select "EVAP SYSTEM CLOSE" of "WORK SUPPORT" mode with CONSULT-II.
3. Touch "START" and apply pressure into the EVAP line until the pressure indicator reaches the middle of the bar graph.

NOTE:

- Never use compressed air or a high pressure pump.
- Do not exceed 4.12 kPa (0.042 kg/cm² , 0.6 psi) of pressure in the system.

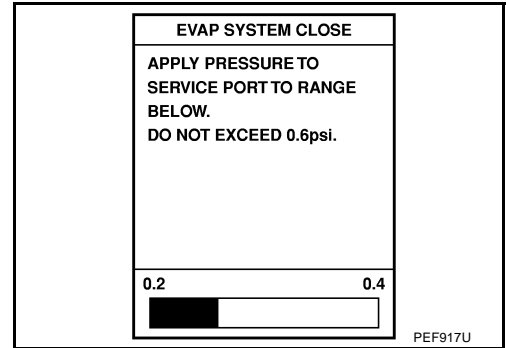

4. Using EVAP leak detector, locate the EVAP leak. For the leak detector, refer to the instruction manual for more details. Refer to [EC-644, "EVAPORATIVE EMISSION LINE DRAWING"](#)

OK or NG

- OK >> GO TO 11.
 NG >> Repair or replace.

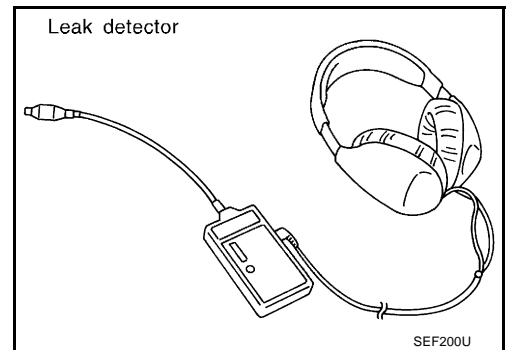

10. CHECK FOR EVAP LEAK

⊗ Without CONSULT-II

1. Turn ignition switch OFF.
2. Apply 12 volts DC to EVAP canister vent control valve. The valve will close. (Continue to apply 12 volts until the end of test.)

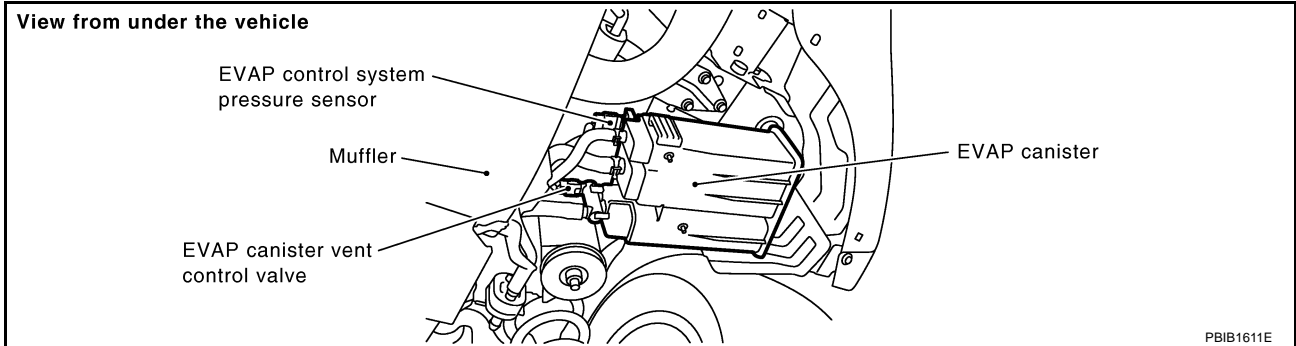

3. Pressurize the EVAP line using pressure pump with 1.3 to 2.7 kPa (10 to 20 mmHg, 0.39 to 0.79 inHg), then remove pump and EVAP service port adapter.

NOTE:

- Never use compressed air or a high pressure pump.
- Do not exceed 4.12 kPa (0.042 kg/cm², 0.6 psi) of pressure in the system.

4. Using EVAP leak detector, locate the EVAP leak. For the leak detector, refer to the instruction manual for more details. Refer to [EC-644, "EVAPORATIVE EMISSION LINE DRAWING"](#).

OK or NG

- OK >> GO TO 12.
 NG >> Repair or replace.

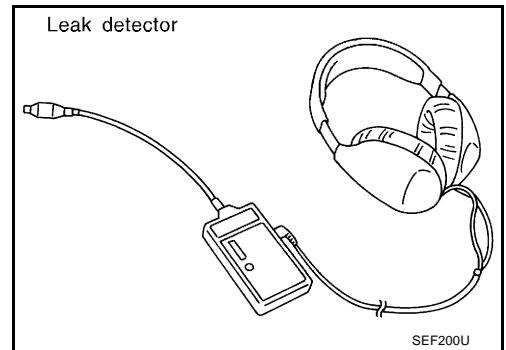

11. CHECK EVAP CANISTER PURGE VOLUME CONTROL SOLENOID VALVE OPERATION

Ⓟ With CONSULT-II

1. Disconnect vacuum hose to EVAP canister purge volume control solenoid valve at EVAP service port.
2. Start engine.
3. Perform "PURG VOL CONT/V" in "ACTIVE TEST" mode.
4. Touch "Qu" on CONSULT-II screen to increase "PURG VOL CONT/V" opening to 100%.
5. Check vacuum hose for vacuum when revving engine up to 2,000 rpm.

OK or NG

- OK >> GO TO 14.
 NG >> GO TO 13.

ACTIVE TEST	
PURG VOL CONT/V	XXX %
MONITOR	
ENG SPEED	XXX rpm
A/F ALPHA-B1	XX %
HO2S1 MNTR (B1)	LEAN

PBIB0828E

12. CHECK EVAP CANISTER PURGE VOLUME CONTROL SOLENOID VALVE OPERATION

⊗ Without CONSULT-II

1. Start engine and warm it up to normal operating temperature.
2. Stop engine.
3. Disconnect vacuum hose to EVAP canister purge volume control solenoid valve at EVAP service port.
4. Start engine and let it idle for at least 80 seconds.
5. Check vacuum hose for vacuum when revving engine up to 2,000 rpm.

Vacuum should exist.

OK or NG

- OK >> GO TO 15.
 NG >> GO TO 13.

13. CHECK VACUUM HOSE

Check vacuum hoses for clogging or disconnection. Refer to [EC-30, "Vacuum Hose Drawing"](#) .

OK or NG

- OK (With CONSULT-II)>>GO TO 14.
 OK (Without CONSULT-II)>>GO TO 15.
 NG >> Repair or reconnect the hose.

14. CHECK EVAP CANISTER PURGE VOLUME CONTROL SOLENOID VALVE

Ⓜ With CONSULT-II

1. Start engine.
2. Perform "PURG VOL CONT/V" in "ACTIVE TEST" mode with CONSULT-II. Check that engine speed varies according to the valve opening.

OK or NG

- OK >> GO TO 16.
 NG >> GO TO 15.

ACTIVE TEST	
PURG VOL CONT/V	XXX %
MONITOR	
ENG SPEED	XXX rpm
A/F ALPHA-B1	XX %
HO2S1 MNTR (B1)	LEAN

PBIB0628E

15. CHECK EVAP CANISTER PURGE VOLUME CONTROL SOLENOID VALVE

Refer to [EC-340, "Component Inspection"](#) .

OK or NG

- OK >> GO TO 16.
 NG >> Replace EVAP canister purge volume control solenoid valve.

16. CHECK FUEL TANK TEMPERATURE SENSOR

Refer to [EC-277, "Component Inspection"](#) .

OK or NG

- OK >> GO TO 17.
 NG >> Replace fuel level sensor unit.

17. CHECK EVAP CONTROL SYSTEM PRESSURE SENSOR

Refer to [EC-357, "Component Inspection"](#) .

OK or NG

- OK >> GO TO 18.
- NG >> Replace EVAP control system pressure sensor.

18. CHECK EVAP/ORVR LINE

Check EVAP/ORVR line between EVAP canister and fuel tank for clogging, kink, looseness and improper connection. For location, refer to [EC-650, "ON BOARD REFUELING VAPOR RECOVERY \(ORVR\)"](#) .

OK or NG

- OK >> GO TO 19.
- NG >> Repair or replace hoses and tubes.

19. CHECK RECIRCULATION LINE

Check recirculation line between filler neck tube and fuel tank for clogging, kink, cracks, looseness and improper connection.

OK or NG

- OK >> GO TO 20.
- NG >> Repair or replace hose, tube or filler neck tube.

20. CHECK REFUELING EVAP VAPOR CUT VALVE

Refer to [EC-653, "Component Inspection"](#) .

OK or NG

- OK >> GO TO 21.
- NG >> Replace refueling EVAP vapor cut valve with fuel tank.

21. CHECK INTERMITTENT INCIDENT

Refer to [EC-135, "TROUBLE DIAGNOSIS FOR INTERMITTENT INCIDENT"](#) .

>> **INSPECTION END**

A

EC

C

D

E

F

G

H

I

J

K

L

M

DTC P0456 EVAP CONTROL SYSTEM

PFP:14950

On Board Diagnosis Logic

ABS006RP

This diagnosis detects very small leaks in the EVAP line between fuel tank and EVAP canister purge volume control solenoid valve, using the intake manifold vacuum in the same way as conventional EVAP small leak diagnosis.

If ECM judges a leak which corresponds to a very small leak, the very small leak P0456 will be detected.

If ECM judges a leak equivalent to a small leak, EVAP small leak P0442 will be detected.

If ECM judges there are no leaks, the diagnosis will be OK.

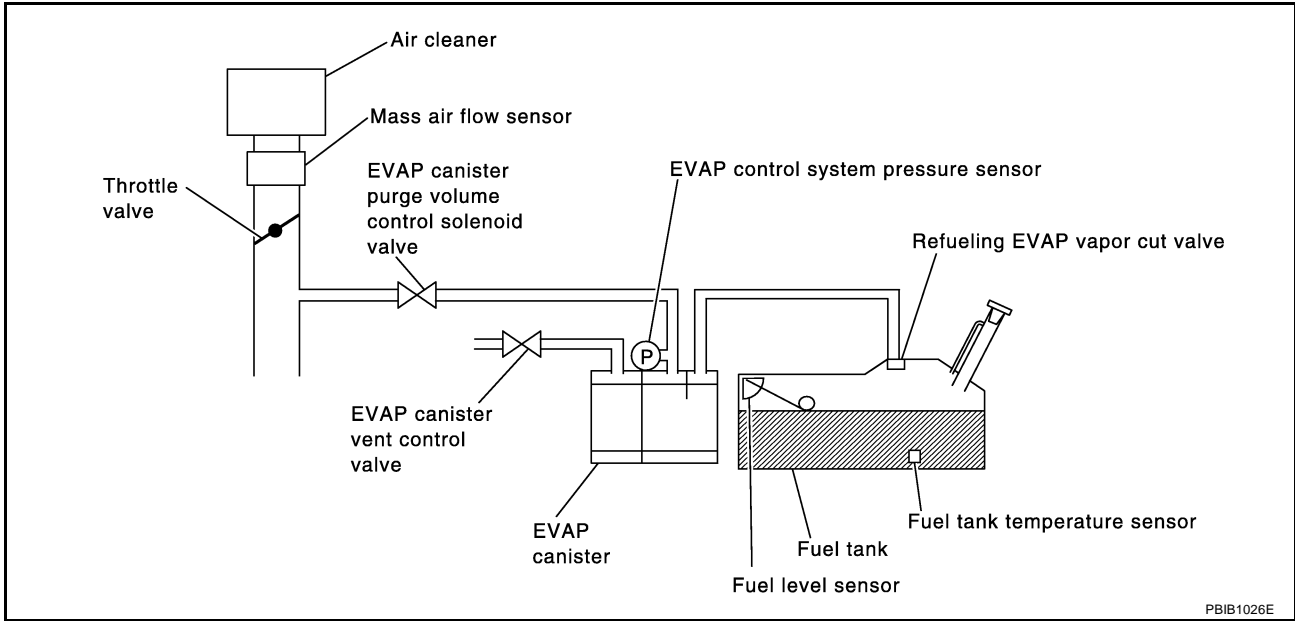

DTC No.	Trouble diagnosis name	DTC detecting condition	Possible cause
P0456 0456	Evaporative emission control system very small leak (negative pressure check)	<ul style="list-style-type: none"> ● EVAP system has a very small leak. ● EVAP system does not operate properly. 	<ul style="list-style-type: none"> ● Incorrect fuel tank vacuum relief valve ● Incorrect fuel filler cap used ● Fuel filler cap remains open or fails to close. ● Foreign matter caught in fuel filler cap. ● Leak is in line between intake manifold and EVAP canister purge volume control solenoid valve. ● Foreign matter caught in EVAP canister vent control valve. ● EVAP canister or fuel tank leaks ● EVAP purge line (pipe and rubber tube) leaks ● EVAP purge line rubber tube bent ● Loose or disconnected rubber tube ● EVAP canister vent control valve and the circuit ● EVAP canister purge volume control solenoid valve and the circuit ● Fuel tank temperature sensor ● O-ring of EVAP canister vent control valve is missing or damaged ● EVAP canister is saturated with water ● EVAP control system pressure sensor ● Refueling EVAP vapor cut valve ● ORVR system leaks ● Fuel level sensor and the circuit ● Foreign matter caught in EVAP canister purge volume control solenoid valve

CAUTION:

- Use only a genuine NISSAN fuel filler cap as a replacement. If an incorrect fuel filler cap is used, the MIL may come on. A
- If the fuel filler cap is not tightened properly, the MIL may come on.
- Use only a genuine NISSAN rubber tube as a replacement. EC

DTC Confirmation Procedure

ABS006RQ

NOTE:

- If DTC P0456 is displayed with P0442, first perform trouble diagnosis for DTC P0456. C
- After repair, make sure that the hoses and clips are installed properly.
- If DTC Confirmation Procedure has been previously conducted, always turn ignition switch OFF and wait at least 10 seconds before conducting the next test. D

TESTING CONDITION:

- Open engine hood before conducting following procedure. E
- If any of following conditions are met just before the DTC confirmation procedure, leave the vehicle for more than 1 hour. F
 - Fuel filler cap is removed.
 - Fuel is refilled or drained.
 - EVAP component parts is/are removed.
- Before performing the following procedure, confirm that battery voltage is more than 11V at idle. G

H

I

J

K

L

M

WITH CONSULT-II

1. Turn ignition switch ON and select "DATA MONITOR" mode with CONSULT-II.
2. Make sure the following conditions are met.
FUEL LEVEL SE: 0.25 - 1.4V
COOLAN TEMP/S: 0 - 32°C (32 - 90°F)
FUEL T/TMP SE: 0 - 35°C (32 - 95°F)
INT A/TEMP SE: More than 0°C (32°F)
 If NG, turn ignition switch OFF and leave the vehicle in a cool place (soak the vehicle) or refilling/draining fuel until the output voltage condition of the "FUEL LEVEL SE" meets within the range above and leave the vehicle for more than 1 hour. Then start from step 1).
3. Turn ignition switch OFF and wait at least 10 seconds.
4. Turn ignition switch ON.
5. Select "EVAP V/S LEAK P0456/P1456" of "EVAPORATIVE SYSTEM" in "DTC WORK SUPPORT" mode with CONSULT-II.
 Follow the instruction displayed.

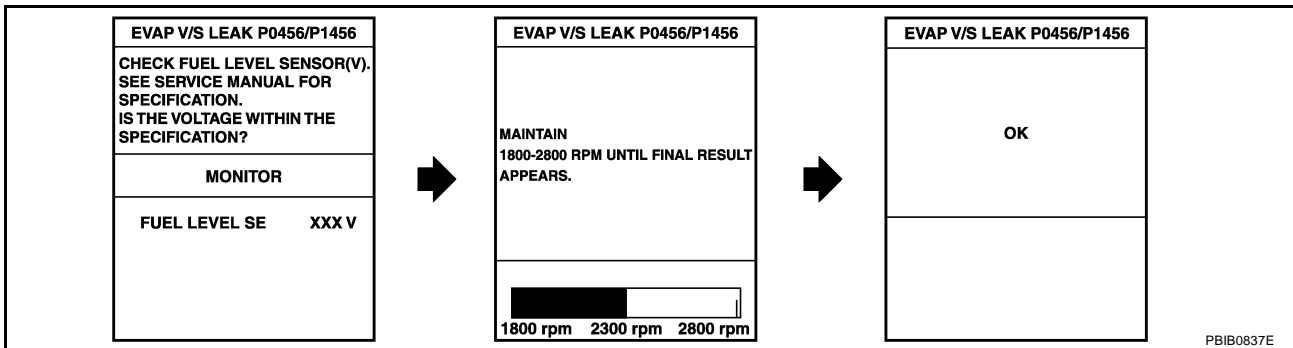

6. Make sure that "OK" is displayed.
 If "NG" is displayed, refer to [EC-377, "Diagnostic Procedure"](#).

NOTE:

- If the engine speed cannot be maintained within the range displayed on CONSULT-II screen, go to [EC-83, "Basic Inspection"](#).
- Make sure that EVAP hoses are connected to EVAP canister purge volume control solenoid valve properly.

Overall Function Check

ABS006RR

WITH GST

Use this procedure to check the overall function of the EVAP very small leak function. During this check, a 1st trip DTC might not be confirmed.

CAUTION:

- Never use compressed air, doing so may damage the EVAP system.
- Do not start engine.
- Do not exceeded 4.12 kPa (0.042 kg/cm², 0.6 psi).

1. Attach the EVAP service port adapter securely to the EVAP service port.

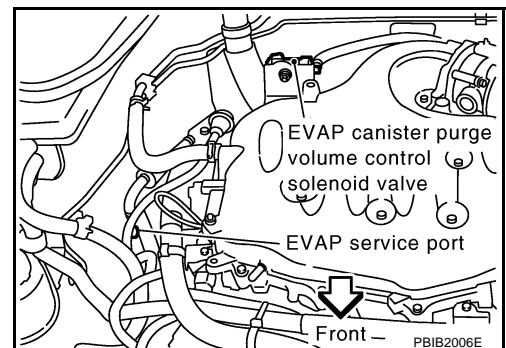

DTC P0456 EVAP CONTROL SYSTEM

[VQ35DE]

2. Set the pressure pump and a hose.
3. Also set a vacuum gauge via 3-way connector and a hose.
4. Turn ignition switch ON.
5. Connect GST and select MODE 8.
6. Using MODE 8 control the EVAP canister vent control valve (close).
7. Apply pressure and make sure the following conditions are satisfied.

Pressure to be applied: 2.7 kPa (20 mmHg, 0.79 inHg)

Time to be waited after the pressure drawn in to the EVAP system and the pressure to be dropped: 60 seconds and the pressure should not be dropped more than 0.4 kPa (3 mmHg, 0.12 inHg).

If NG, go to [EC-377, "Diagnostic Procedure"](#).

If OK, go to next step.

8. Disconnect GST.
9. Start engine and warm it up to normal operating temperature.
10. Turn ignition switch OFF and wait at least 10 seconds.
11. Restart engine and let it idle for 90 seconds.
12. Keep engine speed at 2,000 rpm for 30 seconds.
13. Turn ignition switch OFF.

NOTE:

For more information, refer to GST instruction manual.

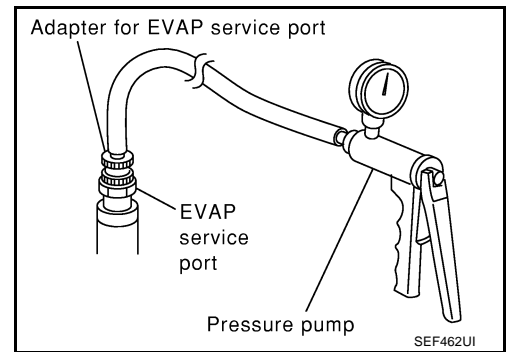

Diagnostic Procedure

1. CHECK FUEL FILLER CAP DESIGN

ABS006RS

1. Turn ignition switch OFF.
2. Check for genuine NISSAN fuel filler cap design.

OK or NG

OK >> GO TO 2.

NG >> Replace with genuine NISSAN fuel filler cap.

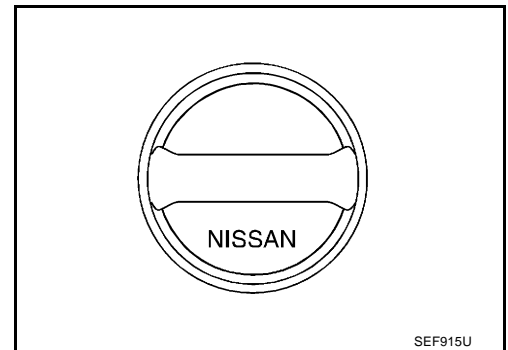

2. CHECK FUEL FILLER CAP INSTALLATION

Check that the cap is tightened properly by rotating the cap clockwise.

OK or NG

OK >> GO TO 3.

NG >> 1. Open fuel filler cap, then clean cap and fuel filler neck threads using air blower.

2. Retighten until ratcheting sound is heard.

3. CHECK FUEL FILLER CAP FUNCTION

Check for air releasing sound while opening the fuel filler cap.

OK or NG

OK >> GO TO 5.

NG >> GO TO 4.

4. CHECK FUEL TANK VACUUM RELIEF VALVE

Refer to [EC-646, "FUEL TANK VACUUM RELIEF VALVE \(BUILT INTO FUEL FULLER CAP\)"](#) .

OK or NG

OK >> GO TO 5.

NG >> Replace fuel filler cap with a genuine one.

5. INSTALL THE PRESSURE PUMP

To locate the EVAP leak, install EVAP service port adapter and pressure pump to EVAP service port securely. For the location of EVAP service port, refer to [EC-644, "EVAPORATIVE EMISSION LINE DRAWING"](#) .

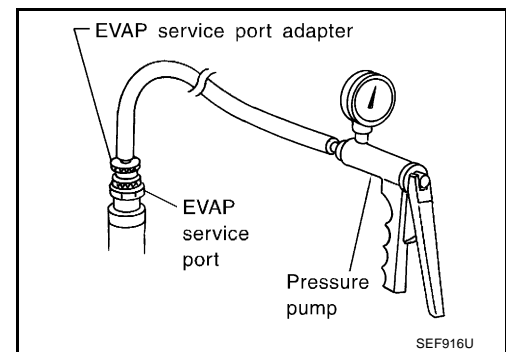
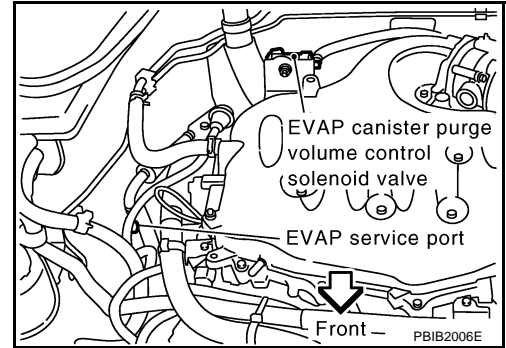

NOTE:

Improper installation of the EVAP service port adapter to the EVAP service port may cause leaking.

Models with CONSULT-II >> GO TO 6.

Models without CONSULT-II >> GO TO 7.

6. CHECK FOR EVAP LEAK

With CONSULT-II

1. Turn ignition switch ON.
2. Select "EVAP SYSTEM CLOSE" of "WORK SUPPORT" mode with CONSULT-II.
3. Touch "START" and apply pressure into the EVAP line until the pressure indicator reaches the middle of the bar graph.

NOTE:

- Never use compressed air or a high pressure pump.
- Do not exceed 4.12 kPa (0.042 kg/cm² , 0.6 psi) of pressure in the system.

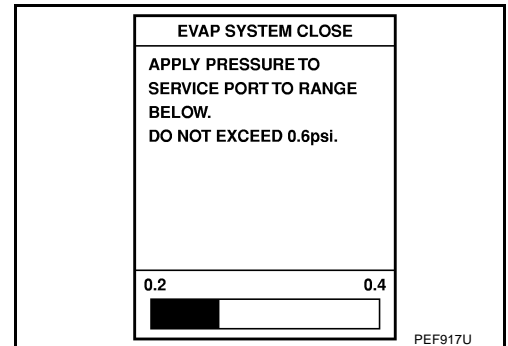

4. Using EVAP leak detector, locate the EVAP leak. For the leak detector, refer to the instruction manual for more details. Refer to [EC-644, "EVAPORATIVE EMISSION LINE DRAWING"](#)

OK or NG

- OK >> GO TO 8.
 NG >> Repair or replace.

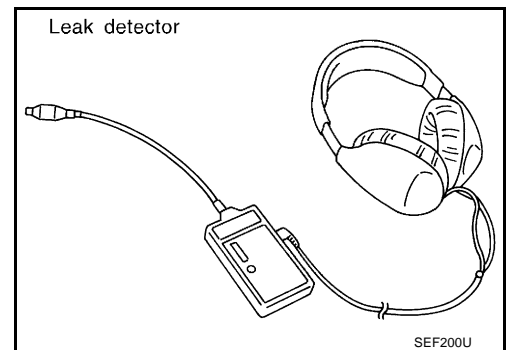

A
 EC
 C
 D
 E
 F
 G
 H
 I
 J
 K
 L
 M

7. CHECK FOR EVAP LEAK

⊗ **Without CONSULT-II**

1. Turn ignition switch OFF.
2. Apply 12 volts DC to EVAP canister vent control valve. The valve will close. (Continue to apply 12 volts until the end of test.)

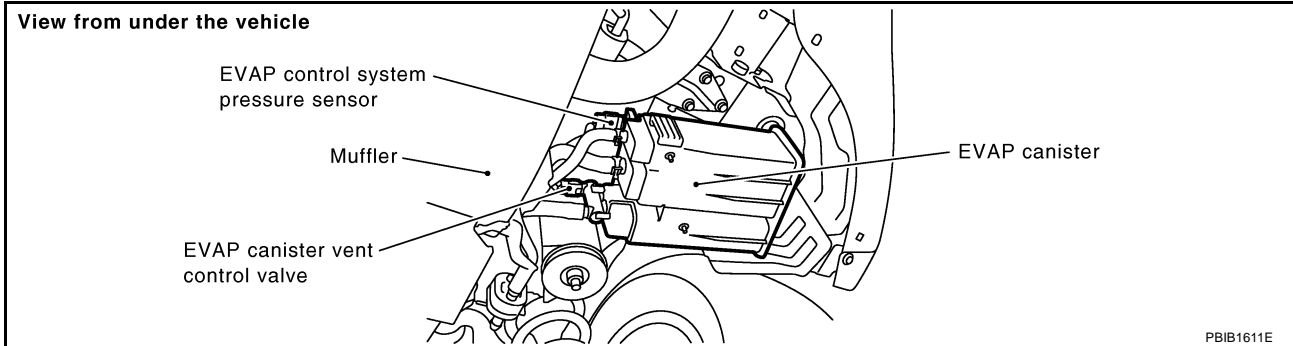

3. Pressurize the EVAP line using pressure pump with 1.3 to 2.7 kPa (10 to 20 mmHg, 0.39 to 0.79 inHg), then remove pump and EVAP service port adapter.

NOTE:

- Never use compressed air or a high pressure pump.
- Do not exceed 4.12 kPa (0.042 kg/cm², 0.6 psi) of pressure in the system.

4. Using EVAP leak detector, locate the EVAP leak. For the leak detector, refer to the instruction manual for more details. Refer to [EC-644, "EVAPORATIVE EMISSION LINE DRAWING"](#).

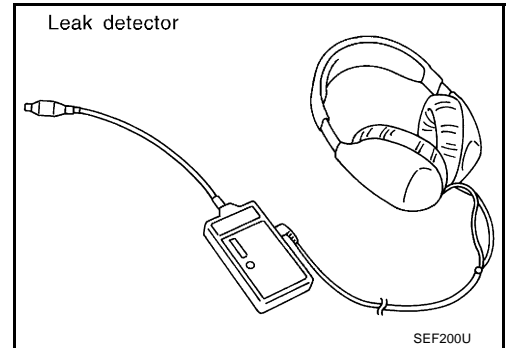

OK or NG

- OK >> GO TO 8.
 NG >> Repair or replace.

8. CHECK EVAP CANISTER VENT CONTROL VALVE

Check the following.

- EVAP canister vent control valve is installed properly.
 Refer to [EC-647, "Removal and Installation"](#).
- EVAP canister vent control valve.
 Refer to [EC-347, "Component Inspection"](#).

OK or NG

- OK >> GO TO 9.
 NG >> Repair or replace EVAP canister vent control valve and O-ring.

9. CHECK IF EVAP CANISTER SATURATED WITH WATER

1. Remove EVAP canister with EVAP canister vent control valve and EVAP control system pressure sensor attached.
2. Does water drain from the EVAP canister?

Yes or No

- Yes >> GO TO 10.
- No (With CONSULT-II)>>GO TO 12.
- No (Without CONSULT-II)>>GO TO 13.

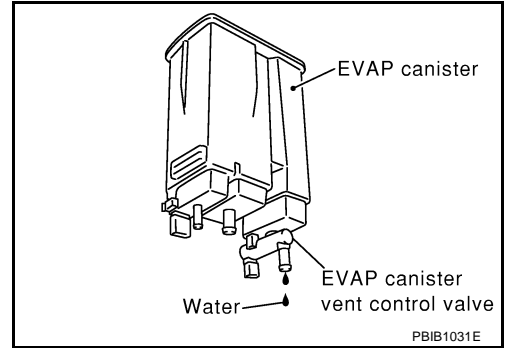

10. CHECK EVAP CANISTER

Weigh the EVAP canister with the EVAP canister vent control valve and EVAP control system pressure sensor attached.

The weight should be less than 2.1 kg (4.6 lb).

OK or NG

- OK (With CONSULT-II)>>GO TO 12.
- OK (Without CONSULT-II)>>GO TO 13.
- NG >> GO TO 11.

11. DETECT MALFUNCTIONING PART

Check the following.

- EVAP canister for damage
- EVAP hose between EVAP canister and vehicle frame for clogging or poor connection

>> Repair hose or replace EVAP canister.

12. CHECK EVAP CANISTER PURGE VOLUME CONTROL SOLENOID VALVE OPERATION

Ⓟ With CONSULT-II

1. Disconnect vacuum hose to EVAP canister purge volume control solenoid valve at EVAP service port.
2. Start engine.
3. Perform "PURG VOL CONT/V" in "ACTIVE TEST" mode.
4. Touch "Qu" on CONSULT-II screen to increase "PURG VOL CONT/V" opening to 100%.
5. Check vacuum hose for vacuum when revving engine up to 2,000 rpm.

OK or NG

- OK >> GO TO 15.
- NG >> GO TO 14.

ACTIVE TEST	
PURG VOL CONT/V	0 %
MONITOR	
ENG SPEED	XXX rpm
HO2S1 MNTR (B1)	LEAN
HO2S1 MNTR (B2)	LEAN
A/F ALPHA-B1	XXX %
A/F ALPHA-B2	XXX %

PBIB0147E

13. CHECK EVAP CANISTER PURGE VOLUME CONTROL SOLENOID VALVE OPERATION

⊗ Without CONSULT-II

1. Start engine and warm it up to normal operating temperature.
2. Stop engine.
3. Disconnect vacuum hose to EVAP canister purge volume control solenoid valve at EVAP service port.
4. Start engine and let it idle for at least 80 seconds.
5. Check vacuum hose for vacuum when revving engine up to 2,000 rpm.

Vacuum should exist.

OK or NG

- OK >> GO TO 16.
NG >> GO TO 14.

14. CHECK VACUUM HOSE

Check vacuum hoses for clogging or disconnection. Refer to [EC-30, "Vacuum Hose Drawing"](#) .

OK or NG

- OK >> GO TO 15.
NG >> Repair or reconnect the hose.

15. CHECK EVAP CANISTER PURGE VOLUME CONTROL SOLENOID VALVE

Refer to [EC-340, "Component Inspection"](#) .

OK or NG

- OK >> GO TO 16.
NG >> Replace EVAP canister purge volume control solenoid valve.

16. CHECK FUEL TANK TEMPERATURE SENSOR

Refer to [EC-277, "Component Inspection"](#) .

OK or NG

- OK >> GO TO 17.
NG >> Replace fuel level sensor unit.

17. CHECK EVAP CONTROL SYSTEM PRESSURE SENSOR

Refer to [EC-357, "Component Inspection"](#) .

OK or NG

- OK >> GO TO 18.
NG >> Replace EVAP control system pressure sensor.

18. CHECK EVAP PURGE LINE

Check EVAP purge line (pipe, rubber tube, fuel tank and EVAP canister) for cracks or improper connection. Refer to [EC-644, "EVAPORATIVE EMISSION LINE DRAWING"](#) .

OK or NG

- OK >> GO TO 19.
NG >> Repair or reconnect the hose.

19. CLEAN EVAP PURGE LINE

Clean EVAP purge line (pipe and rubber tube) using air blower.

>> GO TO 20.

20. CHECK EVAP/ORVR LINE

Check EVAP/ORVR line between EVAP canister and fuel tank for clogging, kink, looseness and improper connection. For location, refer to [EC-650, "ON BOARD REFUELING VAPOR RECOVERY \(ORVR\)"](#) .

OK or NG

- OK >> GO TO 21.
- NG >> Repair or replace hoses and tubes.

21. CHECK RECIRCULATION LINE

Check recirculation line between filler neck tube and fuel tank for clogging, kink, cracks, looseness and improper connection.

OK or NG

- OK >> GO TO 22.
- NG >> Repair or replace hose, tube or filler neck tube.

22. CHECK REFUELING EVAP VAPOR CUT VALVE

Refer to [EC-653, "Component Inspection"](#) .

OK or NG

- OK >> GO TO 23.
- NG >> Replace refueling EVAP vapor cut valve with fuel tank.

23. CHECK FUEL LEVEL SENSOR

Refer to [DI-25, "CHECK FUEL LEVEL SENSOR UNIT"](#) .

OK or NG

- OK >> GO TO 24.
- NG >> Replace fuel level sensor unit.

24. CHECK INTERMITTENT INCIDENT

Refer to [EC-135, "TROUBLE DIAGNOSIS FOR INTERMITTENT INCIDENT"](#) .

>> **INSPECTION END**

A

EC

C

D

E

F

G

H

I

J

K

L

M

DTC P0460 FUEL LEVEL SENSOR

PFP:25060

Component Description

ABS006RT

The fuel level sensor is mounted in the fuel level sensor unit. The sensor detects a fuel level in the fuel tank and transmits a signal to the “unified meter and A/C amp.”. The “unified meter and A/C amp.” sends the fuel level sensor signal to the ECM through CAN communication line.

It consists of two parts, one is mechanical float and the other is variable resistor. Fuel level sensor output voltage changes depending on the movement of the fuel mechanical float.

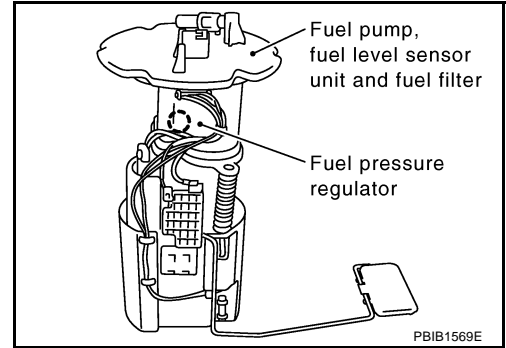

On Board Diagnosis Logic

ABS006RU

NOTE:

If DTC P0460 is displayed with DTC U1000 or U1001, first perform the trouble diagnosis for DTC U1000, U1001. Refer to [EC-142](#).

When the vehicle is parked, naturally the fuel level in the fuel tank is stable. It means that output signal of the fuel level sensor does not change. If ECM senses sloshing signal from the sensor, fuel level sensor malfunction is detected.

DTC No.	Trouble diagnosis name	DTC detecting condition	Possible cause
P0460 0460	Fuel level sensor circuit noise	Even though the vehicle is parked, a signal being varied is sent from the fuel level sensor to ECM.	<ul style="list-style-type: none"> ● Harness or connectors (The CAN communication line is open or shorted) ● Harness or connectors (The sensor circuit is open or shorted) ● Unified meter and A/C amp. ● Fuel level sensor

DTC Confirmation Procedure

ABS006RV

NOTE:

If DTC Confirmation Procedure has been previously conducted, always turn ignition switch OFF and wait at least 10 seconds before conducting the next test.

WITH CONSULT-II

1. Turn ignition switch ON.
2. Select “DATA MONITOR” mode with CONSULT-II.
3. Start engine and wait maximum of 2 consecutive minutes.
4. If 1st trip DTC is detected, go to [EC-385, "Diagnostic Procedure"](#)

DATA MONITOR	
MONITOR	NO DTC
FUEL T/TMP SE	XXX °C
FUEL LEVEL SE	XXX V

SEF195Y

WITH GST

Follow the procedure “WITH CONSULT-II” above.

Diagnostic Procedure

ABS006RW

1. CHECK DTC WITH "UNIFIED METER AND A/C AMP."

A

Refer to [DI-32, "SELF-DIAGNOSTIC RESULTS"](#) .

OK or NG

EC

OK >> GO TO 2.

NG >> Go to [DI-20, "Fuel Level Sensor Signal Inspection 1"](#) .

2. CHECK INTERMITTENT INCIDENT

C

Refer to [EC-135, "TROUBLE DIAGNOSIS FOR INTERMITTENT INCIDENT"](#) .

D

>> INSPECTION END

Removal and Installation FUEL LEVEL SENSOR

ABS006RX

E

Refer to [FL-4, "FUEL LEVEL SENSOR UNIT, FUEL FILTER AND FUEL PUMP ASSEMBLY"](#) .

F

G

H

I

J

K

L

M

DTC P0461 FUEL LEVEL SENSOR

PFP:25060

Component Description

ABS006RY

The fuel level sensor is mounted in the fuel level sensor unit. The sensor detects a fuel level in the fuel tank and transmits a signal to the “unified meter and A/C amp.”. The “unified meter and A/C amp.” sends the fuel level sensor signal to the ECM through CAN communication line.

It consists of two parts, one is mechanical float and the other is variable resistor. Fuel level sensor output voltage changes depending on the movement of the fuel mechanical float.

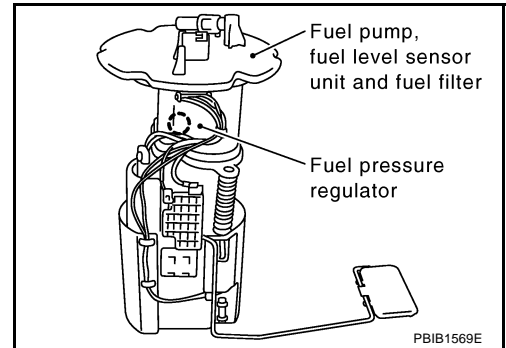

On Board Diagnosis Logic

ABS006RZ

NOTE:

If DTC P0461 is displayed with DTC U1000 or U1001, first perform the trouble diagnosis for DTC U1000, U1001. Refer to [EC-142](#).

Driving long distances naturally affect fuel gauge level.

This diagnosis detects the fuel gauge malfunction of the gauge not moving even after a long distance has been driven.

DTC No.	Trouble diagnosis name	DTC detecting condition	Possible cause
P0461 0461	Fuel level sensor circuit range/performance	The output signal of the fuel level sensor does not change within the specified range even though the vehicle has been driven a long distance.	<ul style="list-style-type: none"> ● Harness or connectors (The CAN communication line is open or shorted) ● Harness or connectors (The sensor circuit is open or shorted) ● Unified meter and A/C amp. ● Fuel level sensor

Overall Function Check

ABS006S0

Use this procedure to check the overall function of the fuel level sensor function. During this check, a 1st trip DTC might not be confirmed.

WARNING:

When performing following procedure, be sure to observe the handling of the fuel. Refer to [FL-10, "FUEL TANK"](#).

TESTING CONDITION:

Before starting overall function check, preparation of draining fuel and refilling fuel is required.

📱 **WITH CONSULT-II**

NOTE:

Start from step 10, if it is possible to confirm that the fuel cannot be drained by 30 ℓ (7-7/8 US gal, 6-5/8 Imp gal) in advance.

1. Prepare a fuel container and a spare hose.
2. Release fuel pressure from fuel line, refer to [EC-51, "FUEL PRESSURE RELEASE"](#).
3. Remove the fuel feed hose on the fuel level sensor unit.
4. Connect a spare fuel hose where the fuel feed hose was removed.
5. Turn ignition switch OFF and wait at least 10 seconds then turn ON.
6. Select “FUEL LEVEL SE” in “DATA MONITOR” mode with CONSULT-II.

DTC P0461 FUEL LEVEL SENSOR

[VQ35DE]

7. Check "FUEL LEVEL SE" output voltage and note it.
8. Select "FUEL PUMP" in "ACTIVE TEST" mode with CONSULT-II.
9. Touch ON and drain fuel approximately 30 ℓ (7-7/8 US gal, 6-5/8 Imp gal) and stop it.
10. Check "FUEL LEVEL SE" output voltage and note it.
11. Fill fuel into the fuel tank for 30 ℓ (7-7/8 US gal, 6-5/8 Imp gal).
12. Check "FUEL LEVEL SE" output voltage and note it.
13. Confirm whether the voltage changes more than 0.03V during step 7 to 10 and 10 to 12.
If NG, go to [EC-387, "Diagnostic Procedure"](#) .

DATA MONITOR	
MONITOR	NO DTC
FUEL T/TMP SE	XXX °C
FUEL LEVEL SE	XXX V

SEP195Y

WITH GST

NOTE:

Start from step 8, if it is possible to confirm that the fuel cannot be drained by 30 ℓ (7-7/8 US gal, 6-5/8 Imp gal) in advance.

1. Prepare a fuel container and a spare hose.
2. Release fuel pressure from fuel line. Refer to [EC-51, "FUEL PRESSURE RELEASE"](#) .
3. Remove the fuel feed hose on the fuel level sensor unit.
4. Connect a spare fuel hose where the fuel feed hose was removed.
5. Turn ignition switch ON.
6. Drain fuel by 30 ℓ (7-7/8 US gal, 6-5/8 Imp gal) from the fuel tank using proper equipment.
7. Confirm that the fuel gauge indication varies.
8. Fill fuel into the fuel tank for 30 ℓ (7-7/8 US gal, 6-5/8 Imp gal).
9. Confirm that the fuel gauge indication varies.
10. If NG, go to [EC-387, "Diagnostic Procedure"](#) .

Diagnostic Procedure

ABS006S1

1. CHECK DTC WITH "UNIFIED METER AND A/C AMP."

Refer to [DI-32, "SELF-DIAGNOSTIC RESULTS"](#) .

OK or NG

- OK >> GO TO 2.
- NG >> Go to [DI-20, "Fuel Level Sensor Signal Inspection 1"](#) .

2. CHECK INTERMITTENT INCIDENT

Refer to [EC-135, "TROUBLE DIAGNOSIS FOR INTERMITTENT INCIDENT"](#) .

>> INSPECTION END

Removal and Installation FUEL LEVEL SENSOR

ABS006S2

Refer to [FL-4, "FUEL LEVEL SENSOR UNIT, FUEL FILTER AND FUEL PUMP ASSEMBLY"](#) .

DTC P0462, P0463 FUEL LEVEL SENSOR

PFP:25060

Component Description

ABS006S3

The fuel level sensor is mounted in the fuel level sensor unit. The sensor detects a fuel level in the fuel tank and transmits a signal to the “unified meter and A/C amp.” The “unified meter and A/C amp.” sends the fuel level sensor signal to the ECM through CAN communication line.

It consists of two parts, one is mechanical float and the other is variable resistor. Fuel level sensor output voltage changes depending on the movement of the fuel mechanical float.

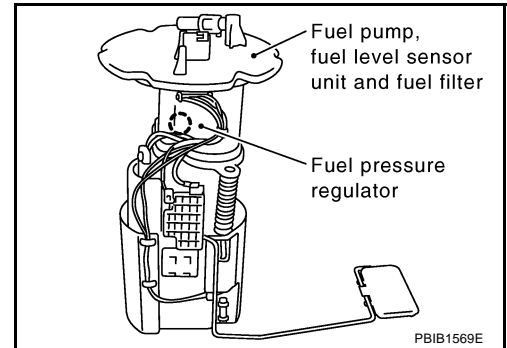

On Board Diagnosis Logic

ABS006S4

NOTE:

If DTC P0462 or P0463 is displayed with DTC U1000 or U1001, first perform the trouble diagnosis for DTC U1000, U1001. Refer to [EC-142](#).

This diagnosis indicates the former, to detect open or short circuit malfunction.

DTC No.	Trouble diagnosis name	DTC detecting condition	Possible cause
P0462 0462	Fuel level sensor circuit low input	An excessively low voltage from the sensor is sent to ECM.	<ul style="list-style-type: none"> ● Harness or connectors (The CAN communication line is open or shorted) ● Harness or connectors (The sensor circuit is open or shorted) ● Unified meter and A/C amp. ● Fuel level sensor
P0463 0463	Fuel level sensor circuit high input	An excessively high voltage from the sensor is sent to ECM.	

DTC Confirmation Procedure

ABS006S5

NOTE:

If DTC Confirmation Procedure has been previously conducted, always turn ignition switch OFF and wait at least 10 seconds before conducting the next test.

TESTING CONDITION:

Before performing the following procedure, confirm that battery voltage is more than 11V at ignition switch ON.

WITH CONSULT-II

1. Turn ignition switch ON.
2. Select “DATA MONITOR” mode with CONSULT-II.
3. Wait at least 5 seconds.
4. If 1st trip DTC is detected, go to [EC-389, "Diagnostic Procedure"](#)

DATA MONITOR	
MONITOR	NO DTC
FUEL T/TMP SE	XXX °C
FUEL LEVEL SE	XXX V

SEF195Y

WITH GST

Follow the procedure “WITH CONSULT-II” above.

Diagnostic Procedure

ABS006S7

1. CHECK DTC WITH "UNIFIED METER AND A/C AMP."

Refer to [DI-32, "SELF-DIAGNOSTIC RESULTS"](#) .

OK or NG

OK >> GO TO 2.

NG >> Go to [DI-20, "Fuel Level Sensor Signal Inspection 1"](#) .

2. CHECK INTERMITTENT INCIDENT

Refer to [EC-135, "TROUBLE DIAGNOSIS FOR INTERMITTENT INCIDENT"](#) .

>> INSPECTION END

Removal and Installation FUEL LEVEL SENSOR

ABS006S8

Refer to [FL-4, "FUEL LEVEL SENSOR UNIT, FUEL FILTER AND FUEL PUMP ASSEMBLY"](#) .

A

EC

C

D

E

F

G

H

I

J

K

L

M

DTC P0500 VSS

PF:32702

Description

ABS006S9

NOTE:

If DTC P0500 is displayed with DTC U1000 or U1001, first perform the trouble diagnosis for DTC U1000, U1001. Refer to [EC-142](#).

The vehicle speed signal is sent to the “unified meter and A/C amp.” from the “ABS actuator and electric unit (control unit)” by CAN communication line. The “unified meter and A/C amp.” then sends a signal to the ECM by CAN communication line.

On Board Diagnosis Logic

ABS006SA

DTC No.	Trouble diagnosis name	DTC detecting condition	Possible cause
P0500 0500	Vehicle speed sensor	The almost 0 km/h (0 MPH) signal from vehicle speed sensor is sent to ECM even when vehicle is being driven.	<ul style="list-style-type: none"> ● Harness or connectors (The CAN communication line is open or shorted) ● Harness or connectors (The vehicle speed signal circuit is open or shorted) ● Wheel sensor ● Unified meter and A/C amp. ● ABS actuator and electric unit (control unit)

DTC Confirmation Procedure

ABS006SB

CAUTION:

Always drive vehicle at a safe speed.

NOTE:

If DTC Confirmation Procedure has been previously conducted, always turn ignition switch OFF and wait at least 10 seconds before conducting the next test.

TESTING CONDITION:

Steps 1 and 2 may be conducted with the drive wheels lifted in the shop or by driving the vehicle. If a road test is expected to be easier, it is unnecessary to lift the vehicle.

WITH CONSULT-II

1. Start engine (TCS switch or VDC switch OFF).
2. Read “VHCL SPEED SE” in “DATA MONITOR” mode with CONSULT-II. The vehicle speed on CONSULT-II should exceed 10 km/h (6 MPH) when rotating wheels with suitable gear position.
If NG, go to [EC-391, "Diagnostic Procedure"](#).
If OK, go to following step.
3. Select “DATA MONITOR” mode with CONSULT-II.
4. Warm engine up to normal operating temperature.
5. Maintain the following conditions for at least 60 consecutive seconds.

ENG SPEED	1,700 - 6,000 rpm
COOLAN TEMP/S	More than 70°C (158°F)
B/FUEL SCHDL	4.9 - 31.8 msec
Selector lever	Except P or N position
PW/ST SIGNAL	OFF

6. If 1st trip DTC is detected, go to [EC-391, "Diagnostic Procedure"](#)

DATA MONITOR	
MONITOR	NO DTC
ENG SPEED	XXX rpm
COOLAN TEMP/S	XXX °C
B/FUEL SCHDL	XXX msec
PW/ST SIGNAL	OFF
VHCL SPEED SE	XXX km/h

SEF196Y

Overall Function Check

ABS006SC

Use this procedure to check the overall function of the vehicle speed sensor circuit. During this check, a 1st trip DTC might not be confirmed.

WITH GST

1. Lift up drive wheels.
2. Start engine.
3. Read vehicle speed sensor signal in MODE 1 with GST.
The vehicle speed sensor on GST should be able to exceed 10 km/h (6 MPH) when rotating wheels with suitable gear position.
4. If NG, go to [EC-391, "Diagnostic Procedure"](#) .

Diagnostic Procedure

ABS006SD

1. CHECK DTC WITH "ABS ACTUATOR AND ELECTRIC UNIT (CONTROL UNIT)"Refer to [BRC-12, "TROUBLE DIAGNOSIS"](#) .**OK or NG**

- OK >> GO TO 2.
NG >> Repair or replace.

2. CHECK DTC WITH "UNIFIED METER AND A/C AMP."Refer to [DI-4, "COMBINATION METERS"](#) .

>> INSPECTION END

A

EC

C

D

E

F

G

H

I

J

K

L

M

DTC P0506 ISC SYSTEM

PFP:23781

Description

ABS006SE

NOTE:

If DTC P0506 is displayed with other DTC, first perform the trouble diagnosis for the other DTC.

The ECM controls the engine idle speed to a specified level through the fine adjustment of the air, which is let into the intake manifold, by operating the electric throttle control actuator. The operating of the throttle valve is varied to allow for optimum control of the engine idling speed. The crankshaft position sensor (POS) detects the actual engine speed and sends a signal to the ECM.

The ECM controls the electric throttle control actuator so that the engine speed coincides with the target value memorized in the ECM. The target engine speed is the lowest speed at which the engine can operate steadily. The optimum value stored in the ECM is determined by taking into consideration various engine conditions, such as during warming up, deceleration, and engine load (air conditioner, power steering and cooling fan operation, etc.).

On Board Diagnosis Logic

ABS006SF

DTC No.	Trouble diagnosis name	DTC detecting condition	Possible cause
P0506 0506	Idle speed control system RPM lower than expected	The idle speed is less than the target idle speed by 100 rpm or more.	<ul style="list-style-type: none"> ● Electric throttle control actuator ● Intake air leak

DTC Confirmation Procedure

ABS006SG

NOTE:

- If DTC Confirmation Procedure has been previously conducted, always turn ignition switch OFF and wait at least 10 seconds before conducting the next test.
- **If the target idle speed is out of the specified value, perform, [EC-49, "Idle Air Volume Learning"](#) , before conducting DTC Confirmation Procedure. For the target idle speed, refer to the [EC-660, "SERVICE DATA AND SPECIFICATIONS \(SDS\)"](#) .**

TESTING CONDITION:

- Before performing the following procedure, confirm that battery voltage is more than 11V at idle.
- Always perform the test at a temperature above -10°C (14°F).

WITH CONSULT-II

1. Open engine hood.
2. Start engine and warm it up to normal operating temperature.
3. Turn ignition switch OFF and wait at least 10 seconds.
4. Turn ignition switch ON again and select "DATA MONITOR" mode with CONSULT-II.
5. Start engine and run it for at least 1 minute at idle speed.
6. If 1st trip DTC is detected, go to [EC-393, "Diagnostic Procedure"](#)

DATA MONITOR	
MONITOR	NO DTC
ENG SPEED	XXX rpm
COOLAN TEMP/S	XXX °C

SEF174Y

WITH GST

Follow the procedure "WITH CONSULT-II" above.

Diagnostic Procedure**1. CHECK INTAKE AIR LEAK**

1. Start engine and let it idle.
2. Listen for an intake air leak after the mass air flow sensor.

OK or NG

- OK >> GO TO 2.
NG >> Discover air leak location and repair.

2. REPLACE ECM

1. Stop engine.
2. Replace ECM.
3. Perform initialization of IVIS(NATS) system and registration of all IVIS(NATS) ignition key IDs. Refer to [BL-208, "ECM Re-communicating Function"](#).
4. Perform [EC-49, "Accelerator Pedal Released Position Learning"](#).
5. Perform [EC-49, "Throttle Valve Closed Position Learning"](#).
6. Perform [EC-49, "Idle Air Volume Learning"](#).

>> INSPECTION END

A

EC

C

D

E

F

G

H

I

J

K

L

M

DTC P0507 ISC SYSTEM

PFP:23781

Description

ABS006SI

NOTE:

If DTC P0507 is displayed with other DTC, first perform the trouble diagnosis for the other DTC.

The ECM controls the engine idle speed to a specified level through the fine adjustment of the air, which is let into the intake manifold, by operating the electric throttle control actuator. The operating of the throttle valve is varied to allow for optimum control of the engine idling speed. The crankshaft position sensor (POS) detects the actual engine speed and sends a signal to the ECM.

The ECM controls the electric throttle control actuator so that the engine speed coincides with the target value memorized in the ECM. The target engine speed is the lowest speed at which the engine can operate steadily. The optimum value stored in the ECM is determined by taking into consideration various engine conditions, such as during warming up, deceleration, and engine load (air conditioner, power steering and cooling fan operation, etc.).

On Board Diagnosis Logic

ABS006SJ

DTC No.	Trouble diagnosis name	DTC detecting condition	Possible cause
P0507 0507	Idle speed control system RPM higher than expected	The idle speed is more than the target idle speed by 200 rpm or more.	<ul style="list-style-type: none"> ● Electric throttle control actuator ● Intake air leak ● PCV system

DTC Confirmation Procedure

ABS006SK

NOTE:

- If DTC Confirmation Procedure has been previously conducted, always turn ignition switch OFF and wait at least 10 seconds before conducting the next test.
- **If the target idle speed is out of the specified value, perform, [EC-49. "Idle Air Volume Learning"](#) , before conducting DTC Confirmation Procedure. For the target idle speed, refer to the [EC-660. "SERVICE DATA AND SPECIFICATIONS \(SDS\)"](#) .**

TESTING CONDITION:

- Before performing the following procedure, confirm that battery voltage is more than 11V at idle.
- Always perform the test at a temperature above -10°C (14°F).

WITH CONSULT-II

1. Open engine hood.
2. Start engine and warm it up to normal operating temperature.
3. Turn ignition switch OFF and wait at least 10 seconds.
4. Turn ignition switch ON again and select "DATA MONITOR" mode with CONSULT-II.
5. Start engine and run it for at least 1 minute at idle speed.
6. If 1st trip DTC is detected, go to [EC-395. "Diagnostic Procedure"](#)

DATA MONITOR	
MONITOR	NO DTC
ENG SPEED	XXX rpm
COOLAN TEMP/S	XXX °C

SEF174Y

WITH GST

Follow the procedure "WITH CONSULT-II" above.

Diagnostic Procedure**1. CHECK PCV HOSE CONNECTION**

Confirm that PCV hose is connected correctly.

OK or NG

OK >> GO TO 2.

NG >> Repair or replace.

2. CHECK INTAKE AIR LEAK

1. Start engine and let it idle.
2. Listen for an intake air leak after the mass air flow sensor.

OK or NG

OK >> GO TO 3.

NG >> Discover air leak location and repair.

3. REPLACE ECM

1. Stop engine.
2. Replace ECM.
3. Perform initialization of IVIS(NATS) system and registration of all IVIS(NATS) ignition key IDs. Refer to [BL-208, "ECM Re-communicating Function"](#).
4. Perform [EC-49, "Accelerator Pedal Released Position Learning"](#).
5. Perform [EC-49, "Throttle Valve Closed Position Learning"](#).
6. Perform [EC-49, "Idle Air Volume Learning"](#).

>> **INSPECTION END**

A

EC

C

D

E

F

G

H

I

J

K

L

M

DTC P0550 PSP SENSOR

PFP:49763

Component Description

ABS006SM

Power steering pressure (PSP) sensor is installed to the power steering high-pressure tube and detects a power steering load. This sensor is a potentiometer which transforms the power steering load into output voltage, and emits the voltage signal to the ECM. The ECM controls the electric throttle control actuator and adjusts the throttle valve opening angle to increase the engine speed and adjusts the idle speed for the increased load.

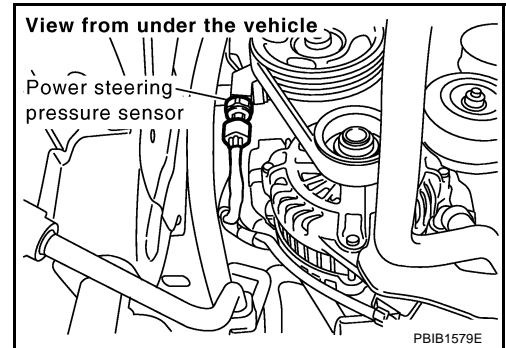

CONSULT-II Reference Value in Data Monitor Mode

ABS006SN

Specification data are reference values.

MONITOR ITEM	CONDITION		SPECIFICATION
PW/ST SIGNAL	<ul style="list-style-type: none"> Engine: After warming up, idle the engine 	Steering wheel is in neutral position. (Forward direction)	OFF
		Steering wheel is turned.	ON

On Board Diagnosis Logic

ABS006SO

The MIL will not light up for this diagnosis.

NOTE:

If DTC P0550 is displayed with DTC P1229, first perform the trouble diagnosis for DTC P1229. Refer to [EC-489, "DTC P1229 SENSOR POWER SUPPLY"](#).

DTC No.	Trouble diagnosis name	DTC detecting condition	Possible cause
P0550 0550	Power steering pressure sensor circuit	An excessively low or high voltage from the sensor is sent to ECM.	<ul style="list-style-type: none"> Harness or connectors (The sensor circuit is open or shorted) Power steering pressure sensor

DTC Confirmation Procedure

ABS006SP

NOTE:

If DTC Confirmation Procedure has been previously conducted, always turn ignition switch OFF and wait at least 10 seconds before conducting the next test.

Ⓜ **WITH CONSULT-II**

- Turn ignition switch ON.
- Select "DATA MONITOR" mode with CONSULT-II.
- Start engine and let it idle for at least 5 seconds.
- If 1st trip DTC is detected, go to [EC-398, "Diagnostic Procedure"](#).

DATA MONITOR	
MONITOR	NO DTC
ENG SPEED	XXX rpm

SEF058Y

Ⓜ **WITH GST**

Follow the procedure "WITH CONSULT-II" above.



DTC P0550 PSP SENSOR

[VQ35DE]

Wiring Diagram

ABS006SQ

EC-PS/SEN-01

 : DETECTABLE LINE FOR DTC
 : NON-DETECTABLE LINE FOR DTC

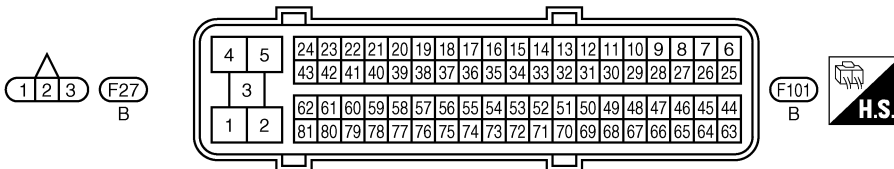
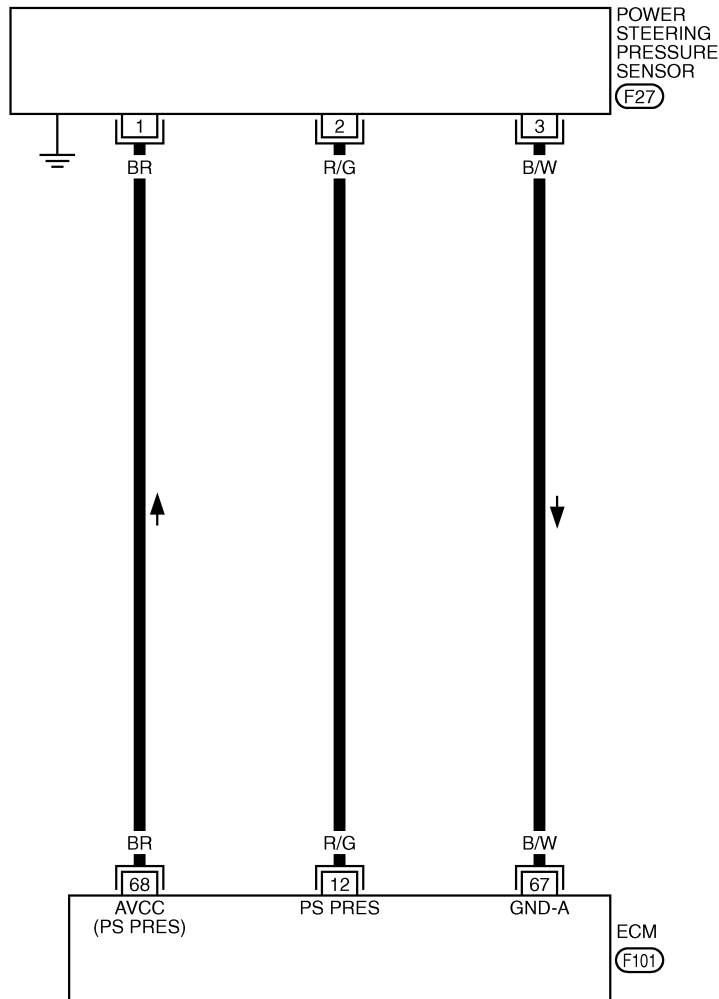

TBWM0302E

DTC P0550 PSP SENSOR

[VQ35DE]

Specification data are reference values and are measured between each terminal and ground.

CAUTION:

Do not use ECM ground terminals when measuring input/output voltage. Doing so may result in damage to the ECM's transistor. Use a ground other than ECM terminals, such as the ground.

TER-MINAL NO.	WIRE COLOR	ITEM	CONDITION	DATA (DC Voltage)
12	R/G	Power steering pressure sensor	[Engine is running] ● Steering wheel is being turned.	0.5 - 4.5V
			[Engine is running] ● Steering wheel is not being turned.	0.4 - 0.8V
67	B/W	Sensor ground (Power steering pressure sensor)	[Engine is running] ● Warm-up condition ● Idle speed	Approximately 0V
68	BR	Sensor power supply (Power steering pressure sensor)	[Ignition switch: ON]	Approximately 5V

Diagnostic Procedure

ABS00CHL

1. CHECK GROUND CONNECTIONS

1. Turn ignition switch OFF.
2. Loosen and retighten ground three screws on the body. Refer to [EC-141, "Ground Inspection"](#) .

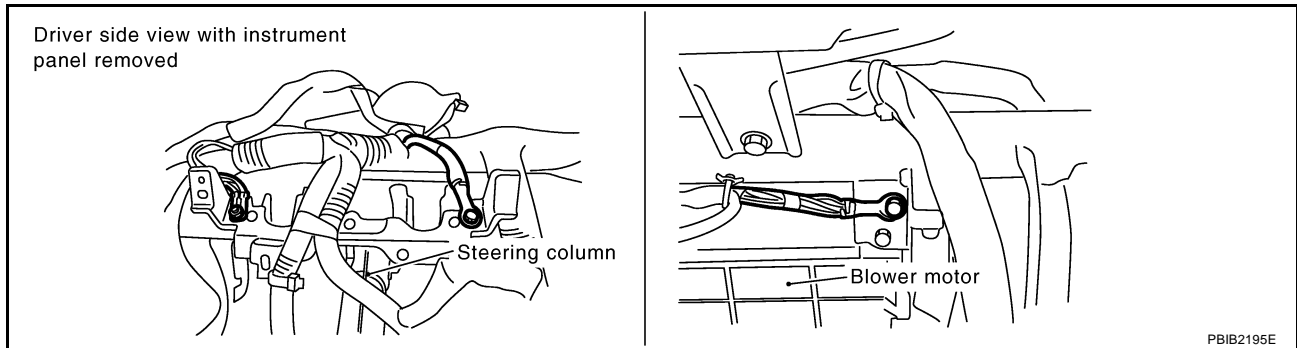

OK or NG

- OK >> GO TO 2.
- NG >> Repair or replace ground connections.

2. CHECK PSP SENSOR POWER SUPPLY CIRCUIT

1. Disconnect PSP sensor harness connector.
2. Turn ignition switch ON.

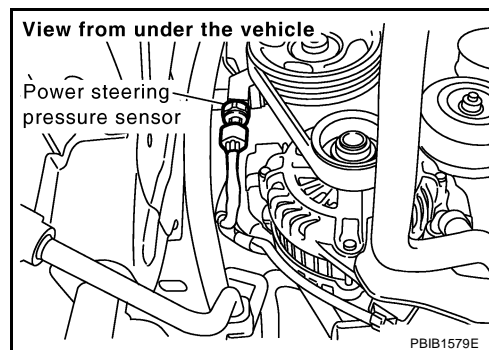

3. Check voltage between PSP sensor terminal 1 and ground with CONSULT-II or tester.

Voltage: Approximately 5V

OK or NG

OK >> GO TO 3.

NG >> Repair open circuit or short to ground or short to power in harness or connectors.

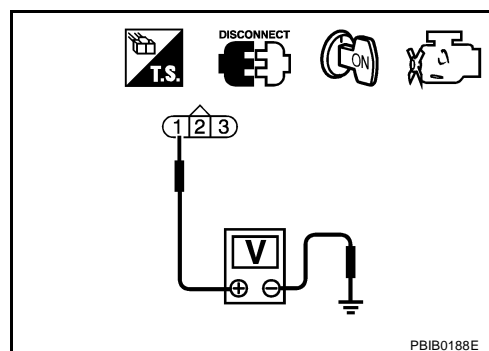

3. CHECK PSP SENSOR GROUND CIRCUIT FOR OPEN AND SHORT

1. Turn ignition switch OFF.
2. Disconnect ECM harness connector.
3. Check harness continuity between PSP sensor terminal 3 and ECM terminal 67. Refer to Wiring Diagram.

Continuity should exist.

4. Also check harness for short to ground and to power.

OK or NG

OK >> GO TO 4.

NG >> Repair open circuit or short to ground or short to power in harness or connectors.

4. CHECK PSP SENSOR INPUT SIGNAL CIRCUIT FOR OPEN AND SHORT

1. Check harness continuity between ECM terminal 12 and PSP sensor terminal 2.

Continuity should exist.

2. Also check harness for short to ground and short to power.

OK or NG

OK >> GO TO 5.

NG >> Repair open circuit or short to ground or short to power in harness or connectors.

5. CHECK PSP SENSOR

Refer to [EC-400, "Component Inspection"](#).

OK or NG

OK >> GO TO 6.

NG >> Replace PSP sensor.

6. CHECK INTERMITTENT INCIDENT

Refer to [EC-135, "TROUBLE DIAGNOSIS FOR INTERMITTENT INCIDENT"](#) .

>> INSPECTION END

**Component Inspection
POWER STEERING PRESSURE SENSOR**

ABS006SS

1. Reconnect all harness connectors disconnected.
2. Start engine and let it idle.
3. Check voltage between ECM terminal 12 and ground under the following conditions.

Condition	Voltage
Steering wheel is being turned.	0.5 - 4.5V
Steering wheel is not being turned.	0.4 - 0.8V

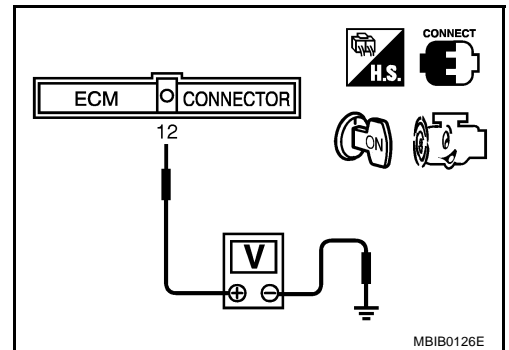

MBIB0126E

**Removal and Installation
POWER STEERING PRESSURE SENSOR**

ABS00A3Z

Refer to [PS-41, "HYDRAULIC LINE"](#) .

DTC P0605 ECM

PF2:23710

Component Description

ABS006ST

The ECM consists of a microcomputer and connectors for signal input and output and for power supply. The ECM controls the engine.

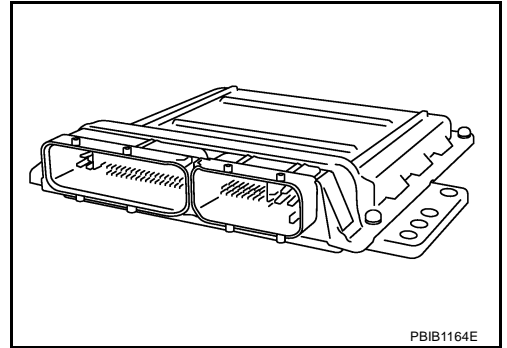

ABS006SU

On Board Diagnosis Logic

This self-diagnosis has one or two trip detection logic.

DTC No.	Trouble diagnosis name	DTC detecting condition		Possible cause
P0605 0605	Engine control module	A)	ECM calculation function is malfunctioning.	● ECM
		B)	ECM EEPROM system is malfunctioning.	
		C)	ECM self shut-off function is malfunctioning.	

FAIL-SAFE MODE

ECM enters fail-safe mode when the malfunction A is detected.

Detected items	Engine operation condition in fail-safe mode
Malfunction A	<ul style="list-style-type: none"> ● ECM stops the electric throttle control actuator control, throttle valve is maintained at a fixed opening (approx. 5 degrees) by the return spring. ● ECM deactivates ICC operation. ● ECM deactivates ASCD operation.

DTC Confirmation Procedure

ABS006SV

Perform "PROCEDURE FOR MALFUNCTION A" first. If the 1st trip DTC cannot be confirmed, perform PROCEDURE FOR MALFUNCTION B. If there is no malfunction on PROCEDURE FOR MALFUNCTION B, perform PROCEDURE FOR MALFUNCTION C.

NOTE:

If DTC Confirmation Procedure has been previously conducted, always turn ignition switch OFF and wait at least 10 seconds before conducting the next test.

PROCEDURE FOR MALFUNCTION A

With CONSULT-II

1. Turn ignition switch ON.
2. Select "DATA MONITOR" mode with CONSULT-II.
3. If 1st trip DTC is detected, go to [EC-402, "Diagnostic Procedure"](#)

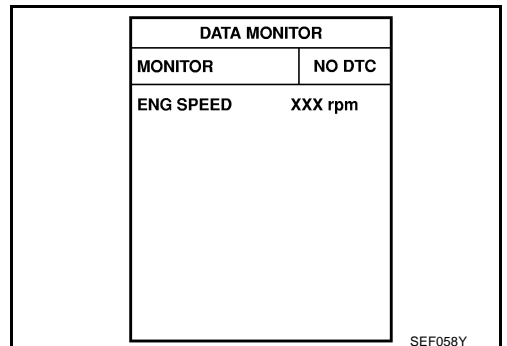

With GST

Follow the procedure "With CONSULT-II" above.

PROCEDURE FOR MALFUNCTION B

With CONSULT-II

1. Turn ignition switch ON and wait at least 1 second.
2. Select "DATA MONITOR" mode with CONSULT-II.
3. Turn ignition switch OFF, wait at least 10 seconds, and then turn ON.
4. If 1st trip DTC is detected, go to [EC-402. "Diagnostic Procedure"](#)

DATA MONITOR	
MONITOR	NO DTC
ENG SPEED	XXX rpm

SEF058Y

With GST

Follow the procedure "With CONSULT-II" above.

PROCEDURE FOR MALFUNCTION C

With CONSULT-II

1. Turn ignition switch ON and wait at least 1 second.
2. Select "DATA MONITOR" mode with CONSULT-II.
3. Turn ignition switch OFF, wait at least 10 seconds, and then turn ON.
4. Repeat step 3 for 32 times.
5. If 1st trip DTC is detected, go to [EC-402. "Diagnostic Procedure"](#)

DATA MONITOR	
MONITOR	NO DTC
ENG SPEED	XXX rpm

SEF058Y

With GST

Follow the procedure "With CONSULT-II" above.

Diagnostic Procedure

ABS006SW

1. INSPECTION START

With CONSULT-II

1. Turn ignition switch ON.
2. Select "SELF DIAG RESULTS" mode with CONSULT-II.
3. Touch "ERASE".
4. **Perform DTC Confirmation Procedure.**
See [EC-401](#) .
5. Is the 1st trip DTC P0605 displayed again?

With GST

1. Turn ignition switch ON.
2. Select MODE 4 with GST.
3. Touch "ERASE".
4. **Perform DTC Confirmation Procedure.**
See [EC-401](#) .
5. Is the 1st trip DTC P0605 displayed again?

Yes or No

Yes >> GO TO 2.

No >> **INSPECTION END**

2. REPLACE ECM

1. Replace ECM.
2. Perform initialization of IVIS(NATS) system and registration of all IVIS(NATS) ignition key IDs. Refer to [BL-208, "ECM Re-communicating Function"](#) .
3. Perform [EC-49, "Accelerator Pedal Released Position Learning"](#) .
4. Perform [EC-49, "Throttle Valve Closed Position Learning"](#) .
5. Perform [EC-49, "Idle Air Volume Learning"](#) .

>> INSPECTION END

A

EC

C

D

E

F

G

H

I

J

K

L

M

DTC P1065 ECM POWER SUPPLY

PFP:23710

Component Description

ABS006SX

Battery voltage is supplied to the ECM even when the ignition switch is turned OFF for the ECM memory function of the DTC memory, the air-fuel ratio feedback compensation value memory, the idle air volume learning value memory, etc.

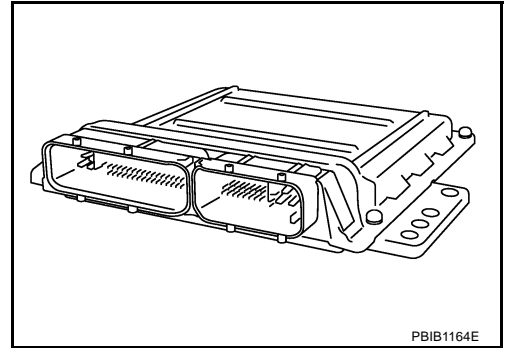

On Board Diagnosis Logic

ABS006SY

DTC No.	Trouble diagnosis name	DTC detecting condition	Possible cause
P1065 1065	ECM power supply circuit	ECM back-up RAM system does not function properly.	<ul style="list-style-type: none"> ● Harness or connectors [ECM power supply (back-up) circuit is open or shorted.] ● ECM

DTC Confirmation Procedure

ABS006SZ

NOTE:

If DTC Confirmation Procedure has been previously conducted, always turn ignition switch OFF and wait at least 10 seconds before conducting the next test.

WITH CONSULT-II

1. Turn ignition switch ON and wait at least 1 second.
2. Select "DATA MONITOR" mode with CONSULT-II.
3. Start engine and let it idle for 1 second.
4. Turn ignition switch OFF, wait at least 10 seconds, and then turn ON.
5. Repeat steps 3 and 4 for 4 times.
6. If 1st trip DTC is detected, go to [EC-406. "Diagnostic Procedure"](#)

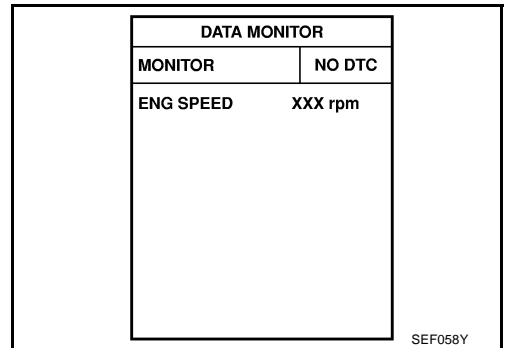

WITH GST

Follow the procedure "WITH CONSULT-II" above.

DTC P1065 ECM POWER SUPPLY

[VQ35DE]

Wiring Diagram

ABS006T0

EC-ECM/PW-01

: DETECTABLE LINE FOR DTC
 : NON-DETECTABLE LINE FOR DTC

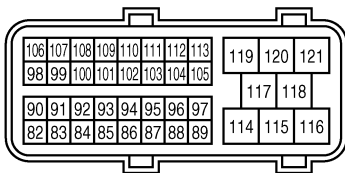
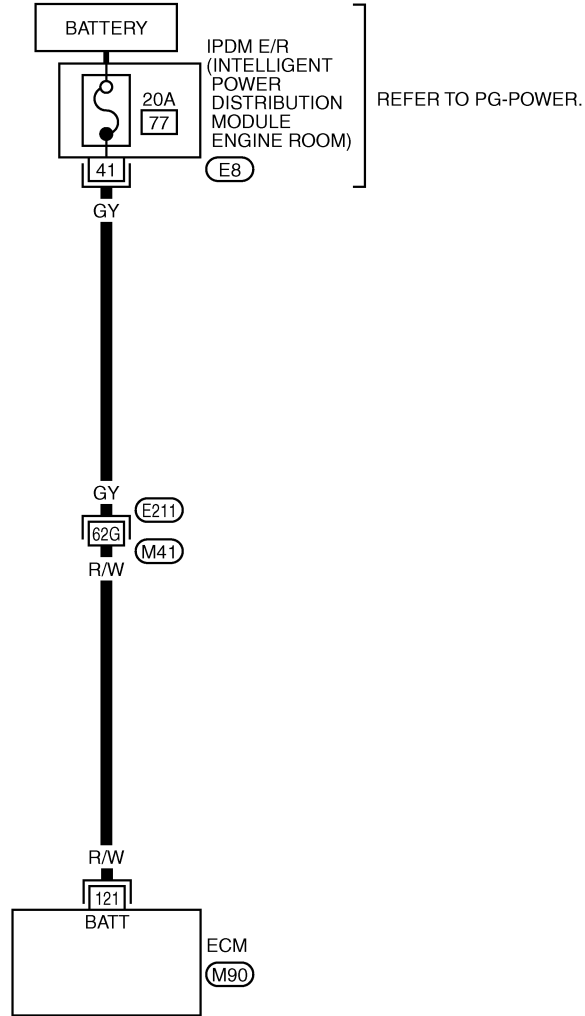

(M90)
B

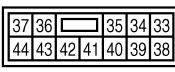

(E8)
W



REFER TO THE FOLLOWING.
 (E211) -SUPER MULTIPLE
 JUNCTION (SMJ)

TBWM0250E

DTC P1065 ECM POWER SUPPLY

[VQ35DE]

Specification data are reference values and are measured between each terminal and ground.

CAUTION:

Do not use ECM ground terminals when measuring input/output voltage. Doing so may result in damage to the ECM's transistor. Use a ground other than ECM terminals, such as the ground.

TER-MINAL NO.	WIRE COLOR	ITEM	CONDITION	DATA (DC Voltage)
121	R/W	Power supply for ECM (Back-up)	[Ignition switch OFF]	BATTERY VOLTAGE (11 - 14V)

Diagnostic Procedure

ABS006T1

1. CHECK ECM POWER SUPPLY

1. Turn ignition switch OFF.
2. Disconnect ECM harness connector.
3. Check voltage between ECM terminal 121 and ground with CONSULT-II or tester.

Voltage: Battery voltage

OK or NG

- OK >> GO TO 3.
- NG >> GO TO 2.

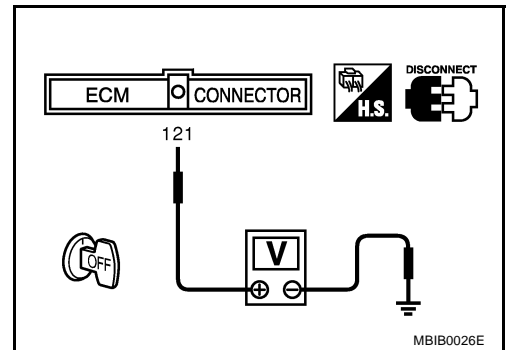

2. DETECT MALFUNCTIONING PART

Check the following.

- Harness connectors M41, E211
- 20A fuse
- IPDM E/R harness connector E8
- Harness for open or short between ECM and IPDM E/R

>> Repair open circuit or short to ground in harness or connectors.

3. CHECK INTERMITTENT INCIDENT

Refer to [EC-135, "TROUBLE DIAGNOSIS FOR INTERMITTENT INCIDENT"](#).

OK or NG

- OK >> GO TO 4.
- NG >> Repair or replace harness or connectors.

4. PERFORM DTC CONFIRMATION PROCEDURE

With CONSULT-II

1. Turn ignition switch ON.
2. Select "SELF DIAG RESULTS" mode with CONSULT-II.
3. Touch "ERASE".
4. **Perform DTC Confirmation Procedure.**
See [EC-404](#) .
5. Is the 1st trip DTC P1065 displayed again?

With GST

1. Turn ignition switch ON.
2. Select MODE 4 with GST.
3. Touch "ERASE".
4. **Perform DTC Confirmation Procedure.**
See [EC-404](#) .
5. Is the 1st trip DTC P1065 displayed again?

Yes or No

Yes >> GO TO 5.

No >> **INSPECTION END**

5. REPLACE ECM

1. Replace ECM.
2. Perform initialization of IVIS(NATS) system and registration of all IVIS(NATS) ignition key IDs. Refer to [BL-208, "ECM Re-communicating Function"](#) .
3. Perform [EC-49, "Accelerator Pedal Released Position Learning"](#) .
4. Perform [EC-49, "Throttle Valve Closed Position Learning"](#) .
5. Perform [EC-49, "Idle Air Volume Learning"](#) .

>> **INSPECTION END**

DTC P1111, P1136 IVT CONTROL SOLENOID VALVE

PFP:23796

Component Description

ABS006T2

Intake valve timing control solenoid valve is activated by ON/OFF pulse duty (ratio) signals from the ECM.

The intake valve timing control solenoid valve changes the oil amount and direction of flow through intake valve timing control unit or stops oil flow.

The longer pulse width advances valve angle.

The shorter pulse width retards valve angle.

When ON and OFF pulse widths become equal, the solenoid valve stops oil pressure flow to fix the intake valve angle at the control position.

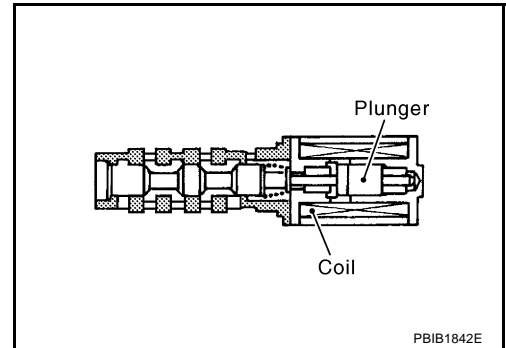

CONSULT-II Reference Value in Data Monitor Mode

ABS006T3

Specification data are reference values.

MONITOR ITEM	CONDITION		SPECIFICATION
INT/V SOL (B1) INT/V SOL (B2)	<ul style="list-style-type: none"> ● Engine: After warming up ● Shift lever: P or N 	Idle	0% - 2%
	<ul style="list-style-type: none"> ● Air conditioner switch: OFF ● No-load 	When revving engine up to 2,000 rpm quickly	Approx. 0% - 50%

On Board Diagnosis Logic

ABS006T4

DTC No.	Trouble diagnosis name	DTC detecting condition	Possible cause
P1111 1111 (Bank 1)	Intake valve timing control solenoid valve circuit	An improper voltage is sent to the ECM through intake valve timing control solenoid valve.	<ul style="list-style-type: none"> ● Harness or connectors (Intake valve timing control solenoid valve circuit is open or shorted.) ● Intake valve timing control solenoid valve
P1136 1136 (Bank 2)			

DTC Confirmation Procedure

ABS006T5

NOTE:

If DTC Confirmation Procedure has been previously conducted, always turn ignition switch OFF and wait at least 10 seconds before conducting the next test.

WITH CONSULT-II

1. Turn ignition switch ON.
2. Select "DATA MONITOR" mode with CONSULT-II.
3. Start engine and let it idle for 5 seconds.
4. If 1st trip DTC is detected, go to [EC-412, "Diagnostic Procedure"](#)

DATA MONITOR	
MONITOR	NO DTC
ENG SPEED	XXX rpm

SEF058Y

WITH GST

Following the procedure "WITH CONSULT-II" above.

DTC P1111, P1136 IVT CONTROL SOLENOID VALVE

[VQ35DE]

Wiring Diagram BANK 1

ABS006T6

EC-IVCB1-01

— : DETECTABLE LINE FOR DTC
- - - : NON-DETECTABLE LINE FOR DTC

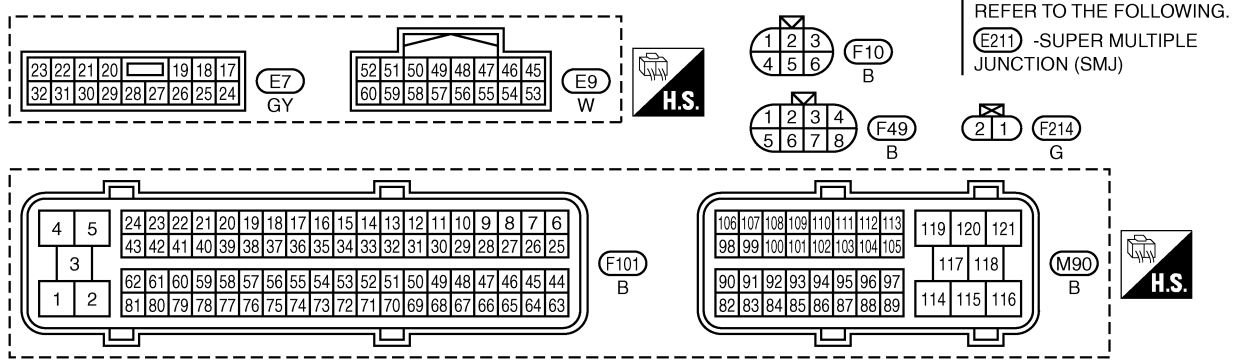
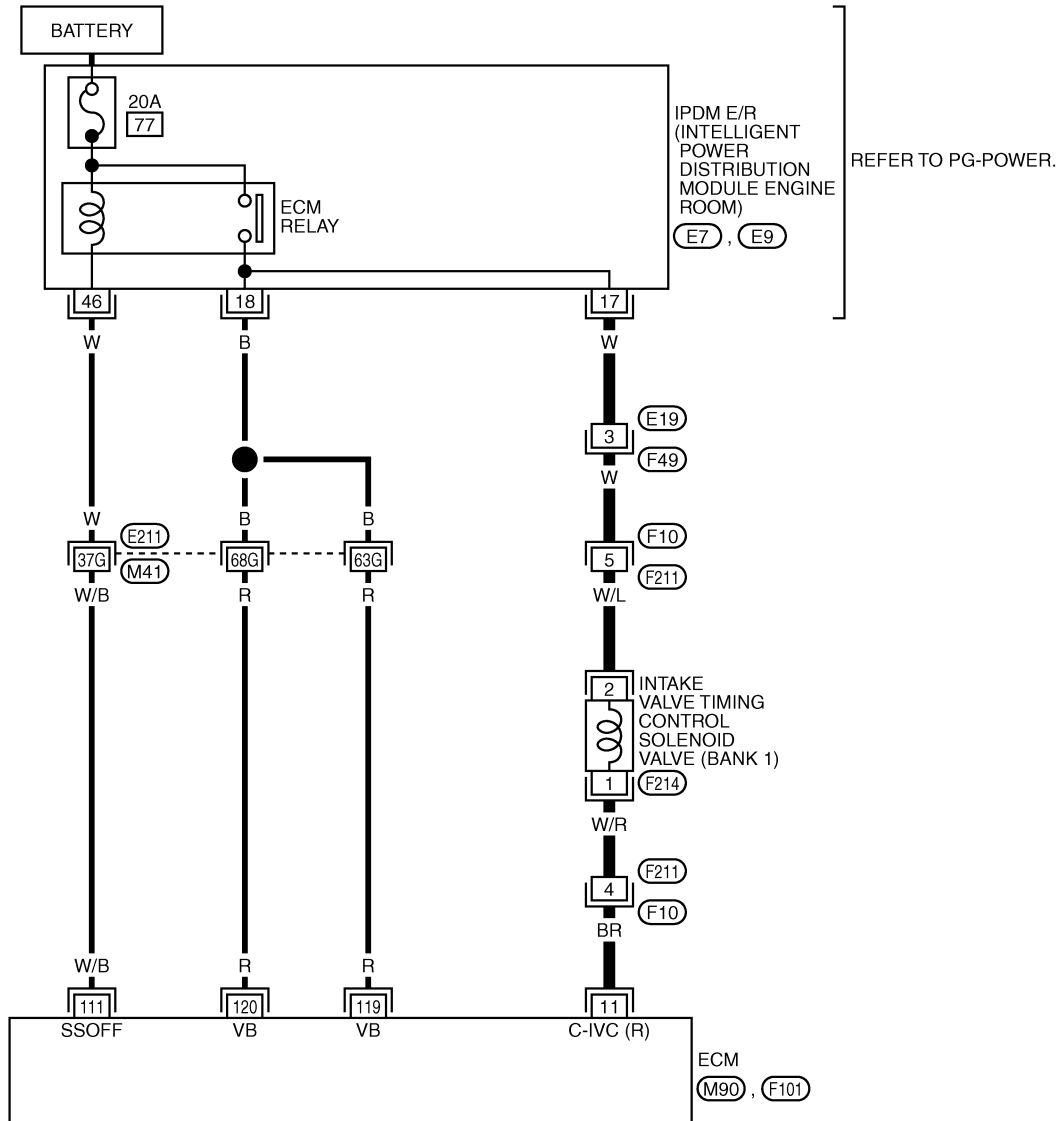

DTC P1111, P1136 IVT CONTROL SOLENOID VALVE

[VQ35DE]

Specification data are reference values and are measured between each terminal and ground.
Pulse signal is measured by CONSULT-II.

CAUTION:

Do not use ECM ground terminals when measuring input/output voltage. Doing so may result in damage to the ECM's transistor. Use a ground other than ECM terminals, such as the ground.

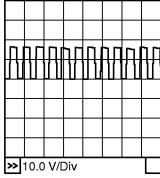
TER-MINAL NO.	WIRE COLOR	ITEM	CONDITION	DATA (DC Voltage)
11	BR	Intake valve timing control solenoid valve (bank 1)	[Engine is running] <ul style="list-style-type: none"> ● Warm-up condition ● Idle speed 	BATTERY VOLTAGE (11 - 14V)
			[Engine is running] <ul style="list-style-type: none"> ● Warm-up condition ● When revving engine up to 2,500 rpm quickly 	7 - 12V★ 

PBIB1790E

★: Average voltage for pulse signal (Actual pulse signal can be confirmed by oscilloscope.)

DTC P1111, P1136 IVT CONTROL SOLENOID VALVE

[VQ35DE]

BANK 2

EC-IVCB2-01

— : DETECTABLE LINE FOR DTC
 — : NON-DETECTABLE LINE FOR DTC

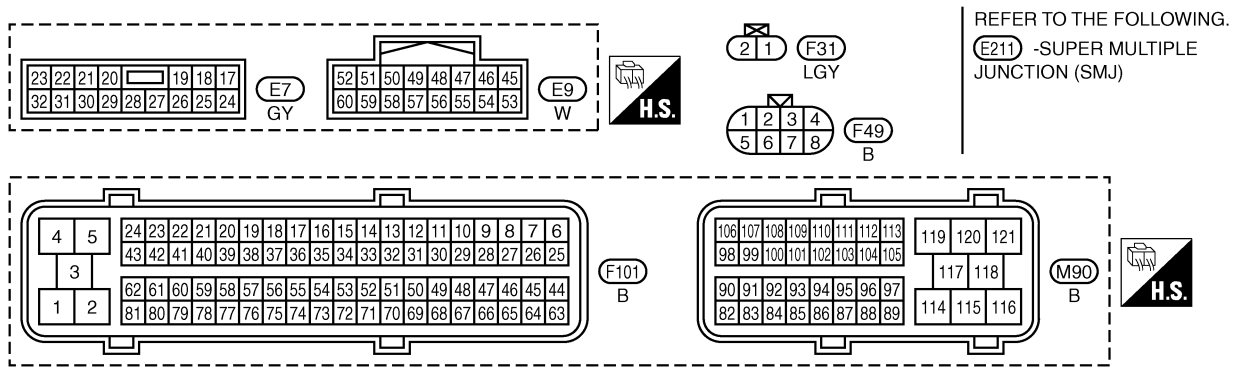
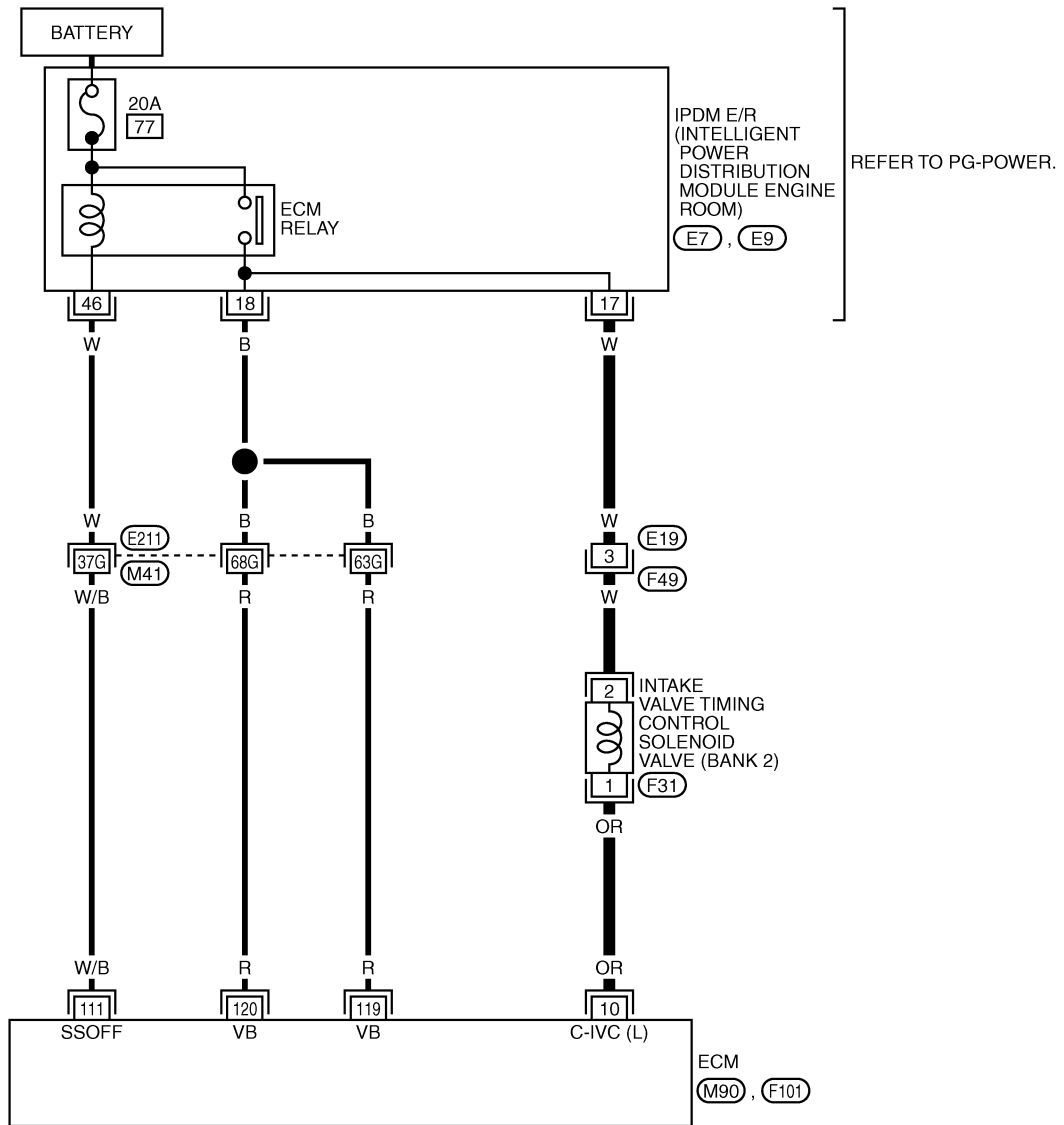

TBWM0282E

DTC P1111, P1136 IVT CONTROL SOLENOID VALVE

[VQ35DE]

Specification data are reference values and are measured between each terminal and ground.
Pulse signal is measured by CONSULT-II.

CAUTION:

Do not use ECM ground terminals when measuring input/output voltage. Doing so may result in damage to the ECM's transistor. Use a ground other than ECM terminals, such as the ground.

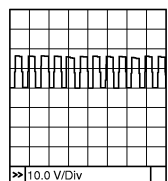
TER-MINAL NO.	WIRE COLOR	ITEM	CONDITION	DATA (DC Voltage)
10	OR	Intake valve timing control solenoid valve (bank 2)	[Engine is running] ● Warm-up condition ● Idle speed	BATTERY VOLTAGE (11 - 14V)
			[Engine is running] ● Warm-up condition ● When revving engine up to 2,500 rpm quickly	7 - 12V★  PBIB1790E

★: Average voltage for pulse signal (Actual pulse signal can be confirmed by oscilloscope.)

Diagnostic Procedure

ABS00677

1. CHECK INTAKE VALVE TIMING CONTROL SOLENOID VALVE POWER SUPPLY CIRCUIT

- Turn ignition switch OFF.
- Disconnect intake valve timing control solenoid valve harness connector.

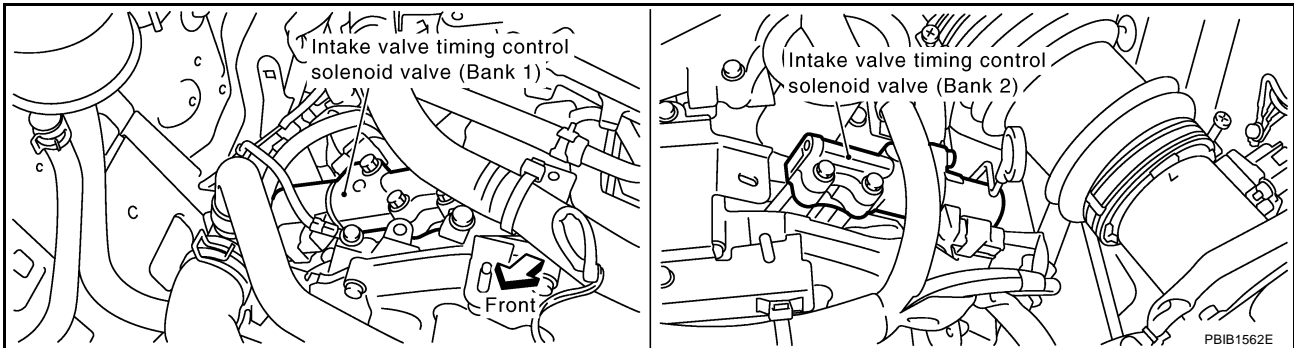

- Turn ignition switch ON.
- Check voltage between intake valve timing control solenoid valve terminal 2 and ground with CONSULT-II or tester.

Voltage: Battery voltage

OK or NG

- OK >> GO TO 3.
- NG >> GO TO 2.

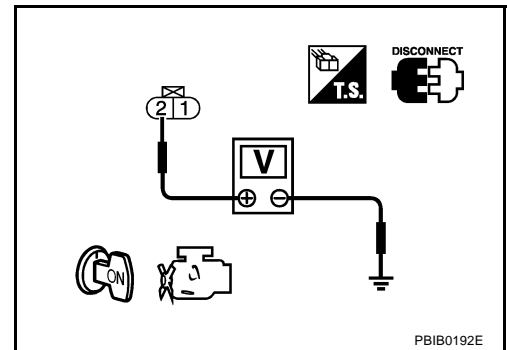

2. DETECT MALFUNCTIONING PART

Check the following.

- Harness connectors E19, F49
- Harness connectors F10, F211
- IPDM E/R harness connector E7
- Harness for open or short between intake valve timing control solenoid valve and IPDM E/R

>> Repair harness or connectors.

3. CHECK INTAKE VALVE TIMING CONTROL SOLENOID VALVE OUTPUT SIGNAL CIRCUIT FOR OPEN AND SHORT

1. Turn ignition switch OFF.
2. Disconnect ECM harness connector.
3. Check harness continuity between ECM terminal 11 (bank 1) or 10 (bank 2) and intake valve timing control solenoid valve terminal 1. Refer to Wiring Diagram.

Continuity should exist.

4. Also check harness for short to ground and short to power.

OK or NG

- OK >> GO TO 5.
- NG >> GO TO 4.

4. DETECT MALFUNCTIONING PART

Check the following.

- Harness connectors F211, F10
- Harness for open and short between ECM and intake valve timing control solenoid valve

>> Repair open circuit or short to ground or short to power in harness or connectors.

5. CHECK INTAKE VALVE TIMING CONTROL SOLENOID VALVE

Refer to [EC-414, "Component Inspection"](#) .

OK or NG

- OK >> GO TO 6.
- NG >> Replace intake valve timing control solenoid valve.

6. CHECK INTERMITTENT INCIDENT

Refer to [EC-135, "TROUBLE DIAGNOSIS FOR INTERMITTENT INCIDENT"](#) .

For wiring diagram, refer to [EC-303](#) for CKP sensor (POS), [EC-309](#) and [EC-311](#) for CMP sensor (PHASE).

>> **INSPECTION END**

Component Inspection INTAKE VALVE TIMING CONTROL SOLENOID VALVE

1. Disconnect intake valve timing control solenoid valve harness connector.
2. Check resistance between intake valve timing control solenoid valve terminals as follows.

Terminals	Resistance
1 and 2	7.0 - 7.5Ω at 20°C (68°F)
1 or 2 and ground	∞Ω (Continuity should not exist)

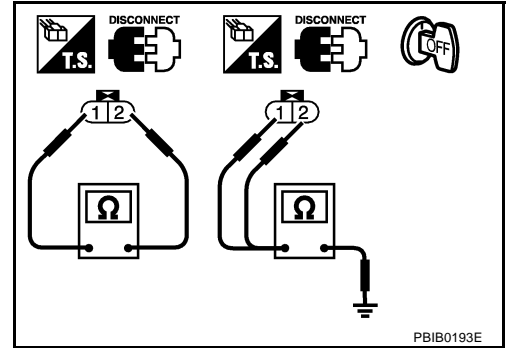

Removal and Installation INTAKE VALVE TIMING CONTROL SOLENOID VALVE

Refer to [EM-63, "TIMING CHAIN"](#) .

DTC P1121 ELECTRIC THROTTLE CONTROL ACTUATOR

PFP:16119

Component Description

ABS006TA

Electric throttle control actuator consists of throttle control motor, throttle position sensor, etc. The throttle control motor is operated by the ECM and it opens and closes the throttle valve. The throttle position sensor detects the throttle valve position, and the opening and closing speed of the throttle valve and feeds the voltage signals to the ECM. The ECM judges the current opening angle of the throttle valve from these signals and the ECM controls the throttle control motor to make the throttle valve opening angle properly in response to driving condition.

On Board Diagnosis Logic

ABS006TB

This self-diagnosis has the one trip detection logic.

DTC No.	Trouble diagnosis name	DTC detecting condition		Possible cause
P1121 1121	Electric throttle control actuator	A)	Electric throttle control actuator does not function properly due to the return spring malfunction.	● Electric throttle control actuator
		B)	Throttle valve opening angle in fail-safe mode is not in specified range.	
		C)	ECM detect the throttle valve is stuck open.	

FAIL-SAFE MODE

When the malfunction is detected, the ECM enters fail-safe mode and the MIL lights up.

Detected items	Engine operating condition in fail-safe mode
Malfunction A	The ECM controls the electric throttle actuator by regulating the throttle opening around the idle position. The engine speed will not rise more than 2,000 rpm.
Malfunction B	ECM controls the electric throttle control actuator by regulating the throttle opening to 20 degrees or less.
Malfunction C	While the vehicle is driving, it slows down gradually by fuel cut. After the vehicle stops, the engine stalls. The engine can restart in N or P position, and engine speed will not exceed 1,000 rpm or more.

DTC Confirmation Procedure

ABS006TC

NOTE:

- Perform **PROCEDURE FOR MALFUNCTION A AND B** first. If the DTC cannot be confirmed, perform **PROCEDURE FOR MALFUNCTION C**.
- If DTC Confirmation Procedure has been previously conducted, always turn ignition switch OFF and wait at least 10 seconds before conducting the next test.

PROCEDURE FOR MALFUNCTION A AND B

With CONSULT-II

1. Turn ignition switch ON and wait at least 1 second.
2. Select "DATA MONITOR" mode with CONSULT-II.
3. Shift selector lever to D position and wait at least 3 seconds.
4. Shift selector lever to P position.
5. Turn ignition switch OFF, wait at least 10 seconds.
6. Turn ignition switch ON and wait at least 1 second.
7. Shift selector lever to D position, and wait at least 3 seconds.
8. Shift selector lever to P position.
9. Turn ignition switch OFF, wait at least 10 seconds, and then turn ON.
10. If DTC is detected, go to [EC-416, "Diagnostic Procedure"](#) .

DATA MONITOR	
MONITOR	NO DTC
ENG SPEED	XXX rpm

SEF058Y

With GST

Follow the procedure "WITH CONSULT-II" above.

PROCEDURE FOR MALFUNCTION C

① With CONSULT-II

1. Turn ignition switch ON and wait at least 1 second.
2. Select "DATA MONITOR" mode with CONSULT-II.
3. Shift selector lever to D position and wait at least 3 seconds.
4. Shift selector lever to P or N position.
5. Start engine and let it idle for 3 seconds.
6. If DTC is detected, go to [EC-416, "Diagnostic Procedure"](#) .

DATA MONITOR	
MONITOR	NO DTC
ENG SPEED	XXX rpm

SEF058Y

② With GST

Follow the procedure "WITH CONSULT-II" above.

Diagnostic Procedure

ABS0067D

1. CHECK ELECTRIC THROTTLE CONTROL ACTUATOR VISUALLY

1. Remove the intake air duct.
2. Check if a foreign matter is caught between the throttle valve and the housing.

OK or NG

- OK >> GO TO 2.
 NG >> Remove the foreign matter and clean the electric throttle control actuator inside.

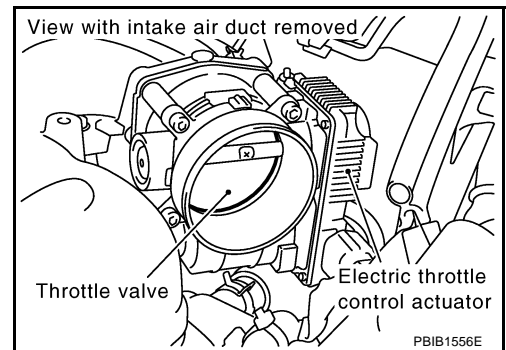

2. REPLACE ELECTRIC THROTTLE CONTROL ACTUATOR

1. Replace the electric throttle control actuator.
2. Perform [EC-49, "Throttle Valve Closed Position Learning"](#) .
3. Perform [EC-49, "Idle Air Volume Learning"](#) .

>> INSPECTION END

DTC P1122 ELECTRIC THROTTLE CONTROL FUNCTION

PFP:16119

Description

ABS006TE

NOTE:

If DTC P1122 is displayed with DTC P1121 or 1126, first perform the trouble diagnosis for DTC P1121 or P1126. Refer to [EC-415](#) or [EC-423](#).

Electric throttle control actuator consists of throttle control motor, throttle position sensor, etc.

The throttle control motor is operated by the ECM and it opens and closes the throttle valve.

The current opening angle of the throttle valve is detected by the throttle position sensor and it provides feedback to the ECM to control the throttle control motor to make the throttle valve opening angle properly in response to driving condition.

On Board Diagnosis Logic

ABS006TF

This self-diagnosis has the one trip detection logic.

DTC No.	Trouble diagnosis name	DTC detecting condition	Possible cause
P1122 1122	Electric throttle control performance problem	Electric throttle control function does not operate properly.	<ul style="list-style-type: none"> ● Harness or connectors (Throttle control motor circuit is open or shorted) ● Electric throttle control actuator

FAIL-SAFE MODE

When the malfunction is detected, ECM enters fail-safe mode and the MIL lights up.

Engine operating condition in fail-safe mode

ECM stops the electric throttle control actuator control, throttle valve is maintained at a fixed opening (approx. 5 degrees) by the return spring.

DTC Confirmation Procedure

ABS006TG

NOTE:

If DTC Confirmation Procedure has been previously conducted, always turn ignition switch OFF and wait at least 10 seconds before conducting the next test.

TESTING CONDITION:

Before performing the following procedure, confirm that battery voltage is more than 11V when the engine is running.

WITH CONSULT-II

1. Turn ignition switch ON and wait at least 2 seconds.
2. Select "DATA MONITOR" mode with CONSULT-II.
3. Start engine and let it idle for 5 seconds.
4. If DTC is detected, go to [EC-419, "Diagnostic Procedure"](#).

DATA MONITOR	
MONITOR	NO DTC
ENG SPEED	XXX rpm

SEF058Y

WITH GST

Follow the procedure "WITH CONSULT-II" above.

DTC P1122 ELECTRIC THROTTLE CONTROL FUNCTION

[VQ35DE]

ABS006TH

Wiring Diagram

EC-ETC1-01

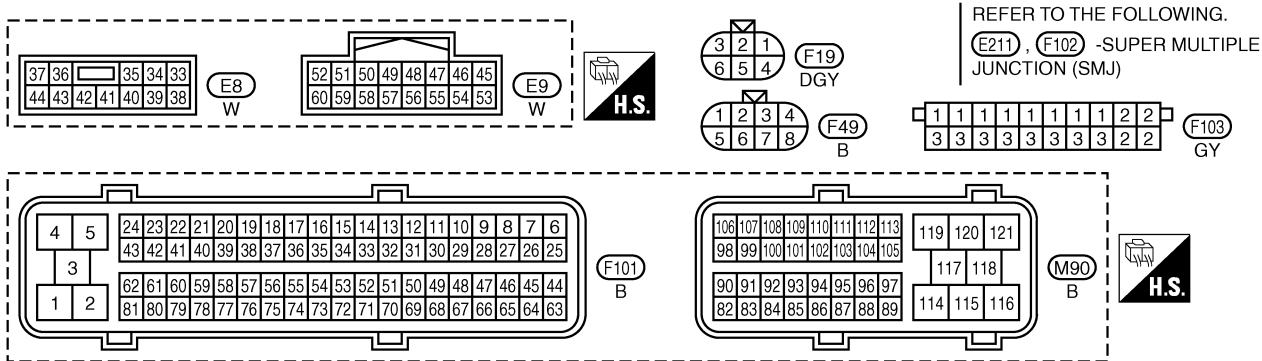
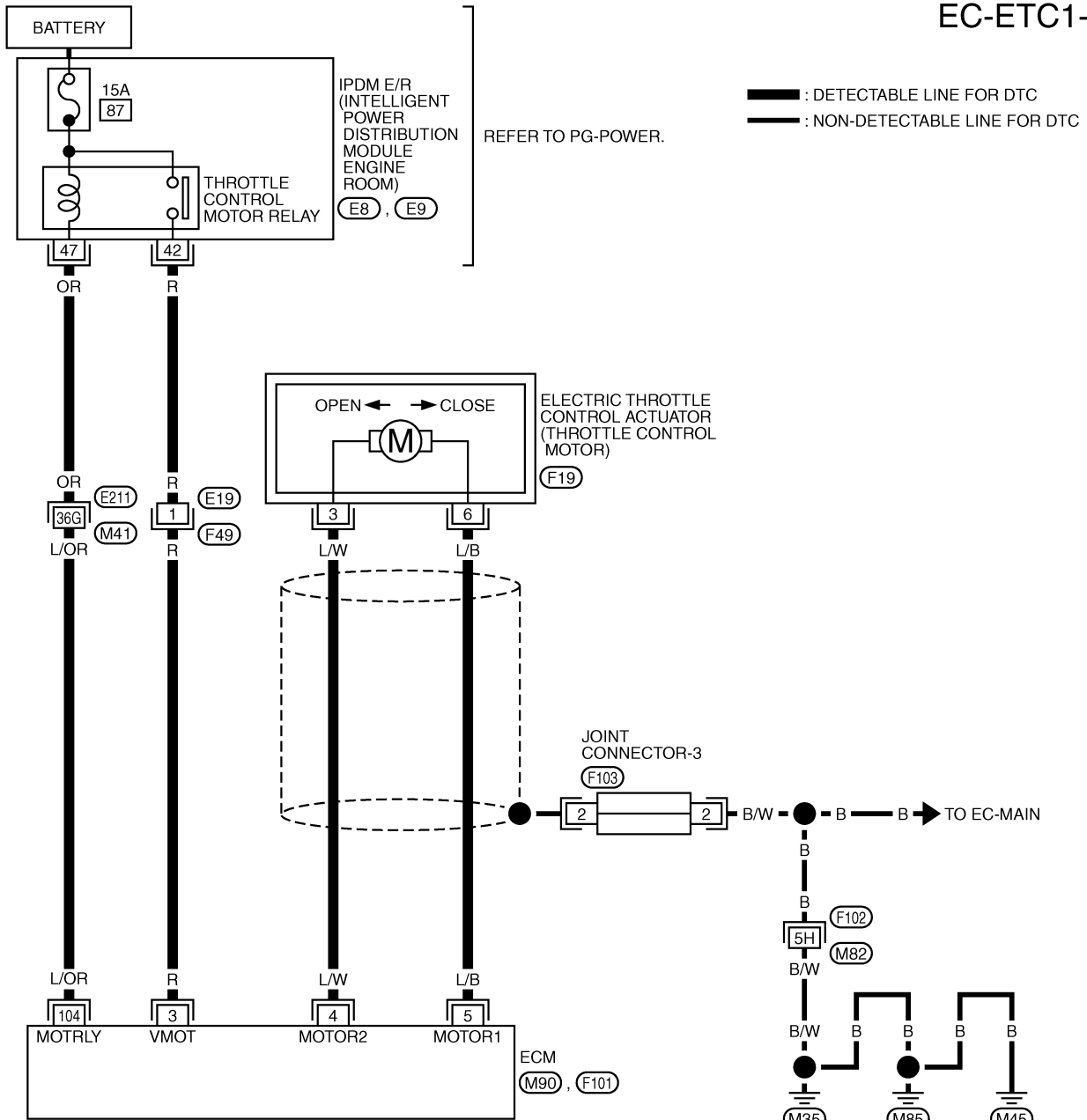

TBWM0369E

DTC P1122 ELECTRIC THROTTLE CONTROL FUNCTION

[VQ35DE]

Specification data are reference values and are measured between each terminal and ground.
Pulse signal is measured by CONSULT-II.

CAUTION:

Do not use ECM ground terminals when measuring input/output voltage. Doing so may result in damage to the ECM's transistor. Use a ground other than ECM terminals, such as the ground.

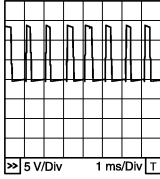
TER-MINAL NO.	WIRE COLOR	ITEM	CONDITION	DATA (DC Voltage)
3	R	Throttle control motor relay power supply	[Ignition switch: ON]	BATTERY VOLTAGE (11 - 14V)
4	L/W	Throttle control motor (Close)	[Ignition switch: ON] ● Engine stopped ● Shift lever: D ● Accelerator pedal: Released	0 - 14V★  PBIB1104E
5	L/B	Throttle control motor (Open)	[Ignition switch: ON] ● Engine stopped ● Shift lever: D ● Accelerator pedal: Fully depressed	0 - 14V★  PBIB1105E
104	L/OR	Throttle control motor relay	[Ignition switch: OFF]	BATTERY VOLTAGE (11 - 14V)
			[Ignition switch: ON]	0 - 1.0V

Diagnostic Procedure

ABS00CHM

1. CHECK GROUND CONNECTIONS

1. Turn ignition switch OFF
2. Loosen and retighten ground three screws on the body. Refer to [EC-141, "Ground Inspection"](#).

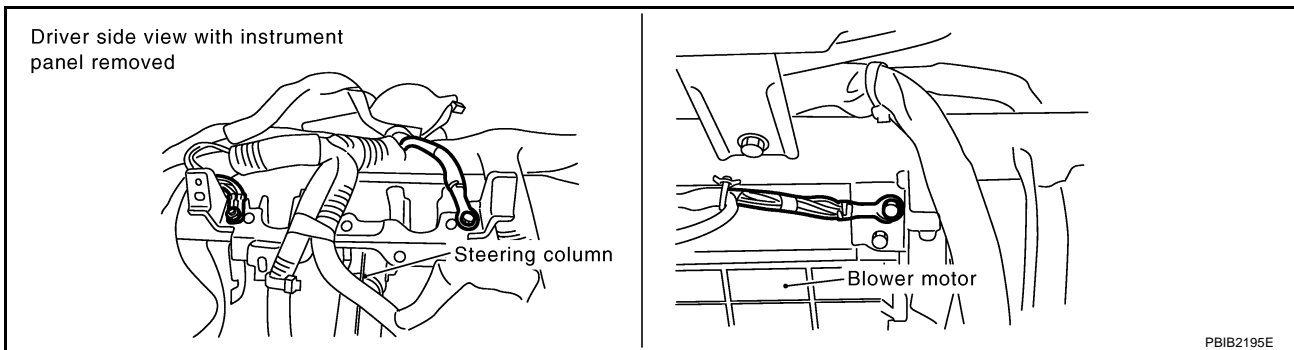

OK or NG

- OK >> GO TO 2.
- NG >> Repair or replace ground connections.

2. CHECK THROTTLE CONTROL MOTOR RELAY INPUT SIGNAL CIRCUIT-I

1. Check voltage between ECM terminal 3 and ground under the following conditions with CONSULT-II or tester.

Ignition switch	Voltage
OFF	Approximately 0V
ON	Battery voltage (11 - 14V)

OK or NG

- OK >> GO TO 10.
- NG >> GO TO 3.

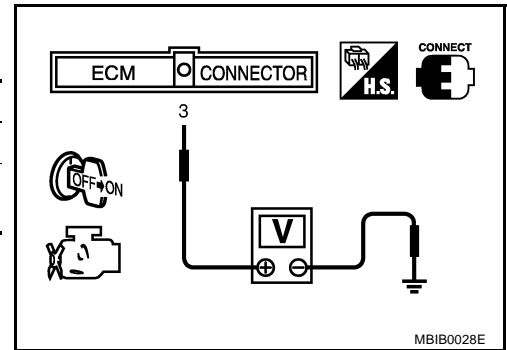

3. CHECK THROTTLE CONTROL MOTOR RELAY INPUT SIGNAL CIRCUIT-II

1. Turn ignition switch OFF.
2. Disconnect ECM harness connector.
3. Disconnect IPDM E/R harness connector E8.
4. Check continuity between ECM terminal 3 and IPDM E/R terminal 42. Refer to Wiring Diagram.

Continuity should exist.

5. Also check harness for short to ground and short to power.

OK or NG

- OK >> GO TO 5.
- NG >> GO TO 4.

4. DETECT MALFUNCTIONING PART

Check the following.

- Harness connectors E19, F49
- Harness for open or short between ECM and IPDM E/R

>> Repair open circuit or short to ground or short to power in harness or connectors.

5. CHECK THROTTLE CONTROL MOTOR RELAY POWER SUPPLY CIRCUIT-I

1. Reconnect all harness connectors disconnected.
2. Turn ignition switch OFF.
3. Check voltage between ECM terminal 104 and ground with CONSULT-II or tester.

Voltage: Battery voltage

OK or NG

- OK >> GO TO 9.
- NG >> GO TO 6.

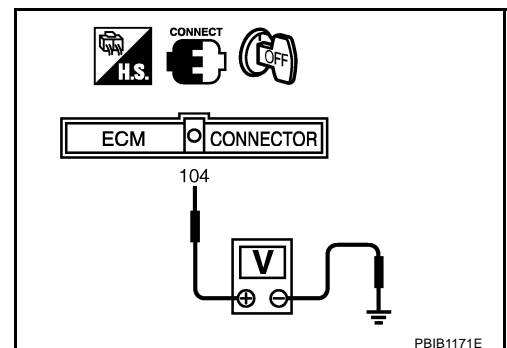

6. CHECK THROTTLE CONTROL MOTOR RELAY POWER SUPPLY CIRCUIT-II

1. Disconnect ECM harness connector.
2. Disconnect IPDM E/R harness connector E9.
3. Check continuity between ECM terminal 104 and IPDM E/R terminal 47.
Refer to Wiring Diagram.

Continuity should exist.

4. Also check harness for short to ground and short to power.

OK or NG

- OK >> GO TO 8.
- NG >> GO TO 7.

7. DETECT MALFUNCTIONING PART

Check the following.

- Harness connectors E211, M41
- Harness for open or short between ECM and IPDM E/R

>> Repair open circuit or short to ground or short to power in harness or connectors.

8. CHECK FUSE

1. Disconnect 15A fuse.
2. Check 15A fuse for blown.

OK or NG

- OK >> GO TO 9.
- NG >> Replace 15A fuse.

9. CHECK INTERMITTENT INCIDENT

Refer to [EC-135. "TROUBLE DIAGNOSIS FOR INTERMITTENT INCIDENT"](#) .

OK or NG

- OK >> Replace IPDM E/R. Refer to [PG-18. "IPDM E/R \(INTELLIGENT POWER DISTRIBUTION MODULE ENGINE ROOM\)"](#) .
- NG >> Repair or replace harness or connectors.

10. CHECK THROTTLE CONTROL MOTOR OUTPUT SIGNAL CIRCUIT FOR OPEN OR SHORT

1. Turn ignition switch OFF.
2. Disconnect electric throttle control actuator harness connector.
3. Disconnect ECM harness connector.
4. Check harness continuity between the following terminals.
Refer to Wiring Diagram.

Electric throttle control actuator terminal	ECM terminal	Continuity
3	5	Should not exist
	4	Should exist
6	5	Should exist
	4	Should not exist

5. Also check harness for short to ground and short to power.

OK or NG

- OK >> GO TO 11.
- NG >> Repair or replace.

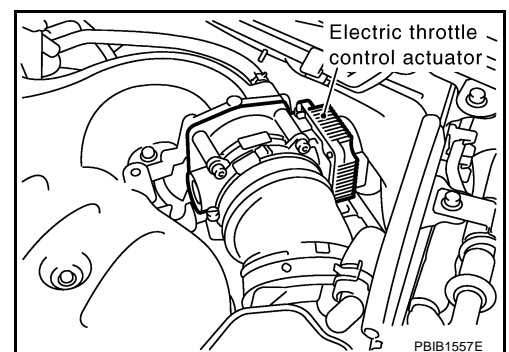

11. CHECK ELECTRIC THROTTLE CONTROL ACTUATOR VISUALLY

1. Remove the intake air duct.
2. Check if foreign matter is caught between the throttle valve and the housing.

OK or NG

OK >> GO TO 12.

NG >> Remove the foreign matter and clean the electric throttle control actuator inside.

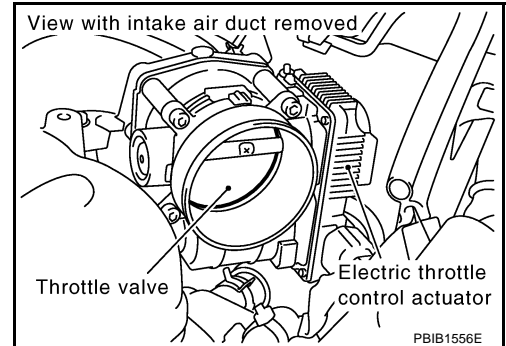

12. CHECK THROTTLE CONTROL MOTOR

Refer to [EC-422, "Component Inspection"](#) .

OK or NG

OK >> GO TO 13.

NG >> GO TO 14.

13. CHECK INTERMITTENT INCIDENT

Refer to [EC-135, "TROUBLE DIAGNOSIS FOR INTERMITTENT INCIDENT"](#) .

OK or NG

OK >> GO TO 14.

NG >> Repair or replace harness or connectors.

14. REPLACE ELECTRIC THROTTLE CONTROL ACTUATOR

1. Replace the electric throttle control actuator.
2. Perform [EC-49, "Throttle Valve Closed Position Learning"](#) .
3. Perform [EC-49, "Idle Air Volume Learning"](#) .

>> INSPECTION END

Component Inspection THROTTLE CONTROL MOTOR

ABS006TJ

1. Disconnect electric throttle control actuator harness connector.
2. Check resistance between terminals 3 and 6.

Resistance: Approximately 1 - 15 Ω [at 25 °C (77°F)]

3. If NG, replace electric throttle control actuator and go to next step.
4. Perform [EC-49, "Throttle Valve Closed Position Learning"](#) .
5. Perform [EC-49, "Idle Air Volume Learning"](#) .

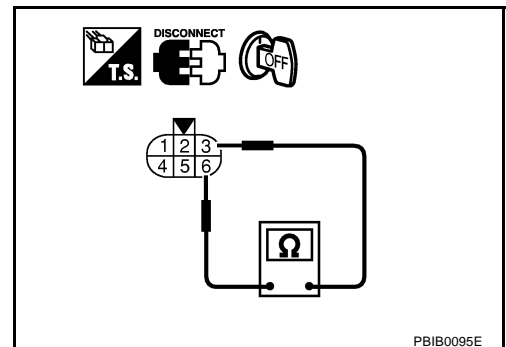

ABS006TK

Removal and Installation ELECTRIC THROTTLE CONTROL ACTUATOR

Refer to [EM-19, "INTAKE MANIFOLD COLLECTOR"](#) .

DTC P1124, P1126 THROTTLE CONTROL MOTOR RELAY

[VQ35DE]

DTC P1124, P1126 THROTTLE CONTROL MOTOR RELAY

PFP:16119

Component Description

ABS006TL

Power supply for the throttle control motor is provided to the ECM via throttle control motor relay. The throttle control motor relay is ON/OFF controlled by the ECM. When the ignition switch is turned ON, the ECM sends an ON signal to throttle control motor relay and battery voltage is provided to the ECM. When the ignition switch is turned OFF, the ECM sends an OFF signal to throttle control motor relay and battery voltage is not provided to the ECM.

CONSULT-II Reference Value in Data Monitor Mode

ABS006TM

Specification data are reference values.

MONITOR ITEM	CONDITION	SPECIFICATION
THRTL RELAY	● Ignition switch: ON	ON

On Board Diagnosis Logic

ABS006TN

These self-diagnoses have the one trip detection logic.

DTC No.	Trouble diagnosis name	DTC detecting condition	Possible cause
P1124 1124	Throttle control motor relay circuit short	ECM detects the throttle control motor relay is stuck ON.	<ul style="list-style-type: none">● Harness or connectors (Throttle control motor relay circuit is shorted)● Throttle control motor relay
P1126 1126	Throttle control motor relay circuit open	ECM detects a voltage of power source for throttle control motor is excessively low.	<ul style="list-style-type: none">● Harness or connectors (Throttle control motor relay circuit is open)● Throttle control motor relay

FAIL-SAFE MODE

When the malfunction is detected, ECM enters fail-safe mode and the MIL lights up.

Engine operating condition in fail-safe mode

ECM stops the electric throttle control actuator control, throttle valve is maintained at a fixed opening (approx. 5 degrees) by the return spring.

DTC Confirmation Procedure

ABS006TO

NOTE:

If DTC Confirmation Procedure has been previously conducted, always turn ignition switch OFF and wait at least 10 seconds before conducting the next test.

PROCEDURE FOR DTC P1124

TESTING CONDITION:

Before performing the following procedure, confirm that battery voltage is more than 8V.

④ With CONSULT-II

1. Turn ignition switch ON and wait at least 1 second.
2. Select "DATA MONITOR" mode with CONSULT-II.
3. If DTC is detected, go to [EC-426, "Diagnostic Procedure"](#).

DATA MONITOR	
MONITOR	NO DTC
ENG SPEED	XXX rpm

SEF058Y

 **With GST**

Follow the procedure "With CONSULT-II" above.

PROCEDURE FOR DTC P1126 **With CONSULT-II**

1. Turn ignition switch ON and wait at least 2 seconds.
2. Select "DATA MONITOR" mode with CONSULT-II.
3. Start engine and let it idle for 5 seconds.
4. If DTC is detected, go to [EC-426, "Diagnostic Procedure"](#) .

DATA MONITOR	
MONITOR	NO DTC
ENG SPEED	XXX rpm

SEF058Y

 **With GST**

Follow the procedure "With CONSULT-II" above.

DTC P1124, P1126 THROTTLE CONTROL MOTOR RELAY

[VQ35DE]

Wiring Diagram

ABS006TP

EC-ETC2-01

A
EC
C
D
E
F
G
H
I
J
K
L
M

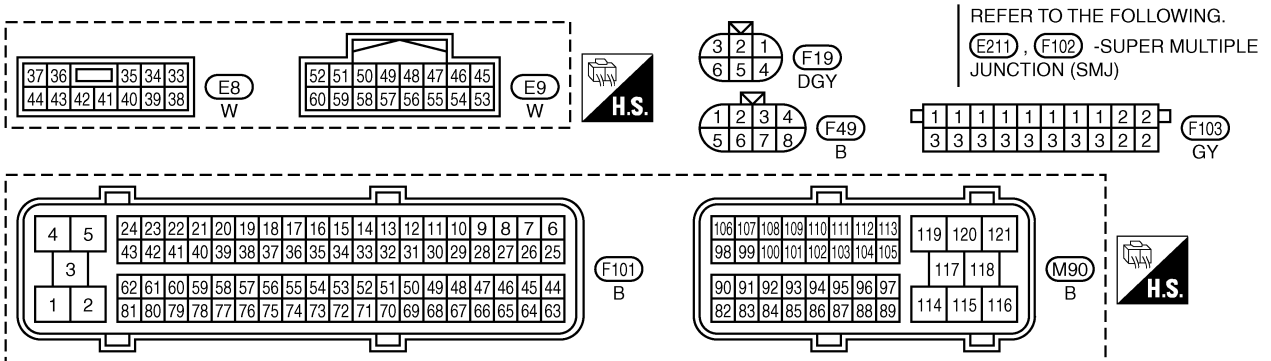
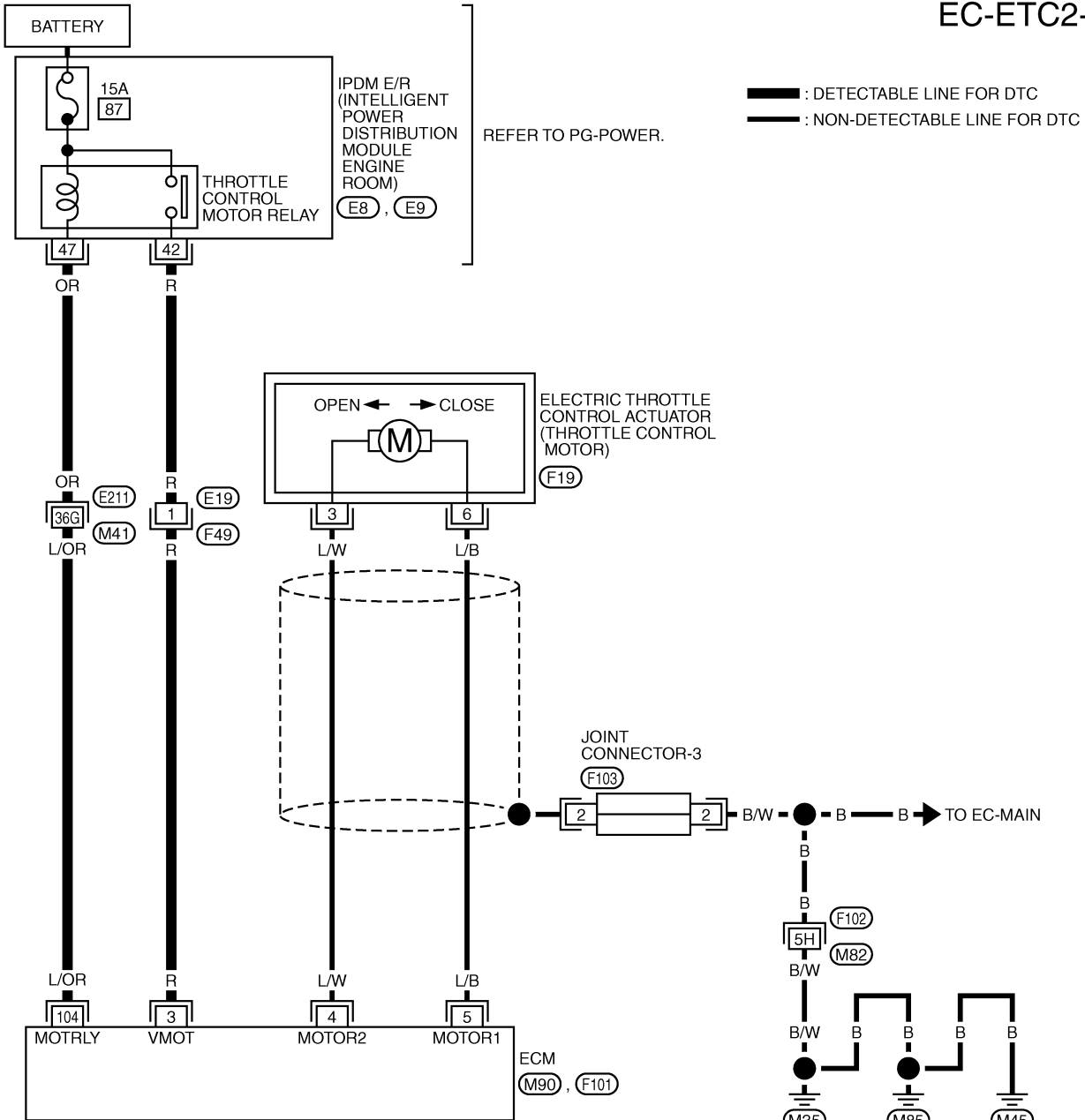

TBWM0304E

DTC P1124, P1126 THROTTLE CONTROL MOTOR RELAY

[VQ35DE]

Specification data are reference values and are measured between each terminal and ground.

CAUTION:

Do not use ECM ground terminals when measuring input/output voltage. Doing so may result in damage to the ECM's transistor. Use a ground other than ECM terminals, such as the ground.

TER-MINAL NO.	WIRE COLOR	ITEM	CONDITION	DATA (DC Voltage)
3	R	Throttle control motor relay power supply	[Ignition switch: ON]	BATTERY VOLTAGE (11 - 14V)
104	L/OR	Throttle control motor relay	[Ignition switch: OFF]	BATTERY VOLTAGE (11 - 14V)
			[Ignition switch: ON]	0 - 1.0V

Diagnostic Procedure

ABS006TQ

1. CHECK THROTTLE CONTROL MOTOR RELAY POWER SUPPLY CIRCUIT-I

1. Turn ignition switch OFF.
2. Check voltage between ECM terminal 104 and ground with CONSULT-II or tester.

Voltage: Battery voltage

OK or NG

- OK >> GO TO 5.
NG >> GO TO 2.

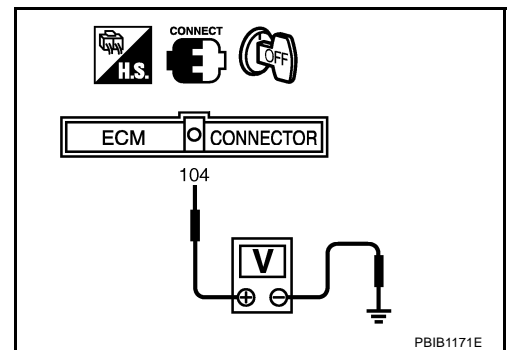

2. CHECK THROTTLE CONTROL MOTOR RELAY POWER SUPPLY CIRCUIT-II

1. Disconnect ECM harness connector.
2. Disconnect IPDM E/R harness connector E9.
3. Check continuity between ECM terminal 104 and IPDM E/R terminal 47. Refer to Wiring Diagram.

Continuity should exist.

4. Also check harness for short to ground and short to power.

OK or NG

- OK >> GO TO 4.
NG >> GO TO 3.

3. DETECT MALFUNCTIONING PART

Check the following.

- Harness connectors E211, M41
- Harness for open or short between ECM and IPDM E/R

>> Repair open circuit or short to ground or short to power in harness or connectors.

4. CHECK FUSE

1. Disconnect 15A fuse.
2. Check 15A fuse for blown.

OK or NG

- OK >> GO TO 8.
 NG >> Replace 15A fuse.

5. CHECK THROTTLE CONTROL MOTOR RELAY INPUT SIGNAL CIRCUIT-I

1. Check voltage between ECM terminal 3 and ground under the following conditions with CONSULT-II or tester.

Ignition switch	Voltage
OFF	Approximately 0V
ON	Battery voltage (11 - 14V)

OK or NG

- OK >> GO TO 8.
 NG >> GO TO 6.

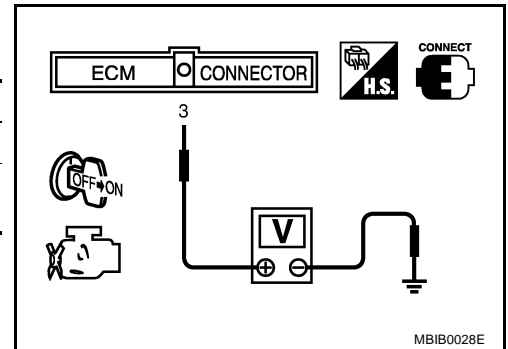

6. CHECK THROTTLE CONTROL MOTOR RELAY INPUT SIGNAL CIRCUIT-II

1. Turn ignition switch OFF.
2. Disconnect ECM harness connector.
3. Disconnect IPDM E/R harness connector E8.
4. Check continuity between ECM terminal 3 and IPDM E/R terminal 42. Refer to Wiring Diagram.

Continuity should exist.

5. Also check harness for short to ground and short to power.

OK or NG

- OK >> GO TO 8.
 NG >> GO TO 7.

7. DETECT MALFUNCTIONING PART

Check the following.

- Harness connectors E19, F49
- Harness for open or short between ECM and IPDM E/R

>> Repair open circuit or short to ground or short to power in harness or connectors.

8. CHECK INTERMITTENT INCIDENT

Refer to [EC-135, "TROUBLE DIAGNOSIS FOR INTERMITTENT INCIDENT"](#) .

OK or NG

- OK >> Replace IPDM E/R. Refer to [PG-18, "IPDM E/R \(INTELLIGENT POWER DISTRIBUTION MODULE ENGINE ROOM\)"](#) .
 NG >> Repair or replace harness or connectors.

DTC P1128 THROTTLE CONTROL MOTOR

PFP:16119

Component Description

ABS006TR

The throttle control motor is operated by the ECM and it opens and closes the throttle valve. The current opening angle of the throttle valve is detected by the throttle position sensor and it provides feedback to the ECM to control the throttle control motor to make the throttle valve opening angle properly in response to driving condition.

On Board Diagnosis Logic

ABS006TS

This self-diagnosis has the one trip detection logic.

DTC No.	Trouble diagnosis name	DTC detecting condition	Possible cause
P1128 1128	Throttle control motor circuit short	ECM detects short in both circuits between ECM and throttle control motor.	<ul style="list-style-type: none"> ● Harness or connectors (Throttle control motor circuit is shorted.) ● Electric throttle control actuator (Throttle control motor)

FAIL-SAFE MODE

When the malfunction is detected, the ECM enters fail-safe mode and the MIL lights up.

Engine operating condition in fail-safe mode

ECM stops the electric throttle control actuator control, throttle valve is maintained at a fixed opening (approx. 5 degrees) by the return spring.

DTC Confirmation Procedure

ABS006TT

NOTE:

If DTC Confirmation Procedure has been previously conducted, always turn ignition switch OFF and wait at least 10 seconds before conducting the next test.

WITH CONSULT-II

1. Turn ignition switch ON and wait at least 2 seconds.
2. Select "DATA MONITOR" mode with CONSULT-II.
3. Start engine and let it idle for 5 seconds.
4. If DTC is detected, go to [EC-430, "Diagnostic Procedure"](#) .

DATA MONITOR	
MONITOR	NO DTC
ENG SPEED	XXX rpm

SEF058Y

WITH GST

Follow the procedure "WITH CONSULT-II" above.

DTC P1128 THROTTLE CONTROL MOTOR

[VQ35DE]

ABS006TU

Wiring Diagram

EC-ETC3-01

A
EC
C
D
E
F
G
H
I
J
K
L
M

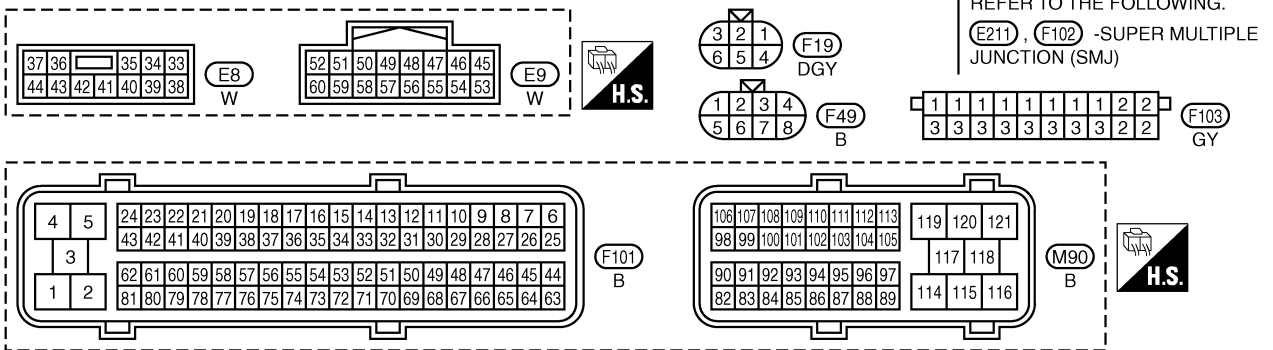
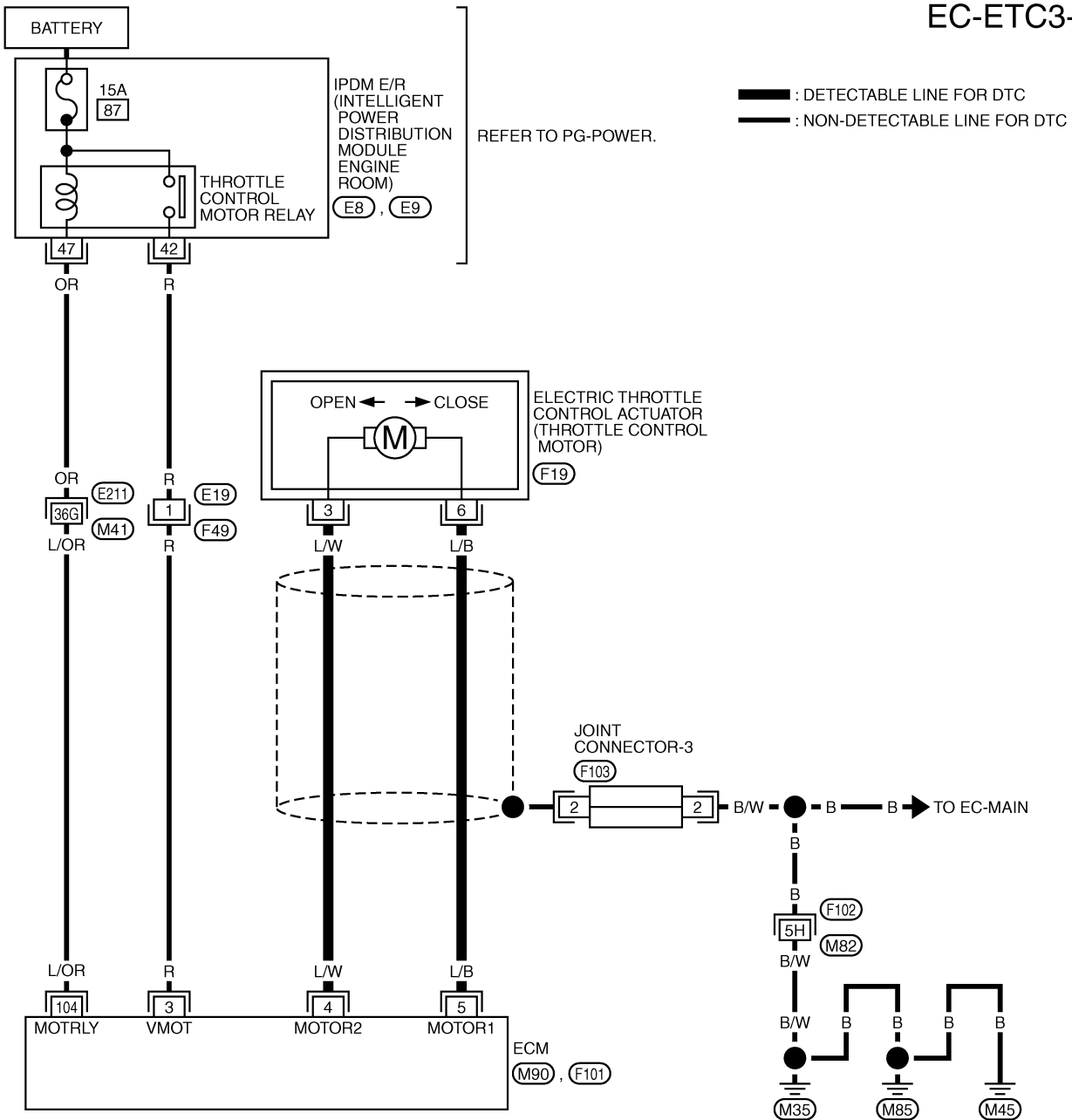

TBWM0305E

DTC P1128 THROTTLE CONTROL MOTOR

[VQ35DE]

Specification data are reference values and are measured between each terminal and ground.
Pulse signal is measured by CONSULT-II.

CAUTION:

Do not use ECM ground terminals when measuring input/output voltage. Doing so may result in damage to the ECM's transistor. Use a ground other than ECM terminals, such as the ground.

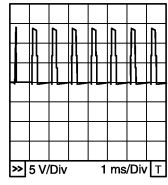
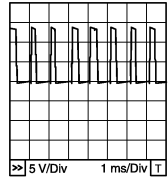
TER-MINAL NO.	WIRE COLOR	ITEM	CONDITION	DATA (DC Voltage)
4	L/W	Throttle control motor (Close)	<p>[Ignition switch: ON]</p> <ul style="list-style-type: none"> ● Engine stopped ● Shift lever: D ● Accelerator pedal: Released 	<p>0 - 14V★</p>  <p>PBIB1104E</p>
5	L/B	Throttle control motor (Open)	<p>[Ignition switch: ON]</p> <ul style="list-style-type: none"> ● Engine stopped ● Shift lever: D ● Accelerator pedal: Fully depressed 	<p>0 - 14V★</p>  <p>PBIB1105E</p>

★: Average voltage for pulse signal (Actual pulse signal can be confirmed by oscilloscope.)

Diagnostic Procedure

ABS00CHN

1. CHECK GROUND CONNECTIONS

1. Turn ignition switch OFF.
2. Loosen and retighten ground three screws on the body. Refer to [EC-141, "Ground Inspection"](#).

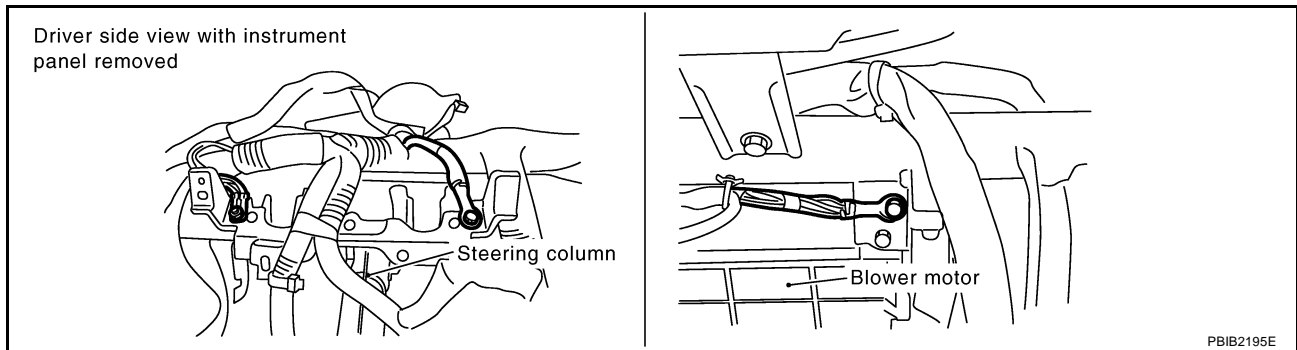

OK or NG

- OK >> GO TO 2.
NG >> Repair or replace ground connections.

2. CHECK THROTTLE CONTROL MOTOR OUTPUT SIGNAL CIRCUIT FOR OPEN OR SHORT

1. Disconnect electric throttle control actuator harness connector.
2. Disconnect ECM harness connector.
3. Check harness continuity between the following terminals. Refer to Wiring Diagram.

Electric throttle control actuator terminal	ECM terminal	Continuity
3	5	Should not exist
	4	Should exist
6	5	Should exist
	4	Should not exist

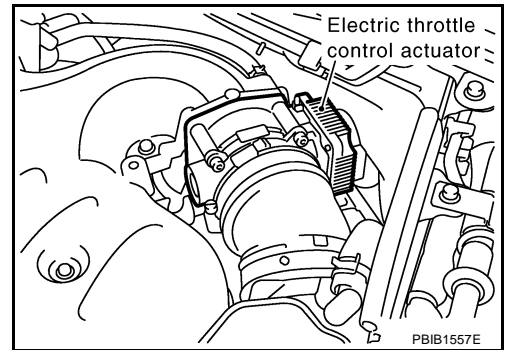

4. Also check harness for short to ground and short to power.

OK or NG

- OK >> GO TO 3.
- NG >> Repair or replace.

3. CHECK THROTTLE CONTROL MOTOR

Refer to [EC-431, "Component Inspection"](#) .

OK or NG

- OK >> GO TO 4.
- NG >> GO TO 5.

4. CHECK INTERMITTENT INCIDENT

Refer to [EC-135, "TROUBLE DIAGNOSIS FOR INTERMITTENT INCIDENT"](#) .

OK or NG

- OK >> GO TO 5.
- NG >> Repair or replace harness or connectors.

5. REPLACE ELECTRIC THROTTLE CONTROL ACTUATOR

1. Replace the electric throttle control actuator.
2. Perform [EC-49, "Throttle Valve Closed Position Learning"](#) .
3. Perform [EC-49, "Idle Air Volume Learning"](#) .

>> INSPECTION END

Component Inspection THROTTLE CONTROL MOTOR

ABS006TW

1. Disconnect electric throttle control actuator harness connector.
2. Check resistance between terminals 3 and 6.

Resistance: Approximately 1 - 15 Ω [at 25 °C (77°F)]

3. If NG, replace electric throttle control actuator and go to next step.
4. Perform [EC-49, "Throttle Valve Closed Position Learning"](#) .
5. Perform [EC-49, "Idle Air Volume Learning"](#) .

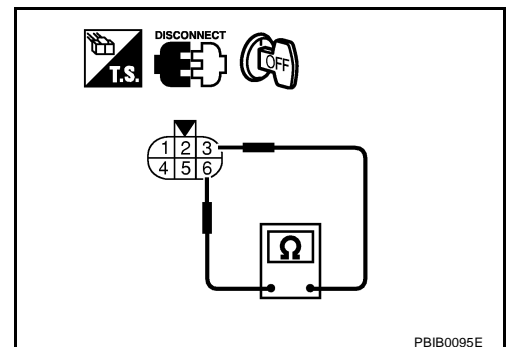

PBIB0095E

Removal and Installation ELECTRIC THROTTLE CONTROL ACTUATOR

ABS006TX

Refer to [EM-19, "INTAKE MANIFOLD COLLECTOR"](#) .

DTC P1143, P1163 HO2S1

PFP:22690

Component Description

ABS006TY

The heated oxygen sensor 1 is placed into the exhaust manifold. It detects the amount of oxygen in the exhaust gas compared to the outside air. The heated oxygen sensor 1 has a closed-end tube made of ceramic zirconia. The zirconia generates voltage from approximately 1V in richer conditions to 0V in leaner conditions. The heated oxygen sensor 1 signal is sent to the ECM. The ECM adjusts the injection pulse duration to achieve the ideal air-fuel ratio. The ideal air-fuel ratio occurs near the radical change from 1 to 0V.

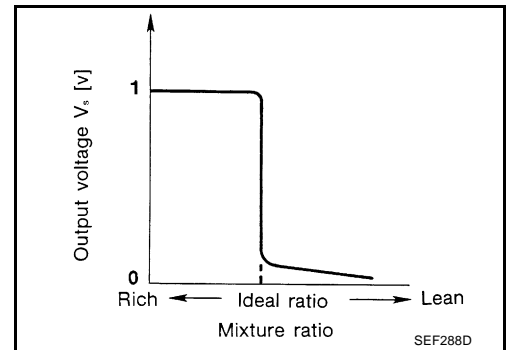
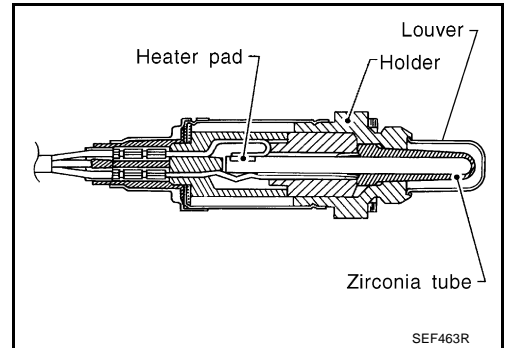

CONSULT-II Reference Value in Data Monitor Mode

ABS006TZ

Specification data are reference values.

MONITOR ITEM	CONDITION		SPECIFICATION
HO2S1 (B1) HO2S1 (B2)	● Engine: After warming up	Maintaining engine speed at 2,000 rpm	0 - 0.3V ↔ Approx. 0.6 - 1.0V
HO2S1 MNTR (B1) HO2S1 MNTR (B2)			LEAN ↔ RICH Changes more than 5 times during 10 seconds.

On Board Diagnosis Logic

ABS006U0

To judge the malfunction, the output from the heated oxygen sensor 1 is monitored to determine whether the rich output is sufficiently high and whether the lean output is sufficiently low. When both the outputs are shifting to the lean side, the malfunction will be detected.

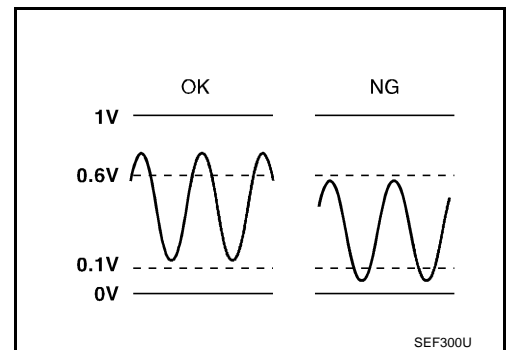

DTC No.	Trouble diagnosis name	DTC detecting condition	Possible cause
P1143 1143 (Bank 1)	Heated oxygen sensor 1 lean shift monitoring	The maximum and minimum voltage from the sensor are not reached to the specified voltages.	<ul style="list-style-type: none"> ● Heated oxygen sensor 1 ● Heated oxygen sensor 1 heater ● Fuel pressure ● Injector ● Intake air leaks
P1163 1163 (Bank 2)			

DTC Confirmation Procedure

CAUTION:

Always drive vehicle at a safe speed.

NOTE:

If DTC Confirmation Procedure has been previously conducted, always turn ignition switch OFF and wait at least 10 seconds before conducting the next test.

TESTING CONDITION:

- Always perform at a temperature above -10°C (14°F).
- Before performing following procedure, confirm that battery voltage is more than 11V at idle.

WITH CONSULT-II

1. Start engine and warm it up to normal operating temperature.
2. Stop engine and wait at least 10 seconds.
3. Turn ignition switch ON and select "HO2S1 (B1) P1143" of "HO2S1" or "HO2S1 (B2) P1163" of "HO2S1" in "DTC WORK SUPPORT" mode with CONSULT-II.
4. Touch "START".
5. Start engine and let it idle for at least 3 minutes.

NOTE:

Never raise engine speed above 3,600 rpm after this step. If the engine speed limit is exceeded, return to step 5.

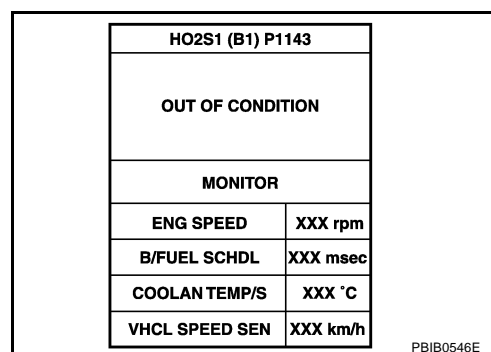

6. When the following conditions are met, "TESTING" will be displayed on the CONSULT-II screen. Maintain the conditions continuously until "TESTING" changes to "COMPLETED". (It will take approximately 40 seconds or more.)

ENG SPEED	1,000 - 3,100 rpm
Vehicle speed	Less than 100 km/h (62 MPH)
B/FUEL SCHDL	2.0 - 17.0 msec
Selector lever	Suitable position

If "TESTING" is not displayed after 5 minutes, retry from step 2.

7. Make sure that "OK" is displayed after touching "SELF-DIAG RESULTS". If "NG" is displayed, refer to [EC-435, "Diagnostic Procedure"](#).

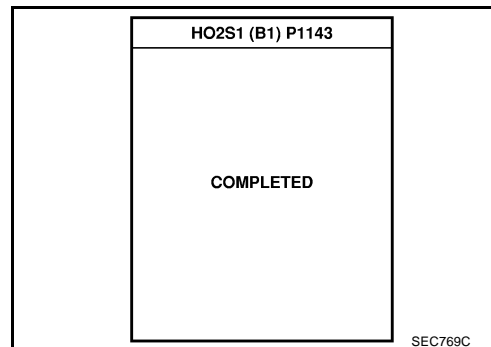
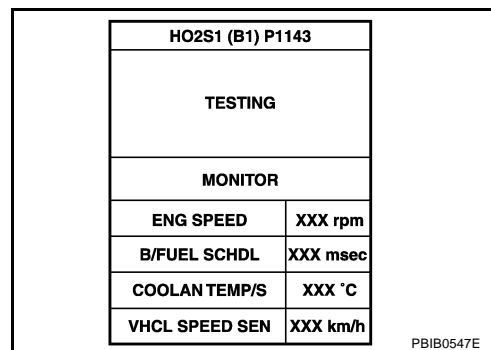

Overall Function Check

Use this procedure to check the overall function of the heated oxygen sensor 1 circuit. During this check, a DTC might not be confirmed.

WITH GST

1. Start engine and warm it up to normal operating temperature.
2. Set voltmeter probes between ECM terminal 35 [HO2S1(B1) signal] or 16 [HO2S1(B2) signal] and ground.
3. Check one of the following with engine speed held at 2,000 rpm constant under no load.
 - The maximum voltage is over 0.6V at least 1 time.
 - The minimum voltage is over 0.1V at least 1 time.
4. If NG, go to [EC-435, "Diagnostic Procedure"](#) .

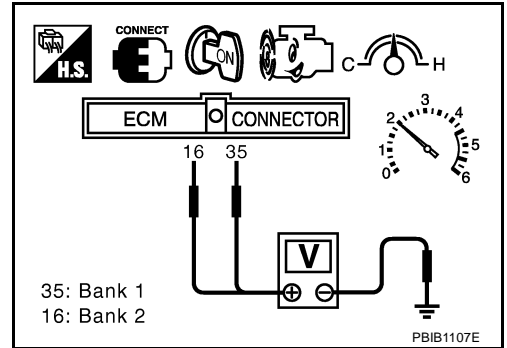

Diagnostic Procedure

1. CHECK GROUND CONNECTIONS

1. Turn ignition switch OFF.
2. Loosen and retighten ground three screws on the body. Refer to [EC-141, "Ground Inspection"](#) .

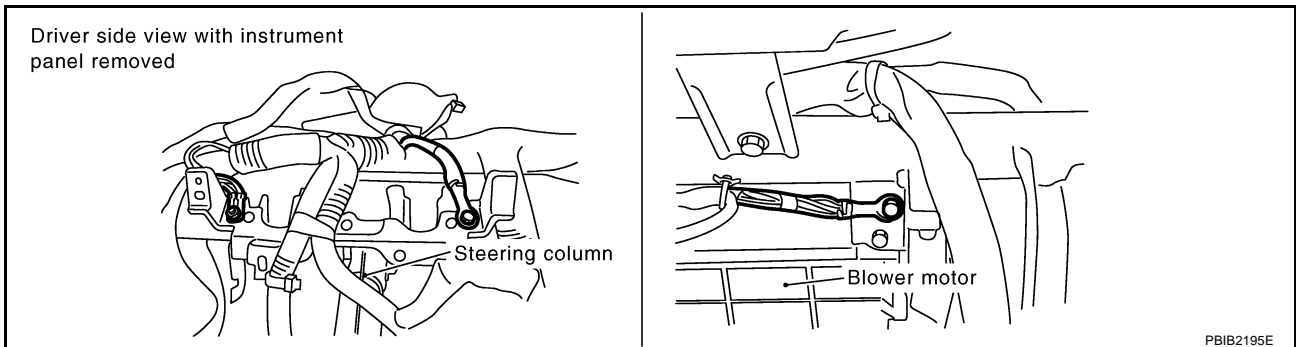

OK or NG

- OK >> GO TO 2.
- NG >> Repair or replace ground connections.

2. RETIGHTEN HEATED OXYGEN SENSOR 1

Loosen and retighten corresponding heated oxygen sensor 1.

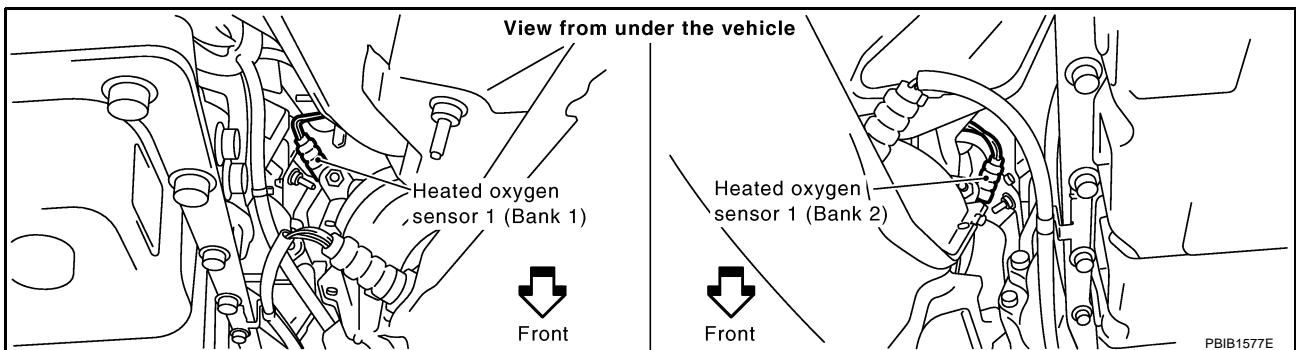

Tightening torque: 45 N-m (4.6 kg-m, 33 ft-lb)

>> GO TO 3.

A
EC
C
D
E
F
G
H
I
J
K
L
M

3. CLEAR THE SELF-LEARNING DATA

☑ With CONSULT-II

1. Start engine and warm it up to normal operating temperature.
2. Select "SELF-LEARNING CONT" in "WORK SUPPORT" mode with CONSULT-II.
3. Clear the self-learning control coefficient by touching "CLEAR".
4. Run engine for at least 10 minutes at idle speed.
Is the 1st trip DTC P0171 or P0174 detected?
Is it difficult to start engine?

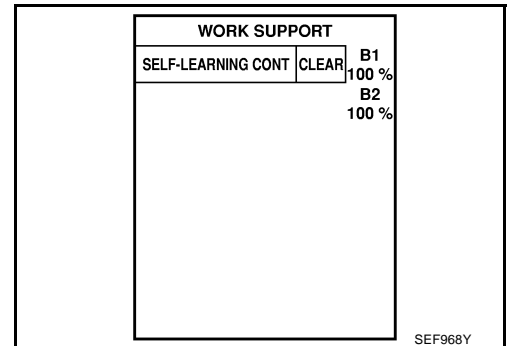

⊗ Without CONSULT-II

1. Start engine and warm it up to normal operating temperature.
2. Turn ignition switch OFF.
3. Disconnect mass air flow sensor harness connector, and restart and run engine for at least 5 seconds at idle speed.
4. Stop engine and reconnect mass air flow sensor harness connector.
5. Make sure DTC P0102 is displayed.
6. Erase the DTC memory. Refer to [EC-67, "HOW TO ERASE EMISSION-RELATED DIAGNOSTIC INFORMATION"](#).
7. Make sure DTC P0000 is displayed.
8. Run engine for at least 10 minutes at idle speed.
Is the 1st trip DTC P0171 or P0174 detected?
Is it difficult to start engine?

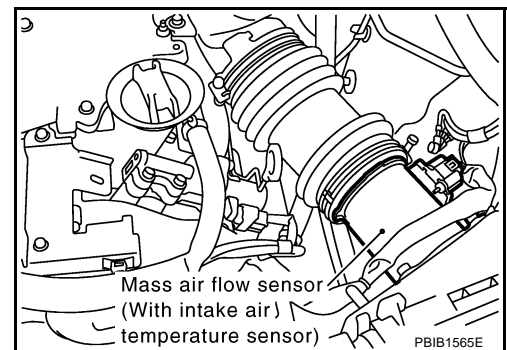

Yes or No

- Yes >> Perform trouble diagnosis for DTC P0171 or P0174. Refer to [EC-256](#).
- No >> GO TO 4.

4. CHECK HEATED OXYGEN SENSOR 1 HEATER

Refer to [EC-156, "Component Inspection"](#).

OK or NG

- OK >> GO TO 5.
- NG >> Replace malfunctioning heated oxygen sensor 1.

5. CHECK HEATED OXYGEN SENSOR 1

Refer to [EC-437, "Component Inspection"](#).

OK or NG

- OK >> GO TO 6.
- NG >> Replace malfunctioning heated oxygen sensor 1.

6. CHECK INTERMITTENT INCIDENT

Refer to [EC-135, "TROUBLE DIAGNOSIS FOR INTERMITTENT INCIDENT"](#).
For circuit, refer to [EC-207, "Wiring Diagram"](#).

>> INSPECTION END

Component Inspection HEATED OXYGEN SENSOR 1

With CONSULT-II

1. Start engine and warm it up to normal operating temperature.
2. Select "MANU TRIG" and adjust "TRIGGER POINT" to 100% in "DATA MONITOR" mode with CONSULT-II.
3. Select "HO2S1 (B1)/(B2)" and "HO2S1 MNTR (B1)/(B2)".
4. Hold engine speed at 2,000 rpm under no load during the following steps.
5. Touch "RECORD" on CONSULT-II screen.

DATA MONITOR	
MONITOR	NO DTC
ENG SPEED	XXX rpm
MAS A/F SE-B1	XXX V
COOLAN TEMP/S	XXX °C
HO2S1 (B1)	XXX V
HO2S1 MNTR (B1)	LEAN

SEF646Y

6. Check the following.
 - "HO2S1 MNTR (B1)/(B2)" in "DATA MONITOR" mode changes from "RICH" to "LEAN" to "RICH" 5 times in 10 seconds.
5 times (cycles) are counted as shown at right.
 - "HO2S1 (B1)/(B2)" voltage goes above 0.6V at least once.
 - "HO2S1 (B1)/(B2)" voltage goes below 0.3V at least once.
 - "HO2S1 (B1)/(B2)" voltage never exceeds 1.0V.

Bank 1	cycle	1	2	3	4	5	
	HO2S1 MNTR (B1)	R	L	R	L	R	L
Bank 2	cycle	1	2	3	4	5	
	HO2S1 MNTR (B2)	R	L	R	L	R	L

R means HO2S1
MNTR (B1)/(B2) indicates RICH
L means HO2S1
MNTR (B1)/(B2) indicates LEAN

SEF647Y

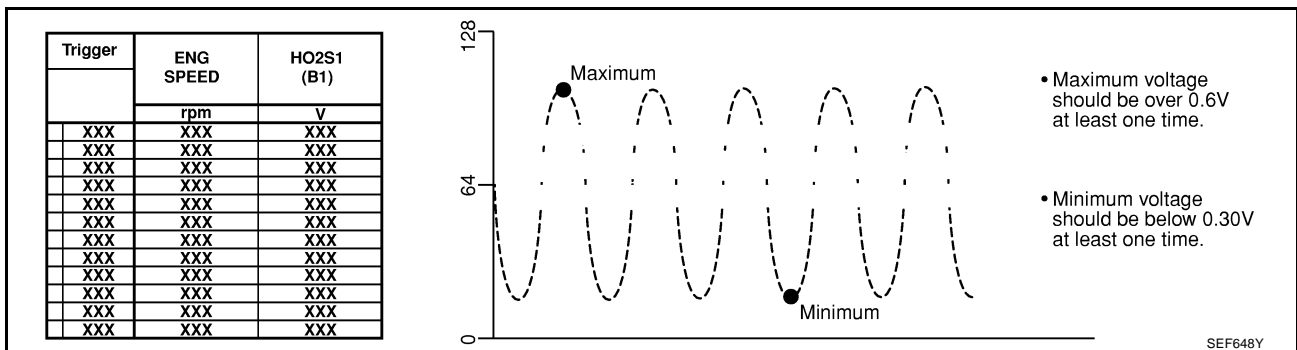

CAUTION:

- Discard any heated oxygen sensor which has been dropped from a height of more than 0.5 m (19.7 in) onto a hard surface such as a concrete floor; use a new one.
- Before installing new oxygen sensor, clean exhaust system threads using Oxygen Sensor Thread Cleaner tool J-43897-18 or J-43897-12 and approved anti-seize lubricant.

Without CONSULT-II

1. Start engine and warm it up to normal operating temperature.
2. Set voltmeter probes between ECM terminal 35 [HO2S1 (B1) signal] or 16 [HO2S1 (B2) signal] and ground.

3. Check the following with engine speed held at 2,000 rpm constant under no load.

- The voltage fluctuates between 0 to 0.3V and 0.6 to 1.0V more than 5 times within 10 seconds.
- The maximum voltage is over 0.6V at least one time.
- The minimum voltage is below 0.3V at least one time.
- The voltage never exceeds 1.0V.

1 time: 0 - 0.3V → 0.6 - 1.0V → 0 - 0.3V

2 times: 0 - 0.3V → 0.6 - 1.0V → 0 - 0.3V → 0.6 - 1.0V

CAUTION:

- Discard any heated oxygen sensor which has been dropped from a height of more than 0.5 m (19.7 in) onto a hard surface such as a concrete floor; use a new one.
- Before installing new oxygen sensor, clean exhaust system threads using Oxygen Sensor Thread Cleaner tool J-43897-18 or J-43897-12 and approved anti-seize lubricant.

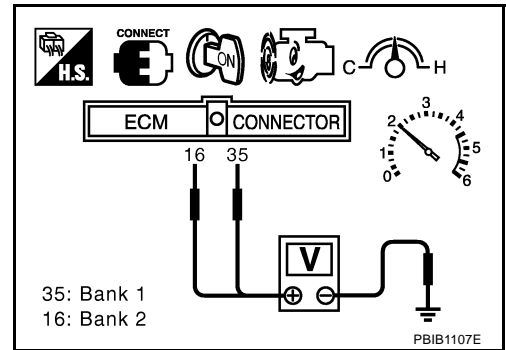

Removal and Installation HEATED OXYGEN SENSOR 1

ABS006U5

Refer to [EM-26, "EXHAUST MANIFOLD AND THREE WAY CATALYST"](#) .

DTC P1144, P1164 HO2S1

PF2:22690

Component Description

ABS006U6

The heated oxygen sensor 1 is placed into the exhaust manifold. It detects the amount of oxygen in the exhaust gas compared to the outside air. The heated oxygen sensor 1 has a closed-end tube made of ceramic zirconia. The zirconia generates voltage from approximately 1V in richer conditions to 0V in leaner conditions. The heated oxygen sensor 1 signal is sent to the ECM. The ECM adjusts the injection pulse duration to achieve the ideal air-fuel ratio. The ideal air-fuel ratio occurs near the radical change from 1 to 0V.

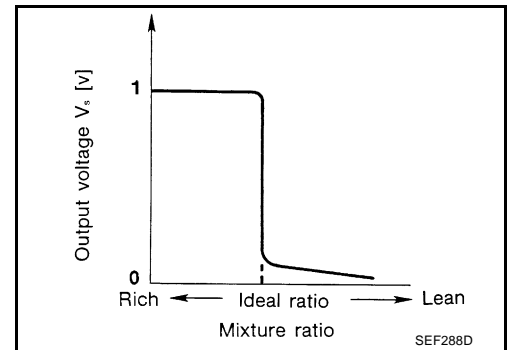
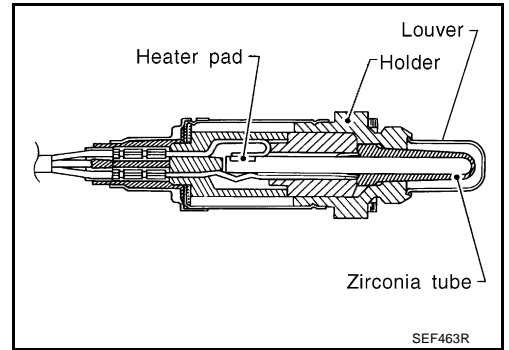

CONSULT-II Reference Value in Data Monitor Mode

ABS006U7

Specification data are reference values.

MONITOR ITEM	CONDITION		SPECIFICATION
HO2S1 (B1) HO2S1 (B2)	● Engine: After warming up	Maintaining engine speed at 2,000 rpm	0 - 0.3V ↔ Approx. 0.6 - 1.0V
HO2S1 MNTR (B1) HO2S1 MNTR (B2)			LEAN ↔ RICH Changes more than 5 times during 10 seconds.

On Board Diagnosis Logic

ABS006U8

To judge the malfunction, the output from the heated oxygen sensor 1 is monitored to determine whether the rich output is sufficiently high and lean output is sufficiently low. When both the outputs are shifting to the rich side, the malfunction will be detected.

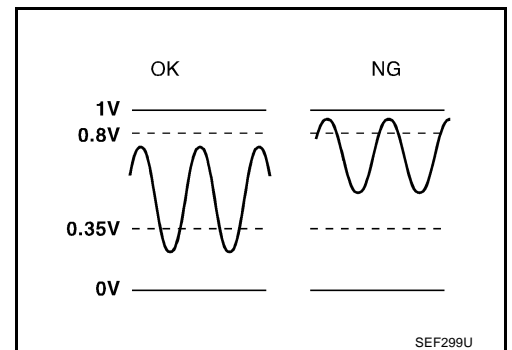

DTC No.	Trouble diagnosis name	DTC detecting condition	Possible cause
P1144 1144 (Bank 1)	Heated oxygen sensor 1 rich shift monitoring	The maximum and minimum voltages from the sensor are beyond the specified voltages.	<ul style="list-style-type: none"> ● Heated oxygen sensor 1 ● Heated oxygen sensor 1 heater ● Fuel pressure ● Injector
P1164 1164 (Bank 2)			

DTC Confirmation Procedure

CAUTION:

Always drive vehicle at a safe speed.

NOTE:

If DTC Confirmation Procedure has been previously conducted, always turn ignition switch OFF and wait at least 10 seconds before conducting the next test.

TESTING CONDITION:

- Always perform at a temperature above -10°C (14°F).
- Before performing the following procedure, confirm that battery voltage is more than 11V at idle.

WITH CONSULT-II

1. Start engine and warm it up to normal operating temperature.
2. Stop engine and wait at least 5 seconds.
3. Turn ignition switch ON and select "HO2S1 (B1) P1144" or "HO2S1 (B2) P1164" of "HO2S1" in "DTC WORK SUPPORT" mode with CONSULT-II.
4. Touch "START".
5. Start engine and let it idle for at least 3 minutes.

NOTE:

Never raise engine speed above 3,600 rpm after this step. If the engine speed limit is exceeded, return to step 5.

HO2S1 (B1) P1144	
OUT OF CONDITION	
MONITOR	
ENG SPEED	XXX rpm
B/FUEL SCHDL	XXX msec
COOLAN TEMP/S	XXX °C
VHCL SPEED SEN	XXX km/h

PBIB0548E

6. When the following conditions are met, "TESTING" will be displayed on the CONSULT-II screen. Maintain the conditions continuously until "TESTING" changes to "COMPLETED". (It will take approximately 40 seconds or more.)

ENG SPEED	1,000 - 3,100 rpm
Vehicle speed	Less than 100 km/h (62 MPH)
B/FUEL SCHDL	2.0 - 17.0 msec
Selector lever	Suitable position

HO2S1 (B1) P1144	
TESTING	
MONITOR	
ENG SPEED	XXX rpm
B/FUEL SCHDL	XXX msec
COOLAN TEMP/S	XXX °C
VHCL SPEED SEN	XXX km/h

PBIB0549E

If "TESTING" is not displayed after 5 minutes, retry from step 2.

7. Make sure that "OK" is displayed after touching "SELF-DIAG RESULTS". If "NG" is displayed, refer to [EC-441, "Diagnostic Procedure"](#).

HO2S1 (B1) P1144	
COMPLETED	

SEC772C

Overall Function Check

Use this procedure to check the overall function of the heated oxygen sensor 1 circuit. During this check, a DTC might not be confirmed.

WITH GST

1. Start engine and warm it up to normal operating temperature.
2. Set voltmeter probes between ECM terminal 35 [HO2S1(B1) signal] 16 [HO2S1(B2) signal] and ground.
3. Check one of the following with engine speed held at 2,000 rpm constant under no load.
 - The maximum voltage is below 0.8V at least 1 time.
 - The minimum voltage is below 0.35V at least 1 time.
4. If NG, go to [EC-441, "Diagnostic Procedure"](#) .

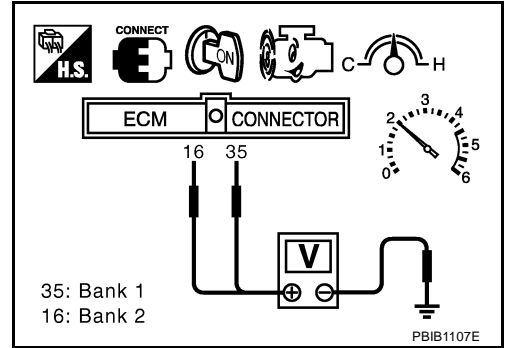

Diagnostic Procedure

1. CHECK GROUND CONNECTIONS

1. Turn ignition switch OFF.
2. Loosen and retighten ground three screws on the body. Refer to [EC-141, "Ground Inspection"](#) .

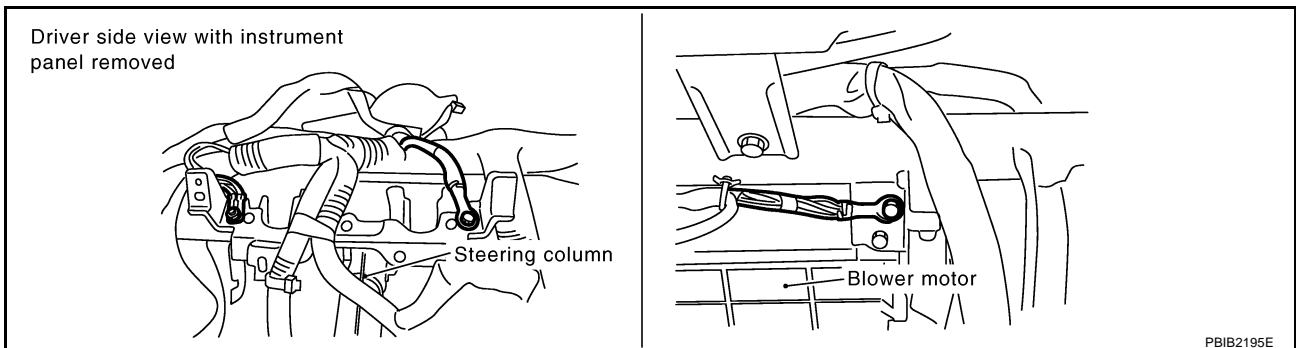

OK or NG

- OK >> GO TO 2.
- NG >> Repair or replace ground connections.

2. RETIGHTEN HEATED OXYGEN SENSOR 1

Loosen and retighten heated oxygen sensor 1.

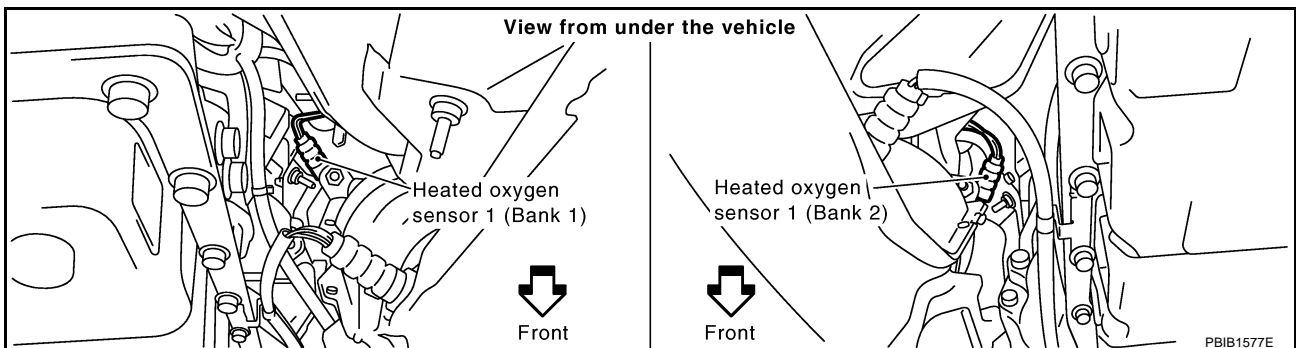

Tightening torque: 45 N-m (4.6 kg-m, 33 ft-lb)

>> GO TO 3.

3. CLEAR THE SELF-LEARNING DATA

④ With CONSULT-II

1. Start engine and warm it up to normal operating temperature.
2. Select "SELF-LEARNING CONT" in "WORK SUPPORT" mode with CONSULT-II.
3. Clear the self-learning control coefficient by touching "CLEAR".
4. Run engine for at least 10 minutes at idle speed.
Is the 1st trip DTC P0172 or P0175 detected?
Is it difficult to start engine?

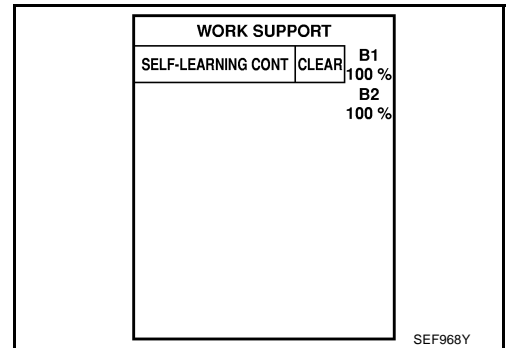

⊗ Without CONSULT-II

1. Start engine and warm it up to normal operating temperature.
2. Turn ignition switch OFF.
3. Disconnect mass air flow sensor harness connector, and restart and run engine for at least 5 seconds at idle speed.
4. Stop engine and reconnect mass air flow sensor harness connector.
5. Make sure DTC P0102 is displayed.
6. Erase the DTC memory. Refer to [EC-67, "HOW TO ERASE EMISSION-RELATED DIAGNOSTIC INFORMATION"](#).
7. Make sure DTC P0000 is displayed.
8. Run engine for at least 10 minutes at idle speed.
Is the 1st trip DTC P0172 or P0175 detected?
Is it difficult to start engine?

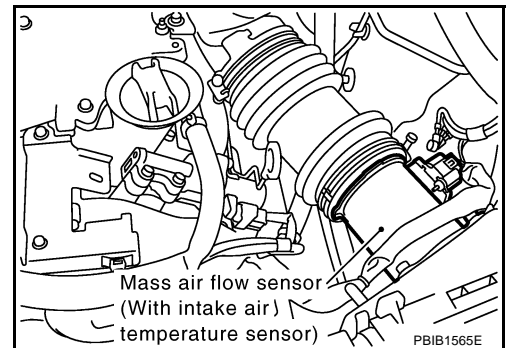

Yes or No

- Yes >> Perform trouble diagnosis for DTC P0172 or P0175. Refer to [EC-265](#).
- No >> GO TO 4.

4. CHECK HO2S1 CONNECTOR FOR WATER

1. Turn ignition switch OFF.
2. Disconnect heated oxygen sensor 1 harness connector.

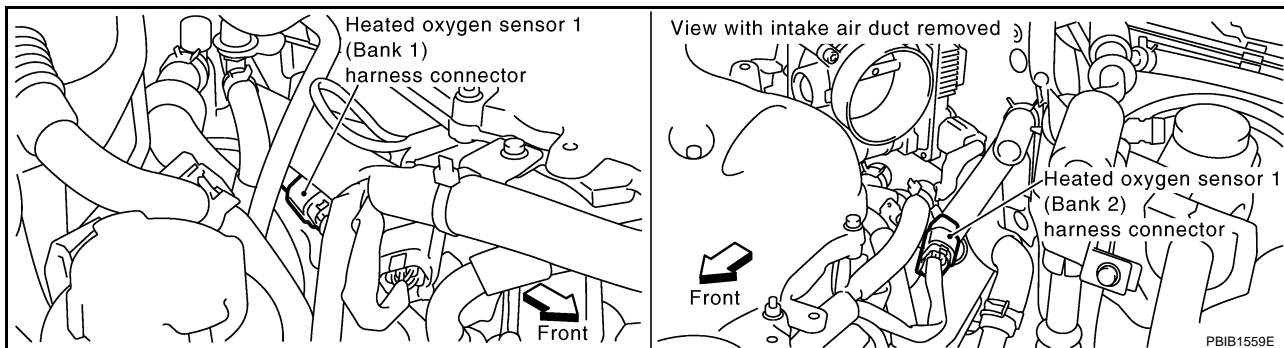

3. Check connectors for water.

Water should not exist.

OK or NG

- OK >> GO TO 5.
 NG >> Repair or replace harness or connectors.

5. CHECK HEATED OXYGEN SENSOR 1 HEATER

Refer to [EC-156, "Component Inspection"](#) .

OK or NG

- OK >> GO TO 6.
 NG >> Replace malfunctioning heated oxygen sensor 1.

6. CHECK HEATED OXYGEN SENSOR 1

Refer to [EC-443, "Component Inspection"](#) .

OK or NG

- OK >> GO TO 7.
 NG >> Replace malfunctioning heated oxygen sensor 1.

7. CHECK INTERMITTENT INCIDENT

Refer to [EC-135, "TROUBLE DIAGNOSIS FOR INTERMITTENT INCIDENT"](#) .
 For circuit, refer to [EC-207, "Wiring Diagram"](#) .

>> INSPECTION END

Component Inspection HEATED OXYGEN SENSOR 1

ABS006UC

Ⓟ **With CONSULT-II**

1. Start engine and warm it up to normal operating temperature.
2. Select "MANU TRIG" and adjust "TRIGGER POINT" to 100% in "DATA MONITOR" mode with CONSULT-II.
3. Select "HO2S1 (B1)" and "HO2S1 MNTR (B1)".
4. Hold engine speed at 2,000 rpm under no load during the following steps.

5. Touch "RECORD" on CONSULT-II screen.

DATA MONITOR	
MONITOR	NO DTC
ENG SPEED	XXX rpm
MAS A/F SE-B1	XXX V
COOLAN TEMP/S	XXX °C
HO2S1 (B1)	XXX V
HO2S1 MNTR (B1)	LEAN

SEF646Y

6. Check the following.

- "HO2S1 MNTR (B1)/(B2)" in "DATA MONITOR" mode changes from "RICH" to "LEAN" to "RICH" 5 times in 10 seconds.
5 times (cycles) are counted as shown at right.
- "HO2S1 (B1)/(B2)" voltage goes above 0.6V at least once.
- "HO2S1 (B1)/(B2)" voltage goes below 0.3V at least once.
- "HO2S1 (B1)/(B2)" voltage never exceeds 1.0V.

Bank 1	cycle	1	2	3	4	5
	HO2S1 MNTR (B1)	R	L	R	L	R
Bank 2	cycle	1	2	3	4	5
	HO2S1 MNTR (B2)	R	L	R	L	R

R means HO2S1
MNTR (B1)/(B2) indicates RICH
L means HO2S1
MNTR (B1)/(B2) indicates LEAN

SEF647Y

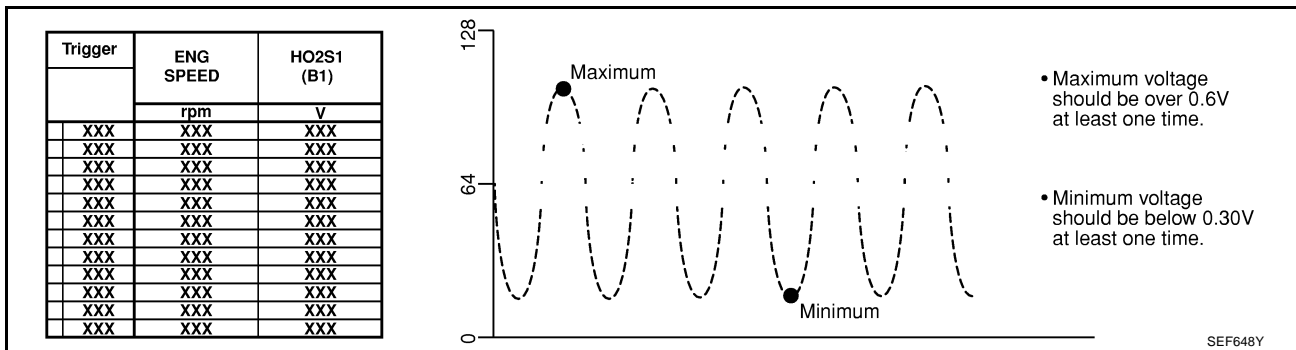

CAUTION:

- Discard any heated oxygen sensor which has been dropped from a height of more than 0.5 m (19.7 in) onto a hard surface such as a concrete floor; use a new one.
- Before installing new oxygen sensor, clean exhaust system threads using Oxygen Sensor Thread Cleaner tool J-43897-18 or J-43897-12 and approved anti-seize lubricant.

Without CONSULT-II

1. Start engine and warm it up to normal operating temperature.
 2. Set voltmeter probes between ECM terminal 35 [HO2S1 (B1) signal] or 16 [HO2S1 (B2) signal] and ground.
 3. Check the following with engine speed held at 2,000 rpm constant under no load.
 - The voltage fluctuates between 0 to 0.3V and 0.6 to 1.0V more than 5 times within 10 seconds.
 - The maximum voltage is over 0.6V at least one time.
 - The minimum voltage is below 0.3V at least one time.
 - The voltage never exceeds 1.0V.
- 1 time: 0 - 0.3V → 0.6 - 1.0V → 0 - 0.3V
 2 times: 0 - 0.3V → 0.6 - 1.0V → 0 - 0.3V → 0.6 - 1.0V

CAUTION:

- Discard any heated oxygen sensor which has been dropped from a height of more than 0.5 m (19.7 in) onto a hard surface such as a concrete floor; use a new one.

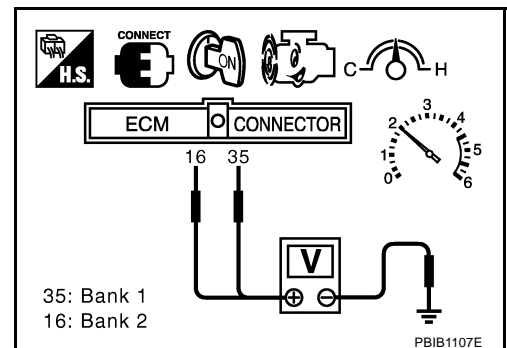

- Before installing new oxygen sensor, clean exhaust system threads using Oxygen Sensor Thread Cleaner tool J-43897-18 or J-43897-12 and approved anti-seize lubricant.

A

Removal and Installation
HEATED OXYGEN SENSOR 1

ABS006UD

Refer to [EM-26, "EXHAUST MANIFOLD AND THREE WAY CATALYST"](#) .

EC

C

D

E

F

G

H

I

J

K

L

M

DTC P1146, P1166 HO2S2

PFP:226A0

Component Description

ABS006UE

The heated oxygen sensor 2, after three way catalyst 1, monitors the oxygen level in the exhaust gas on each bank.

Even if switching characteristics of the heated oxygen sensor 1 are shifted, the air-fuel ratio is controlled to stoichiometric, by the signal from the heated oxygen sensor 2.

This sensor is made of ceramic zirconia. The zirconia generates voltage from approximately 1V in richer conditions to 0V in leaner conditions.

Under normal conditions the heated oxygen sensor 2 is not used for engine control operation.

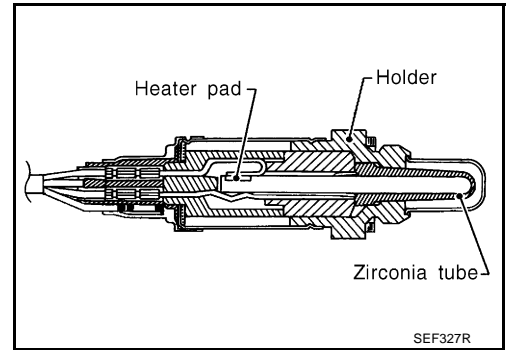

CONSULT-II Reference Value in Data Monitor Mode

ABS006UF

Specification data are reference values.

MONITOR ITEM	CONDITION		SPECIFICATION
HO2S2 (B1) HO2S2 (B2)	<ul style="list-style-type: none"> ● Warm-up condition ● After keeping engine speed between 3,500 and 4,000 rpm for 1 minute and at idle for 1 minute under no load. 	Revsing engine from idle to 3,000 rpm quickly.	0 - 0.3V ↔ Approx. 0.6 - 1.0V
HO2S2 MNTR (B1) HO2S2 MNTR (B2)			LEAN ↔ RICH

On Board Diagnosis Logic

ABS006UG

The heated oxygen sensor 2 has a much longer switching time between rich and lean than the heated oxygen sensor 1. The oxygen storage capacity of the three way catalyst 1 causes the longer switching time. To judge the malfunctions of heated oxygen sensor 2, ECM monitors whether the minimum voltage of sensor is sufficiently low during the various driving condition such as fuel-cut.

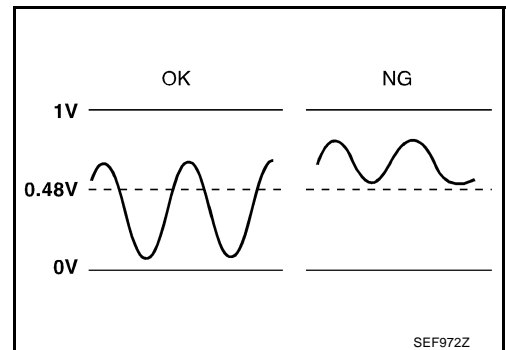

DTC No.	Trouble diagnosis name	DTC detecting condition	Possible cause
P1146 1146 (Bank 1)	Heated oxygen sensor 2 minimum voltage monitoring	The minimum voltage from the sensor is not reached to the specified voltage.	<ul style="list-style-type: none"> ● Harness or connectors (The sensor circuit is open or shorted) ● Heated oxygen sensor 2 ● Fuel pressure ● Fuel injector
P1166 1166 (Bank 2)			

DTC Confirmation Procedure

ABS006UH

NOTE:

If DTC confirmation Procedure has been previously conducted, always turn ignition switch OFF and wait at least 10 seconds before conducting the next test.

Ⓟ WITH CONSULT-II

TESTING CONDITION:

For better results, perform DTC WORK SUPPORT at a temperature of 0 to 30 °C (32 to 86 °F).

1. Turn ignition switch ON and select "DATA MONITOR" mode with CONSULT-II.
2. Start engine and warm it up to the normal operating temperature.
3. Turn ignition switch OFF and wait at least 10 seconds.
4. Start engine and keep the engine speed between 3,500 and 4,000 rpm for at least 1 minute under no load.
5. Let engine idle for 1 minute.
6. Make sure that "COOLAN TEMP/S" indicates more than 70°C (158°F).
If not, warm up engine and go to next step when "COOLAN TEMP/S" indication reaches to 70°C (158°F).
7. Open engine hood.
8. Select "HO2S2 (B1) P1146" or "HO2S2 (B2) P1166" of "HO2S2" in "DTC WORK SUPPORT" mode with CONSULT-II.
9. Start engine and following the instruction of CONSULT-II.

DATA MONITOR	
MONITOR	NO DTC
ENG SPEED	XXX rpm
COOLAN TEMP/S	XXX °C

SEF174Y

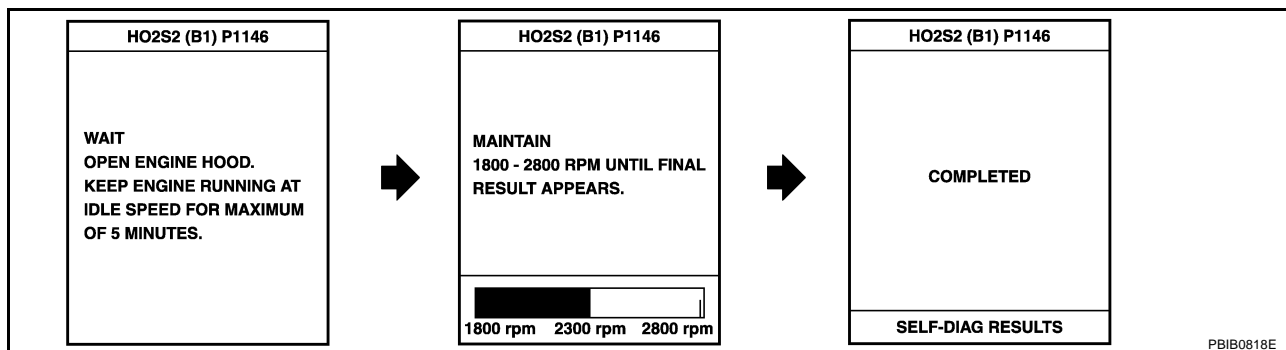

10. Make sure that "OK" is displayed after touching "SELF-DIAG RESULTS".
If "NG" is displayed, refer to [EC-452, "Diagnostic Procedure"](#).
If "CAN NOT BE DIAGNOSED" is displayed, perform the following.
 - a. Turn ignition switch OFF and leave the vehicle in a cool place (soak the vehicle).
 - b. Return to step 1.

Overall Function Check

ABS006UI

Use this procedure to check the overall function of the heated oxygen sensor 2 circuit. During this check, a 1st trip DTC might not be confirmed.

Ⓟ WITH GST

1. Start engine and warm it up to the normal operating temperature.
2. Turn ignition switch OFF and wait at least 10 seconds.
3. Start engine and keep the engine speed between 3,500 and 4,000 rpm for at least 1 minute under no load.
4. Let engine idle for 1 minute.
5. Set voltmeter probes between ECM terminal 74 [HO2S2 (B1) signal] or 55 [HO2S2 (B2) signal] and ground.

6. Check the voltage when revving up to 4,000 rpm under no load at least 10 times.
(Depress and release accelerator pedal as soon as possible.)
The voltage should be below 0.48V at least once during this procedure.
If the voltage can be confirmed in step 6, step 7 is not necessary.
7. Keep vehicle at idling for 10 minutes, then check the voltage. Or check the voltage when coasting from 80 km/h (50 MPH) in D position with "OD" OFF.
The voltage should be below 0.48V at least once during this procedure.
8. If NG, go to [EC-452, "Diagnostic Procedure"](#).

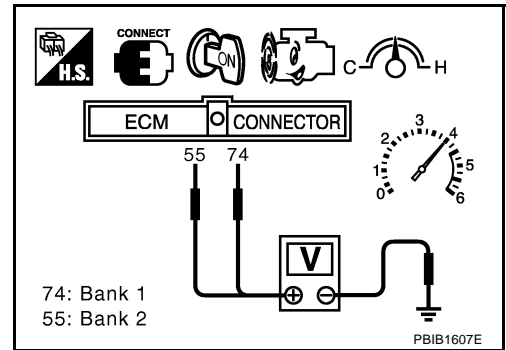

Wiring Diagram
BANK 1

EC-O2S2B1-01

— : DETECTABLE LINE FOR DTC
— : NON-DETECTABLE LINE FOR DTC

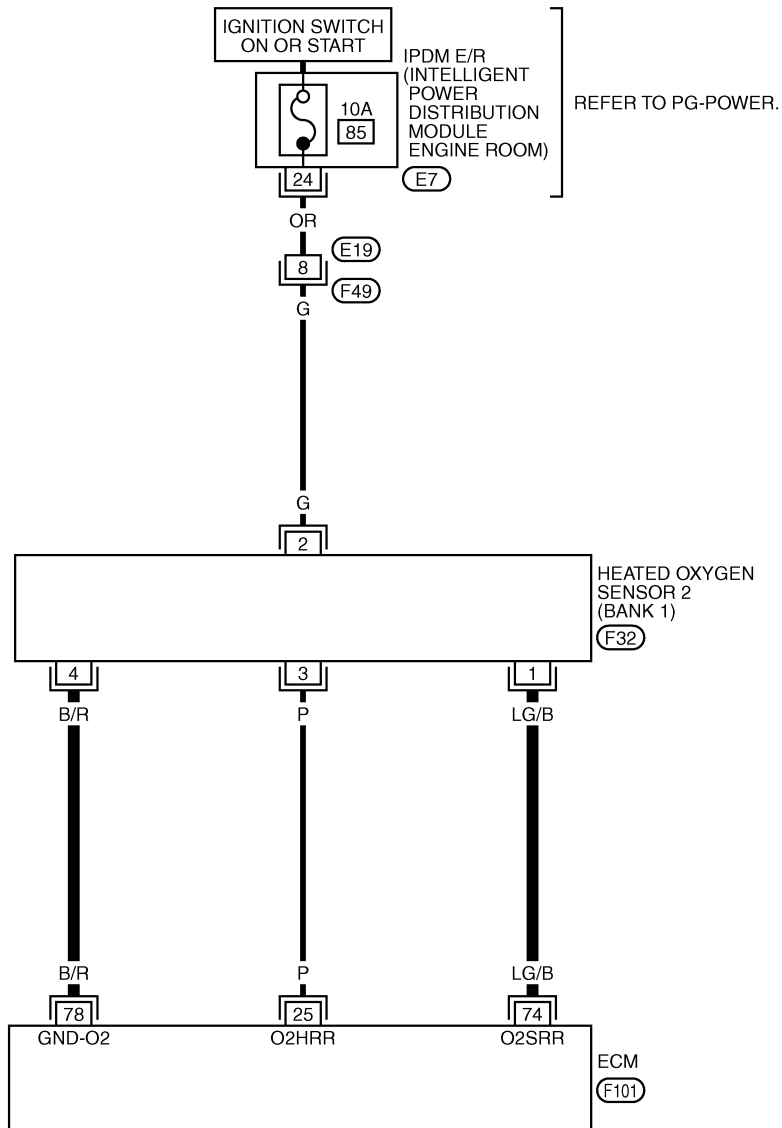

23	22	21	20	19	18	17		
32	31	30	29	28	27	26	25	24

E7
GY



F32
B



F49
B

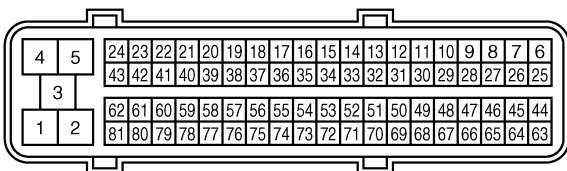

F101
B



DTC P1146, P1166 HO2S2

[VQ35DE]

Specification data are reference values and are measured between each terminal and ground.

CAUTION:

Do not use ECM ground terminals when measuring input/output voltage. Doing so may result in damage to the ECM's transistor. Use a ground other than ECM terminals, such as the ground.

TER-MINAL NO.	WIRE COLOR	ITEM	CONDITION	DATA (DC Voltage)
74	LG/B	Heated oxygen sensor 2 (bank 1)	[Engine is running] <ul style="list-style-type: none">● Warm-up condition● Revving engine from idle to 3,000 rpm quickly after the following conditions are met<ul style="list-style-type: none">– After keeping the engine speed between 3,500 and 4,000 rpm for 1 minute and at idle for 1 minute under no load	0 - Approximately 1.0V
78	B/R	Sensor ground (Heated oxygen sensor)	[Engine is running] <ul style="list-style-type: none">● Warm-up condition● Idle speed	Approximately 0V

BANK 2

EC-O2S2B2-01

— : DETECTABLE LINE FOR DTC
 — : NON-DETECTABLE LINE FOR DTC

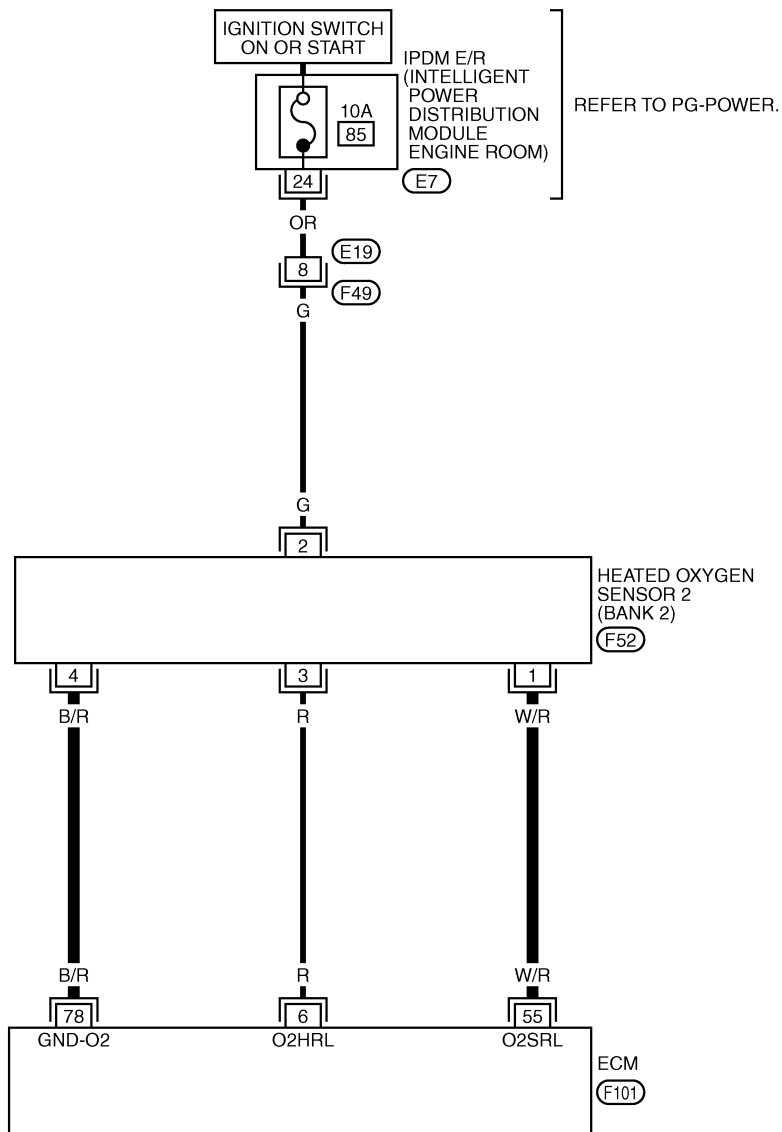

23	22	21	20	19	18	17		
32	31	30	29	28	27	26	25	24

(E7) GY

1	2	3	4
5	6	7	8

(F49) B

3	1
4	2

(F52) GY

4	5	24	23	22	21	20	19	18	17	16	15	14	13	12	11	10	9	8	7	6
3		43	42	41	40	39	38	37	36	35	34	33	32	31	30	29	28	27	26	25
		62	61	60	59	58	57	56	55	54	53	52	51	50	49	48	47	46	45	44
1	2	81	80	79	78	77	76	75	74	73	72	71	70	69	68	67	66	65	64	63

(F101) B

Specification data are reference values and are measured between each terminal and ground.

CAUTION:

Do not use ECM ground terminals when measuring input/output voltage. Doing so may result in damage to the ECM's transistor. Use a ground other than ECM terminals, such as the ground.

TER-MINAL NO.	WIRE COLOR	ITEM	CONDITION	DATA (DC Voltage)
55	W/R	Heated oxygen sensor 2 (bank 2)	<p>[Engine is running]</p> <ul style="list-style-type: none"> ● Warm-up condition ● Revving engine from idle to 3,000 rpm quickly after the following conditions are met <ul style="list-style-type: none"> - After keeping the engine speed between 3,500 and 4,000 rpm for 1 minute and at idle for 1 minute under no load 	0 - Approximately 1.0V
78	B/R	Sensor ground (Heated oxygen sensor)	<p>[Engine is running]</p> <ul style="list-style-type: none"> ● Warm-up condition ● Idle speed 	Approximately 0V

Diagnostic Procedure

ABS006UK

1. CHECK GROUND CONNECTIONS

1. Turn ignition switch OFF.
2. Loosen and retighten ground three screws on the body. Refer to [EC-141, "Ground Inspection"](#).

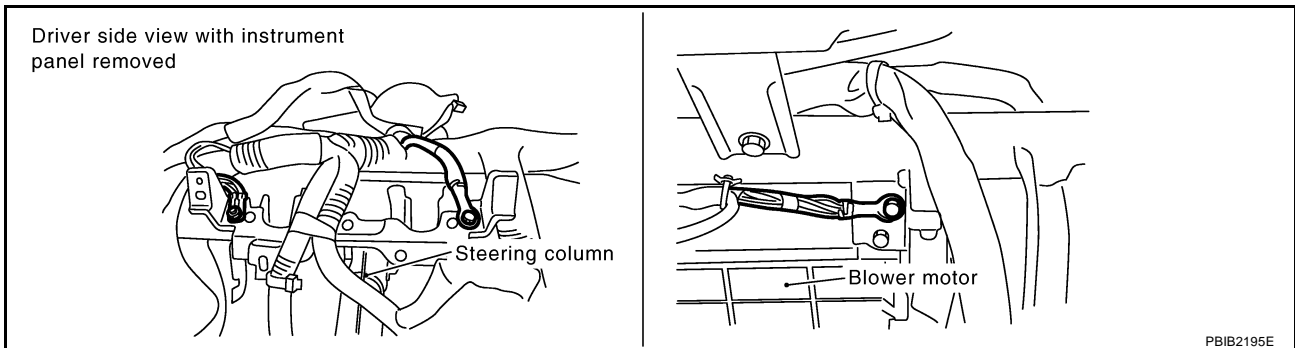

OK or NG

- OK >> GO TO 2.
- NG >> Repair or replace ground connections.

2. CLEAR THE SELF-LEARNING DATA

☐ With CONSULT-II

1. Start engine and warm it up to normal operating temperature.
2. Select "SELF-LEARNING CONT" in "WORK SUPPORT" mode with CONSULT-II.
3. Clear the self-learning control coefficient by touching "CLEAR".
4. Run engine for at least 10 minutes at idle speed.
Is the 1st trip DTC P0172 or P0175 detected?
Is it difficult to start engine?

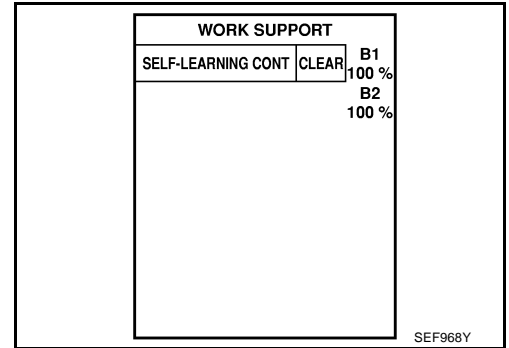

⊗ Without CONSULT-II

1. Start engine and warm it up to normal operating temperature.
2. Turn ignition switch OFF.
3. Disconnect mass air flow sensor harness connector, and restart and run engine for at least 5 seconds at idle speed.
4. Stop engine and reconnect mass air flow sensor harness connector.
5. Make sure DTC P0102 is displayed.
6. Erase the DTC memory. Refer to [EC-67, "HOW TO ERASE EMISSION-RELATED DIAGNOSTIC INFORMATION"](#).
7. Make sure DTC P0000 is displayed.
8. Run engine for at least 10 minutes at idle speed.
Is the 1st trip DTC P0172 or P0175 detected?
Is it difficult to start engine?

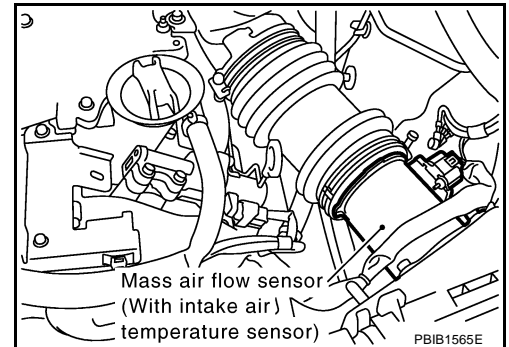

Yes or No

- Yes >> Perform trouble diagnosis for DTC P0172, P0175. Refer to [EC-265](#).
- No >> GO TO 3.

3. CHECK HO2S2 GROUND CIRCUIT FOR OPEN AND SHORT

1. Turn ignition switch OFF.
2. Disconnect heated oxygen sensor 2 harness connector.
3. Disconnect ECM harness connector.
4. Check harness continuity between HO2S2 terminal 4 and ECM terminal 78.
Refer to Wiring Diagram.

Continuity should exist.

5. Also check harness for short to ground and short to power.

OK or NG

- OK >> GO TO 4.
- NG >> Repair open circuit or short to ground or short to power in harness or connectors.

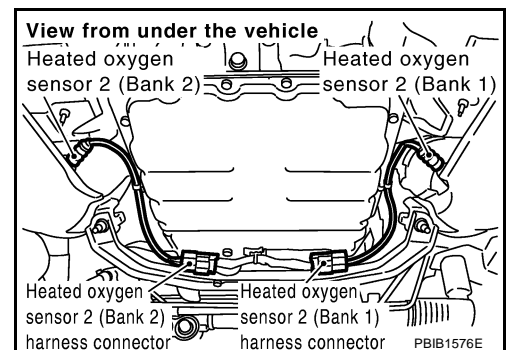

4. CHECK HO2S2 INPUT SIGNAL CIRCUIT FOR OPEN AND SHORT

1. Check harness continuity between ECM terminal and HO2S2 terminal as follows.
Refer to Wiring Diagram.

DTC	Terminals		Bank
	ECM	Sensor	
P1146	74	1	1
P1166	55	1	2

Continuity should exist.

2. Check harness continuity between the following terminals and ground.
Refer to Wiring Diagram.

DTC	Terminals		Bank
	ECM	Sensor	
P1146	74	1	1
P1166	55	1	2

Continuity should not exist.

3. Also check harness for short to power.

OK or NG

OK >> GO TO 5.

NG >> Repair open circuit or short to ground or short to power in harness or connectors.

5. CHECK HEATED OXYGEN SENSOR 2

Refer to [EC-454, "Component Inspection"](#) .

OK or NG

OK >> GO TO 6.

NG >> Replace malfunctioning heated oxygen sensor 2.

6. CHECK INTERMITTENT INCIDENT

Refer to [EC-135, "TROUBLE DIAGNOSIS FOR INTERMITTENT INCIDENT"](#) .

>> INSPECTION END

Component Inspection HEATED OXYGEN SENSOR 2

ABS006UL

Ⓟ With CONSULT-II

1. Turn ignition switch ON and select "DATA MONITOR" mode with CONSULT-II.
2. Start engine and warm it up to the normal operating temperature.
3. Turn ignition switch OFF and wait at least 10 seconds.
4. Start engine and keep the engine speed between 3,500 and 4,000 rpm for at least 1 minute under no load.
5. Let engine idle for 1 minute.

DATA MONITOR	
MONITOR	NO DTC
ENG SPEED	XXX rpm
COOLANT TEMP/S	XXX °C

SEF174Y

- Select "FUEL INJECTION" in "ACTIVE TEST" mode, and select "HO2S2 (B1)/(B2)" as the monitor item with CONSULT-II.

ACTIVE TEST	
FUEL INJECTION	25 %
MONITOR	
ENG SPEED	XXX rpm
HO2S1 (B1)	XXX V
HO2S2 (B1)	XXX V
HO2S1 MNTR (B1)	RICH
HO2S2 MNTR (B1)	RICH

SEF662Y

- Check "HO2S2 (B1)/(B2)" at idle speed when adjusting "FUEL INJECTION" to $\pm 25\%$.

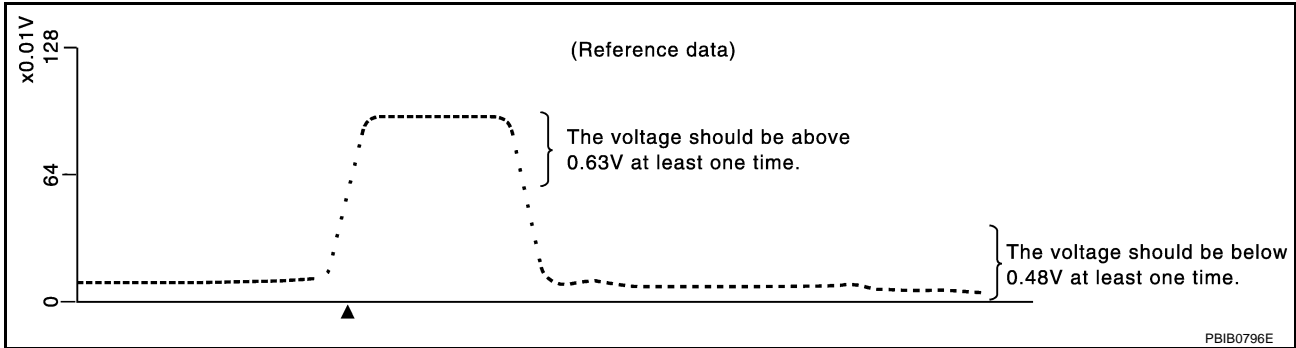

"HO2S2 (B1)/(B2)" should be above 0.63V at least once when the "FUEL INJECTION" is +25%.
 "HO2S2 (B1)/(B2)" should be below 0.48V at least once when the "FUEL INJECTION" is -25%.

CAUTION:

- Discard any heated oxygen sensor which has been dropped from a height of more than 0.5 m (19.7 in) onto a hard surface such as a concrete floor; use a new one.
- Before installing new oxygen sensor, clean exhaust system threads using Oxygen Sensor Thread Cleaner tool J-43897-18 or J-43897-12 and approved anti-seize lubricant.

Without CONSULT-II

- Start engine and warm it up to the normal operating temperature.
- Turn ignition switch OFF and wait at least 10 seconds.
- Start engine and keep the engine speed between 3,500 and 4,000 rpm for at least 1 minute under no load.
- Let engine idle for 1 minute.
- Set voltmeter probes between ECM terminal 74 [HO2S2 (B1) signal] or 55 [HO2S2 (B2) signal] and ground.
- Check the voltage when revving up to 4,000 rpm under no load at least 10 times.
 (Depress and release accelerator pedal as soon as possible.)
The voltage should be above 0.63V at least once during this procedure.
If the voltage is above 0.63V at step 6, step 7 is not necessary.
- Keep vehicle at idling for 10 minutes, then check voltage. Or check the voltage when coasting from 80 km/h (50 MPH) in D position with "OD" OFF.
The voltage should be below 0.48V at least once during this procedure.
- If NG, replace heated oxygen sensor 2.

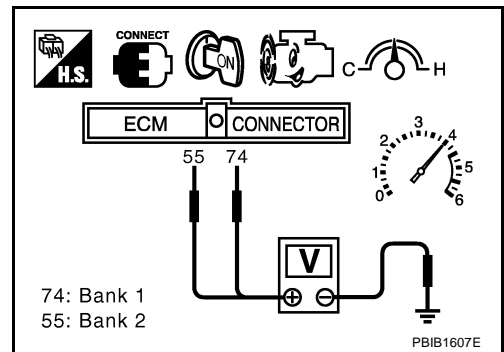

CAUTION:

- Discard any heated oxygen sensor which has been dropped from a height of more than 0.5 m (19.7 in) onto a hard surface such as a concrete floor; use a new one.
- Before installing new oxygen sensor, clean exhaust system threads using Oxygen Sensor Thread Cleaner tool J-43897-18 or J-43897-12 and approved anti-seize lubricant.

Removal and Installation
HEATED OXYGEN SENSOR 2

ABS006UM

Refer to [EM-26, "EXHAUST MANIFOLD AND THREE WAY CATALYST"](#) .

DTC P1147, P1167 HO2S2

PF2:226A0

Component Description

ABS006UN

The heated oxygen sensor 2, after three way catalyst 1, monitors the oxygen level in the exhaust gas on each bank.

Even if switching characteristics of the heated oxygen sensor 1 are shifted, the air-fuel ratio is controlled to stoichiometric, by the signal from the heated oxygen sensor 2.

This sensor is made of ceramic zirconia. The zirconia generates voltage from approximately 1V in richer conditions to 0V in leaner conditions.

Under normal conditions the heated oxygen sensor 2 is not used for engine control operation.

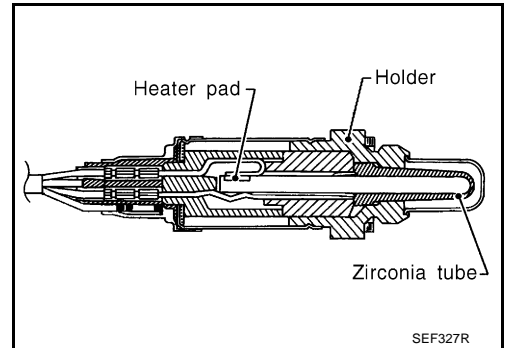

CONSULT-II Reference Value in Data Monitor Mode

ABS006UO

Specification data are reference values.

MONITOR ITEM	CONDITION		SPECIFICATION
HO2S2 (B1) HO2S2 (B2)	<ul style="list-style-type: none"> ● Warm-up condition ● After keeping engine speed between 3,500 and 4,000 rpm for 1 minute and at idle for 1 minute under no load. 	Revving engine from idle to 3,000 rpm quickly.	0 - 0.3V ↔ Approx. 0.6 - 1.0V
HO2S2 MNTR (B1) HO2S2 MNTR (B2)			LEAN ↔ RICH

On Board Diagnosis Logic

ABS006UP

The heated oxygen sensor 2 has a much longer switching time between rich and lean than the heated oxygen sensor 1. The oxygen storage capacity of the three way catalyst 1 causes the longer switching time. To judge the malfunctions of heated oxygen sensor 2, ECM monitors whether the maximum voltage of the sensor is sufficiently high during the various driving condition such as fuel-cut.

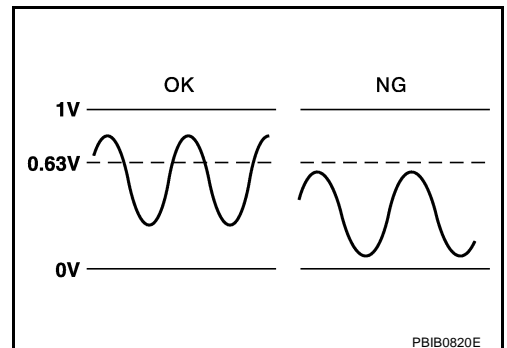

DTC No.	Trouble diagnosis name	DTC detecting condition	Possible cause
P1147 1147 (Bank 1)	Heated oxygen sensor 2 maximum voltage monitoring	The maximum voltage from the sensor is not reached to the specified voltage.	<ul style="list-style-type: none"> ● Harness or connectors (The sensor circuit is open or shorted) ● Heated oxygen sensor 2 ● Fuel pressure ● Fuel injector ● Intake air leaks
P1167 1167 (Bank 2)			

DTC Confirmation Procedure

NOTE:

If DTC confirmation Procedure has been previously conducted, always turn ignition switch OFF and wait at least 10 seconds before conducting the next test.

WITH CONSULT-II

TESTING CONDITION:

For better results, perform DTC WORK SUPPORT at a temperature of 0 to 30 °C (32 to 86 °F).

1. Turn ignition switch ON and select "DATA MONITOR" mode with CONSULT-II.
2. Start engine and warm it up to the normal operating temperature.
3. Turn ignition switch OFF and wait at least 10 seconds.
4. Start engine and keep the engine speed between 3,500 and 4,000 rpm for at least 1 minute under no load.
5. Let engine idle for 1 minute.
6. Make sure that "COOLAN TEMP/S" indicates more than 70°C (158°F).
If not, warm up engine and go to next step when "COOLAN TEMP/S" indication reaches to 70°C (158°F).
7. Open engine hood.
8. Select "HO2S2 (B1) P1147" or "HO2S2 (B2) P1167" of "HO2S2" in "DTC WORK SUPPORT" mode with CONSULT-II.
9. Start engine and following the instruction of CONSULT-II.

DATA MONITOR	
MONITOR	NO DTC
ENG SPEED	XXX rpm
COOLAN TEMP/S	XXX °C

SEF174Y

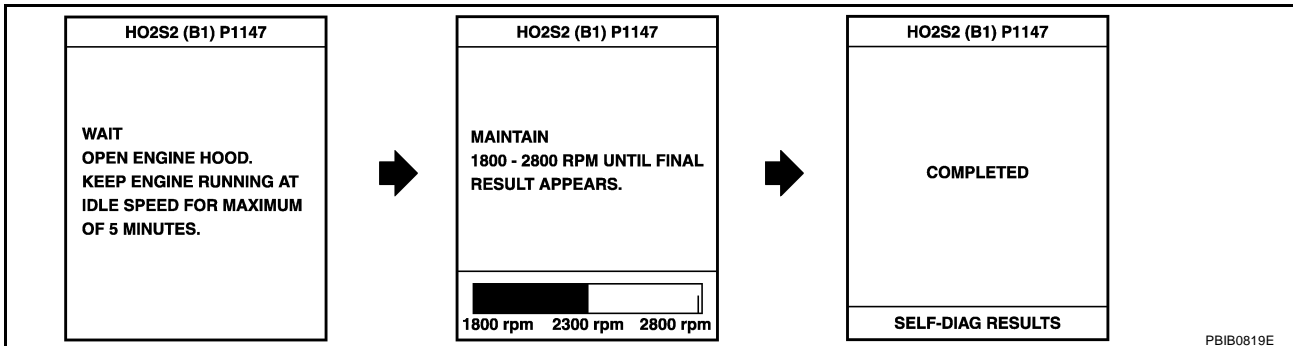

10. Make sure that "OK" is displayed after touching "SELF-DIAG RESULTS".
If "NG" is displayed, refer to [EC-463, "Diagnostic Procedure"](#).
If "CAN NOT BE DIAGNOSED" is displayed, perform the following.
 - a. Turn ignition switch OFF and leave the vehicle in a cool place (soak the vehicle).
 - b. Return to step 1.

Overall Function Check

Use this procedure to check the overall function of the heated oxygen sensor 2 circuit. During this check, a 1st trip DTC might not be confirmed.

WITH GST

1. Start engine and warm it up to the normal operating temperature.
2. Turn ignition switch OFF and wait at least 10 seconds.
3. Start engine and keep the engine speed between 3,500 and 4,000 rpm for at least 1 minute under no load.
4. Let engine idle for 1 minute.
5. Set voltmeter probes between ECM terminal 74 [HO2S2 (B1) signal] or 55 [HO2S2 (B2) signal] and ground.

DTC P1147, P1167 HO2S2

[VQ35DE]

6. Check the voltage when revving up to 4,000 rpm under no load at least 10 times.
(Depress and release accelerator pedal as soon as possible.)
The voltage should be above 0.63V at least once during this procedure.
If the voltage can be confirmed in step 6, step 7 is not necessary.
7. Keep vehicle at idling for 10 minutes, then check the voltage. Or check the voltage when coasting from 80 km/h (50 MPH) in D position with "OD" OFF.
The voltage should be above 0.63V at least once during this procedure.
8. If NG, go to [EC-463, "Diagnostic Procedure"](#) .

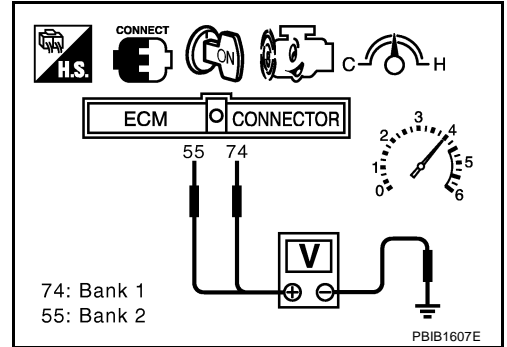

A
EC
C
D
E
F
G
H
I
J
K
L
M

Wiring Diagram
BANK 1

EC-O2S2B1-01

— : DETECTABLE LINE FOR DTC
 — : NON-DETECTABLE LINE FOR DTC

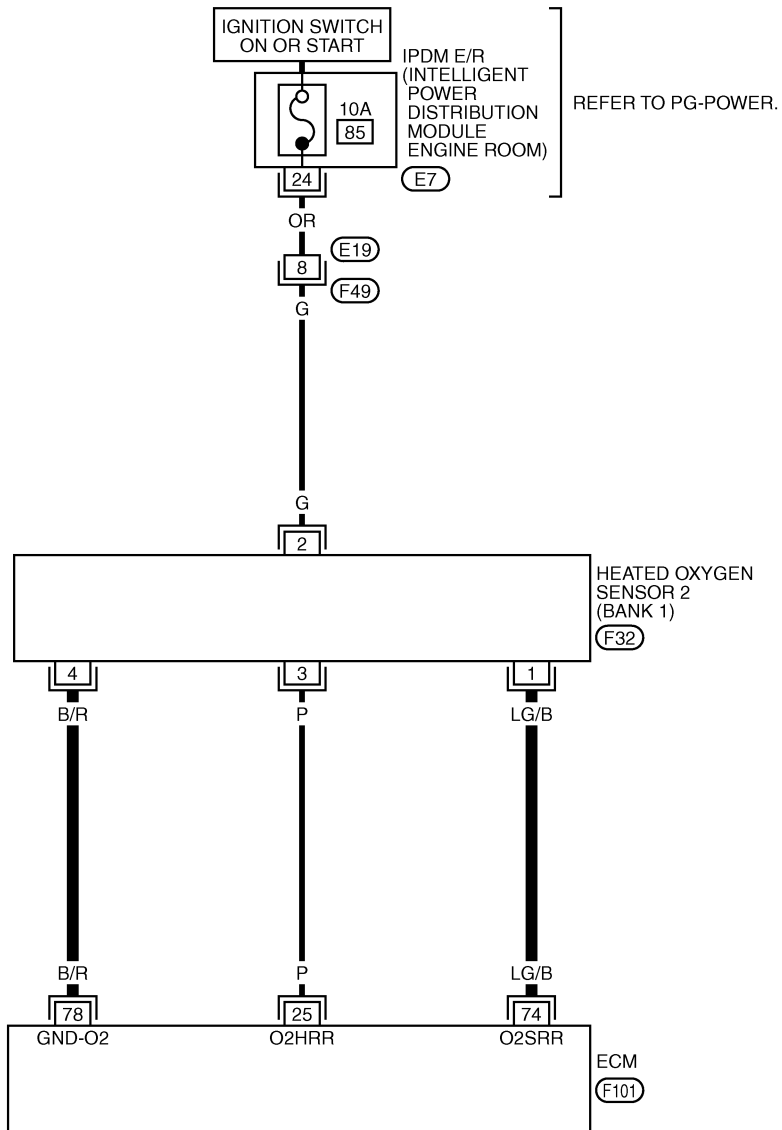

23	22	21	20	19	18	17		
32	31	30	29	28	27	26	25	24

E7
GY



F32
B



F49
B

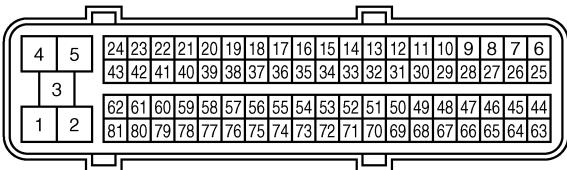

F101
B



DTC P1147, P1167 HO2S2

[VQ35DE]

Specification data are reference values and are measured between each terminal and ground.

CAUTION:

Do not use ECM ground terminals when measuring input/output voltage. Doing so may result in damage to the ECM's transistor. Use a ground other than ECM terminals, such as the ground.

TER-MINAL NO.	WIRE COLOR	ITEM	CONDITION	DATA (DC Voltage)
74	LG/B	Heated oxygen sensor 2 (bank 1)	<p>[Engine is running]</p> <ul style="list-style-type: none"> ● Warm-up condition ● Revving engine from idle to 3,000 rpm quickly after the following conditions are met – After keeping the engine speed between 3,500 and 4,000 rpm for 1 minute and at idle for 1 minute under no load 	0 - Approximately 1.0V
78	B/R	Sensor ground (Heated oxygen sensor)	<p>[Engine is running]</p> <ul style="list-style-type: none"> ● Warm-up condition ● Idle speed 	Approximately 0V

A
EC
C
D
E
F
G
H
I
J
K
L
M

BANK 2

EC-O2S2B2-01

— : DETECTABLE LINE FOR DTC
 — : NON-DETECTABLE LINE FOR DTC

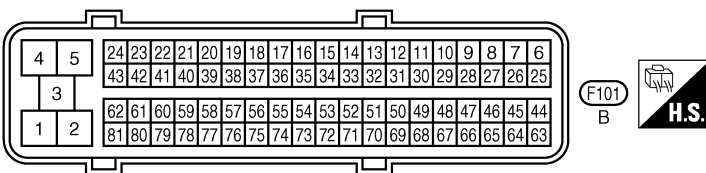
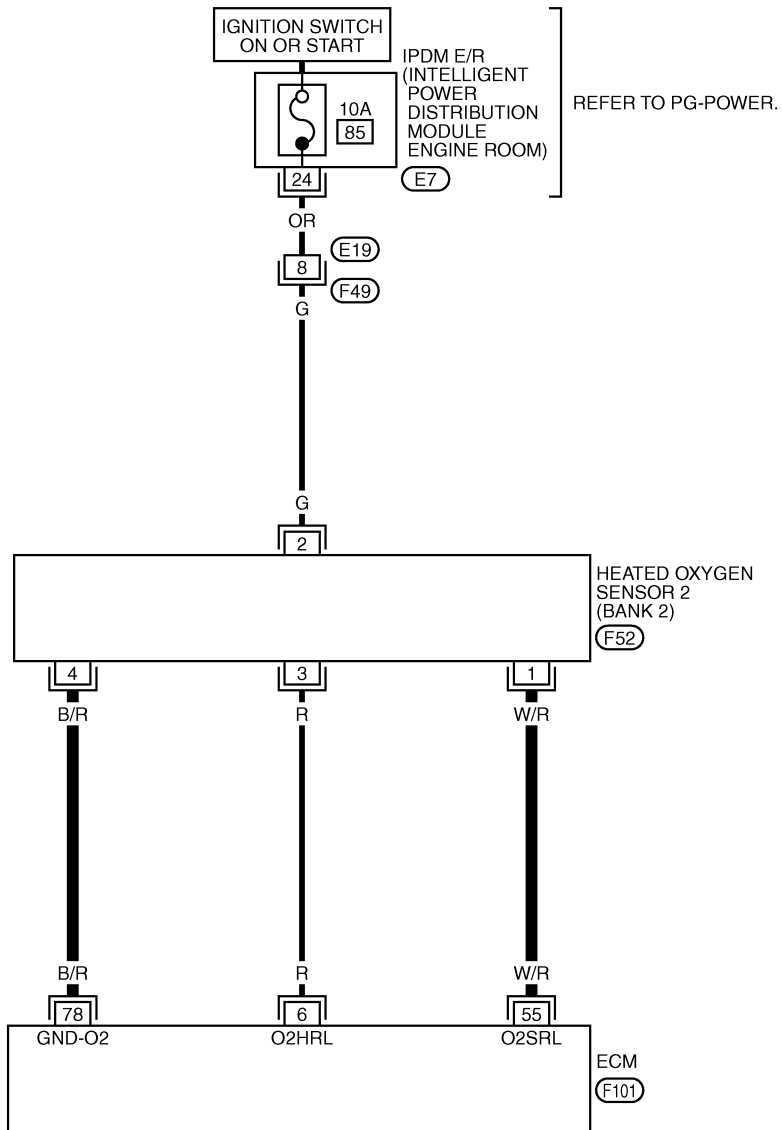

Specification data are reference values and are measured between each terminal and ground.

CAUTION:

Do not use ECM ground terminals when measuring input/output voltage. Doing so may result in damage to the ECM's transistor. Use a ground other than ECM terminals, such as the ground.

TER-MINAL NO.	WIRE COLOR	ITEM	CONDITION	DATA (DC Voltage)
55	W/R	Heated oxygen sensor 2 (bank 2)	<p>[Engine is running]</p> <ul style="list-style-type: none"> ● Warm-up condition ● Revving engine from idle to 3,000 rpm quickly after the following conditions are met – After keeping the engine speed between 3,500 and 4,000 rpm for 1 minute and at idle for 1 minute under no load 	0 - Approximately 1.0V
78	B/R	Sensor ground (Heated oxygen sensor)	<p>[Engine is running]</p> <ul style="list-style-type: none"> ● Warm-up condition ● Idle speed 	Approximately 0V

Diagnostic Procedure

ABS00CHO

1. CHECK GROUND CONNECTIONS

1. Turn ignition switch OFF.
2. Loosen and retighten ground three screws on the body. Refer to [EC-141, "Ground Inspection"](#).

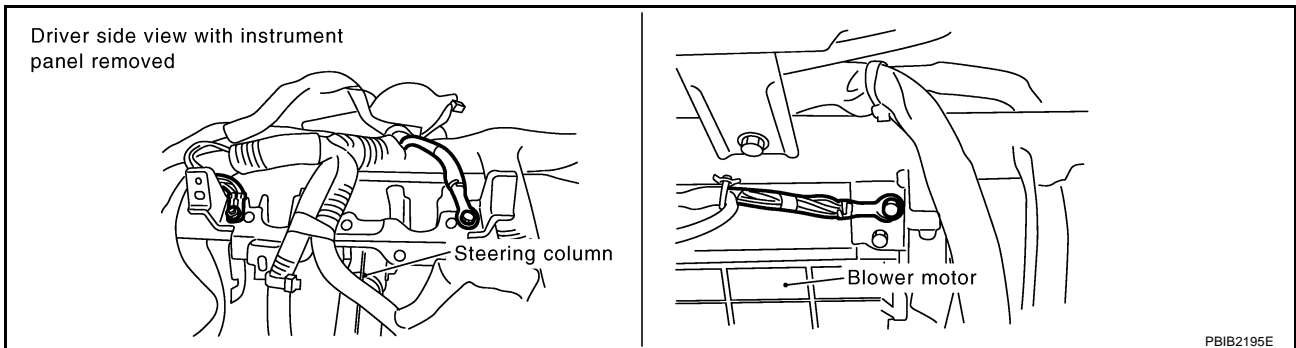

OK or NG

- OK >> GO TO 2.
- NG >> Repair or replace ground connections.

2. CLEAR THE SELF-LEARNING DATA

☐ With CONSULT-II

1. Start engine and warm it up to normal operating temperature.
2. Select "SELF-LEARNING CONT" in "WORK SUPPORT" mode with CONSULT-II.
3. Clear the self-learning control coefficient by touching "CLEAR".
4. Run engine for at least 10 minutes at idle speed.
**Is the 1st trip DTC P0171 or P0174 detected?
Is it difficult to start engine?**

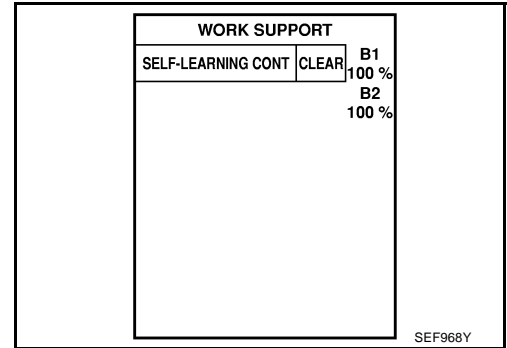

⊗ Without CONSULT-II

1. Start engine and warm it up to normal operating temperature.
2. Turn ignition switch OFF.
3. Disconnect mass air flow sensor harness connector, and restart and run engine for at least 5 seconds at idle speed.
4. Stop engine and reconnect mass air flow sensor harness connector.
5. Make sure DTC P0102 is displayed.
6. Erase the DTC memory. Refer to [EC-67, "HOW TO ERASE EMISSION-RELATED DIAGNOSTIC INFORMATION"](#).
7. Make sure DTC P0000 is displayed.
8. Run engine for at least 10 minutes at idle speed.
**Is the 1st trip DTC P0171 or P0174 detected?
Is it difficult to start engine?**

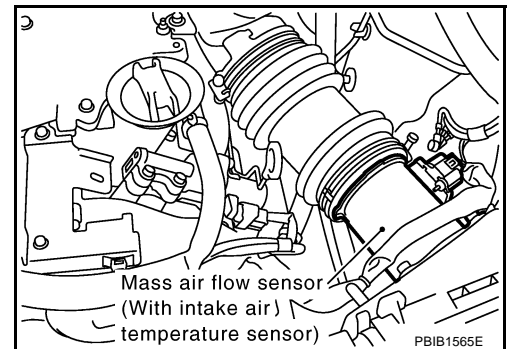

Yes or No

- Yes >> Perform trouble diagnosis for DTC P0171 or P0174. Refer to [EC-256](#).
- No >> GO TO 3.

3. CHECK HO2S2 GROUND CIRCUIT FOR OPEN AND SHORT

1. Turn ignition switch OFF.
2. Disconnect heated oxygen sensor 2 harness connector.
3. Disconnect ECM harness connector.
4. Check harness continuity between HO2S2 terminal 4 and ECM terminal 78.
Refer to Wiring Diagram.

Continuity should exist.

5. Also check harness for short to ground and short to power.

OK or NG

- OK >> GO TO 4.
- NG >> Repair open circuit or short to ground or short to power in harness or connectors.

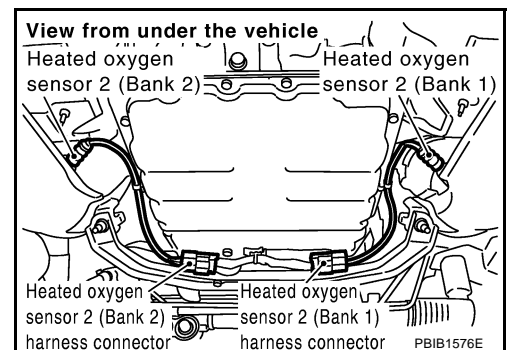

4. CHECK HO2S2 INPUT SIGNAL CIRCUIT FOR OPEN AND SHORT

1. Check harness continuity between ECM terminal and HO2S2 terminal as follows.
Refer to Wiring Diagram.

DTC	Terminals		Bank
	ECM	Sensor	
P1147	74	1	1
P1167	55	1	2

Continuity should exist.

2. Check harness continuity between the following terminals and ground.
Refer to Wiring Diagram.

DTC	Terminals		Bank
	ECM	Sensor	
P1147	74	1	1
P1167	55	1	2

Continuity should not exist.

3. Also check harness for short to ground and short to power.

OK or NG

OK >> GO TO 5.

NG >> Repair open circuit or short to ground or short to power in harness or connectors.

5. CHECK HEATED OXYGEN SENSOR 2

Refer to [EC-465, "Component Inspection"](#) .

OK or NG

OK >> GO TO 6.

NG >> Replace malfunctioning heated oxygen sensor 2.

6. CHECK INTERMITTENT INCIDENT

Refer to [EC-135, "TROUBLE DIAGNOSIS FOR INTERMITTENT INCIDENT"](#) .

>> INSPECTION END

**Component Inspection
HEATED OXYGEN SENSOR 2**

ABS006UU

Ⓟ With CONSULT-II

1. Turn ignition switch ON and select "DATA MONITOR" mode with CONSULT-II.
2. Start engine and warm it up to the normal operating temperature.
3. Turn ignition switch OFF and wait at least 10 seconds.
4. Start engine and keep the engine speed between 3,500 and 4,000 rpm for at least 1 minute under no load.
5. Let engine idle for 1 minute.

DATA MONITOR	
MONITOR	NO DTC
ENG SPEED	XXX rpm
COOLAN TEMP/S	XXX °C

SEF174Y

6. Select "FUEL INJECTION" in "ACTIVE TEST" mode, and select "HO2S2 (B1)/(B2)" as the monitor item with CONSULT-II.

ACTIVE TEST	
FUEL INJECTION	25 %
MONITOR	
ENG SPEED	XXX rpm
HO2S1 (B1)	XXX V
HO2S2 (B1)	XXX V
HO2S1 MNTR (B1)	RICH
HO2S2 MNTR (B1)	RICH

SEF662Y

7. Check "HO2S2 (B1)/(B2)" at idle speed when adjusting "FUEL INJECTION" to $\pm 25\%$.

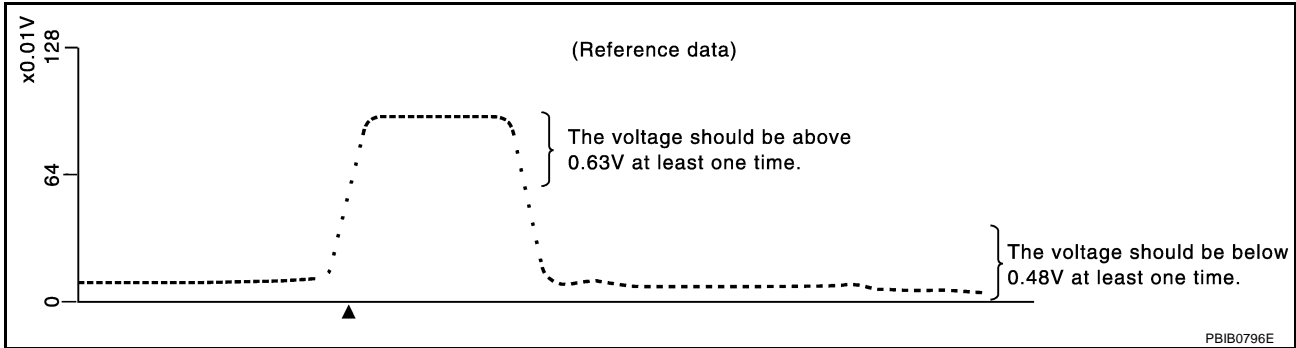

"HO2S2 (B1)/(B2)" should be above 0.63V at least once when the "FUEL INJECTION" is +25%.
 "HO2S2 (B1)/(B2)" should be below 0.48V at least once when the "FUEL INJECTION" is -25%.

CAUTION:

- Discard any heated oxygen sensor which has been dropped from a height of more than 0.5 m (19.7 in) onto a hard surface such as a concrete floor; use a new one.
- Before installing new oxygen sensor, clean exhaust system threads using Oxygen Sensor Thread Cleaner tool J-43897-18 or J-43897-12 and approved anti-seize lubricant.

Without CONSULT-II

1. Start engine and warm it up to the normal operating temperature.
2. Turn ignition switch OFF and wait at least 10 seconds.
3. Start engine and keep the engine speed between 3,500 and 4,000 rpm for at least 1 minute under no load.
4. Let engine idle for 1 minute.
5. Set voltmeter probes between ECM terminal 74 [HO2S2 (B1) signal] or 55 [HO2S2 (B2) signal] and ground.
6. Check the voltage when revving up to 4,000 rpm under no load at least 10 times.
 (Depress and release accelerator pedal as soon as possible.)
The voltage should be above 0.63V at least once during this procedure.
If the voltage is above 0.63V at step 6, step 7 is not necessary.
7. Keep vehicle at idling for 10 minutes, then check voltage. Or check the voltage when coasting from 80 km/h (50 MPH) in D position with "OD" OFF.
The voltage should be below 0.48V at least once during this procedure.
8. If NG, replace heated oxygen sensor 2.

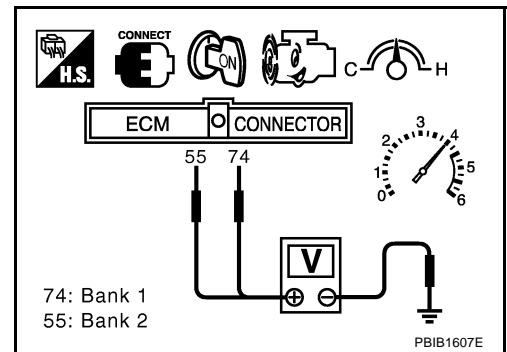

CAUTION:

- Discard any heated oxygen sensor which has been dropped from a height of more than 0.5 m (19.7 in) onto a hard surface such as a concrete floor; use a new one.
- Before installing new oxygen sensor, clean exhaust system threads using Oxygen Sensor Thread Cleaner tool J-43897-18 or J-43897-12 and approved anti-seize lubricant.

Removal and Installation
HEATED OXYGEN SENSOR 2

Refer to [EM-26, "EXHAUST MANIFOLD AND THREE WAY CATALYST"](#) .

A

EC

C

D

E

F

G

H

I

J

K

L

M

DTC P1148, P1168 CLOSED LOOP CONTROL

PFP:22690

On Board Diagnosis Logic

ABS006UW

These self-diagnoses have the one trip detection logic.

DTC No.	Trouble diagnosis name	DTC detecting condition	Possible cause
P1148 1148 (Bank 1)	Closed loop control function	The closed loop control function for bank 1 does not operate even when vehicle is driving in the specified condition.	<ul style="list-style-type: none"> ● The heated oxygen sensor 1 circuit is open or shorted. ● Heated oxygen sensor 1 ● Heated oxygen sensor heater
P1168 1168 (Bank 2)		The closed loop control function for bank 2 does not operate even when vehicle is driving in the specified condition.	

DTC Confirmation Procedure

ABS006UX

CAUTION:

Always drive vehicle at a safe speed.

NOTE:

If DTC Confirmation Procedure has been previously conducted, always turn ignition switch OFF and wait at least 10 seconds before conducting the next test.

TESTING CONDITION:

- Never raise engine speed above 3,600 rpm during the DTC Confirmation Procedure. If the engine speed limit is exceeded, retry the procedure from step 2.
- Before performing the following procedure, confirm that battery voltage is more than 11V at idle.

WITH CONSULT-II

1. Start engine and warm it up to normal operating temperature.
2. Select "DATA MONITOR" mode with CONSULT-II.
3. Hold engine speed at 2,000 rpm and check one of the following.
 - "HO2S1 (B1)/(B2)" voltage should go above 0.70V at least once.
 - "HO2S1 (B1)/(B2)" voltage should go below 0.21V at least once. If the check result is NG, perform [EC-469, "Diagnostic Procedure"](#). If the check result is OK, perform the following step.
4. Let engine idle at least 5 minutes.
5. Maintain the following condition at least 50 consecutive seconds.

DATA MONITOR	
MONITOR	NO DTC
ENG SPEED	XXX rpm
COOLAN TEMP/S	XXX °C
HO2S1 (B1)	XXX V
HO2S1 (B2)	XXX V

SEC011C

B/FUEL SCHDL	2.5 msec or more
ENG SPEED	More than 1,500 rpm
Selector lever	Suitable position
VHCL SPEED SE	More than 70 km/h (43 MPH)

During this test, P0132 and/or P0152 may be displayed on CONSULT-II screen.

6. If DTC is detected, go to [EC-469, "Diagnostic Procedure"](#).

Overall Function Check

ABS006UY

Use this procedure to check the overall function of the closed loop control. During this check, a DTC might not be confirmed.

WITH GST

1. Start engine and warm it up to normal operating temperature.
2. Set voltmeter probes between ECM terminal 35 [HO2S1 (B1) signal] or 16 [HO2S1 (B2) signal] and ground.
3. Check the following with engine speed held at 2,000 rpm constant under no-load.
 - The voltage should go above 0.70V at least once.
 - The voltage should go below 0.21V at least once.
4. If NG, go to [EC-469, "Diagnostic Procedure"](#) .

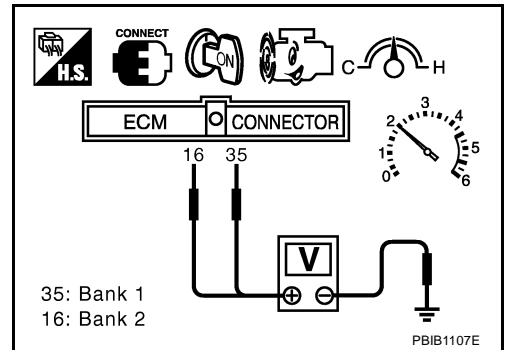

Diagnostic Procedure

Perform trouble diagnosis for DTC P0133, P0153. Refer to [EC-220, "Diagnostic Procedure"](#) .

A
EC
C
D
E
F
G
H
I
J
K
L
M

DTC P1211 TCS CONTROL UNIT

PFP:47850

Description

ABS006V0

The malfunction information related to TCS is transferred through the CAN communication line from “ABS actuator and electric unit (control unit)” to ECM.

Be sure to erase the malfunction information such as DTC not only for “ABS actuator and electric unit (control unit)” but also for ECM after TCS related repair.

On Board Diagnosis Logic

ABS006V1

Freeze frame data is not stored in the ECM for this self-diagnosis. The MIL will not light up for this self-diagnosis.

DTC No.	Trouble diagnosis name	DTC detecting condition	Possible cause
P1211 1211	TCS control unit	ECM receives a malfunction information from “ABS actuator and electric unit (Control unit)”.	<ul style="list-style-type: none"> ● ABS actuator and electric unit (control unit) ● TCS related parts

DTC Confirmation Procedure

ABS006V2

TESTING CONDITION:

Before performing the following procedure, confirm that battery voltage is more than 10.5V at idle.

WITH CONSULT-II

1. Turn ignition switch ON.
2. Select “DATA MONITOR” mode with CONSULT-II.
3. Start engine and let it idle for at least 60 seconds.
4. If 1st trip DTC is detected, go to [EC-470, "Diagnostic Procedure"](#)

DATA MONITOR	
MONITOR	NO DTC
ENG SPEED	XXX rpm

SEF058Y

WITH GST

Follow the procedure “WITH CONSULT-II” above.

Diagnostic Procedure

ABS006V3

Go to [BRC-12, "TROUBLE DIAGNOSIS"](#) .

DTC P1212 TCS COMMUNICATION LINE

PFP:47850

Description

ABS006V4

NOTE:

If DTC P1212 is displayed with DTC U1000 or U1001, first perform the trouble diagnosis for DTC U1000, U1001. Refer to [EC-142](#).

This CAN communication line is used to control the smooth engine operation during the TCS operation. Pulse signals are exchanged between ECM and "ABS actuator and electric unit (control unit)".

Be sure to erase the malfunction information such as DTC not only for "ABS actuator and electric unit (control unit)" but also for ECM after TCS related repair.

On Board Diagnosis Logic

ABS006V5

Freeze frame data is not stored in the ECM for this self-diagnosis. The MIL will not light up for this self-diagnosis.

DTC No.	Trouble diagnosis name	DTC detecting condition	Possible cause
P1212 1212	TCS communication line	ECM can not receive the information from "ABS actuator and electric unit (control unit)".	<ul style="list-style-type: none"> ● Harness or connectors (The CAN communication line is open or shorted.) ● ABS actuator and electric unit (control unit) ● Dead (Weak) battery

DTC Confirmation Procedure

ABS006V6

TESTING CONDITION:

Before performing the following procedure, confirm that battery voltage is more than 10.5V at idle.

Ⓜ WITH CONSULT-II

1. Turn ignition switch ON.
2. Select "DATA MONITOR" mode with CONSULT-II.
3. Start engine and let it idle for at least 10 seconds.
4. If a 1st trip DTC is detected, go to [EC-471](#), "Diagnostic Procedure".

DATA MONITOR	
MONITOR	NO DTC
ENG SPEED	XXX rpm

SEF058Y

Ⓜ WITH GST

Follow the procedure "WITH CONSULT-II" above.

Diagnostic Procedure

ABS006V7

1. CHECK "ABS ACTUATOR AND ELECTRIC UNIT (CONTROL UNIT)"

Refer to [BRC-12](#), "TROUBLE DIAGNOSIS".

>> INSPECTION END

DTC P1217 ENGINE OVER TEMPERATURE

[VQ35DE]

DTC P1217 ENGINE OVER TEMPERATURE

PFP:00000

Description SYSTEM DESCRIPTION

ABS00DAP

NOTE:

If DTC P1217 is displayed with DTC U1000 or U1001, first perform the trouble diagnosis for DTC U1000, U1001. Refer to [EC-142](#).

Cooling Fan Control

Sensor	Input Signal to ECM	ECM function	Actuator
Crankshaft position sensor (POS) Camshaft position sensor (PHASE)	Engine speed*1	Cooling fan control	IPDM E/R (Cooling fan relays)
Battery	Battery voltage*1		
Wheel sensor*2	Vehicle speed		
Engine coolant temperature sensor	Engine coolant temperature		
Air conditioner switch*2	Air conditioner ON signal		
Refrigerant pressure sensor	Refrigerant pressure		

*1: The ECM determines the start signal status by the signals of engine speed and battery voltage.

*2: This signal is sent to ECM through CAN communication line.

The ECM controls the cooling fan corresponding to the vehicle speed, engine coolant temperature, refrigerant pressure, and air conditioner ON signal. The control system has 4-step control [HIGH/MIDDLE/LOW/OFF].

Cooling Fan Operation

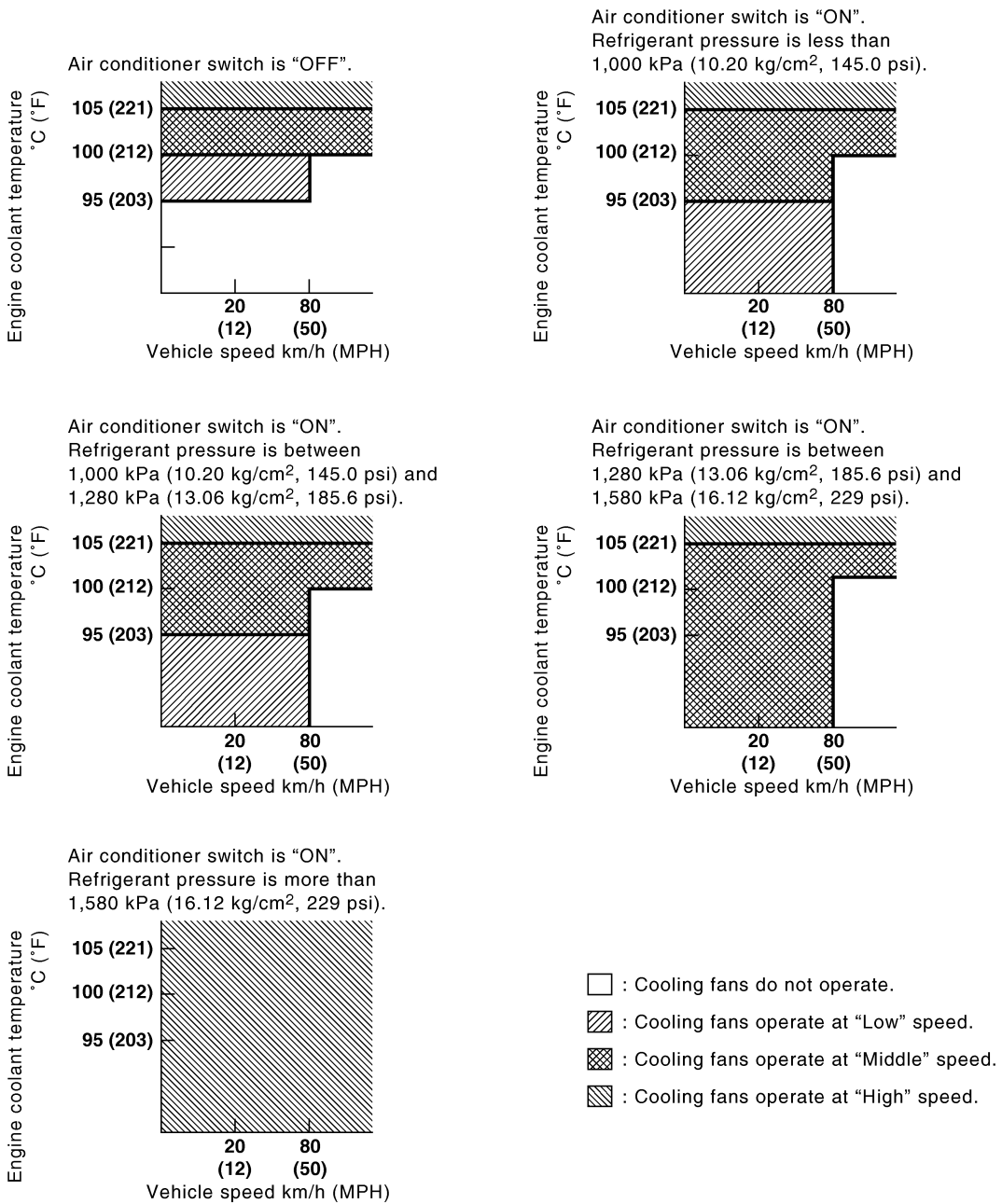

PBIB2023E

A
EC
C
D
E
F
G
H
I
J
K
L
M

DTC P1217 ENGINE OVER TEMPERATURE

[VQ35DE]

Cooling Fan Relay Operation

The ECM controls cooling fan relays in the IPDM E/R through CAN communication line.

Cooling fan speed	Cooling fan relay		
	1	2	3
Stop (OFF)	OFF	OFF	OFF
Low (LOW)	OFF	ON	OFF
Middle (MID)	ON	OFF	OFF
High (HI)	ON	OFF	ON

COMPONENT DESCRIPTION

Cooling Fan Motor

The cooling fan operates at each speed when the current flows in the cooling fan motor as follows.

Cooling fan speed	Cooling fan motor terminals	
	(+)	(-)
Middle (MID)	1	3 and 4
	2	3 and 4
	1 and 2	3
	1 and 2	4
High (HI)	1 and 2	3 and 4

The cooling fan operates at low (LOW) speed when cooling fan motors-1 and -2 are circuited in series under middle speed condition.

DTC P1217 ENGINE OVER TEMPERATURE

[VQ35DE]

CONSULT-II Reference Value in Data Monitor Mode

ABS006V9

Specification data are reference values.

MONITOR ITEM	CONDITION		SPECIFICATION
AIR COND SIG	● Engine: After warming up, idle the engine	Air conditioner switch: OFF	OFF
		Air conditioner switch: ON (Compressor operates.)	ON
COOLING FAN	● Engine: After warming up, idle the engine ● Air conditioner switch: OFF	Engine coolant temperature is 94°C (201°F) or less	OFF
		Engine coolant temperature is between 95°C (203°F) and 99°C (210°F)	LOW
		Engine coolant temperature is between 100°C (212°F) and 104°C (219°F)	MID
		Engine coolant temperature is 105°C (221°F) or more	HI

On Board Diagnosis Logic

ABS006VA

If the cooling fan or another component in the cooling system malfunctions, engine coolant temperature will rise.

When the engine coolant temperature reaches an abnormally high temperature condition, a malfunction is indicated.

This self-diagnosis has the one trip detection logic.

DTC No.	Trouble diagnosis name	DTC detecting condition	Possible cause
P1217 1217	Engine over temperature (Overheat)	<ul style="list-style-type: none"> ● Cooling fan does not operate properly (Overheat). ● Cooling fan system does not operate properly (Overheat). ● Engine coolant level was not added to the system using the proper filling method. ● Engine coolant is not within the specified range. 	<ul style="list-style-type: none"> ● Harness or connectors (The cooling fan circuit is open or shorted.) ● IPDM E/R ● Cooling fan ● Radiator hose ● Radiator ● Radiator cap ● Water pump ● Thermostat <p>For more information, refer to EC-484, "Main 12 Causes of Overheating".</p>

CAUTION:

When a malfunction is indicated, be sure to replace the coolant. Refer to [CO-11, "Changing Engine Coolant"](#). Also, replace the engine oil. Refer to [LU-9, "Changing Engine Oil"](#).

1. Fill radiator with coolant up to specified level with a filling speed of 2 liters per minute. Be sure to use coolant with the proper mixture ratio. Refer to [MA-13, "Anti-Freeze Coolant Mixture Ratio"](#).
2. After refilling coolant, run engine to ensure that no water-flow noise is emitted.

Overall Function Check

ABS006VB

Use this procedure to check the overall function of the cooling fan. During this check, a DTC might not be confirmed.

WARNING:

Never remove the radiator cap when the engine is hot. Serious burns could be caused by high pressure fluid escaping from the radiator.

Wrap a thick cloth around cap. Carefully remove the cap by turning it a quarter turn to allow built-up pressure to escape. Then turn the cap all the way off.

DTC P1217 ENGINE OVER TEMPERATURE

[VQ35DE]

CONSULT-II WITH CONSULT-II

1. Check the coolant level in the reservoir tank and radiator.
Allow engine to cool before checking coolant level.
If the coolant level in the reservoir tank and/or radiator is below the proper range, skip the following steps and go to [EC-479, "PROCEDURE A"](#).
2. Confirm whether customer filled the coolant or not. If customer filled the coolant, skip the following steps and go to [EC-479, "PROCEDURE A"](#).
3. Turn ignition switch ON.
4. Perform "COOLING FAN" in "ACTIVE TEST" mode with CONSULT-II.
5. If the results are NG, go to [EC-479, "PROCEDURE A"](#).

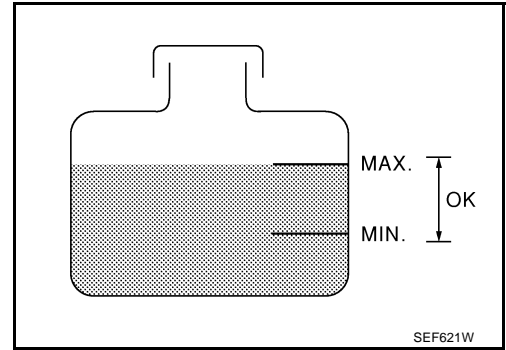

ACTIVE TEST	
COOLING FAN	OFF
MONITOR	
COOLAN TEMP/S	XXX °C

SEF646X

GST WITH GST

1. Check the coolant level in the reservoir tank and radiator.
Allow engine to cool before checking coolant level.
If the coolant level in the reservoir tank and/or radiator is below the proper range, skip the following steps and go to [EC-479, "PROCEDURE A"](#).
2. Confirm whether customer filled the coolant or not. If customer filled the coolant, skip the following steps and go to [EC-479, "PROCEDURE A"](#).
3. Perform IPDM E/R auto active test and check cooling fan motors operation, refer to [PG-24, "Auto Active Test"](#)
4. If NG, go to [EC-479, "PROCEDURE A"](#).

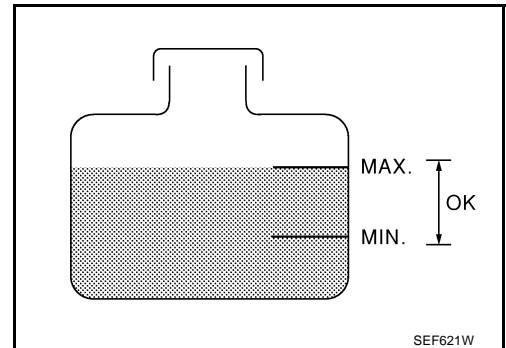

DTC P1217 ENGINE OVER TEMPERATURE

[VQ35DE]

Wiring Diagram

ABS006VC

EC-COOL/F-01

- : DETECTABLE LINE FOR DTC
- - -** : NON-DETECTABLE LINE FOR DTC
- ▬▬▬** : DATA LINE

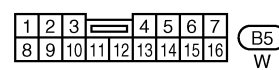
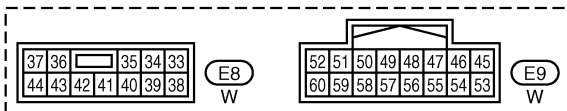
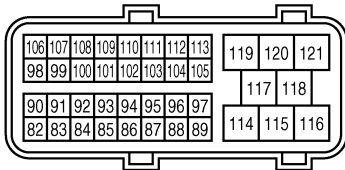
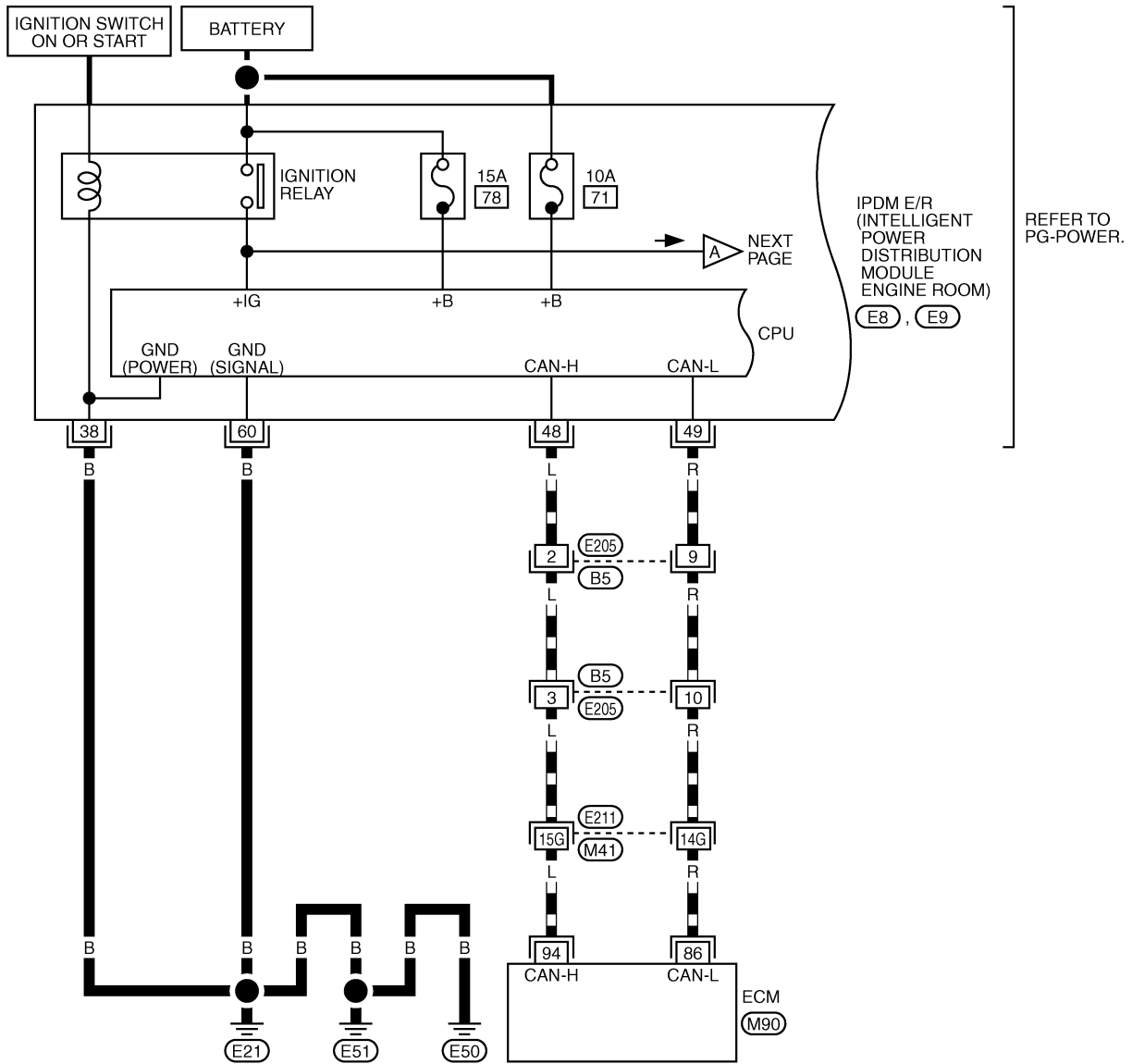

REFER TO THE FOLLOWING.
 (E21) -SUPER MULTIPLE JUNCTION (SMJ)

TBWM0306E

DTC P1217 ENGINE OVER TEMPERATURE

[VQ35DE]

— : DETECTABLE LINE FOR DTC
 — : NON-DETECTABLE LINE FOR DTC

EC-COOL/F-02

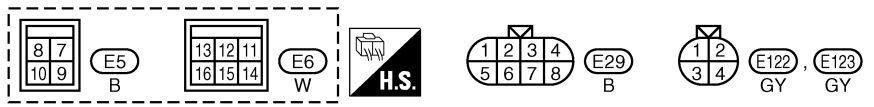
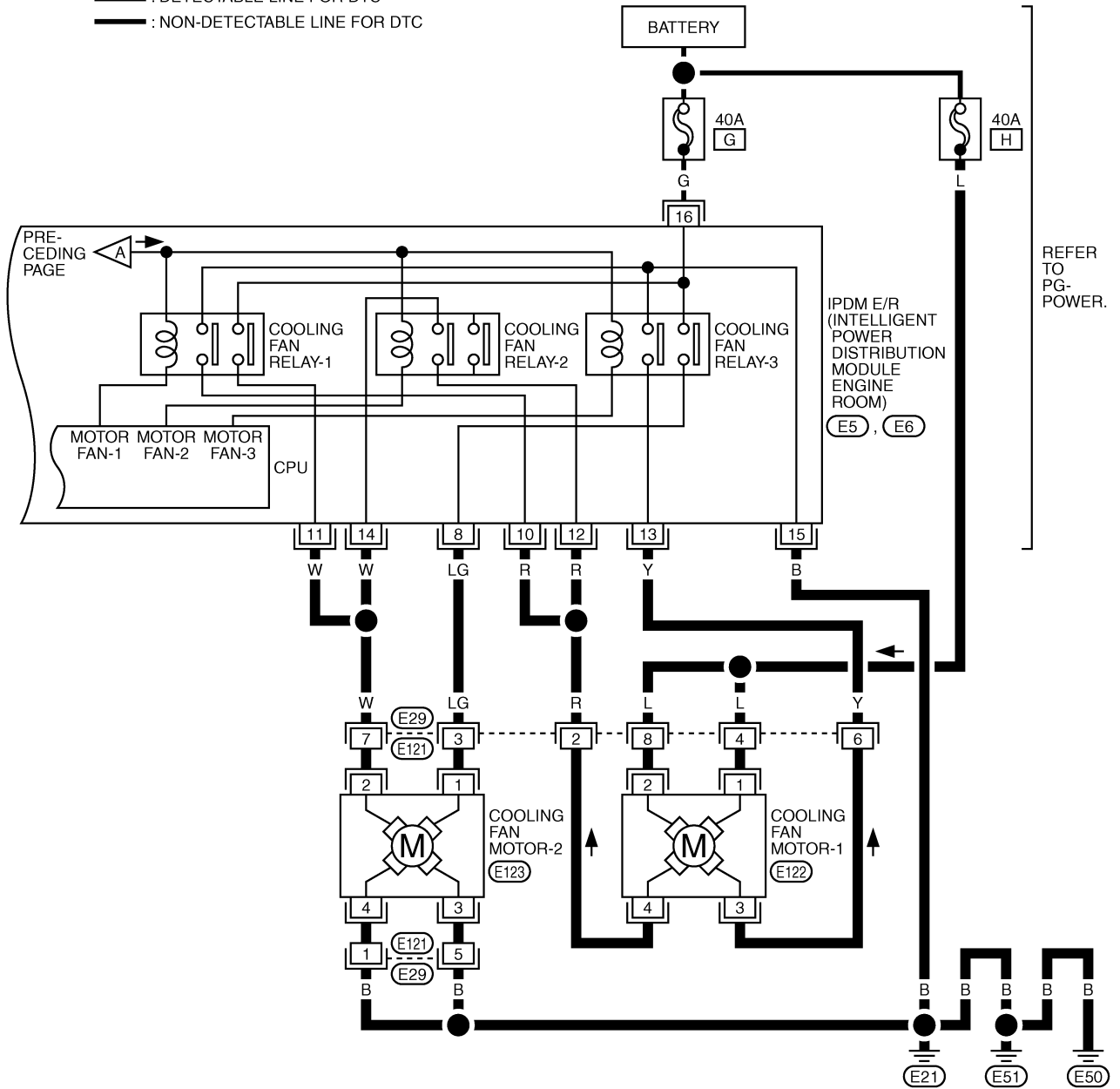

TBWM0307E

Diagnostic Procedure PROCEDURE A

1. INSPECTION START

Do you have CONSULT-II?

Yes or No

- Yes >> GO TO 2.
- No >> GO TO 3.

2. CHECK COOLING FAN OPERATION

Ⓟ With CONSULT-II

1. Start engine and let it idle.
2. Select "COOLING FAN" in "ACTIVE TEST" mode with CONSULT-II.
3. Make sure that cooling fans-1 and -2 operate at each speed (LOW/MID/HI).

OK or NG

- OK >> GO TO 4.
- NG >> Check cooling fan control circuit. (Go to [EC-481, "PROCEDURE B"](#).)

ACTIVE TEST	
COOLING FAN	LOW
MONITOR	
COOLANT TEMP/S	XXX °C

SEF784Z

3. CHECK COOLING FAN OPERATION

⊗ Without CONSULT-II

1. Perform IPDM E/R auto active test and check cooling fan motors operation, refer to [PG-24, "Auto Active Test"](#).
2. Make sure that cooling fans-1 and -2 operate at each speed (Low/Middle/High).

OK or NG

- OK >> GO TO 4.
- NG >> Check cooling fan control circuit. (Go to [EC-481, "PROCEDURE B"](#).)

4. CHECK COOLING SYSTEM FOR LEAK

Apply pressure to the cooling system with a tester, and check if the pressure drops.

Testing pressure: 157 kPa (1.6 kg/cm² , 23 psi)

CAUTION:

Higher than the specified pressure may cause radiator damage. Pressure should not drop.

OK or NG

- OK >> GO TO 5.
- NG >> Check the following for leak. Refer to [CO-11, "LEVEL CHECK"](#).
 - Hose
 - Radiator
 - Water pump

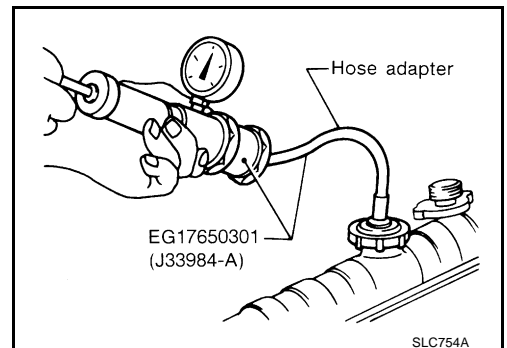

5. CHECK RADIATOR CAP

Apply pressure to cap with a tester.

Radiator cap relief pressure: 59 - 98 kPa (0.6 - 1.0 kg/cm², 9 - 14 psi)

OK or NG

OK >> GO TO 6.

NG >> Replace radiator cap.

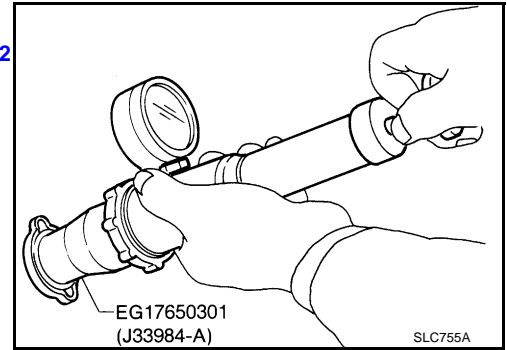

6. CHECK THERMOSTAT

1. Check valve seating condition at normal room temperatures.
It should seat tightly.

2. Check valve opening temperature and valve lift.

Valve opening temperature: 76.5°C (170°F) [standard]

Valve lift: More than 8.6 mm/90°C (0.339 in/194°F)

3. Check if valve is closed at 5°C (9°F) below valve opening temperature.

For details, refer to [CO-26, "WATER INLET AND THERMOSTAT ASSEMBLY"](#).

OK or NG

OK >> GO TO 7.

NG >> Replace thermostat

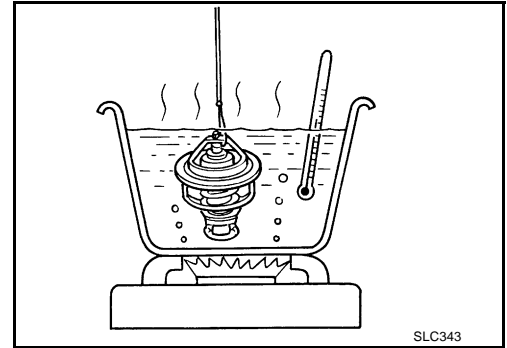

7. CHECK ENGINE COOLANT TEMPERATURE SENSOR

Refer to [EC-189, "Component Inspection"](#).

OK or NG

OK >> GO TO 8.

NG >> Replace engine coolant temperature sensor.

8. CHECK MAIN 12 CAUSES

If the cause cannot be isolated, go to [EC-484, "Main 12 Causes of Overheating"](#).

>> **INSPECTION END**

PROCEDURE B**1. CHECK COOLING FAN POWER SUPPLY CIRCUIT**

1. Turn ignition switch OFF.
2. Disconnect IPDM E/R harness connector E6.
3. Check voltage between IPDM E/R terminal 16 and ground with CONSULT-II or tester.

Voltage: Battery voltage

OK or NG

- OK >> GO TO 3.
 NG >> GO TO 2.

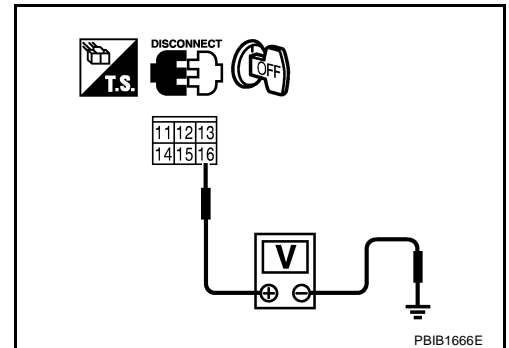
**2. DETECT MALFUNCTIONING PART**

Check the following.

- 40A fusible link
- Harness for open or short between IPDM E/R and battery

>> Repair open circuit or short to ground in harness or connectors.

3. CHECK COOLING FAN GROUND CIRCUIT

1. Check harness continuity between IPDM E/R terminal 15 and ground. Refer to Wiring Diagram.

Continuity should exist.

2. Also check harness for short to power.

OK or NG

- OK >> GO TO 4.
 NG >> Repair open circuit or short to power in harness or connectors.

4. CHECK COOLING FAN MOTOR-1 CIRCUIT-I

1. Disconnect cooling fan motor-1 harness connector.

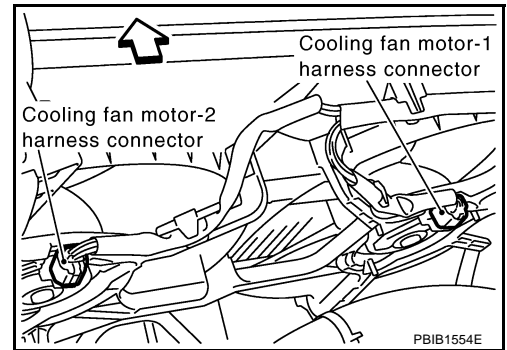

2. Check voltage between cooling fan motor-1 terminals 1, 2 and ground with CONSULT-II or tester.

Voltage: Battery voltage

OK or NG

- OK >> GO TO 6.
- NG >> GO TO 5.

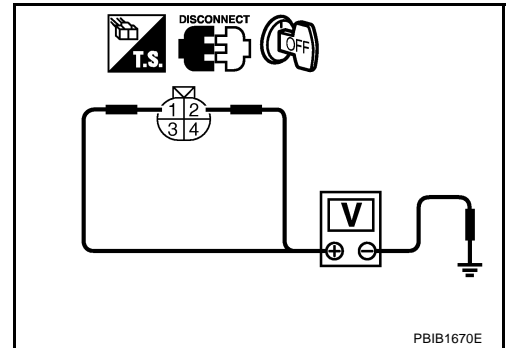

5. DETECT MALFUNCTIONING PART

Check the following.

- 40A fusible link
- Harness connectors E29, E121
- Harness for open or short between cooling fan motor-1 and battery

>> Repair open circuit or short to ground in harness or connectors.

6. CHECK COOLING FAN MOTOR-1 CIRCUIT-II

1. Check harness continuity between cooling fan motor-1 terminal 3 and IPDM E/R terminal 13, cooling fan motor-1 terminal 4 and IPDM E/R terminals 10, 12. Refer to Wiring diagram.

Continuity should exist.

2. Also check harness for short to ground and short to power.

OK or NG

- OK >> GO TO 8.
- NG >> GO TO 7.

7. DETECT MALFUNCTIONING PART

Check the following.

- Harness connectors E29, E121
- Harness for open or short between cooling fan motor-1 and IPDM E/R

>> Repair open circuit or short to ground or short to power in harness or connectors.

8. CHECK COOLING FAN MOTOR-2 CIRCUIT-I

1. Disconnect cooling fan motor-2 harness connector.
2. Check harness continuity between cooling fan motor-2 terminals 3, 4 and ground.
Refer to Wiring diagram.

Continuity should exist.

3. Also check harness short to power.

OK or NG

- OK >> GO TO 10.
NG >> GO TO 9.

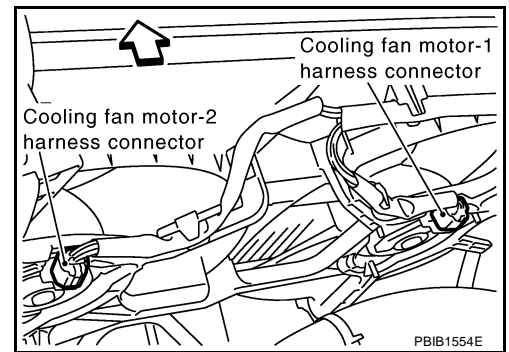

9. DETECT MALFUNCTIONING PART

Check the following.

- Harness connectors E29, E121
- Harness for open or short between cooling fan motor-2 and ground

>> Repair open circuit or short to power in harness or connectors.

10. CHECK COOLING FAN MOTOR-2 CIRCUIT-II

1. Check harness continuity between cooling fan motor-2 terminal 1 and IPDM E/R terminal 8, cooling fan motor-2 terminal 2 and IPDM E/R terminals 11, 14.
Refer to Wiring Diagram.

Continuity should exist.

2. Also check harness for short to ground and short to power.

OK or NG

- OK >> GO TO 12.
NG >> GO TO 11.

11. DETECT MALFUNCTIONING PART

Check the following.

- Harness connectors E29, E121
- Harness for open or short between cooling fan motor-2 and IPDM E/R

>> Repair open circuit or short to ground or short to power in harness or connectors.

12. CHECK COOLING FAN MOTORS

Refer to [EC-484, "Component Inspection"](#) .

OK or NG

- OK >> GO TO 13.
NG >> Replace cooling fan motors.

13. CHECK INTERMITTENT INCIDENT

Perform [EC-135, "TROUBLE DIAGNOSIS FOR INTERMITTENT INCIDENT"](#) .

OK or NG

- OK >> Replace IPDM E/R. Refer to [PG-18, "IPDM E/R \(INTELLIGENT POWER DISTRIBUTION MODULE ENGINE ROOM\)"](#) .
NG >> Repair or replace harness or connector.

Main 12 Causes of Overheating

ABS006VE

Engine	Step	Inspection item	Equipment	Standard	Reference page
OFF	1	<ul style="list-style-type: none"> ● Blocked radiator ● Blocked condenser ● Blocked radiator grille ● Blocked bumper 	● Visual	No blocking	—
	2	● Coolant mixture	● Coolant tester	50 - 50% coolant mixture	MA-13
	3	● Coolant level	● Visual	Coolant up to MAX level in reservoir tank and radiator filler neck	CO-11
	4	● Radiator cap	● Pressure tester	59 - 98 kPa (0.6 - 1.0 kg/cm ² , 9 - 14 psi) (Limit)	CO-15
ON*2	5	● Coolant leaks	● Visual	No leaks	CO-11
ON*2	6	● Thermostat	● Touch the upper and lower radiator hoses	Both hoses should be hot	CO-26
ON*1	7	● Cooling fan	● CONSULT-II	Operating	See trouble diagnosis for DTC P1217 (EC-472).
OFF	8	● Combustion gas leak	● Color checker chemical tester 4 Gas analyzer	Negative	—
ON*3	9	● Coolant temperature gauge	● Visual	Gauge less than 3/4 when driving	—
		● Coolant overflow to reservoir tank	● Visual	No overflow during driving and idling	CO-11
OFF*4	10	● Coolant return from reservoir tank to radiator	● Visual	Should be initial level in reservoir tank	CO-11
OFF	11	● Cylinder head	● Straight gauge feeler gauge	0.1 mm (0.004 in) Maximum distortion (warping)	EM-100
	12	● Cylinder block and pistons	● Visual	No scuffing on cylinder walls or piston	EM-120

*1: Turn the ignition switch ON.

*2: Engine running at 3,000 rpm for 10 minutes.

*3: Drive at 90 km/h (55 MPH) for 30 minutes and then let idle for 10 minutes.

*4: After 60 minutes of cool down time.

For more information, refer to [CO-7, "OVERHEATING CAUSE ANALYSIS"](#).

Component Inspection COOLING FAN MOTORS-1 AND -2

ABS006VF

1. Disconnect cooling fan motor harness connectors.
2. Supply cooling fan motor terminals with battery voltage and check operation.

Cooling fan speed	Cooling fan motor terminals	
	(+)	(-)
Middle (MID)	1	3 and 4
	2	3 and 4
	1 and 2	3
	1 and 2	4
High (HI)	1 and 2	3 and 4

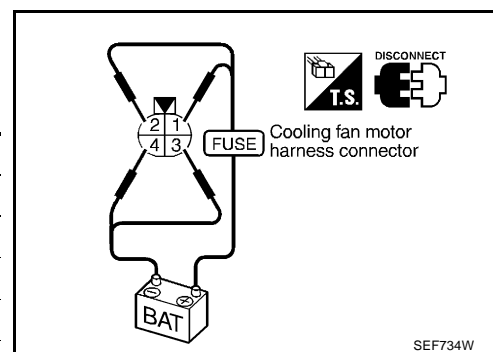

Cooling fan motor should operate.

If NG, replace cooling fan motor.

DTC P1225 TP SENSOR

PF16:16119

Component Description

ABS006VG

Electric throttle control actuator consists of throttle control motor, throttle position sensor, etc. The throttle position sensor responds to the throttle valve movement.

The throttle position sensor has the two sensors. These sensors are a kind of potentiometers which transform the throttle valve position into output voltage, and emit the voltage signal to the ECM. In addition, these sensors detect the opening and closing speed of the throttle valve and feed the voltage signals to the ECM. The ECM judges the current opening angle of the throttle valve from these signals and the ECM controls the throttle control motor to make the throttle valve opening angle properly in response to driving condition.

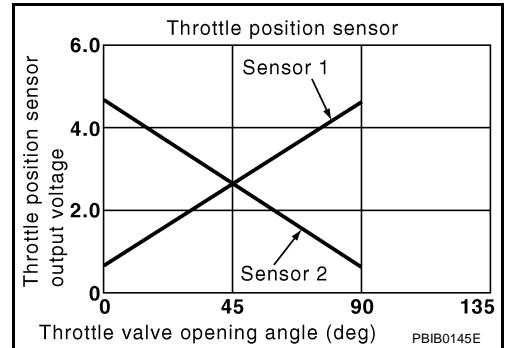

On Board Diagnosis Logic

ABS006VH

The MIL will not light up for this diagnosis.

DTC No.	Trouble diagnosis name	DTC detecting condition	Possible cause
P1225 1225	Closed throttle position learning performance problem	Closed throttle position learning value is excessively low.	<ul style="list-style-type: none"> Electric throttle control actuator (TP sensor 1 and 2)

DTC Confirmation Procedure

ABS006VI

NOTE:

If DTC Confirmation Procedure has been previously conducted, always turn ignition switch OFF and wait at least 10 seconds before conducting the next test.

TESTING CONDITION:

Before performing the following procedure, confirm that battery voltage is more than 10V at idle.

WITH CONSULT-II

1. Turn ignition switch ON.
2. Select "DATA MONITOR" mode with CONSULT-II.
3. Turn ignition switch OFF, wait at least 10 seconds.
4. Turn ignition switch ON.
5. If 1st trip DTC is detected, go to [EC-486, "Diagnostic Procedure"](#)

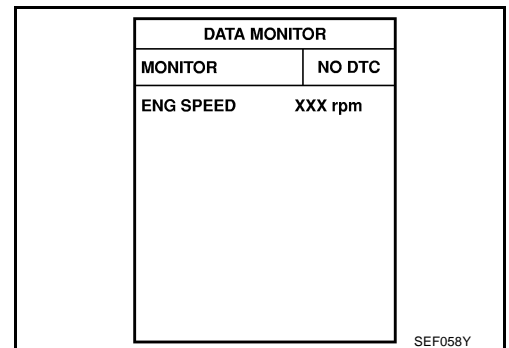

WITH GST

Follow the procedure "WITH CONSULT-II" above.

Diagnostic Procedure

ABS006VJ

1. CHECK ELECTRIC THROTTLE CONTROL ACTUATOR VISUALLY

1. Turn ignition switch OFF.
2. Remove the intake air duct.
3. Check if foreign matter is caught between the throttle valve and the housing.

OK or NG

OK >> GO TO 2.

NG >> Remove the foreign matter and clean the electric throttle control actuator inside.

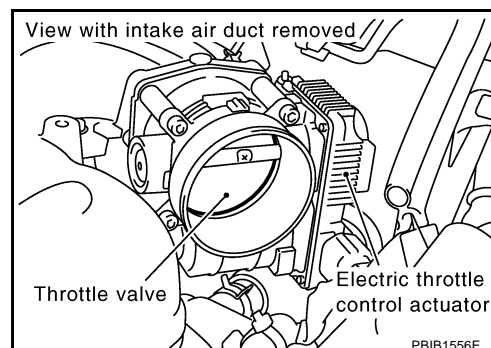
**2. REPLACE ELECTRIC THROTTLE CONTROL ACTUATOR**

1. Replace the electric throttle control actuator.
2. Perform [EC-49, "Throttle Valve Closed Position Learning"](#) .
3. Perform [EC-49, "Idle Air Volume Learning"](#) .

>> INSPECTION END

**Removal and Installation
ELECTRIC THROTTLE CONTROL ACTUATOR**

ABS006VK

Refer to [EM-19, "INTAKE MANIFOLD COLLECTOR"](#) .

DTC P1226 TP SENSOR

PF16:16119

Component Description

ABS006VL

Electric throttle control actuator consists of throttle control motor, throttle position sensor, etc. The throttle position sensor responds to the throttle valve movement.

The throttle position sensor has the two sensors. These sensors are a kind of potentiometers which transform the throttle valve position into output voltage, and emit the voltage signal to the ECM. In addition, these sensors detect the opening and closing speed of the throttle valve and feed the voltage signals to the ECM. The ECM judges the current opening angle of the throttle valve from these signals and the ECM controls the throttle control motor to make the throttle valve opening angle properly in response to driving condition.

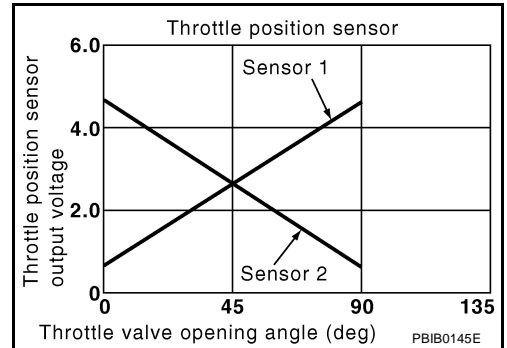

On Board Diagnosis Logic

ABS006VM

The MIL will not light up for this diagnosis.

DTC No.	Trouble diagnosis name	DTC detecting condition	Possible cause
P1226 1226	Closed throttle position learning performance problem	Closed throttle position learning is not performed successfully, repeatedly.	<ul style="list-style-type: none"> Electric throttle control actuator (TP sensor 1 and 2)

DTC Confirmation Procedure

ABS006VN

NOTE:

If DTC Confirmation Procedure has been previously conducted, always turn ignition switch OFF and wait at least 10 seconds before conducting the next test.

TESTING CONDITION:

Before performing the following procedure, confirm that battery voltage is more than 10V at idle.

WITH CONSULT-II

1. Turn ignition switch ON.
2. Select "DATA MONITOR" mode with CONSULT-II.
3. Turn ignition switch OFF, wait at least 10 seconds.
4. Turn ignition switch ON.
5. Repeat steps 3 and 4 for 32 times.
6. If 1st trip DTC is detected, go to [EC-488, "Diagnostic Procedure"](#)

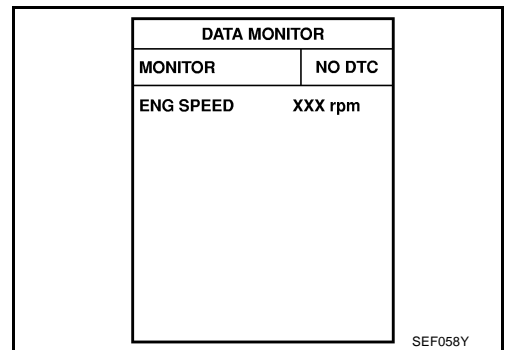

WITH GST

Follow the procedure "WITH CONSULT-II" above.

Diagnostic Procedure

ABS006VO

1. CHECK ELECTRIC THROTTLE CONTROL ACTUATOR VISUALLY

1. Turn ignition switch OFF.
2. Remove the intake air duct.
3. Check if foreign matter is caught between the throttle valve and the housing.

OK or NG

OK >> GO TO 2.

NG >> Remove the foreign matter and clean the electric throttle control actuator inside.

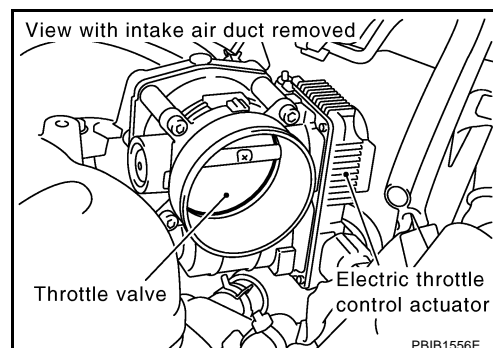
**2. REPLACE ELECTRIC THROTTLE CONTROL ACTUATOR**

1. Replace the electric throttle control actuator.
2. Perform [EC-49, "Throttle Valve Closed Position Learning"](#) .
3. Perform [EC-49, "Idle Air Volume Learning"](#) .

>> INSPECTION END

**Removal and Installation
ELECTRIC THROTTLE CONTROL ACTUATOR**

ABS006VP

Refer to [EM-19, "INTAKE MANIFOLD COLLECTOR"](#) .

DTC P1229 SENSOR POWER SUPPLY

PFP:16119

On Board Diagnosis Logic

ABS00CHP

This self-diagnosis has the one trip detection logic.

DTC No.	Trouble diagnosis name	DTC detecting condition	Possible cause
P1229 1229	Sensor power supply circuit short	ECM detects a voltage of power source for sensor is excessively low or high.	<ul style="list-style-type: none"> ● Harness or connectors (APP sensor 1 circuit is shorted.) (PSP sensor circuit is shorted.) (Refrigerant pressure sensor circuit is shorted.) (EVAP control system pressure sensor circuit is shorted.) ● Accelerator pedal position sensor (APP sensor 1) ● EVAP control system pressure sensor ● Power steering pressure sensor ● Refrigerant pressure sensor

FAIL-SAFE MODE

When the malfunction is detected, ECM enters fail-safe mode and the MIL lights up.

Engine operation condition in fail-safe mode

ECM stops the electric throttle control actuator control, throttle valve is maintained at a fixed opening (approx. 5 degrees) by the return spring.

DTC Confirmation Procedure

ABS00CHQ

NOTE:

If DTC Confirmation Procedure has been previously conducted, always turn ignition switch OFF and wait at least 10 seconds before conducting the next test.

TESTING CONDITION:

Before performing the following procedure, confirm that battery voltage is more than 10V at idle.

WITH CONSULT-II

1. Turn ignition switch ON.
2. Select "DATA MONITOR" mode with CONSULT-II.
3. Start engine and let it idle for 1 second.
4. If DTC is detected, go to [EC-491, "Diagnostic Procedure"](#) .

DATA MONITOR	
MONITOR	NO DTC
ENG SPEED	XXX rpm

SEF058Y

WITH GST

Follow the procedure "WITH CONSULT-II" above.

DTC P1229 SENSOR POWER SUPPLY

[VQ35DE]

ABS00CHR

Wiring Diagram

EC-SEN/PW-01

: DETECTABLE LINE FOR DTC
 : NON-DETECTABLE LINE FOR DTC

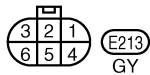
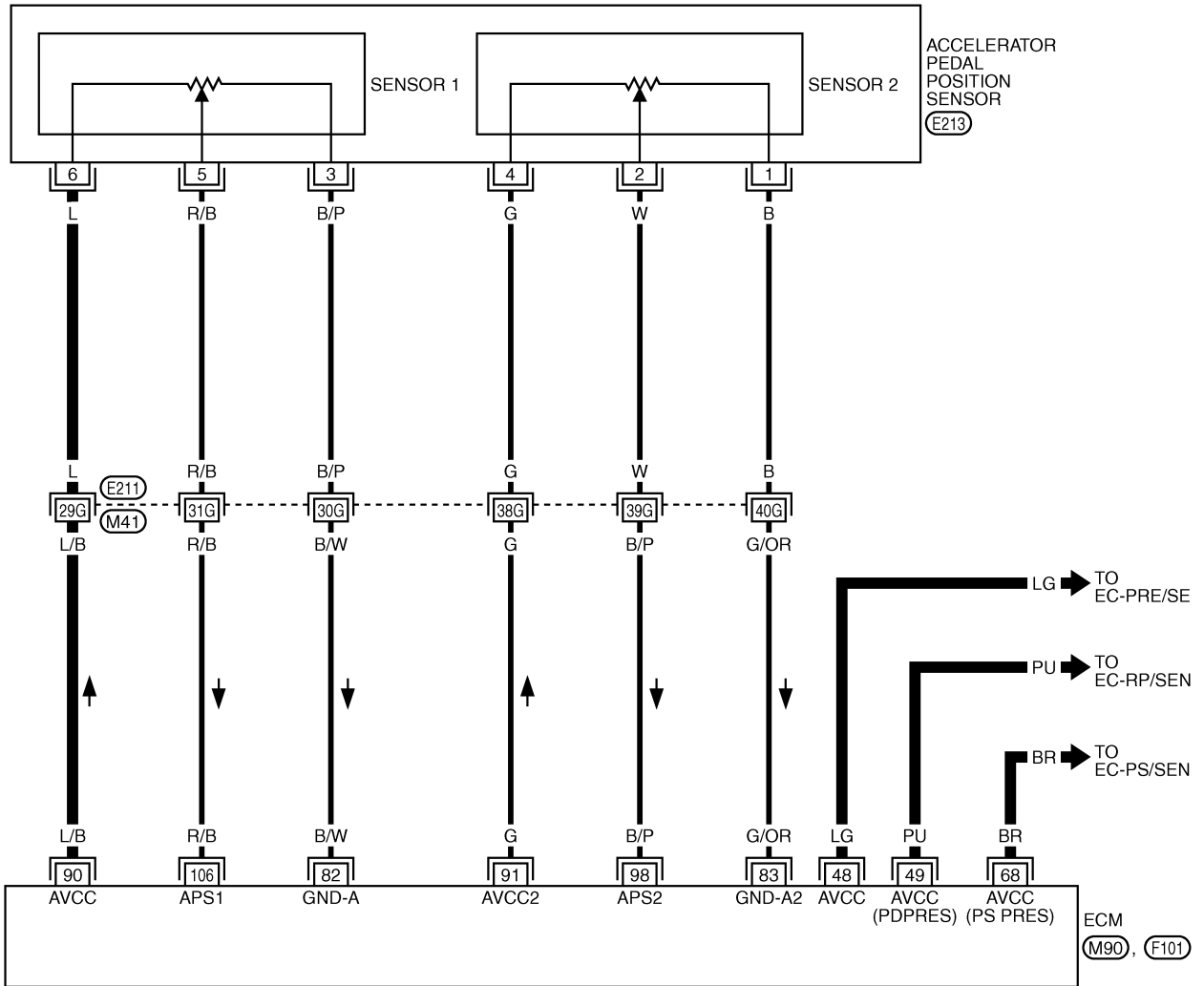

REFER TO THE FOLLOWING.
 (E213) -SUPER MULTIPLE JUNCTION (SMJ)

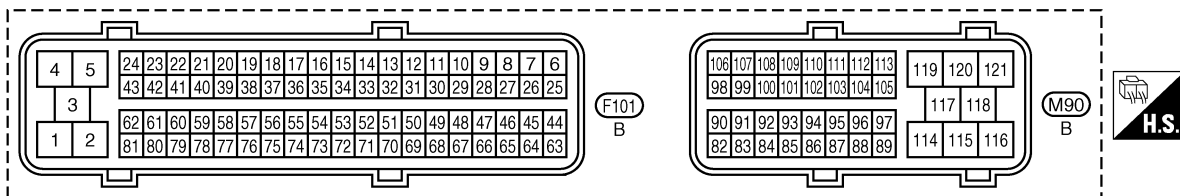

TBWM0402E

DTC P1229 SENSOR POWER SUPPLY

[VQ35DE]

Specification data are reference values and are measured between each terminal and ground.

CAUTION:

Do not use ECM ground terminals when measuring input/output voltage. Doing so may result in damage to the ECM's transistor. Use a ground other than ECM terminals, such as the ground.

TER-MINAL NO.	WIRE COLOR	ITEM	CONDITION	DATA (DC Voltage)
49	PU	Sensor power supply (Refrigerant pressure sensor)	[Ignition switch: ON]	Approximately 5V
68	BR	Sensor power supply (Power steering pressure sensor)	[Ignition switch: ON]	Approximately 5V
90	L/B	Sensor power supply (APP sensor 1)	[Ignition switch: ON]	Approximately 5V
48	LG	Sensor power supply (EVAP control system pressure sensor)	[Ignition switch: ON]	Approximately 5V

Diagnostic Procedure

ABS00CHS

1. CHECK GROUND CONNECTIONS

1. Turn ignition switch OFF.
2. Loosen and retighten ground three screws on the body. Refer to [EC-141, "Ground Inspection"](#).

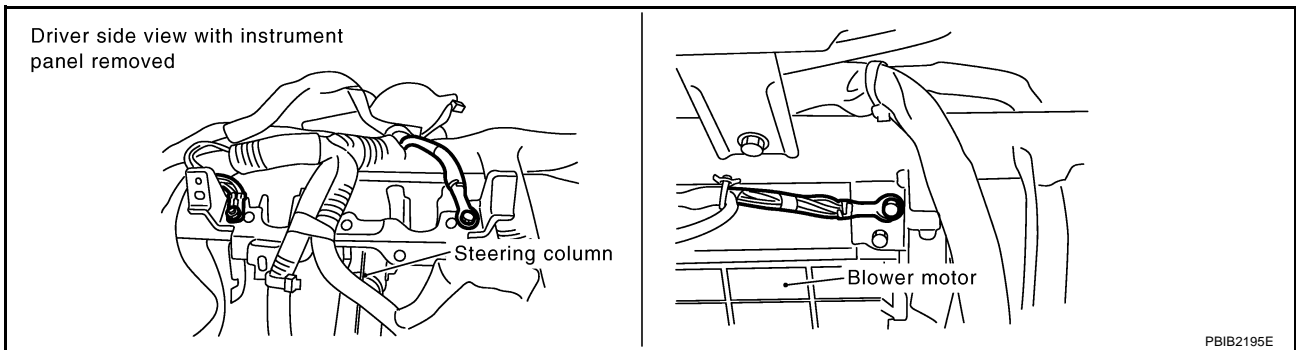

OK or NG

- OK >> GO TO 2.
- NG >> Repair or replace ground connections.

2. CHECK ACCELERATOR PEDAL POSITION SENSOR 1 POWER SUPPLY CIRCUIT

1. Disconnect accelerator pedal position (APP) sensor harness connector.
2. Turn ignition switch ON.

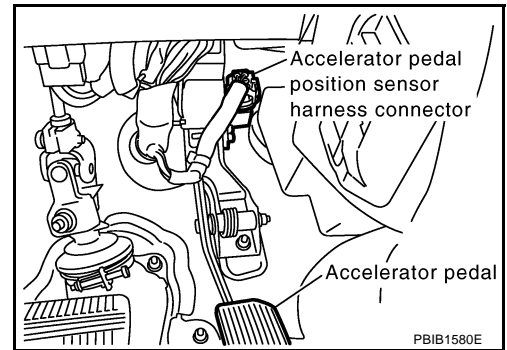

3. Check voltage between APP sensor terminal 6 and ground with CONSULT-II or tester.

Voltage: Approximately 5V

OK or NG

- OK >> GO TO 5.
 NG >> GO TO 3.

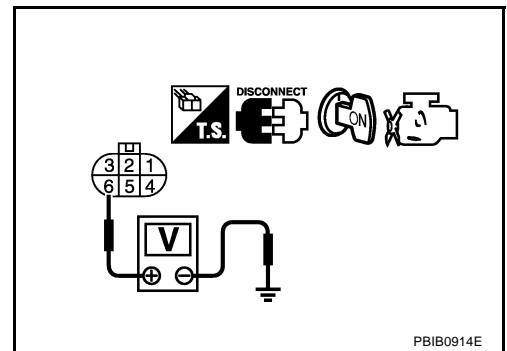

3. CHECK SENSOR POWER SUPPLY CIRCUITS

Check the following.

- Harness for short to power and short to ground, between the following terminals.

ECM terminal	Sensor terminal	Reference Wiring Diagram
90	APP sensor terminal 6	EC-557
49	Refrigerant pressure sensor terminal 1	EC-610
91	PSP sensor terminal 1	EC-397
48	EVAP control system pressure sensor terminal 3	EC-354

- ECM pin terminal.

OK or NG

- OK >> GO TO 4.
 NG >> Repair short to ground or short to power in harness or connectors.

4. CHECK COMPONENTS

Check the following.

- Refrigerant pressure sensor (Refer to [ATC-90, "COMPONENT INSPECTION"](#) .)
- Power steering pressure sensor (Refer to [EC-400, "Component Inspection"](#) .)
- EVAP control system pressure sensor (Refer to [EC-351, "Component Inspection"](#) .)

OK or NG

- OK >> GO TO 7.
 NG >> Replace malfunctioning component.

5. CHECK APP SENSOR

A

Refer to [EC-560, "Component Inspection"](#) .

OK or NG

- OK >> GO TO 7.
- NG >> GO TO 6.

EC

6. REPLACE ACCELERATOR PEDAL ASSEMBLY

C

1. Replace accelerator pedal assembly.
2. Perform [EC-49, "Accelerator Pedal Released Position Learning"](#) .
3. Perform [EC-49, "Throttle Valve Closed Position Learning"](#) .
4. Perform [EC-49, "Idle Air Volume Learning"](#) .

D

E

>> INSPECTION END

7. CHECK INTERMITTENT INCIDENT

F

Refer to [EC-135, "TROUBLE DIAGNOSIS FOR INTERMITTENT INCIDENT"](#) .

G

>> INSPECTION END

H

I

J

K

L

M

DTC P1444 EVAP CANISTER PURGE VOLUME CONTROL SOLENOID VALVE [VQ35DE]

DTC P1444 EVAP CANISTER PURGE VOLUME CONTROL SOLENOID VALVE

PFP:14920

Description SYSTEM DESCRIPTION

ABS006VU

Sensor	Input Signal to ECM	ECM function	Actuator
Crankshaft position sensor (POS) Camshaft position sensor (PHASE)	Engine speed*1	EVAP canister purge flow control	EVAP canister purge vol- ume control solenoid valve
Mass air flow sensor	Amount of intake air		
Engine coolant temperature sensor	Engine coolant temperature		
Battery	Battery voltage*1		
Throttle position sensor	Throttle position		
Accelerator pedal position sensor	Accelerator pedal position		
Heated oxygen sensor 1	Density of oxygen in exhaust gas (Mixture ratio feedback signal)		
Fuel tank temperature sensor	Fuel temperature in fuel tank		
Wheel sensor*2	Vehicle speed		

*1:ECM determines the start signal status by the signals of engine speed and battery voltage.

*2: This signal is sent to the ECM through CAN communication line.

This system controls flow rate of fuel vapor from the EVAP canister. The opening of the vapor by-pass passage in the EVAP canister purge volume control solenoid valve changes to control the flow rate. The EVAP canister purge volume control solenoid valve repeats ON/OFF operation according to the signal sent from the ECM. The opening of the valve varies for optimum engine control. The optimum value stored in the ECM is determined by considering various engine conditions. When the engine is operating, the flow rate of fuel vapor from the EVAP canister is regulated as the air flow changes.

COMPONENT DESCRIPTION

The EVAP canister purge volume control solenoid valve uses a ON/OFF duty to control the flow rate of fuel vapor from the EVAP canister. The EVAP canister purge volume control solenoid valve is moved by ON/OFF pulses from the ECM. The longer the ON pulse, the greater the amount of fuel vapor that will flow through the valve.

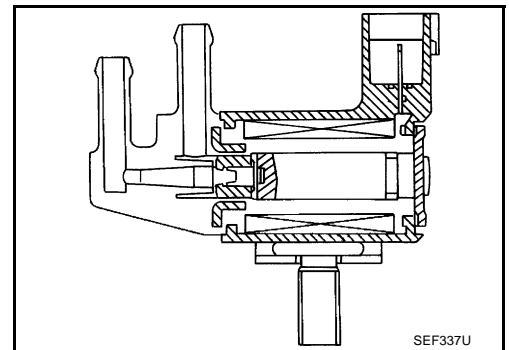

CONSULT-II Reference Value in Data Monitor Mode

ABS006VU

Specification data are reference values.

MONITOR ITEM	CONDITION		SPECIFICATION
PURG VOL C/V	<ul style="list-style-type: none"> ● Engine: After warming up ● Shift lever: P or N ● Air conditioner switch: OFF ● No-load 	Idle	0%
		2,000 rpm	—

DTC P1444 EVAP CANISTER PURGE VOLUME CONTROL SOLENOID VALVE [VQ35DE]

ABS006VW

On Board Diagnosis Logic

DTC No.	Trouble diagnosis name	DTC detecting condition	Possible cause
P1444 1444	EVAP canister purge volume control solenoid valve	The canister purge flow is detected during the specified driving conditions, even when EVAP canister purge volume control solenoid valve is completely closed.	<ul style="list-style-type: none"> ● EVAP control system pressure sensor ● EVAP canister purge volume control solenoid valve (The valve is stuck open.) ● EVAP canister vent control valve ● EVAP canister ● Hoses (Hoses are connected incorrectly or clogged.)

DTC Confirmation Procedure

ABS006VX

NOTE:

If DTC Confirmation Procedure has been previously conducted, always turn ignition switch OFF and wait at least 10 seconds before conducting the next test.

TESTING CONDITION:

Always perform test at a temperature of 5°C (41°F) or more.

Ⓜ WITH CONSULT-II

1. Start engine and warm it up to normal operating temperature.
2. Turn ignition switch OFF and wait at least 10 seconds.
3. Turn ignition switch ON.
4. Select "PURG VOL CN/V P1444" of "EVAPORATIVE SYSTEM" in "DTC WORK SUPPORT" mode with CONSULT-II.
5. Touch "START".

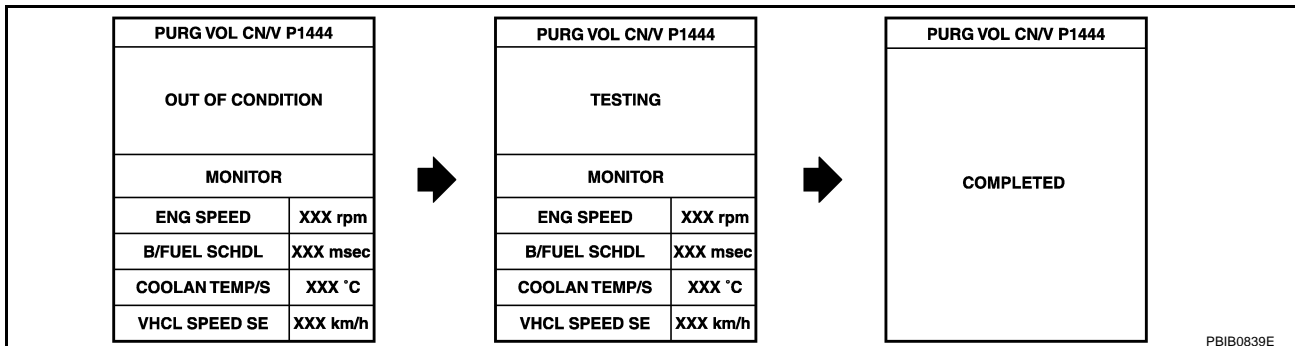

6. Start engine and let it idle until "TESTING" on CONSULT-II changes to "COMPLETED". (It will take approximately 10 seconds.)
If "TESTING" is not displayed after 5 minutes, retry from step 2.
7. Make sure that "OK" is displayed after touching "SELF-DIAG RESULTS". If "NG" is displayed, refer to [EC-498, "Diagnostic Procedure"](#).

Ⓜ WITH GST

1. Start engine and warm it up to normal operating temperature.
2. Turn ignition switch OFF and wait at least 10 seconds.
3. Start engine and let it idle for at least 20 seconds.
4. Select MODE 7 with GST.
5. If 1st trip DTC is detected, go to [EC-498, "Diagnostic Procedure"](#).

DTC P1444 EVAP CANISTER PURGE VOLUME CONTROL SOLENOID VALVE [VQ35DE]

ABS006VY

Wiring Diagram

EC-PGC/V-01

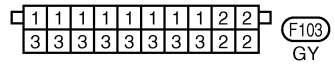
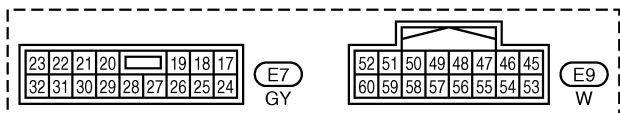
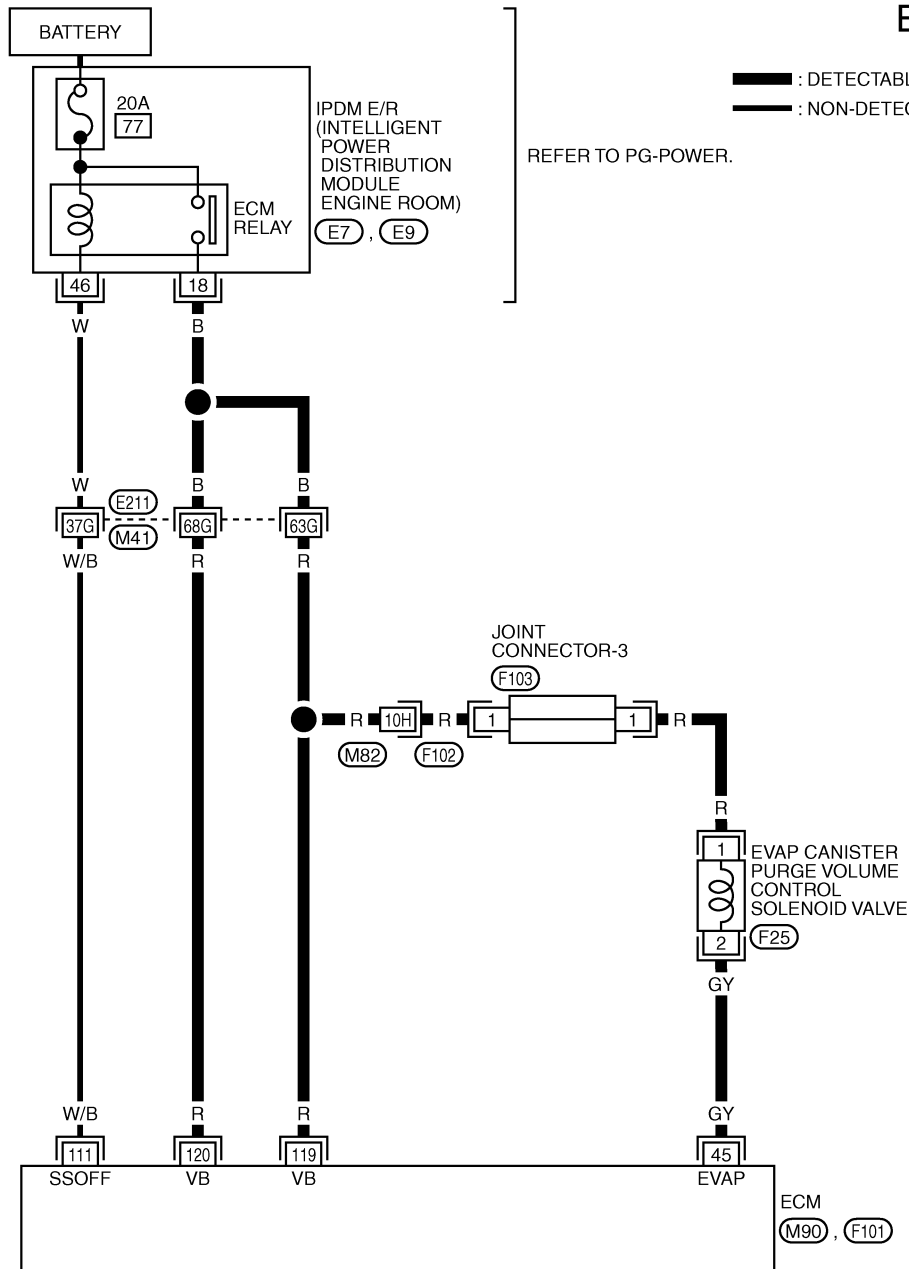

REFER TO THE FOLLOWING.
 (E21), (F102) -SUPER MULTIPLE JUNCTION (SMJ)

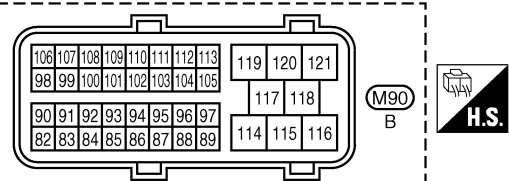
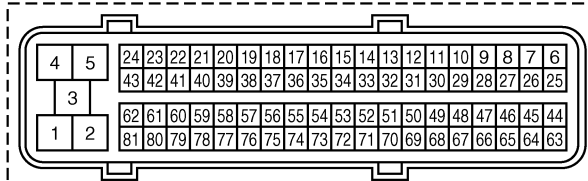

TBWM0300E

DTC P1444 EVAP CANISTER PURGE VOLUME CONTROL SOLENOID VALVE

[VQ35DE]

Specification data are reference values and are measured between each terminal and ground.
Pulse signal is measured by CONSULT-II.

CAUTION:

Do not use ECM ground terminals when measuring input/output voltage. Doing so may result in damage to the ECM's transistor. Use a ground other than ECM terminals, such as the ground.

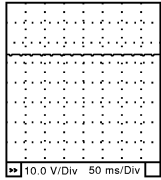
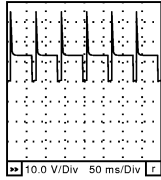
TER-MINAL NO.	WIRE COLOR	ITEM	CONDITION	DATA (DC Voltage)
45	GY	EVAP canister purge volume control solenoid valve	<p>[Engine is running]</p> <ul style="list-style-type: none"> ● Idle speed 	<p>BATTERY VOLTAGE (11 - 14V)★</p> 
			<p>[Engine is running]</p> <ul style="list-style-type: none"> ● Engine speed is about 2,000 rpm (More than 100 seconds after starting engine) 	<p>BATTERY VOLTAGE (11 - 14V)★</p> 
111	W/B	ECM relay (Self shut-off)	<p>[Engine is running] [Ignition switch: OFF]</p> <ul style="list-style-type: none"> ● For a few seconds after turning ignition switch OFF 	0 - 1.5V
			<p>[Ignition switch: OFF]</p> <ul style="list-style-type: none"> ● More than a few seconds after turning ignition switch OFF 	BATTERY VOLTAGE (11 - 14V)
119 120	R R	Power supply for ECM	[Ignition switch: ON]	BATTERY VOLTAGE (11 - 14V)

★: Average voltage for pulse signal (Actual pulse signal can be confirmed by oscilloscope.)

DTC P1444 EVAP CANISTER PURGE VOLUME CONTROL SOLENOID VALVE [VQ35DE]

ABS006VZ

Diagnostic Procedure

1. CHECK EVAP CANISTER PURGE VOLUME CONTROL SOLENOID VALVE POWER SUPPLY CIRCUIT

1. Turn ignition switch OFF.
2. Disconnect EVAP canister purge volume control solenoid valve harness connector.
3. Turn ignition switch ON.

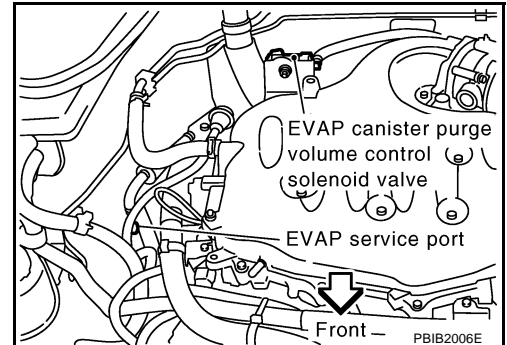

4. Check voltage between EVAP canister purge volume control solenoid valve terminal 1 and ground with CONSULT-II or tester.

Voltage: Battery voltage

OK or NG

- OK >> GO TO 3.
- NG >> GO TO 2.

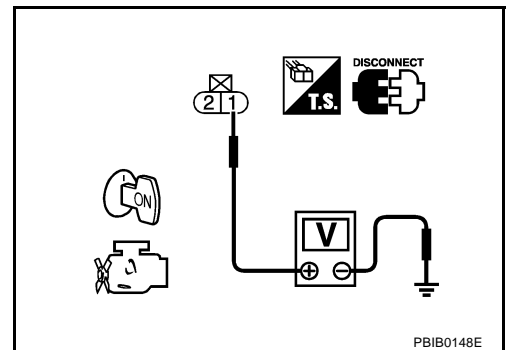

2. DETECT MALFUNCTIONING PART

Check the following.

- Harness connectors E211, M41
- Harness connectors M82, F102
- Joint connector-3
- IPDM E/R harness connector E7
- 20A fuse
- Harness for open or short between EVAP canister purge volume control solenoid valve and IPDM E/R
- Harness for open or short between EVAP canister purge volume control solenoid valve and ECM

>> Repair harness or connectors.

3. CHECK EVAP CANISTER PURGE VOLUME CONTROL SOLENOID VALVE OUTPUT SIGNAL CIRCUIT FOR OPEN AND SHORT

1. Turn ignition switch OFF.
2. Disconnect ECM harness connector.
3. Check harness continuity between ECM terminal 45 and EVAP canister purge volume control solenoid valve terminal 2. Refer to Wiring Diagram.

Continuity should exist.

4. Also check harness for short to ground and short to power.

OK or NG

- OK >> GO TO 4.
- NG >> Repair open circuit or short to ground or short to power in harness or connectors.

DTC P1444 EVAP CANISTER PURGE VOLUME CONTROL SOLENOID VALVE [VQ35DE]

4. CHECK EVAP CONTROL SYSTEM PRESSURE SENSOR CONNECTOR

1. Disconnect EVAP control system pressure sensor harness connector.
2. Check connectors for water.

Water should not exist.

OK or NG

- OK >> GO TO 5.
NG >> Replace EVAP control system pressure sensor.

5. CHECK EVAP CONTROL SYSTEM PRESSURE SENSOR

Refer to [EC-357, "Component Inspection"](#) .

OK or NG

- OK (With CONSULT-II)>>GO TO 6.
OK (Without CONSULT-II)>>GO TO 7.
NG >> Replace EVAP control system pressure sensor.

6. CHECK EVAP CANISTER PURGE VOLUME CONTROL SOLENOID VALVE

 **With CONSULT-II**

1. Turn ignition switch OFF.
2. Reconnect harness connectors disconnected.
3. Start engine.
4. Perform "PURG VOL CONT/V" in "ACTIVE TEST" mode with CONSULT-II. Check that engine speed varies according to the valve opening.

OK or NG

- OK >> GO TO 8.
NG >> GO TO 7.

ACTIVE TEST	
PURG VOL CONT/V	0 %
MONITOR	
ENG SPEED	XXX rpm
HO2S1 MNTR (B1)	LEAN
HO2S1 MNTR (B2)	LEAN
A/F ALPHA-B1	XXX %
A/F ALPHA-B2	XXX %

PBIB0147E

7. CHECK EVAP CANISTER PURGE VOLUME CONTROL SOLENOID VALVE

Refer to [EC-501, "Component Inspection"](#) .

OK or NG

- OK >> GO TO 8.
NG >> Replace EVAP canister purge volume control solenoid valve.

8. CHECK RUBBER TUBE FOR CLOGGING

1. Disconnect rubber tube connected to EVAP canister vent control valve.
2. Check the rubber tube for clogging.

OK or NG

- OK >> GO TO 9.
NG >> Clean the rubber tube using an air blower.

9. CHECK EVAP CANISTER VENT CONTROL VALVE

Refer to [EC-347, "Component Inspection"](#) .

OK or NG

- OK >> GO TO 10.
NG >> Replace EVAP canister vent control valve.

DTC P1444 EVAP CANISTER PURGE VOLUME CONTROL SOLENOID VALVE [VQ35DE]

10. CHECK IF EVAP CANISTER SATURATED WITH WATER

1. Remove EVAP canister with EVAP canister vent control valve and EVAP control system pressure sensor attached.
2. Check if water will drain from the EVAP canister.

Yes or No

Yes >> GO TO 11.

No >> GO TO 13.

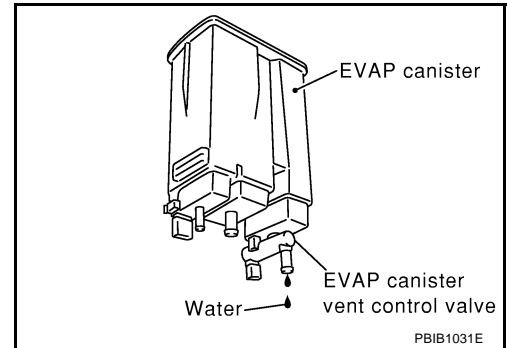

11. CHECK EVAP CANISTER

Weigh the EVAP canister with the EVAP canister vent control valve and EVAP control system pressure sensor attached.

The weight should be less than 2.1 kg (4.6 lb).

OK or NG

OK >> GO TO 13.

NG >> GO TO 12.

12. DETECT MALFUNCTIONING PART

Check the following.

- EVAP canister for damage
- EVAP hose between EVAP canister and vehicle frame for clogging or poor connection

>> Repair hose or replace EVAP canister.

13. CHECK INTERMITTENT INCIDENT

Refer to [EC-135, "TROUBLE DIAGNOSIS FOR INTERMITTENT INCIDENT"](#) .

>> **INSPECTION END**

DTC P1444 EVAP CANISTER PURGE VOLUME CONTROL SOLENOID VALVE [VQ35DE]

ABS006W0

Component Inspection

EVAP CANISTER PURGE VOLUME CONTROL SOLENOID VALVE

With CONSULT-II

Check air passage continuity of EVAP canister purge volume control solenoid valve under the following conditions.

Condition (PURG VOL CONT/V value)	Air passage continuity between A and B
100%	Yes
0%	No

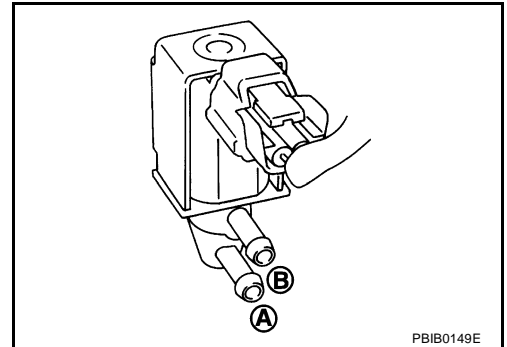

Without CONSULT-II

Check air passage continuity of EVAP canister purge volume control solenoid valve under the following conditions.

Condition	Air passage continuity between A and B
12V direct current supply between terminals 1 and 2	Yes
No supply	No

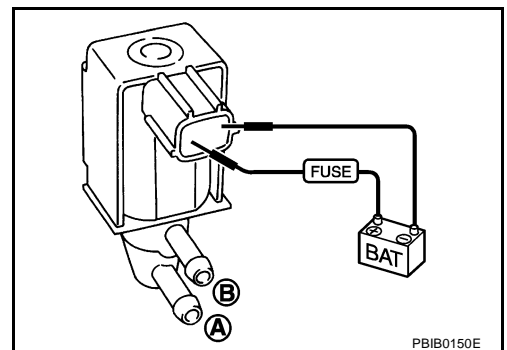

Removal and Installation

EVAP CANISTER PURGE VOLUME CONTROL SOLENOID VALVE

Refer to [EM-19, "INTAKE MANIFOLD COLLECTOR"](#).

ABS006W1

A
EC
C
D
E
F
G
H
I
J
K
L
M

DTC P1446 EVAP CANISTER VENT CONTROL VALVE

PFP:14935

Component Description

ABS006W2

The EVAP canister vent control valve is located on the EVAP canister and is used to seal the canister vent.

This solenoid valve responds to signals from the ECM. When the ECM sends an ON signal, the coil in the solenoid valve is energized. A plunger will then move to seal the canister vent. The ability to seal the vent is necessary for the on board diagnosis of other evaporative emission control system components.

This solenoid valve is used only for diagnosis, and usually remains opened.

When the vent is closed, under normal purge conditions, the evaporative emission control system is depressurized and allows EVAP Control System diagnosis.

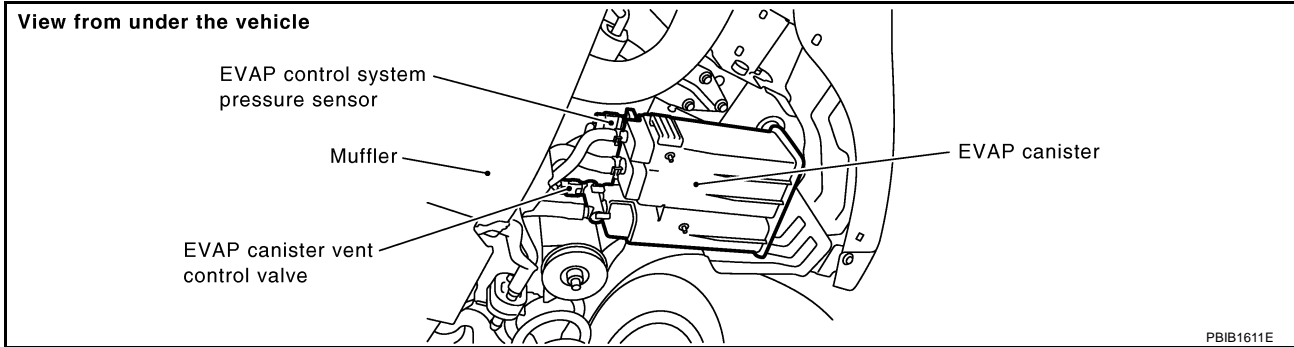
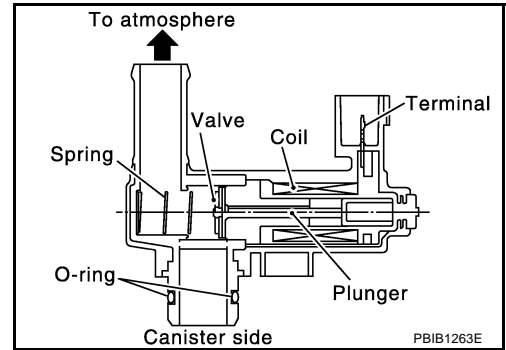

CONSULT-II Reference Value in Data Monitor Mode

ABS006W3

Specification data are reference values.

MONITOR ITEM	CONDITION	SPECIFICATION
VENT CONT/V	● Ignition switch: ON	OFF

On Board Diagnosis Logic

ABS006W4

DTC No.	Trouble diagnosis name	DTC detecting condition	Possible cause
P1446 1446	EVAP canister vent control valve close	EVAP canister vent control valve remains closed under specified driving conditions.	<ul style="list-style-type: none"> ● EVAP canister vent control valve ● EVAP control system pressure sensor and the circuit ● Blocked rubber tube to EVAP canister vent control valve ● EVAP canister is saturated with water

DTC Confirmation Procedure

NOTE:

If DTC Confirmation Procedure has been previously conducted, always turn ignition switch OFF and wait at least 10 seconds before conducting the next test.

Ⓟ WITH CONSULT-II

1. Turn ignition switch ON and wait at least 5 seconds.
2. Turn ignition switch OFF and wait at least 10 seconds.
3. Turn ignition switch ON and select "DATA MONITOR" mode with CONSULT-II.
4. Start engine and let it idle for at least 1 minute.
5. Repeat next procedures 3 times.
 - a. Increase the engine speed up to 3,000 to 3,500 rpm and keep it for 2 minutes and 50 seconds to 3 minutes.
Never exceed 3 minutes.
 - b. Fully released accelerator pedal and keep engine idle for about 5 seconds.
6. If 1st trip DTC is detected, go to [EC-505, "Diagnostic Procedure"](#)

DATA MONITOR	
MONITOR	NO DTC
ENG SPEED	XXX rpm

SEF058Y

If 1st trip DTC is not detected, go to the next step.

7. Repeat next procedure 20 times.
 - a. Quickly increase the engine speed up to 4,000 to 4,500 rpm or more and keep it for 25 to 30 seconds.
 - b. Fully released accelerator pedal and keep engine idle for at least 35 seconds.

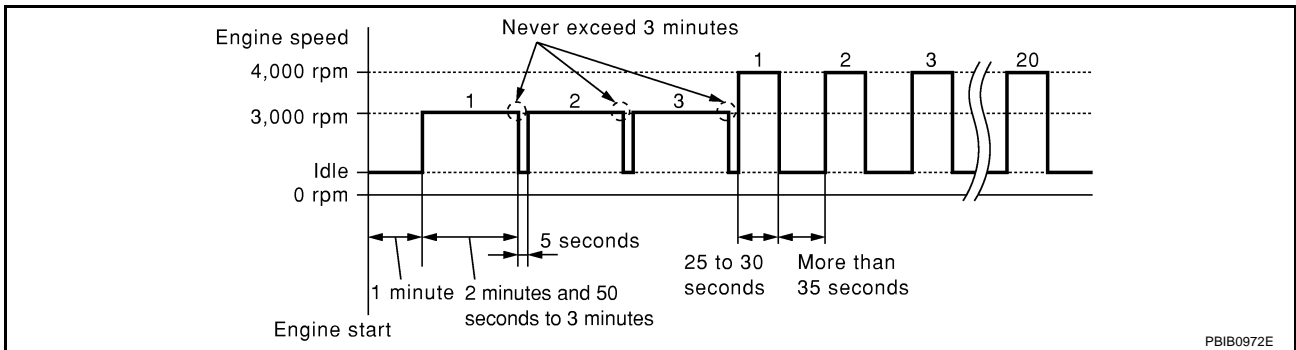

8. If 1st trip DTC is detected, go to [EC-505, "Diagnostic Procedure"](#) .

Ⓢ WITH GST

Follow the procedure "WITH CONSULT-II" above.

DTC P1446 EVAP CANISTER VENT CONTROL VALVE

[VQ35DE]

ABS006W6

Wiring Diagram

EC-VENT/V-01

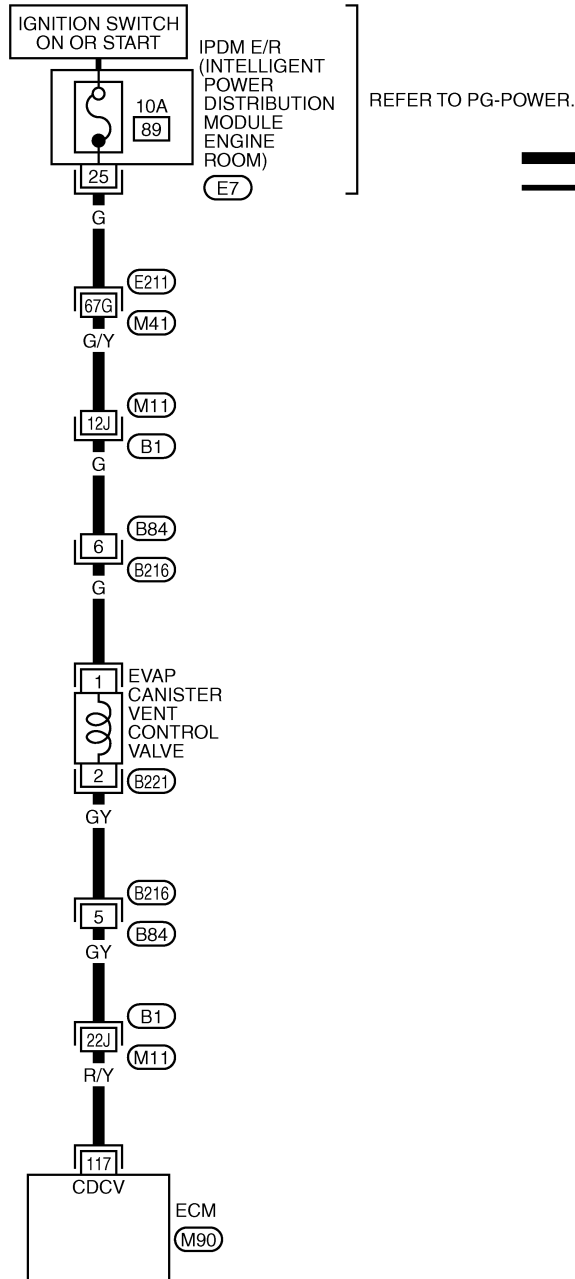

REFER TO PG-POWER.
— : DETECTABLE LINE FOR DTC
— : NON-DETECTABLE LINE FOR DTC

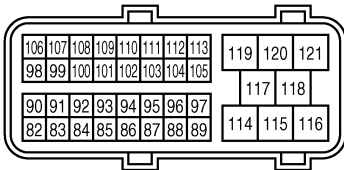

(M90)
B

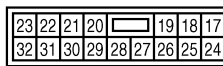

(E7)
GY



(B216)
GY

(B221)
B

REFER TO THE FOLLOWING.

(E211), (B1) -SUPER MULTIPLE JUNCTION (SMJ)

TBWH0110E

DTC P1446 EVAP CANISTER VENT CONTROL VALVE

[VQ35DE]

Specification data are reference values and are measured between each terminal and ground.

CAUTION:

Do not use ECM ground terminals when measuring input/output voltage. Doing so may result in damage to the ECM's transistor. Use a ground other than ECM terminals, such as the ground.

TER-MINAL NO.	WIRE COLOR	ITEM	CONDITION	DATA (DC Voltage)
117	R/Y	EVAP canister vent control valve	[Ignition switch: ON]	BATTERY VOLTAGE (11 - 14V)

Diagnostic Procedure

ABS006W7

1. CHECK RUBBER TUBE

1. Turn ignition switch OFF.
2. Disconnect rubber tube connected to EVAP canister vent control valve.

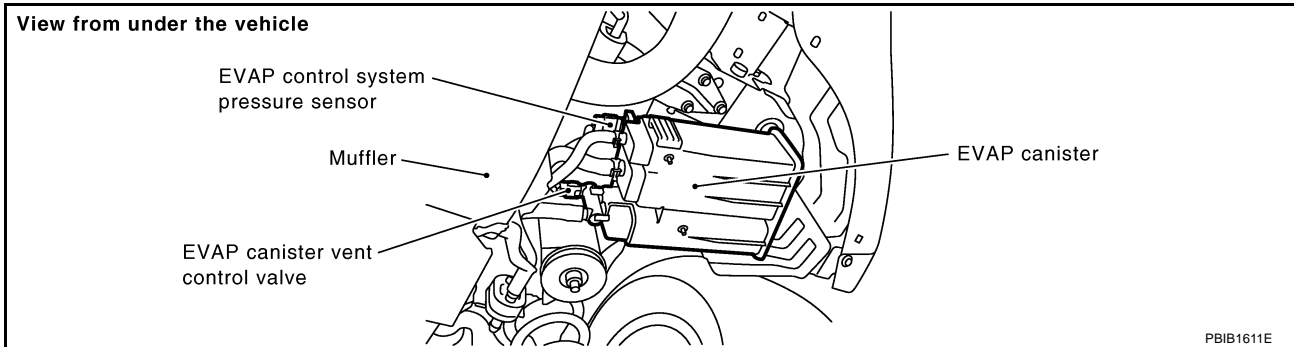

3. Check the rubber tube for clogging.

OK or NG

- OK >> GO TO 2.
- NG >> Clean rubber tube using an air blower.

2. CHECK EVAP CANISTER VENT CONTROL VALVE

Refer to [EC-347, "Component Inspection"](#).

OK or NG

- OK >> GO TO 3.
- NG >> Replace EVAP canister vent control valve.

3. CHECK IF EVAP CANISTER SATURATED WITH WATER

1. Remove EVAP canister with EVAP canister vent control valve and EVAP control system pressure sensor attached.
2. Check if water will drain from the EVAP canister.

Yes or No

- Yes >> GO TO 4.
- No >> GO TO 6.

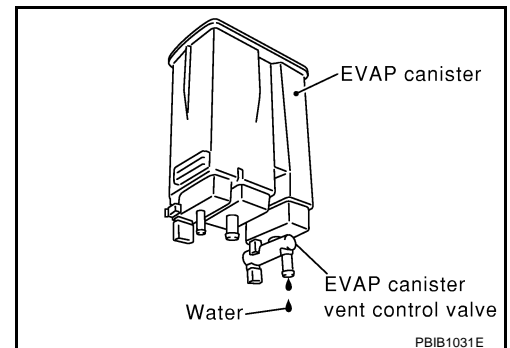

4. CHECK EVAP CANISTER

Weigh the EVAP canister with the EVAP canister vent control valve and EVAP control system pressure sensor attached.

The weight should be less than 2.1 kg (4.6 lb).

OK or NG

- OK >> GO TO 6.
- NG >> GO TO 5.

5. DETECT MALFUNCTIONING PART

Check the following.

- EVAP canister for damage
- EVAP hose between EVAP canister and vehicle frame for clogging or poor connection

>> Repair hose or replace EVAP canister.

6. CHECK EVAP CONTROL SYSTEM PRESSURE SENSOR CONNECTOR

1. Disconnect EVAP control system pressure sensor harness connector.
2. Check connectors for water.

Water should not exist.

OK or NG

- OK >> GO TO 7.
- NG >> Replace EVAP control system pressure sensor.

7. CHECK EVAP CONTROL SYSTEM PRESSURE SENSOR

Refer to [EC-357, "Component Inspection"](#) .

OK or NG

- OK >> GO TO 8.
- NG >> Replace EVAP control system pressure sensor.

8. CHECK INTERMITTENT INCIDENT

Refer to [EC-135, "TROUBLE DIAGNOSIS FOR INTERMITTENT INCIDENT"](#) .

>> INSPECTION END

Component Inspection EVAP CANISTER VENT CONTROL VALVE

ABS006W8

④ **With CONSULT-II**

1. Remove EVAP canister vent control valve from EVAP canister.
2. Check portion **B** of EVAP canister vent control valve for being rusted.
If NG, replace EVAP canister vent control valve.
If OK, go to next step.
3. Reconnect harness connectors disconnected.
4. Turn ignition switch ON.

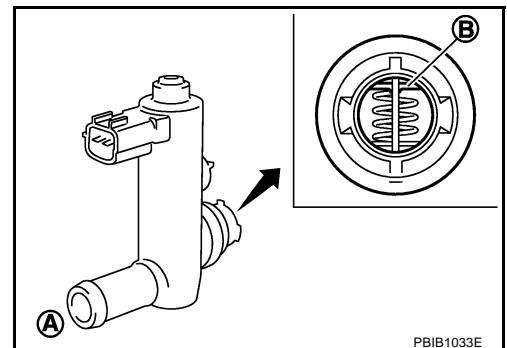

DTC P1446 EVAP CANISTER VENT CONTROL VALVE

[VQ35DE]

5. Perform "VENT CONTROL/V" in "ACTIVE TEST" mode.
6. Check air passage continuity and operation delay time.
Make sure new O-ring is installed properly.

Condition VENT CONTROL/V	Air passage continuity between A and B
ON	No
OFF	Yes

Operation takes less than 1 second.

If NG, replace EVAP canister vent control valve.
If OK, go to next step.

7. Clean the air passage (Portion **A** to **B**) of EVAP canister vent control valve using an air blower.
8. Perform step 6 again.

ACTIVE TEST	
VENT CONTROL/V	OFF
MONITOR	
ENG SPEED	XXX rpm
A/F ALPHA-B1	XXX %
A/F ALPHA-B2	XXX %
HO2S1 (B1)	XXX V
HO2S1 (B2)	XXX V

PBIB0151E

⊗ **Without CONSULT-II**

1. Remove EVAP canister vent control valve from EVAP canister.
2. Check portion **B** of EVAP canister vent control valve for being rusted.

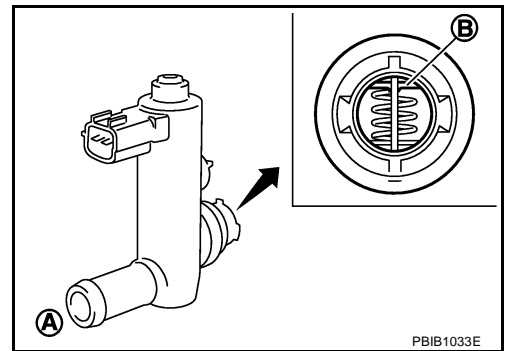

3. Check air passage continuity and operation delay time under the following conditions.
Make sure new O-ring is installed properly.

Condition	Air passage continuity between A and B
12V direct current supply between terminals 1 and 2	No
OFF	Yes

Operation takes less than 1 second.

If NG, replace EVAP canister vent control valve.
If OK, go to next step.

4. Clean the air passage (Portion **A** to **B**) of EVAP canister vent control valve using an air blower.
5. Perform step 3 again.

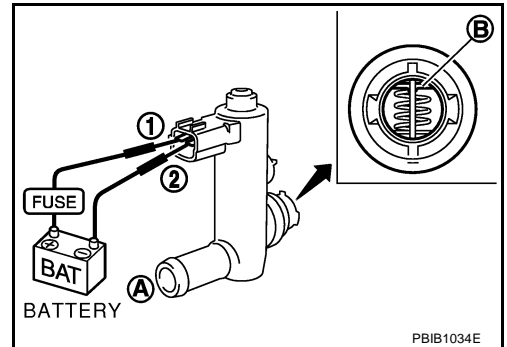

DTC P1564 ICC STEERING SWITCH

PFP:25551

Component Description

ABS007YZ

ICC steering switch has variant values of electrical resistance for each button. ECM reads voltage variation of switch, and determines which button is operated.

Refer to [ACS-6, "DESCRIPTION"](#) for the ICC function.

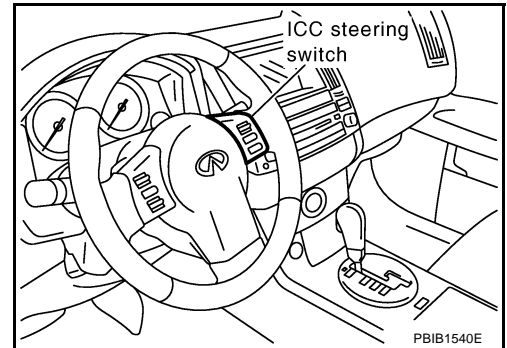

CONSULT-II Reference Value in Data Monitor Mode

ABS007Z0

Specification data are reference values.

MONITOR ITEM	CONDITION		SPECIFICATION
MAIN SW	● Ignition switch: ON	● ON/OFF(MAIN) switch: Pressed	ON
		● ON/OFF(MAIN) switch: Released	OFF
CANCEL SW	● Ignition switch: ON	● CANCEL switch: Pressed	ON
		● CANCEL switch: Released	OFF
RESUME/ACC SW	● Ignition switch: ON	● ACCEL/ RESUME switch: Pressed	ON
		● ACCEL/ RESUME switch: Released	OFF
SET SW	● Ignition switch: ON	● COAST/SET switch: Pressed	ON
		● COAST/SET switch: Released	OFF
DIST SW	● Ignition switch: ON	● DISTANCE switch: Pressed	ON
		● DISTANCE switch: Released	OFF

On Board Diagnosis Logic

ABS007Z1

- This self-diagnosis has the one trip detection logic.
- The MIL will not light up for this self-diagnosis.

NOTE:

If DTC P1564 is displayed with DTC P0605, first perform the trouble diagnosis for DTC P0605. Refer to [EC-401](#).

DTC No.	Trouble Diagnosis Name	DTC Detecting Condition	Possible Cause
P1564 1564	ICC steering switch	<ul style="list-style-type: none"> ● An excessively high voltage signal from the ICC steering switch is sent to ECM. ● ECM detects that input signal from the ICC steering switch is out of the specified range. ● ECM detects that the ICC steering switch is stuck ON. 	<ul style="list-style-type: none"> ● Harness or connectors (The switch circuit is open or shorted.) ● ICC steering switch ● ECM

DTC Confirmation Procedure

ABS007Z2

NOTE:

If DTC Confirmation Procedure has been previously conducted, always turn ignition switch OFF and wait at least 10 seconds before conducting the next test.

WITH CONSULT-II

1. Turn ignition switch ON.
2. Select "DATA MONITOR" mode with CONSULT-II.
3. Wait at least 10 seconds.
4. Press ON/OFF(MAIN) switch for at least 10 seconds, then release it and wait at least 10 seconds.
5. Press ACCEL/RESUME switch for at least 10 seconds, then release it and wait at least 10 seconds.
6. Press COAST/SET switch for at least 10 seconds, then release it and wait at least 10 seconds.
7. Press DISTANCE switch for at least 10 seconds, then release it and wait at least 10 seconds.
8. Press CANCEL switch for at least 10 seconds, then release it and wait at least 10 seconds.
9. If DTC is detected, go to [EC-511, "Diagnostic Procedure"](#) .

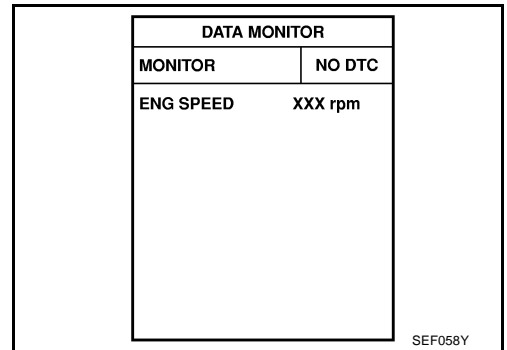

WITH GST

Follow the procedure "WITH CONSULT-II" above.

A
EC
C
D
E
F
G
H
I
J
K
L
M

DTC P1564 ICC STEERING SWITCH

[VQ35DE]

Wiring Diagram

ABS007Z3

EC-ICC/SW-01

: DETECTABLE LINE FOR DTC
 : NON-DETECTABLE LINE FOR DTC

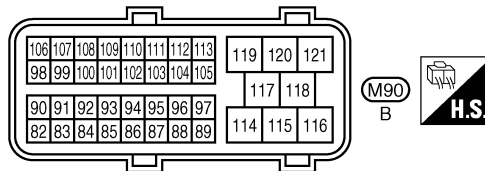
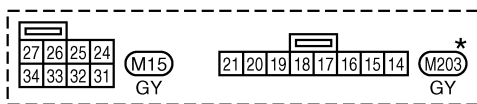
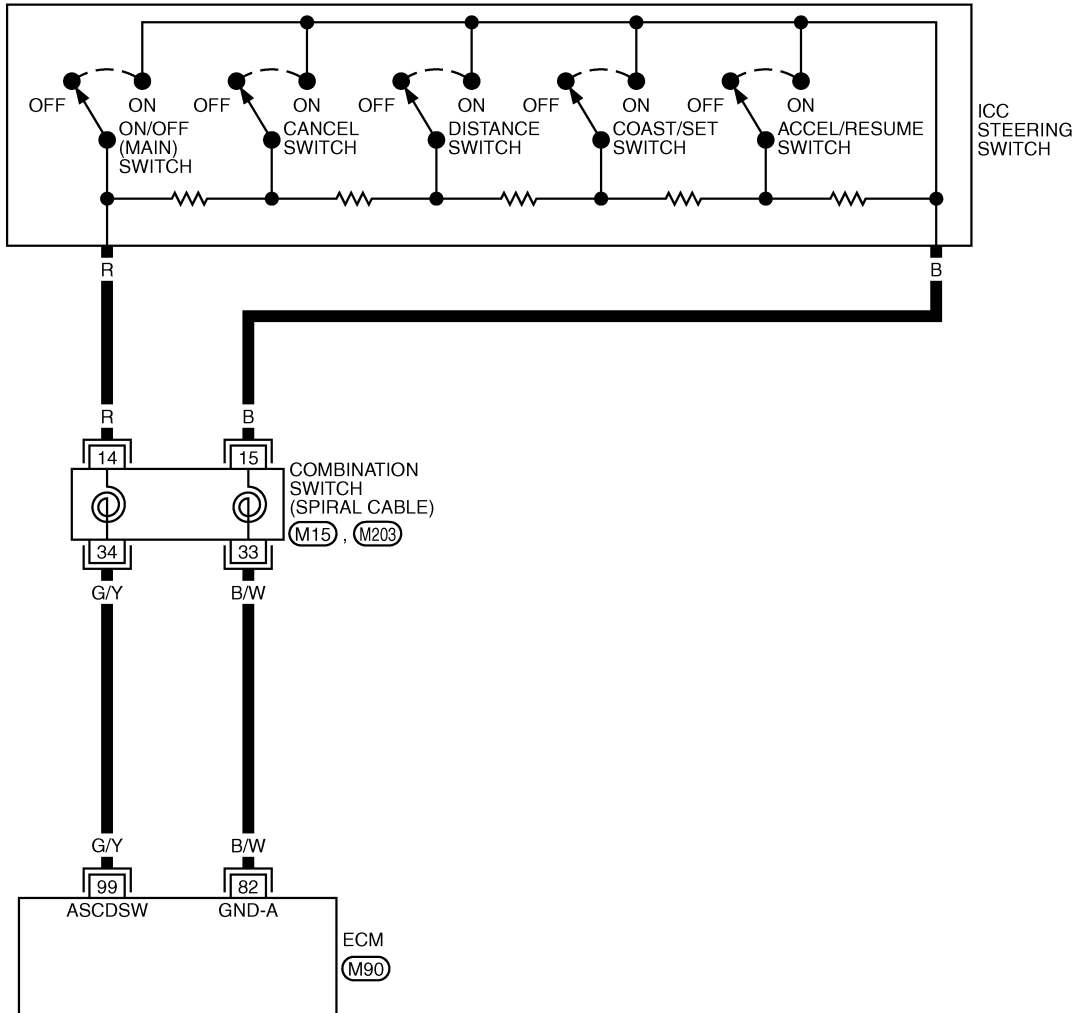

*: THIS CONNECTOR IS NOT SHOWN IN "HARNESS LAYOUT", PG SECTION.

TBWM0273E

DTC P1564 ICC STEERING SWITCH

[VQ35DE]

Specification data are reference values and are measured between each terminal and ground.

CAUTION:

Do not use ECM ground terminals when measuring input/output voltage. Doing so may result in damage to the ECM's transistor. Use a ground other than ECM terminals, such as the ground.

TERMI- NAL NO.	WIRE COLOR	ITEM	CONDITION	DATA (DC Voltage)
82	B/W	Sensor ground (ICC steering switch)	[Engine is running] ● Warm-up condition ● Idle speed	Approximately 0V
99	G/Y	ICC steering switch	[Ignition switch: ON] ● ICC steering switch: OFF	Approximately 4.3V
			[Ignition switch: ON] ● ON/OFF(MAIN) switch: Pressed	Approximately 0V
			[Ignition switch: ON] ● CANCEL switch: Pressed	Approximately 1.3V
			[Ignition switch: ON] ● DISTANCE switch: Pressed	Approximately 2.2V
			[Ignition switch: ON] ● COAST/SET switch: Pressed	Approximately 3V
			[Ignition switch: ON] ● ACCEL/RESUME switch: Pressed	Approximately 3.7V

Diagnostic Procedure

ABS007Z4

1. CHECK GROUND CONNECTIONS

1. Turn ignition switch OFF.
2. Loosen and retighten ground three screws on the body. Refer to [EC-141, "Ground Inspection"](#).

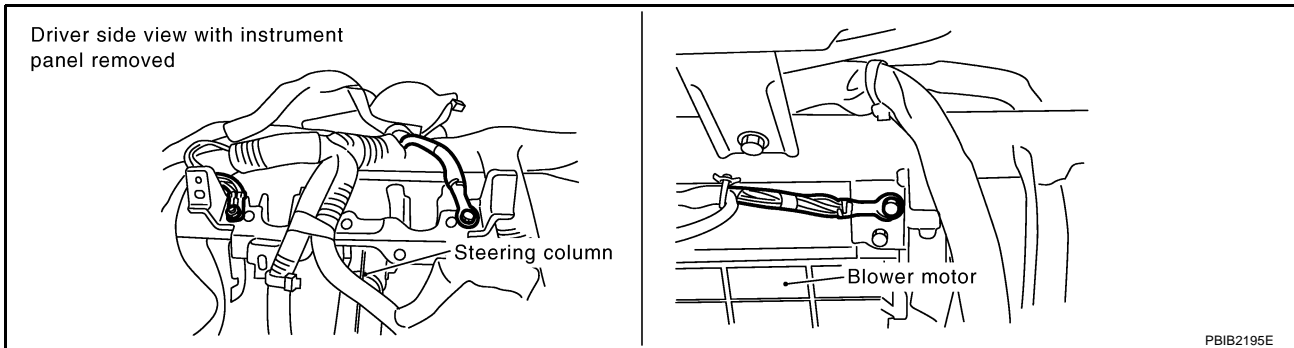

OK or NG

- OK >> GO TO 2.
- NG >> Repair or replace ground connections.

2. CHECK ICC STEERING SWITCH CIRCUIT

④ With CONSULT-II

1. Turn ignition switch ON.
2. Select "MAIN SW", "RESUME/ACC SW", "SET SW", "DIST SW" and "CANCEL SW" in "DATA MONITOR" mode with CONSULT-II.
3. Check each item indication under the following conditions.

DATA MONITOR	
MONITOR	NO DTC
MAIN SW	OFF
CANCEL SW	OFF
RESUME/ACC SW	OFF
SET SW	OFF
DIST SW	OFF

MBIB0064E

Switch	Monitor item	Condition	Indication
ON/OFF(MAIN) switch	MAIN SW	Pressed	ON
		Released	OFF
COAST/SET switch	SET SW	Pressed	ON
		Released	OFF
ACCEL/RESUME switch	RESUME/ACC SW	Pressed	ON
		Released	OFF
DISTANCE switch	DIST SW	Pressed	ON
		Released	OFF
CANCEL switch	CANCEL SW	Pressed	ON
		Released	OFF

⊗ Without CONSULT-II

1. Turn ignition switch ON.
2. Check voltage between ECM terminal 99 and ground with pressing each button.

Switch	Condition	Voltage [V]
ON/OFF(MAIN) switch	Pressed	Approx. 0
	Released	Approx. 4.3
COAST/SET switch	Pressed	Approx. 3.0
	Released	Approx. 4.3
ACCEL/ RESUME switch	Pressed	Approx. 3.7
	Released	Approx. 4.3
DISTANCE switch	Pressed	Approx. 2.2
	Released	Approx. 4.3
CANCEL switch	Pressed	Approx. 1.3
	Released	Approx. 4.3

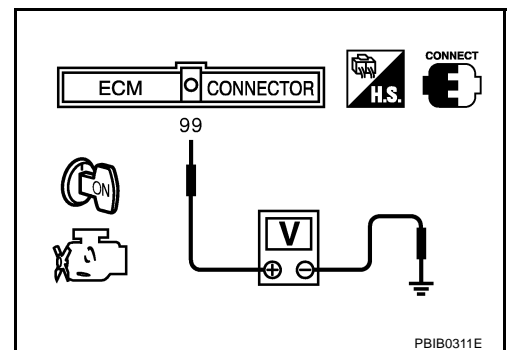

OK or NG

- OK >> GO TO 8.
 NG >> GO TO 3.

3. CHECK ICC STEERING SWITCH GROUND CIRCUIT FOR OPEN AND SHORT

1. Turn ignition switch OFF.
2. Disconnect combination switch harness connector.
3. Disconnect ECM harness connector.
4. Check harness continuity between combination switch terminal 15 and ECM terminal 82.
Refer to Wiring Diagram.

Continuity should exist.

5. Also check harness for short to ground and short to power.

OK or NG

OK >> GO TO 5.

NG >> GO TO 4.

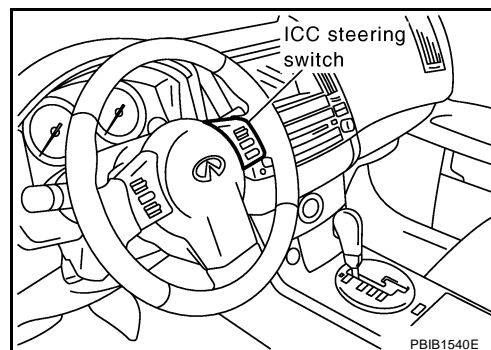

4. DETECT MALFUNCTIONING PART

Check the following.

- Combination switch (spiral cable)
- Harness for open and short between ECM and combination switch

>> Repair open circuit or short to ground or short to power in harness or connectors.

5. CHECK ICC STEERING SWITCH INPUT SIGNAL CIRCUIT FOR OPEN AND SHORT

1. Check harness continuity between ECM terminal 99 and combination switch terminal 14.
Refer to Wiring Diagram.

Continuity should exist.

2. Also check harness for short to ground and short to power.

OK or NG

OK >> GO TO 7.

NG >> GO TO 6.

6. DETECT MALFUNCTIONING PART

Check the following.

- Combination switch (spiral cable)
- Harness for open and short between ECM and combination switch

>> Repair open circuit or short to ground or short to power in harness or connectors.

7. CHECK ICC STEERING SWITCH

Refer to [EC-514, "Component Inspection"](#) .

OK or NG

OK >> GO TO 8.

NG >> Replace ICC steering switch.

8. CHECK INTERMITTENT INCIDENT

Refer to [EC-135, "TROUBLE DIAGNOSIS FOR INTERMITTENT INCIDENT"](#) .

>> **INSPECTION END**

Component Inspection ICC STEERING SWITCH

1. Disconnect combination switch (spiral cable).
2. Check continuity between combination switch (spiral cable) terminals 14 and 15 with pushing each switch.

Switch	Condition	Resistance [Ω]
ON/OFF(MAIN) switch	Pressed	Approx. 0
	Released	Approx. 5,500
COAST/SET switch	Pressed	Approx. 1,400
	Released	Approx. 5,500
ACCEL/ RESUME switch	Pressed	Approx. 2,600
	Released	Approx. 5,500
DISTANCE switch	Pressed	Approx. 740
	Released	Approx. 5,500
CANCEL switch	Pressed	Approx. 310
	Released	Approx. 5,500

If NG, replace ICC steering switch.

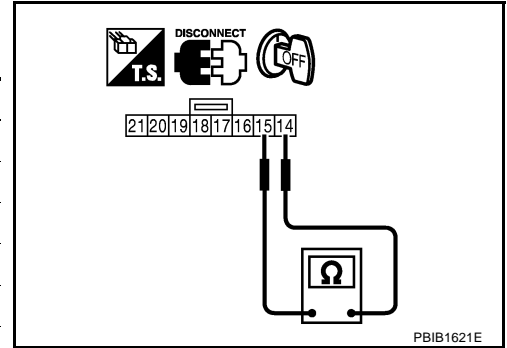

DTC P1564 ASCD STEERING SWITCH

PFP:25551

Component Description

ABS006W9

ASCD steering switch has variant values of electrical resistance for each button. ECM reads voltage variation of switch, and determines which button is operated.

Refer to [EC-657, "AUTOMATIC SPEED CONTROL DEVICE \(ASCD\)"](#) for the ASCD function.

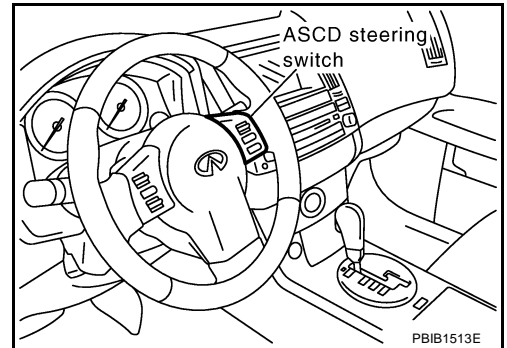

CONSULT-II Reference Value in Data Monitor Mode

ABS006WA

Specification data are reference values.

MONITOR ITEM	CONDITION		SPECIFICATION
MAIN SW	● Ignition switch: ON	ON/OFF(MAIN) switch: Pressed	ON
		ON/OFF(MAIN) switch: Released	OFF
CANCEL SW	● Ignition switch: ON	CANCEL switch: Pressed	ON
		CANCEL switch: Released	OFF
RESUME/ACC SW	● Ignition switch: ON	ACCEL/RESUME switch: Pressed	ON
		ACCEL/RESUME switch: Released	OFF
SET SW	● Ignition switch: ON	COAST/SET switch: Pressed	ON
		COAST/SET switch: Released	OFF

On Board Diagnosis Logic

ABS006WB

This self-diagnosis has the one trip detection logic.

The MIL will not light up for this diagnosis.

NOTE:

If DTC P1564 is displayed with DTC P0605, first perform the trouble diagnosis for DTC P0605. Refer to [EC-401](#).

DTC No.	Trouble Diagnosis Name	DTC Detecting Condition	Possible Cause
P1564 1564	ASCD steering switch	<ul style="list-style-type: none"> ● An excessively high voltage signal from the ASCD steering switch is sent to ECM. ● ECM detects that input signal from the ASCD steering switch is out of the specified range. ● ECM detects that the ASCD steering switch is stuck ON. 	<ul style="list-style-type: none"> ● Harness or connectors (The switch circuit is open or shorted.) ● ASCD steering switch ● ECM

DTC Confirmation Procedure

NOTE:

If DTC Confirmation Procedure has been previously conducted, always turn ignition switch OFF and wait at least 10 seconds before conducting the next test.

⑧ WITH CONSULT-II

1. Turn ignition switch ON.
2. Select "DATA MONITOR" mode with CONSULT-II.
3. Wait at least 10 seconds.
4. Press ON/OFF(MAIN) switch for at least 10 seconds, then release it and wait at least 10 seconds.
5. Press ACCEL/RESUME switch for at least 10 seconds, then release it and wait at least 10 seconds.
6. Press COAST/SET switch for at least 10 seconds, then release it and wait at least 10 seconds.
7. Press CANCEL switch for at least 10 seconds, then release it and wait at least 10 seconds.
8. If DTC is detected, go to [EC-518, "Diagnostic Procedure"](#).

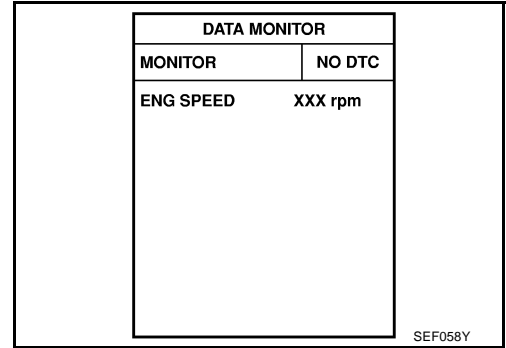

⑧ WITH GST

Follow the procedure "WITH CONSULT-II" above.

DTC P1564 ASCD STEERING SWITCH

[VQ35DE]

Wiring Diagram

ABS006WD

EC-ASC/SW-01

— : DETECTABLE LINE FOR DTC
— : NON-DETECTABLE LINE FOR DTC

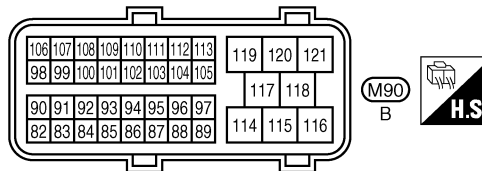
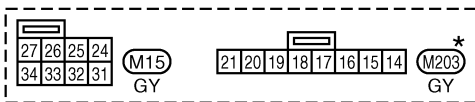
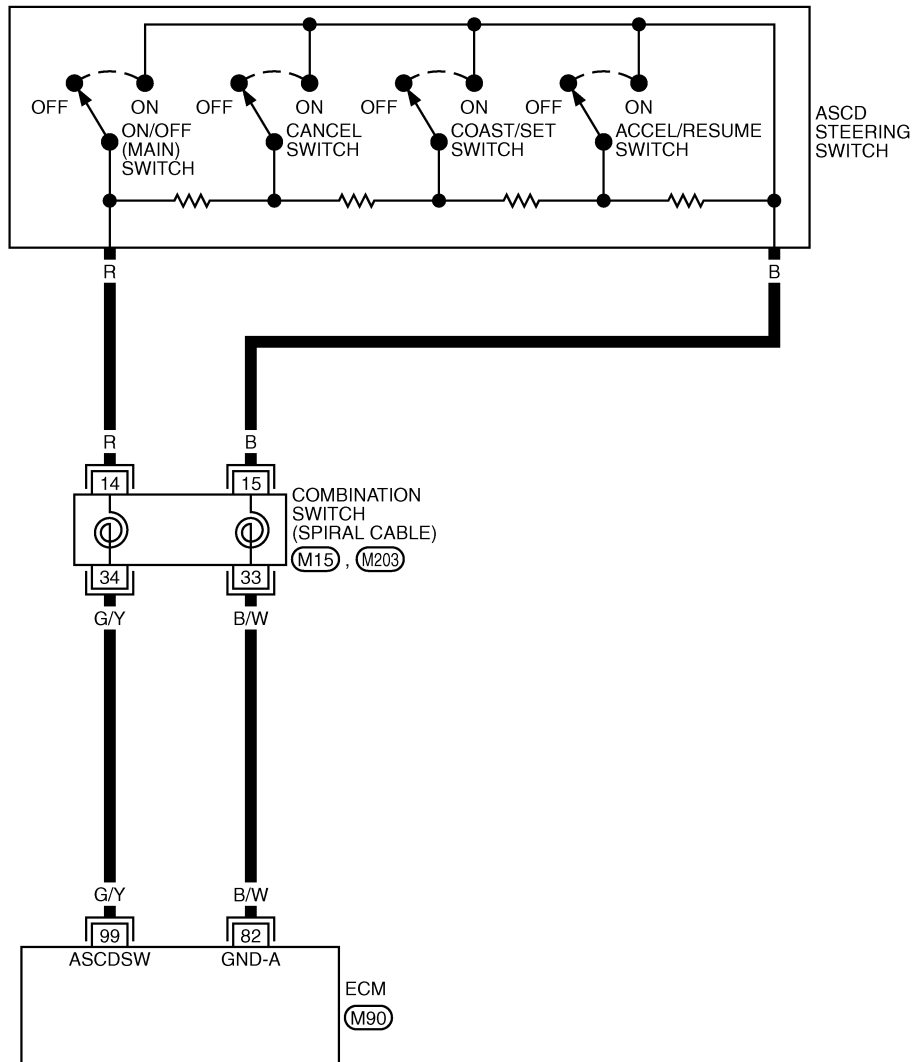

*: THIS CONNECTOR IS NOT SHOWN IN "HARNESS LAYOUT", PG SECTION.

TBWM0257E

DTC P1564 ASCD STEERING SWITCH

[VQ35DE]

Specification data are reference values and are measured between each terminal and ground.

CAUTION:

Do not use ECM ground terminals when measuring input/output voltage. Doing so may result in damage to the ECM's transistor. Use a ground other than ECM terminals, such as the ground.

TER-MINAL NO.	WIRE COLOR	ITEM	CONDITION	DATA (DC Voltage)
82	B/W	Sensor ground (ASCD steering switch)	[Engine is running] <ul style="list-style-type: none"> ● Warm-up condition ● Idle speed 	Approximately 0V
99	G/Y	ASCD steering switch	[Ignition switch: ON] <ul style="list-style-type: none"> ● ASCD steering switch: OFF 	Approximately 4V
			[Ignition switch: ON] <ul style="list-style-type: none"> ● ON/OFF(MAIN) switch: Pressed 	Approximately 0V
			[Ignition switch: ON] <ul style="list-style-type: none"> ● CANCEL switch: Pressed 	Approximately 1V
			[Ignition switch: ON] <ul style="list-style-type: none"> ● COAST/SET switch: Pressed 	Approximately 2V
			[Ignition switch: ON] <ul style="list-style-type: none"> ● ACCEL/RESUME switch: Pressed 	Approximately 3V

Diagnostic Procedure

ABS00CHT

1. CHECK GROUND CONNECTIONS

1. Turn ignition switch OFF.
2. Loosen and retighten ground three screws on the body. Refer to [EC-141, "Ground Inspection"](#).

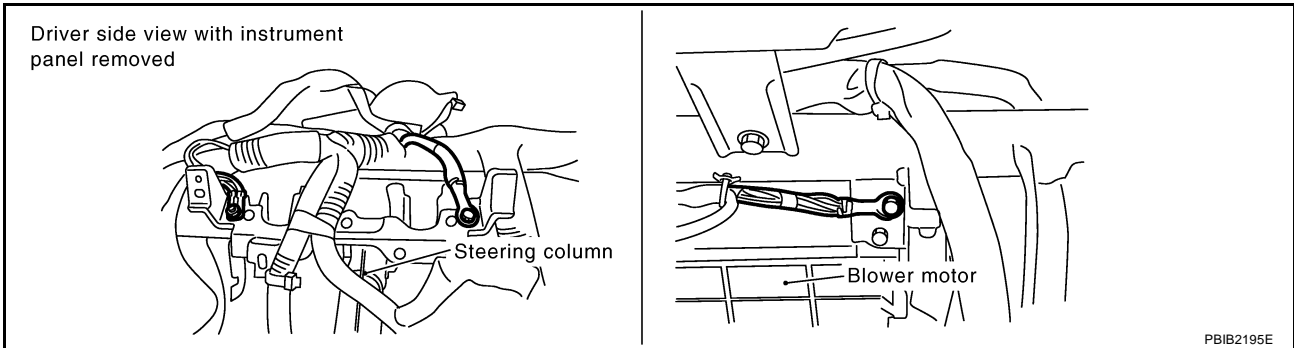

OK or NG

- OK >> GO TO 2.
- NG >> Repair or replace ground connections.

2. CHECK ASCD STEERING SWITCH CIRCUIT

☑ With CONSULT-II

1. Turn ignition switch ON.
2. Select "MAIN SW", "RESUME/ACC SW", "SET SW" and "CANCEL SW" in "DATA MONITOR" mode with CONSULT-II.
3. Check each item indication under the following conditions.

Switch	Monitor item	Condition	Indication
ON/OFF(MAIN) switch	MAIN SW	Pressed	ON
		Released	OFF
COAST/SET switch	SET SW	Pressed	ON
		Released	OFF
ACCEL/RESUME switch	RESUME/ACC SW	Pressed	ON
		Released	OFF
CANCEL switch	CANCEL SW	Pressed	ON
		Released	OFF

DATA MONITOR	
MONITOR	NO DTC
MAIN SW	OFF
CANCEL SW	OFF
RESUME/ACC SW	OFF
SET SW	OFF

SEC006D

☒ Without CONSULT-II

1. Turn ignition switch ON.
2. Check voltage between ECM terminal 99 and ground with pressing each button.

Switch	Condition	Voltage [V]
ON/OFF(MAIN) switch	Pressed	Approx. 0
	Released	Approx. 4
COAST/SET switch	Pressed	Approx. 2
	Released	Approx. 4
ACCEL/RESUME switch	Pressed	Approx. 3
	Released	Approx. 4
CANCEL switch	Pressed	Approx. 1
	Released	Approx. 4

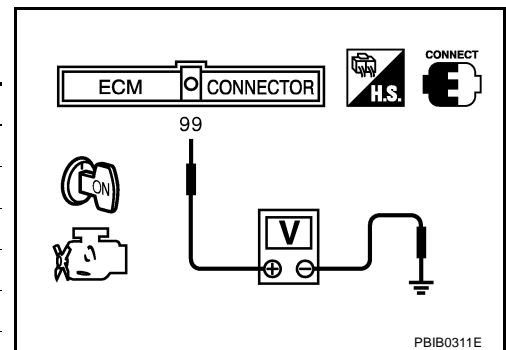

OK or NG

- OK >> GO TO 8.
 NG >> GO TO 3.

3. CHECK ASCD STEERING SWITCH GROUND CIRCUIT FOR OPEN AND SHORT

1. Turn ignition switch OFF.
2. Disconnect combination switch harness connector.
3. Disconnect ECM harness connector.
4. Check harness continuity between combination switch terminal 15 and ECM terminal 82. Refer to Wiring Diagram.

Continuity should exist.

5. Also check harness for short to ground and short to power.

OK or NG

- OK >> GO TO 5.
 NG >> GO TO 4.

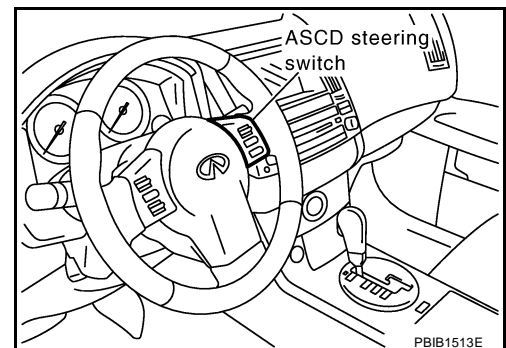

4. DETECT MALFUNCTIONING PART

Check the following.

- Combination switch (spiral cable)
- Harness for open and short between ECM and combination switch

>> Repair open circuit or short to power in harness or connectors.

5. CHECK ASCD STEERING SWITCH INPUT SIGNAL CIRCUIT FOR OPEN AND SHORT

1. Check harness continuity between ECM terminal 99 and combination switch terminal 14. Refer to Wiring Diagram.

Continuity should exist.

2. Also check harness for short to ground and short to power.

OK or NG

- OK >> GO TO 7.
- NG >> GO TO 6.

6. DETECT MALFUNCTIONING PART

Check the following.

- Combination switch (spiral cable)
- Harness for open and short between ECM and combination switch

>> Repair open circuit or short to ground or short to power in harness or connectors.

7. CHECK ASCD STEERING SWITCH

Refer to [EC-520, "Component Inspection"](#) .

OK or NG

- OK >> GO TO 8.
- NG >> Replace steering wheel.

8. CHECK INTERMITTENT INCIDENT

Refer to [EC-135, "TROUBLE DIAGNOSIS FOR INTERMITTENT INCIDENT"](#) .

>> INSPECTION END

**Component Inspection
ASC D STEERING SWITCH**

ABS006WF

1. Disconnect combination switch (spiral cable).
2. Check continuity between combination switch (spiral cable) terminals 14 and 15 with pushing each switch.

Switch	Condition	Resistance [Ω]
ON/OFF(MAIN) switch	Pressed	Approx. 0
	Released	Approx. 4,000
COAST/SET switch	Pressed	Approx. 660
	Released	Approx. 4,000
ACCEL/RESUME switch	Pressed	Approx. 1,480
	Released	Approx. 4,000
CANCEL switch	Pressed	Approx. 250
	Released	Approx. 4,000

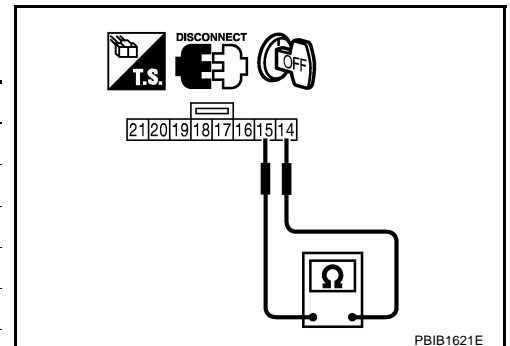

PBIB1621E

DTC P1568 ICC FUNCTION

PFP:18995

On Board Diagnosis Logic

ABS006WG

NOTE:

- If DTC P1568 is displayed with DTC U1000, U1001, first perform the trouble diagnosis for DTC U1000, U1001. Refer to [EC-142](#) .
- If DTC P1568 is displayed with DTC P0605, first perform the trouble diagnosis for DTC P0605. Refer to [EC-401](#)
- This self-diagnosis has the one trip detection logic.
- The MIL will not light up for this self-diagnosis.

DTC No.	Trouble Diagnosis Name	DTC Detecting Condition	Possible Cause
P1568 1568	ICC function	ECM detects a difference between signals from ICC unit is out of specified range.	<ul style="list-style-type: none"> ● Harness or connectors (The CAN communication line is open or shorted.) ● ICC unit ● ECM

DTC Confirmation Procedure

ABS006WH

CAUTION:

Always drive vehicle at a safe speed.

NOTE:

- If DTC Confirmation Procedure has been previously conducted, always turn ignition switch OFF and wait at least 10 seconds before conducting the next test.
- **Step 4 may be conducted with the drive wheels lifted in the shop or by driving the vehicle. If a road test is expected to be easier, it is unnecessary to lift the vehicle.**

ⓑ WITH CONSULT-II

1. Turn ignition switch ON.
2. Select "DATA MONITOR" mode with CONSULT-II.
3. Press ON/OFF(MAIN) switch on ICC steering switch.
4. Drive the vehicle at more than 40 km/h (25 MPH).
5. Press COAST/SET switch.
6. If DTC is detected, go to [EC-521, "Diagnostic Procedure"](#) .

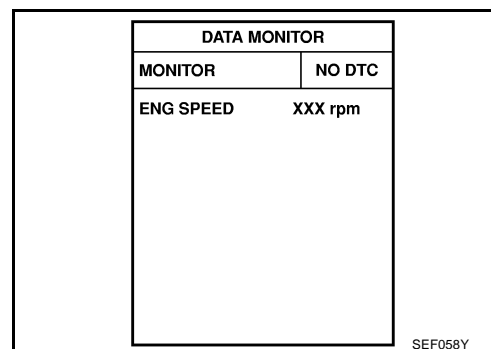

Ⓒ WITH GST

Follow the procedure "WITH CONSULT-II" above.

Diagnostic Procedure

ABS006WI

1. REPLACE ICC UNIT

1. Replace ICC unit.
2. Perform [ACS-9, "ACTION TEST"](#) .
3. Check DTC of ICC unit. Refer to [ACS-40, "TROUBLE DIAGNOSIS FOR SELF-DIAGNOSTIC ITEMS"](#) .

>> INSPECTION END

DTC P1572 ICC BRAKE SWITCH

PFP:25320

Component Description

ABS007Z6

When the brake pedal is depressed, ICC brake switch is turned OFF and stop lamp switch is turned ON. ECM detects the state of the brake pedal by this input of two kinds (ON/OFF signal). Refer to [ACS-6, "DESCRIPTION"](#) for the ICC function.

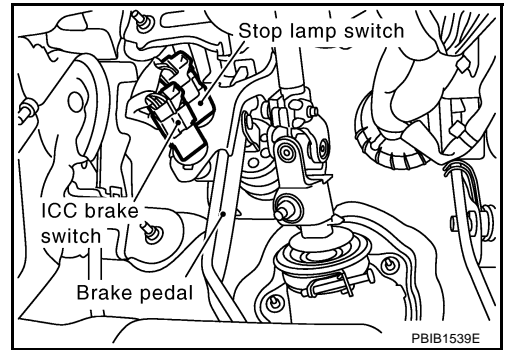

CONSULT-II Reference Value in Data Monitor Mode

ABS007Z7

Specification data are reference values.

MONITOR ITEM	CONDITION		SPECIFICATION
BRAKE SW1 (ICC brake switch)	● Ignition switch: ON	● Brake pedal: Fully released	ON
		● Brake pedal: Slightly depressed	OFF
BRAKE SW2 (Stop lamp switch)	● Ignition switch: ON	● Brake pedal: Fully released	OFF
		● Brake pedal: Slightly depressed	ON

On Board Diagnosis Logic

ABS007Z8

NOTE:

This diagnosis has the one trip detection logic.
The MIL will not light up for this self-diagnosis.

- If DTC P1572 is displayed with DTC P0605, first perform the trouble diagnosis for DTC P0605. Refer to [EC-401](#).
- This self-diagnosis has the one trip detection logic. When malfunction A is detected, DTC is not stored in ECM memory. And in that case, 1st trip DTC and 1st trip freeze frame data are displayed. 1st trip DTC is erased when ignition switch OFF. And even when malfunction A is detected in two consecutive trips, DTC is not stored in ECM memory.

DTC No.	Trouble diagnosis name	DTC detecting condition		Possible cause
P1572 1572	ICC brake switch	A)	● ON signals from the stop lamp switch and the ICC brake switch are sent to ECM at the same time.	<ul style="list-style-type: none"> ● Harness or connectors (The stop lamp switch circuit is open or shorted.) ● Harness or connectors (The ICC brake switch circuit is open or shorted.) ● Stop lamp switch ● ICC brake switch ● ICC brake hold relay ● Incorrect stop lamp switch installation ● Incorrect ICC brake switch installation ● ECM
		B)	● ICC brake switch signal is not sent to ECM for extremely long time while the vehicle is driving.	

DTC Confirmation Procedure

CAUTION:

Always drive vehicle at a safe speed.

NOTE:

- If DTC Confirmation Procedure has been previously conducted, always turn ignition switch OFF and wait at least 10 seconds before conducting the next test.
- Procedure for malfunction B is not described here. It takes extremely long time to complete procedure for malfunction B. By performing procedure for malfunction A, the incident that causes malfunction B can be detected.

TESTING CONDITION:

Steps 3 and 4 may be conducted with the drive wheels lifted in the shop or by driving the vehicle. If a road test is expected to be easier, it is unnecessary to lift the vehicle.

WITH CONSULT-II

1. Start engine.
2. Select "DATA MONITOR" mode with CONSULT-II.
3. Press MAIN switch and make sure that CRUISE indicator lights up.
4. Drive the vehicle for at least 5 consecutive seconds under the following condition.

VHCL SPEED SE	More than 30 km/h (19 MPH)
Selector lever	Suitable position

If 1st trip DTC is detected, go to [EC-525, "Diagnostic Procedure"](#)

If 1st trip DTC is not detected, go to the following step.

5. Drive the vehicle for at least 5 consecutive seconds under the following condition.

VHCL SPEED SE	More than 30 km/h (19 MPH)
Selector lever	Suitable position
Driving location	Depress the brake pedal for more than five seconds so as not to come off from the above-mentioned vehicle speed.

6. If 1st trip DTC is detected, go to [EC-525, "Diagnostic Procedure"](#) .

WITH GST

Follow the procedure "WITH CONSULT-II" above.

DATA MONITOR	
MONITOR	NO DTC
ENG SPEED	XXX rpm
VHCL SPEED SE	XXX km/h
CRUISE LAMP	ON
BRAKE SW 1	ON
BRAKE SW 2	OFF

PBIB2386E

DTC P1572 ICC BRAKE SWITCH

[VQ35DE]

ABS007ZA

Wiring Diagram

EC-ICC/BS-01

— : DETECTABLE LINE FOR DTC
 - - - : NON-DETECTABLE LINE FOR DTC

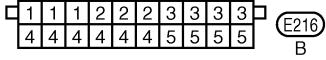
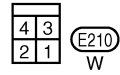
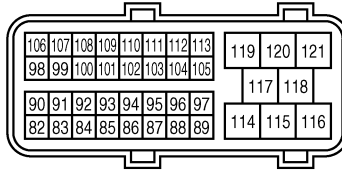
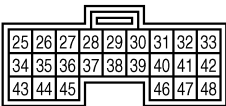
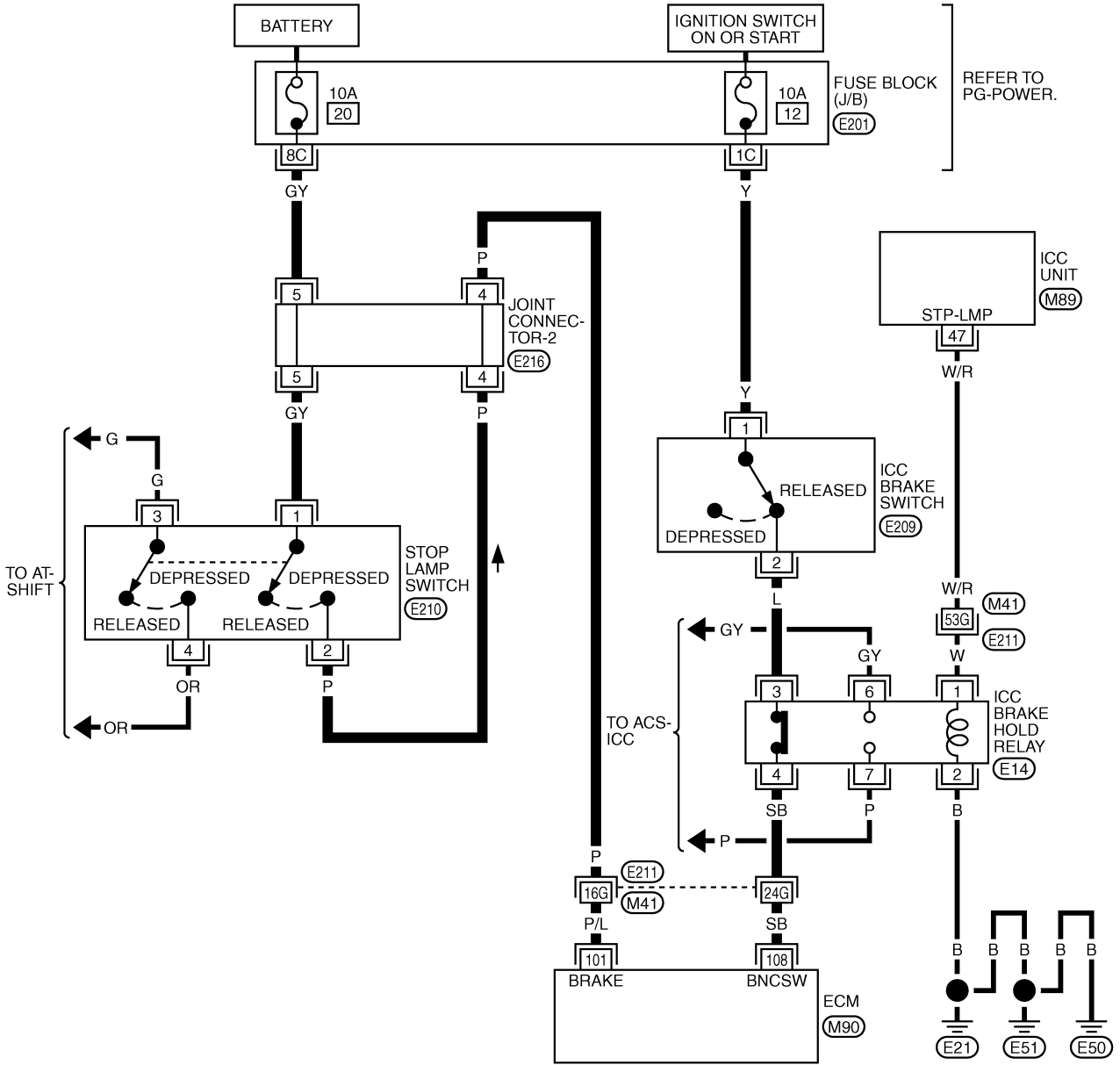

REFER TO THE FOLLOWING.
 (E21) -SUPER MULTIPLE JUNCTION (SMJ)
 (E201) -FUSE BLOCK-JUNCTION BOX (J/B)

TBWM0274E

DTC P1572 ICC BRAKE SWITCH

[VQ35DE]

Specification data are reference values and are measured between each terminal and ground.

CAUTION:

Do not use ECM ground terminals when measuring input/output voltage. Doing so may result in damage to the ECM's transistor. Use a ground other than ECM terminals, such as the ground.

TERMI- NAL NO.	WIRE COLOR	ITEM	CONDITION	DATA (DC Voltage)
101	P/L	Stop lamp switch	[Ignition switch: OFF] ● Brake pedal: Fully released	Approximately 0V
			[Ignition switch: OFF] ● Brake pedal: Slightly depressed	BATTERY VOLTAGE (11 - 14V)
108	SB	ICC brake switch	[Ignition switch: ON] ● Brake pedal: Slightly depressed	Approximately 0V
			[Ignition switch: ON] ● Brake pedal: Fully released	BATTERY VOLTAGE (11 - 14V)

Diagnostic Procedure

ABS00DAI

1. CHECK OVERALL FUNCTION-I

 **With CONSULT-II**

- Turn ignition switch "ON".
- Select "BRAKE SW1" in "DATA MONITOR" mode with CONSULT-II.
- Check "BRAKE SW1" indication under the following conditions.

CONDITION	INDICATION
When brake pedal is depressed	OFF
When brake pedal is fully released	ON

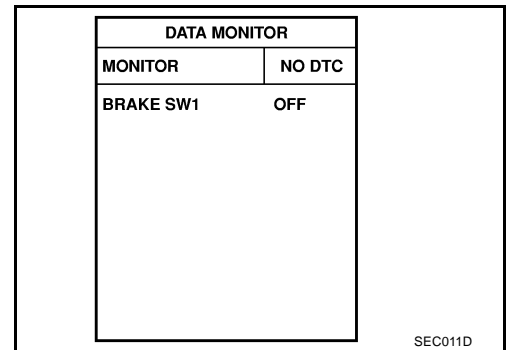

 **Without CONSULT-II**

- Turn ignition switch "ON".
- Check voltage between ECM terminal 108 and ground under the following conditions.

CONDITION	VOLTAGE
When brake pedal is depressed	Approximately 0V
When brake pedal is fully released	Battery voltage

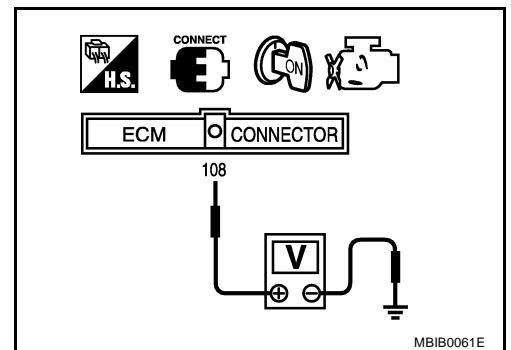

OK or NG

- OK >> GO TO 2.
- NG >> GO TO 3.

2. CHECK OVERALL FUNCTION-II

With CONSULT-II

Check "BRAKE SW2" indication in "DATA MONITOR" mode.

CONDITION	INDICATION
When brake pedal is released	OFF
When brake pedal is depressed	ON

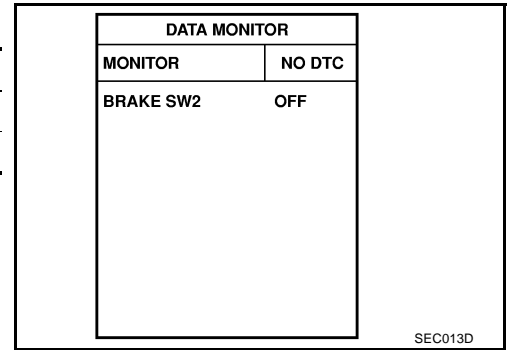

Without CONSULT-II

Check voltage between ECM terminal 101 and ground under the following conditions.

CONDITION	VOLTAGE
When brake pedal is released	Approximately 0V
When brake pedal is depressed	Battery voltage

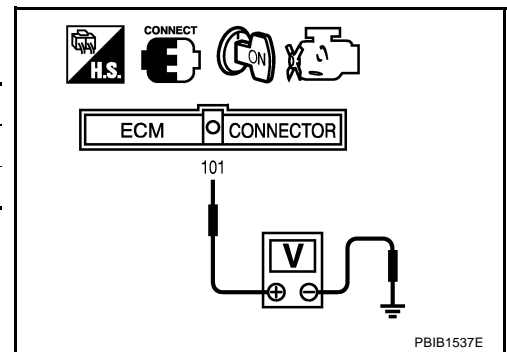

OK or NG

- OK >> GO TO 17.
- NG >> GO TO 12.

3. CHECK DTC WITH ICC UNIT

Refer to [ACS-40, "TROUBLE DIAGNOSIS FOR SELF-DIAGNOSTIC ITEMS"](#) .

OK or NG

- OK >> GO TO 4.
- NG >> Repair or replace.

4. CHECK ICC BRAKE SWITCH CIRCUIT

1. Turn ignition switch "OFF".
2. Disconnect ICC brake hold relay.
3. Turn ignition switch "ON".

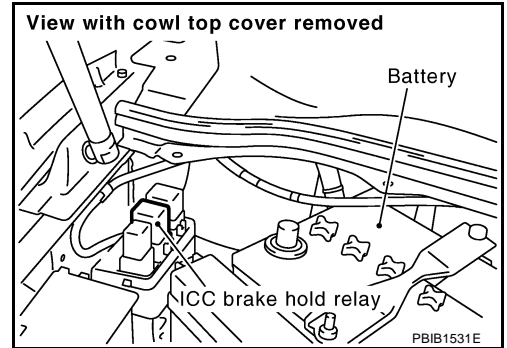

4. Check voltage between ICC brake hold relay terminal 3 and ground with CONSULT-II or tester.

Voltage: Battery voltage

OK or NG

- OK >> GO TO 9.
- NG >> GO TO 5.

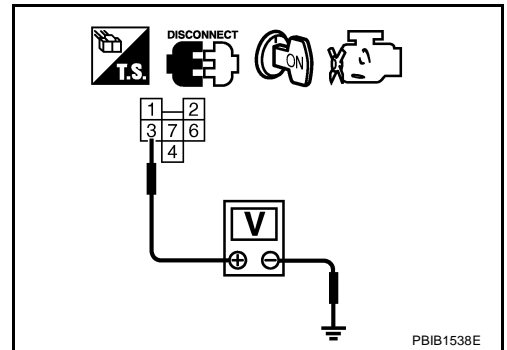

5. CHECK ICC BRAKE SWITCH POWER SUPPLY CIRCUIT

1. Turn ignition switch "OFF".
2. Disconnect ICC brake switch harness connector.
3. Turn ignition switch "ON".

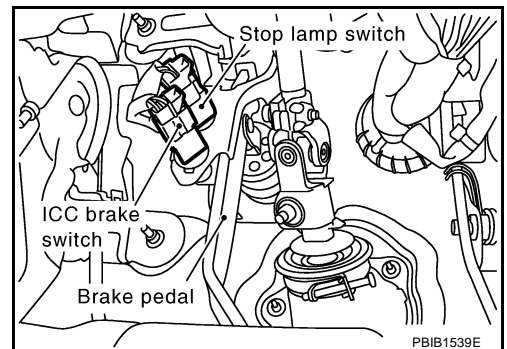

4. Check voltage between ICC brake switch terminal 1 and ground with CONSULT-II or tester.

Voltage: Battery voltage

OK or NG

- OK >> GO TO 7.
- NG >> GO TO 6.

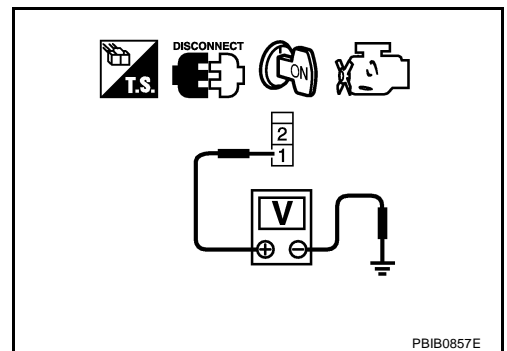

6. DETECT MALFUNCTIONING PART

Check the following.

- Fuse block (J/B) connector E201
- 10A fuse
- Harness for open or short between ICC brake switch and fuse

>> Repair open circuit or short to ground or short to power in harness or connectors.

7. CHECK ICC BRAKE SWITCH INPUT SIGNAL CIRCUIT FOR OPEN AND SHORT-I

1. Turn ignition switch "OFF".
2. Check harness continuity between ICC brake hold relay terminal 3 and ICC brake switch terminal 2. Refer to Wiring Diagram.

Continuity should exist.

3. Also check harness for short to ground and short to power.

OK or NG

OK >> GO TO 8.

NG >> Repair open circuit or short to ground or short to power in harness or connectors.

8. CHECK ICC BRAKE SWITCH

Refer to [EC-1197, "Component Inspection"](#) .

OK or NG

OK >> GO TO 17.

NG >> Replace ICC brake switch.

9. CHECK ICC BRAKE SWITCH INPUT SIGNAL CIRCUIT FOR OPEN AND SHORT-II

1. Turn ignition switch "OFF".
2. Disconnect ECM harness connector.
3. Check harness continuity between ICC brake hold relay terminal 4 and ECM terminal 108. Refer Wiring Diagram.

Continuity should exist.

4. Also check harness for short to ground and short to power.

OK or NG

OK >> GO TO 11.

NG >> GO TO 10.

10. DETECT MALFUNCTIONING PART

Check the following.

- Harness connectors E211, M41
- Harness for open or short between ICC brake hold relay and ECM

>> Repair open circuit or short to ground or short to power in harness or connectors.

11. CHECK ICC BRAKE HOLD RELAY

Refer to [EC-1197, "Component Inspection"](#) .

OK >> GO TO 17.

NG >> Replace ICC brake hold relay.

12. CHECK STOP LAMP SWITCH POWER SUPPLY CIRCUIT

1. Turn ignition switch "OFF".
2. Disconnect stop lamp switch harness connector.

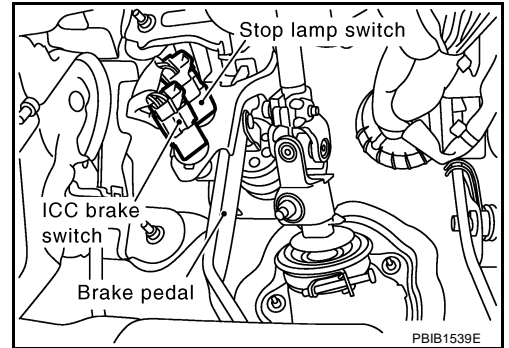

3. Check voltage between stop lamp switch terminal 1 and ground with CONSULT -II or tester.

Voltage: Battery voltage

OK or NG

- OK >> GO TO 14.
- NG >> GO TO 13.

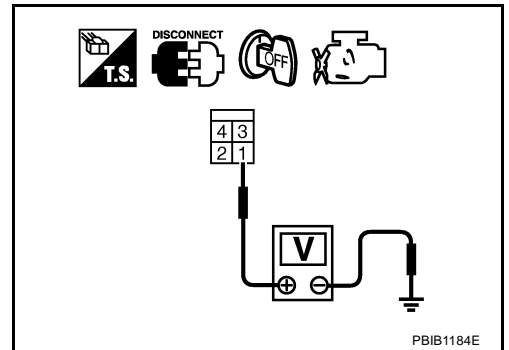

13. DETECT MALFUNCTIONING PART

Check the following.

- Joint connector-2
- Fuse block (J/B) connector E201
- 10A fuse
- Harness for open or short between stop lamp switch and fuse

>> Repair open circuit or short to ground or short to power in harness or connectors.

14. CHECK STOP LAMP SWITCH INPUT SIGNAL CIRCUIT FOR OPEN AND SHORT

1. Disconnect ECM harness connector.
2. Check harness continuity between ECM terminal 101 and stop lamp switch terminal 2. Refer to Wiring Diagram.

Continuity should exist.

3. Also check harness for short to ground and short to power.

OK or NG

- OK >> GO TO 16.
- NG >> GO TO 15.

15. DETECT MALFUNCTIONING PART

Check the following.

- Harness connectors E211, M41
- Joint connector-2
- Harness for open or short between ECM and stop lamp switch

>> Repair open circuit or short to ground or short to power in harness or connectors.

16. CHECK STOP LAMP SWITCH

Refer to [EC-1197, "Component Inspection"](#)

OK or NG

OK >> GO TO 17.

NG >> Replace stop lamp switch.

17. CHECK INTERMITTENT INCIDENT

Refer to [EC-784, "TROUBLE DIAGNOSIS FOR INTERMITTENT INCIDENT"](#) .

>> INSPECTION END

Component Inspection ICC BRAKE SWITCH

ABS007ZC

1. Turn ignition switch OFF.
2. Disconnect ICC brake switch harness connector.
3. Check continuity between ICC brake switch terminals 1 and 2 under the following conditions.

Condition	Continuity
When brake pedal is fully released.	Should exist.
When brake pedal is slightly depressed.	Should not exist.

If NG, adjust ICC brake switch installation, refer to [BR-6, "BRAKE PEDAL"](#) , and perform step 3 again.

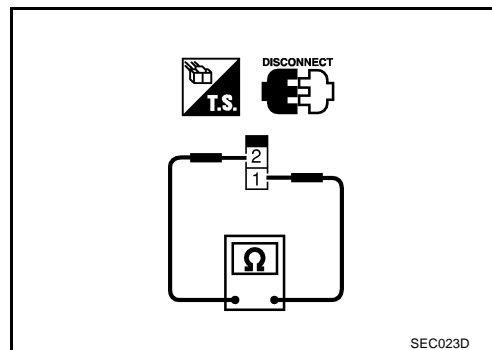

STOP LAMP SWITCH

1. Turn ignition switch OFF.
2. Disconnect stop lamp switch harness connector.
3. Check continuity between stop lamp switch terminals 1 and 2 under the following conditions.

Condition	Continuity
When brake pedal is fully released.	Should not exist.
When brake pedal is slightly depressed.	Should exist.

If NG, adjust stop lamp switch installation, refer to [BR-6, "BRAKE PEDAL"](#) , and perform step 3 again.

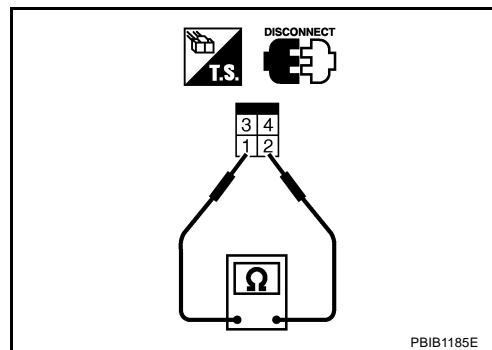

ICC BRAKE HOLD RELAY

1. Apply 12V direct current between ICC brake hold relay terminals 1 and 2.

DTC P1572 ICC BRAKE SWITCH

[VQ35DE]

2. Check continuity between relay terminals 3 and 4, 6 and 7 under the following conditions.

Condition	Between terminals	Continuity
12V direct current supply between terminals 1 and 2	3 and 4	Should not exist
	6 and 7	Should exist
No current supply	3 and 4	Should exist
	6 and 7	Should not exist

3. If NG, replace ICC brake hold relay.

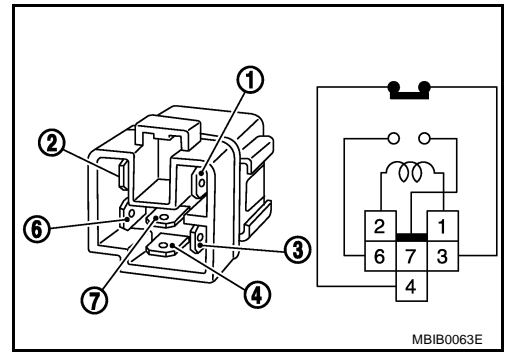

A
EC
C
D
E
F
G
H
I
J
K
L
M

DTC P1572 ASCD BRAKE SWITCH

PFP:25320

Component Description

ABS006WJ

When the brake pedal is depressed, ASCD brake switch is turned OFF and stop lamp switch is turned ON. ECM detects the state of the brake pedal by this input of two kinds (ON/OFF signal).

Refer to [EC-657, "AUTOMATIC SPEED CONTROL DEVICE \(ASCD\)"](#) for the ASCD function.

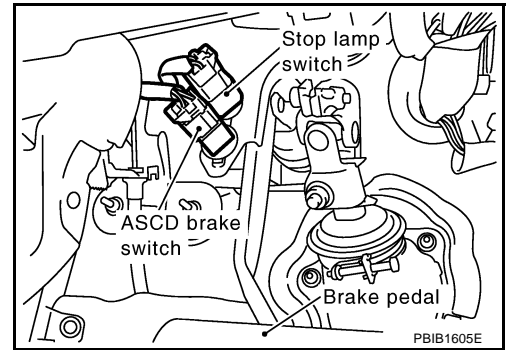

CONSULT-II Reference Value in Data Monitor Mode

ABS006WK

Specification data are reference values.

MONITOR ITEM	CONDITION		SPECIFICATION
BRAKE SW1 (ASCD brake switch)	● Ignition switch: ON	● Brake pedal: Fully released	ON
		● Brake pedal: Slightly depressed	OFF
BRAKE SW2 (Stop lamp switch)	● Ignition switch: ON	● Brake pedal: Fully released	OFF
		● Brake pedal: Slightly depressed	ON

On Board Diagnosis Logic

ABS006WL

This self-diagnosis has the one trip detection logic.

The MIL will not light up for this diagnosis.

NOTE:

- If DTC P 1572 is displayed with DTC P0605, first perform the trouble diagnosis for DTC P0605. Refer to [EC-401](#).
- This self-diagnosis has the one trip detection logic. When malfunction A is detected, DTC is not stored in ECM memory. And in that case, 1st trip DTC and 1st trip freeze frame data are displayed. 1st trip DTC is erased when ignition switch OFF. And even when malfunction A is detected in two consecutive trips, DTC is not stored in ECM memory.

DTC No.	Trouble diagnosis name	DTC detecting condition		Possible cause
P1572 1572	ASCD brake switch	A)	<ul style="list-style-type: none"> ● When the vehicle speed is above 30 km/h (19 MPH), ON signals from the stop lamp switch and the ASCD brake switch are sent to the ECM at the same time. 	<ul style="list-style-type: none"> ● Harness or connectors (The stop lamp switch circuit is open or shorted.) ● Harness or connectors (The ASCD brake switch circuit is open or shorted.) ● Stop lamp switch ● ASCD brake switch ● Incorrect stop lamp switch installation ● Incorrect ASCD brake switch installation ● ECM
		B)	<ul style="list-style-type: none"> ● ASCD brake switch signal is not sent to ECM for extremely long time while the vehicle is driving. 	

DTC Confirmation Procedure

CAUTION:

Always drive vehicle at a safe speed.

NOTE:

- If DTC Confirmation Procedure has been previously conducted, always turn ignition switch OFF and wait at least 10 seconds before conducting the next test.
- Procedure for malfunction B is not described here. It takes extremely long time to complete procedure for malfunction B. By performing procedure for malfunction A, the incident that causes malfunction B can be detected.

TESTING CONDITION:

Steps 3 and 4 may be conducted with the drive wheels lifted in the shop or by driving the vehicle. If a road test is expected to be easier, it is unnecessary to lift the vehicle.

WITH CONSULT-II

1. Start engine (TCS switch or VDC switch OFF).
2. Select "DATA MONITOR" mode with CONSULT-II.
3. Press MAIN switch and make sure that CRUISE indicator lights up.
4. Drive the vehicle for at least 5 consecutive seconds under the following conditions.

VHCL SPEED SE	More than 30 km/h (19 MPH)
Selector lever	Suitable position

If 1st trip DTC is detected, go to [EC-535, "Diagnostic Procedure"](#)

If 1st trip DTC is not detected, go to the following step.

5. Drive the vehicle for at least 5 consecutive seconds under the following conditions.

VHCL SPEED SE	More than 30 km/h (19 MPH)
Selector lever	Suitable position
Driving location	Depress the brake pedal for more than five seconds so as not to come off from the above-mentioned vehicle speed.

6. If 1st trip DTC is detected, go to [EC-535, "Diagnostic Procedure"](#) .

WITH GST

Follow the procedure "WITH CONSULT-II" above.

DATA MONITOR	
MONITOR	NO DTC
ENG SPEED	XXX rpm
VHCL SPEED SE	XXX km/h
CRUISE LAMP	ON
BRAKE SW 1	ON
BRAKE SW 2	OFF

PBIB2386E

DTC P1572 ASCD BRAKE SWITCH

[VQ35DE]

ABS006WN

Wiring Diagram

EC-ASC/BS-01

: DETECTABLE LINE FOR DTC
 : NON-DETECTABLE LINE FOR DTC

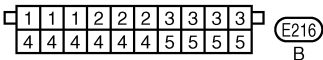
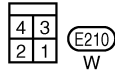
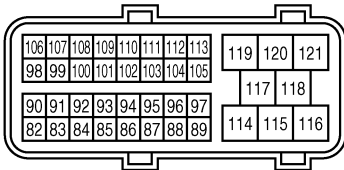
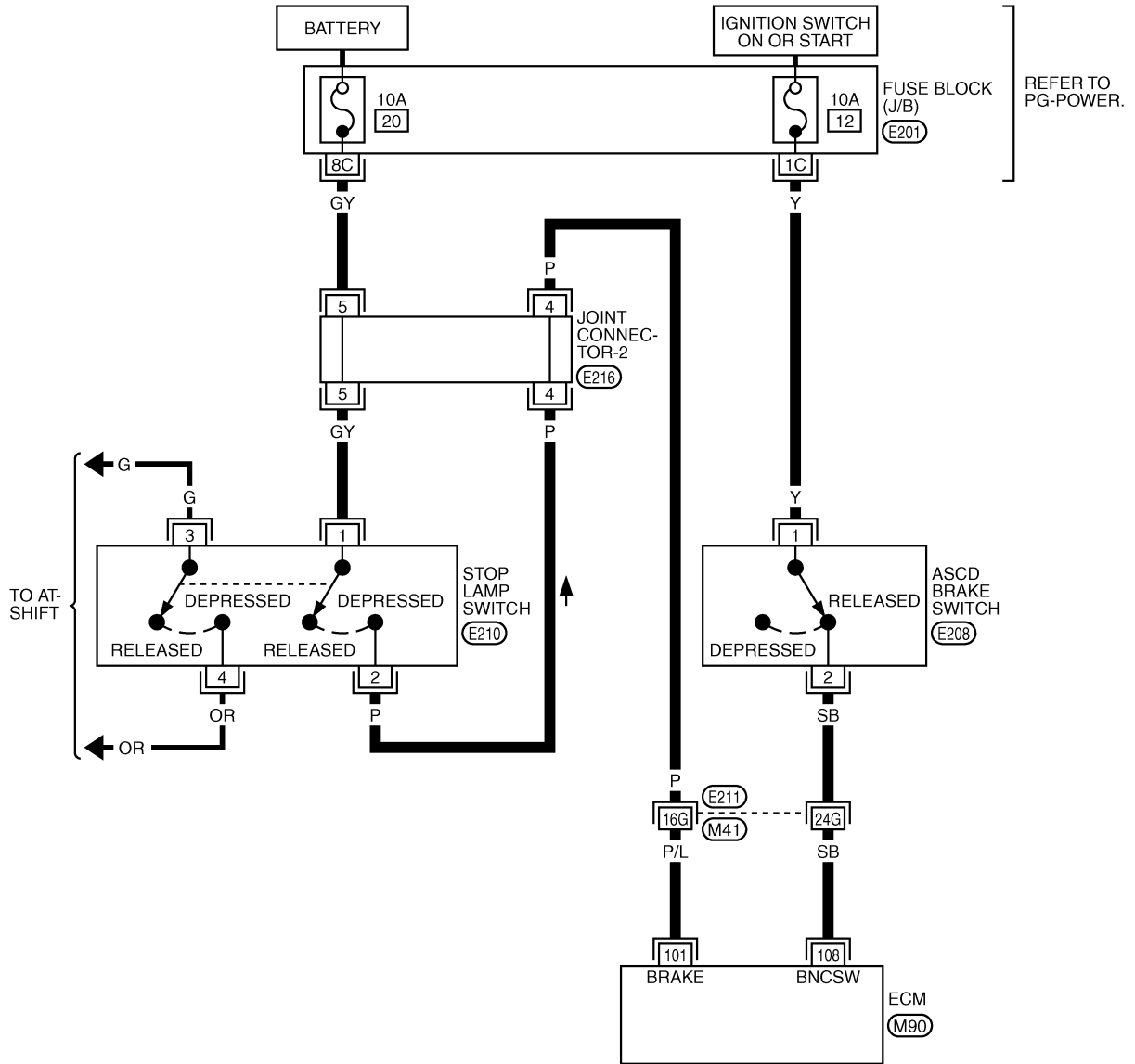

REFER TO THE FOLLOWING.

(E211) -SUPER MULTIPLE JUNCTION (SMJ)

(E201) -FUSE BLOCK-JUNCTION BOX (J/B)

TBWM0258E

DTC P1572 ASCD BRAKE SWITCH

[VQ35DE]

Specification data are reference values and are measured between each terminal and ground.

CAUTION:

Do not use ECM ground terminals when measuring input/output voltage. Doing so may result in damage to the ECM's transistor. Use a ground other than ECM terminals, such as the ground.

TER-MINAL NO.	WIRE COLOR	ITEM	CONDITION	DATA (DC Voltage)
101	P/L	Stop lamp switch	[Ignition switch: OFF] ● Brake pedal: Fully released	Approximately 0V
			[Ignition switch: OFF] ● Brake pedal: Slightly depressed	BATTERY VOLTAGE (11 - 14V)
108	SB	ASCD brake switch	[Ignition switch: ON] ● Brake pedal: Slightly depressed	Approximately 0V
			[Ignition switch: ON] ● Brake pedal: Fully released	BATTERY VOLTAGE (11 - 14V)

Diagnostic Procedure

ABS006WO

1. CHECK OVERALL FUNCTION-I

With CONSULT-II

- Turn ignition switch ON.
- Select "BRAKE SW1" in "DATA MONITOR" mode with CONSULT-II.
- Check "BRAKE SW1" indication under the following conditions.

CONDITION	INDICATION
When brake pedal is slightly depressed	OFF
When brake pedal is fully released	ON

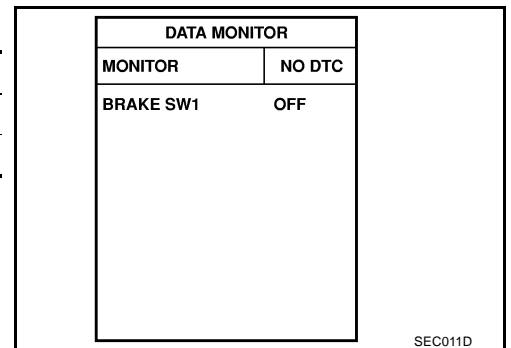

Without CONSULT-II

- Turn ignition switch ON.
- Check voltage between ECM terminal 108 and ground under the following conditions.

CONDITION	VOLTAGE
When brake pedal is slightly depressed	Approximately 0V
When brake pedal is fully released	Battery voltage

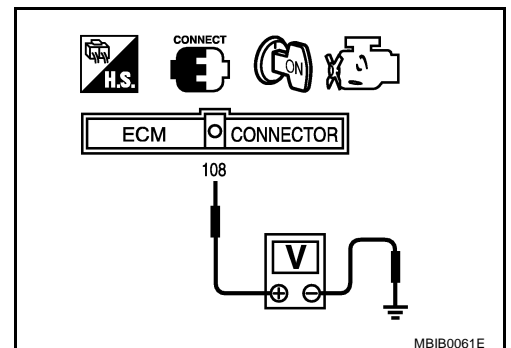

OK or NG

- OK >> GO TO 2.
- NG >> GO TO 3.

DTC P1572 ASCD BRAKE SWITCH

[VQ35DE]

2. CHECK OVERALL FUNCTION-II

With CONSULT-II

Check "BRAKE SW2" indication in "DATA MONITOR" mode.

CONDITION	INDICATION
When brake pedal is fully released	OFF
When brake pedal is slightly depressed	ON

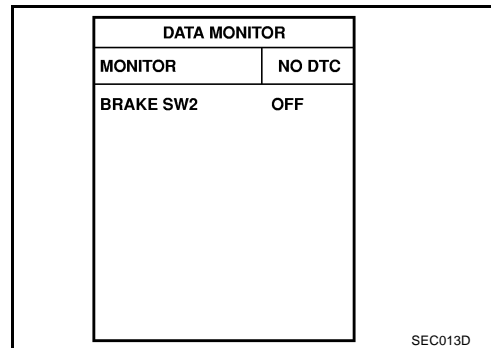

Without CONSULT-II

Check voltage between ECM terminal 101 and ground under the following conditions.

CONDITION	VOLTAGE
When brake pedal is fully released	Approximately 0V
When brake pedal is slightly depressed	Battery voltage

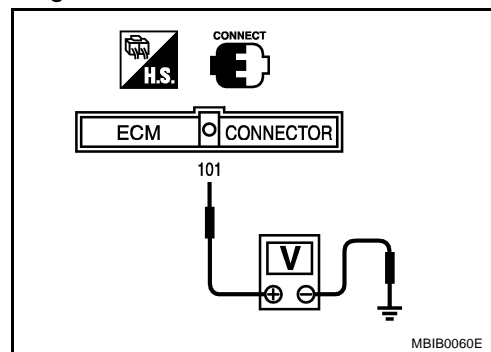

OK or NG

- OK >> GO TO 13.
- NG >> GO TO 8.

3. CHECK ASCD BRAKE SWITCH POWER SUPPLY CIRCUIT

1. Turn ignition switch OFF.
2. Disconnect ASCD brake switch harness connector.
3. Turn ignition switch ON.

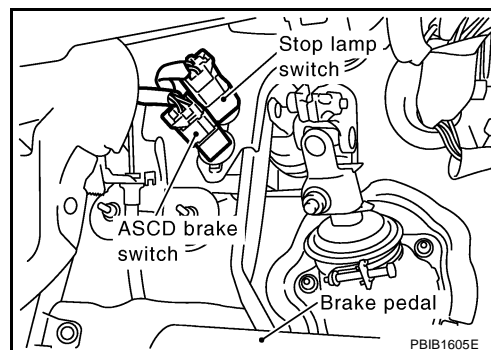

4. Check voltage between ASCD brake switch terminal 1 and ground with CONSULT-II or tester.

Voltage: Battery voltage

OK or NG

- OK >> GO TO 5.
- NG >> GO TO 4.

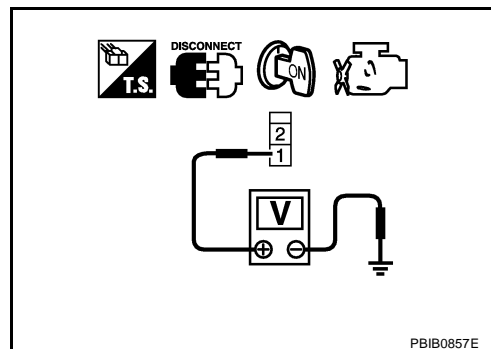

4. DETECT MALFUNCTIONING PART

Check the following.

- Fuse block (J/B) connector E201
- 10A fuse
- Harness for open or short between ASCD brake switch and fuse

>> Repair open circuit or short to ground in harness or connectors.

5. CHECK ASCD BRAKE SWITCH INPUT SIGNAL CIRCUIT FOR OPEN AND SHORT

1. Turn ignition switch OFF.
2. Disconnect ECM harness connector.
3. Check harness continuity between ECM terminal 108 and ASCD brake switch terminal 2. Refer to Wiring Diagram.

Continuity should exist.

4. Also check harness for short to ground and short to power.

OK or NG

- OK >> GO TO 7.
- NG >> GO TO 6.

6. DETECT MALFUNCTIONING PART

Check the following.

- Harness connectors E211, M41
- Harness for open or short between ECM and ASCD brake switch

>> Repair open circuit or short to ground in harness or connectors.

7. CHECK ASCD BRAKE SWITCH

Refer to [EC-540, "Component Inspection"](#)

OK or NG

- OK >> GO TO 13.
 NG >> Replace ASCD brake switch.

8. CHECK STOP LAMP SWITCH POWER SUPPLY CIRCUIT

- Turn ignition switch OFF.
- Disconnect stop lamp switch harness connector.

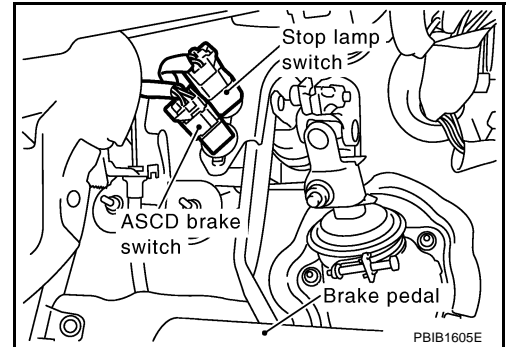

- Check voltage between stop lamp switch terminal 1 and ground with CONSULT-II or tester.

Voltage: Battery voltage

OK or NG

- OK >> GO TO 10.
 NG >> GO TO 9.

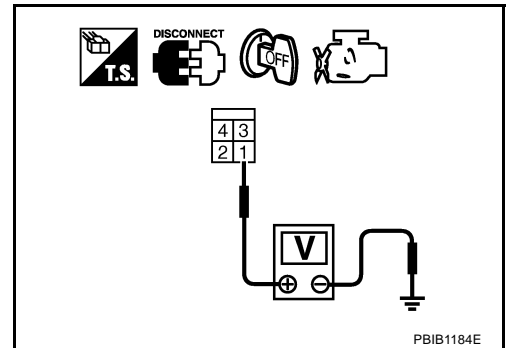

9. DETECT MALFUNCTIONING PART

Check the following.

- Fuse block (J/B) connector E201
- 10A fuse
- Joint connector-2
- Harness for open or short between stop lamp switch and battery

>> Repair open circuit or short to ground or short to power in harness or connectors.

10. CHECK STOP LAMP SWITCH INPUT SIGNAL CIRCUIT FOR OPEN AND SHORT

- Disconnect ECM harness connector.
- Check harness continuity between ECM terminal 101 and stop lamp switch terminal 2. Refer to Wiring Diagram.

Continuity should exist.

- Also check harness for short to ground and short to power.

OK or NG

- OK >> GO TO 12.
 NG >> GO TO 11.

11. DETECT MALFUNCTIONING PART

Check the following.

- Harness connectors E211, M41
- Joint connector-2
- Harness for open or short between ECM and stop lamp switch

>> Repair open circuit or short to ground or short to power in harness or connectors.

12. CHECK STOP LAMP SWITCH

Refer to [EC-540, "Component Inspection"](#)

OK or NG

OK >> GO TO 13.

NG >> Replace stop lamp switch.

13. CHECK INTERMITTENT INCIDENT

Refer to [EC-135, "TROUBLE DIAGNOSIS FOR INTERMITTENT INCIDENT"](#) .

>> **INSPECTION END**

A

EC

C

D

E

F

G

H

I

J

K

L

M

Component Inspection ASCD BRAKE SWITCH

1. Turn ignition switch OFF.
2. Disconnect ASCD brake switch harness connector.
3. Check harness continuity between ASCD brake switch terminals 1 and 2 under the following conditions.

Condition	Continuity
When brake pedal is fully released.	Should exist.
When brake pedal is slightly depressed.	Should not exist.

If NG, adjust ASCD brake switch installation, refer to [BR-6](#), "[BRAKE PEDAL](#)", and perform step 3 again.

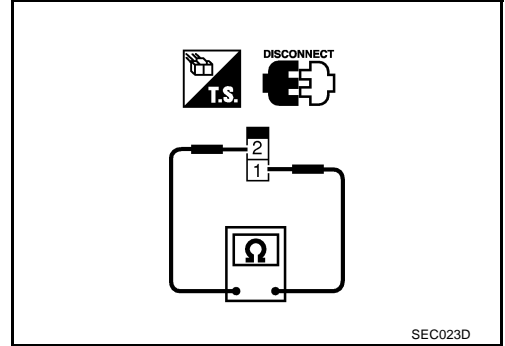

STOP LAMP SWITCH

1. Turn ignition switch OFF.
2. Disconnect stop lamp switch harness connector.
3. Check harness continuity between stop lamp switch terminals 1 and 2 under the following conditions.

Condition	Continuity
When brake pedal is fully released.	Should not exist.
When brake pedal is slightly depressed.	Should exist.

If NG, adjust stop lamp switch installation, refer to [BR-6](#), "[BRAKE PEDAL](#)", and perform step 3 again.

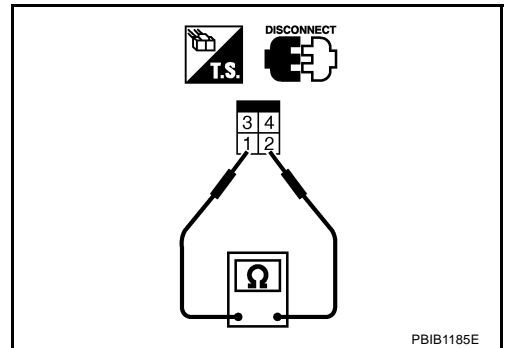

DTC P1574 ICC VEHICLE SPEED SENSOR

PFP:31036

Component Description

ABS007ZD

The ECM receives two vehicle speed signals via CAN communication line. One is sent from “unified meter and A/C amp.”, and the other is from TCM (Transmission control module). The ECM uses these signals for ICC control. Refer to [ACS-6, "DESCRIPTION"](#) for ICC functions.

On Board Diagnosis Logic

ABS007ZE

- This self-diagnosis has the one trip detection logic.
- The MIL will not light up for this self-diagnosis.

NOTE:

- If DTC P1574 is displayed with DTC U1000, U1001, first perform the trouble diagnosis for DTC U1000, U1001. Refer to [EC-142](#) .
- If DTC P1574 is displayed with DTC P0500, first perform the trouble diagnosis for DTC P0500. Refer to [EC-390](#) .
- If DTC P1574 is displayed with DTC P0605, first perform the trouble diagnosis for DTC P0605. Refer to [EC-401](#) .

DTC No.	Trouble Diagnosis Name	DTC Detecting Condition	Possible Cause
P1574 1574	ICC vehicle speed sensor	ECM detects a difference between two vehicle speed signals is out of the specified range.	<ul style="list-style-type: none"> ● Harness or connectors (The CAN communication line is open or shorted.) ● Unified meter and A/C amp. ● ABS actuator and electric unit (control unit) ● Wheel sensor ● TCM ● ECM

DTC Confirmation Procedure

ABS007ZF

CAUTION:

Always drive vehicle at a safe speed.

NOTE:

If DTC Confirmation Procedure has been previously conducted, always turn ignition switch OFF and wait at least 10 seconds before conducting the next test.

TESTING CONDITION:

Step 3 may be conducted with the drive wheels lifted in the shop or by driving the vehicle. If a road test is expected to be easier, it is unnecessary to lift the vehicle.

WITH CONSULT-II

1. Start engine.
2. Select “DATA MONITOR” mode with CONSULT-II.
3. Drive the vehicle at more than 40 km/h (25MPH).
4. If DTC is detected, go to [EC-542, "Diagnostic Procedure"](#) .

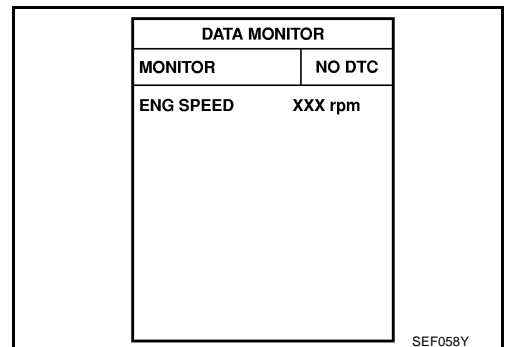

WITH GST

Follow the procedure “WITH CONSULT-II” above.

Diagnostic Procedure

ABS007ZG

1. CHECK DTC WITH TCM

Check DTC with TCM. Refer to [AT-38, "ON BOARD DIAGNOSTIC \(OBD\) SYSTEM"](#) .

OK or NG

OK >> GO TO 2.

NG >> Perform trouble shooting relevant to DTC indicated.

2. CHECK DTC WITH "ABS ACTUATOR AND ELECTRIC UNIT (CONTROL UNIT)"

Refer to [BRC-12, "TROUBLE DIAGNOSIS"](#) .

OK or NG

OK >> GO TO 3.

NG >> Repair or replace.

3. CHECK DTC WITH "UNIFIED METER AND A/C AMP."

Refer to [DI-4, "COMBINATION METERS"](#) .

>> **INSPECTION END**

DTC P1574 ASCD VEHICLE SPEED SENSOR

PFP:31036

Component Description

ABS006WQ

The ECM receives two vehicle speed sensor signals via CAN communication line. One is sent from “unified meter and A/C amp.”, and the other is from TCM (Transmission control module). The ECM uses these signals for ASCD control. Refer to [EC-657, "AUTOMATIC SPEED CONTROL DEVICE \(ASCD\)"](#) for ASCD functions.

On Board Diagnosis Logic

ABS006WR

**This self-diagnosis has the one trip detection logic.
The MIL will not light up for this diagnosis.**

NOTE:

- If DTC P1574 is displayed with DTC U1000, U1001, first perform the trouble diagnosis for DTC U1000, U1001. Refer to [EC-142](#) .
- If DTC P1574 is displayed with DTC P0500, first perform the trouble diagnosis for DTC P0500. Refer to [EC-390](#)
- If DTC P1574 is displayed with DTC P0605, first perform the trouble diagnosis for DTC P0605. Refer to [EC-401](#)

DTC No.	Trouble Diagnosis Name	DTC Detecting Condition	Possible Cause
P1574 1574	ASCD vehicle speed sensor	ECM detects a difference between two vehicle speed signals is out of the specified range.	<ul style="list-style-type: none"> ● Harness or connectors (The CAN communication line is open or shorted.) ● Unified meter and A/C amp. ● ABS actuator and electric unit (control unit) ● Wheel sensor ● TCM ● ECM

DTC Confirmation Procedure

ABS006WS

CAUTION:

Always drive vehicle at a safe speed.

NOTE:

If DTC Confirmation Procedure has been previously conducted, always turn ignition switch OFF and wait at least 10 seconds before conducting the next test.

TESTING CONDITION:

Step 3 may be conducted with the drive wheels lifted in the shop or by driving the vehicle. If a road test is expected to be easier, it is unnecessary to lift the vehicle.

Ⓟ WITH CONSULT-II

1. Start engine.
2. Select “DATA MONITOR” mode with CONSULT-II.
3. Drive the vehicle at more than 40 km/h (25 MPH).
4. If DTC is detected, go to [EC-544, "Diagnostic Procedure"](#) .

DATA MONITOR	
MONITOR	NO DTC
ENG SPEED	XXX rpm

SEF058Y

Ⓢ WITH GST

Follow the procedure “WITH CONSULT-II” above.

Diagnostic Procedure

ABS006WT

1. CHECK DTC WITH TCM

Check DTC with TCM. Refer to [AT-38, "ON BOARD DIAGNOSTIC \(OBD\) SYSTEM"](#) .

OK or NG

OK >> GO TO 2.

NG >> Perform trouble shooting relevant to DTC indicated.

2. CHECK DTC WITH "ABS ACTUATOR AND ELECTRIC UNIT (CONTROL UNIT)"

Refer to [BRC-12, "TROUBLE DIAGNOSIS"](#) .

OK or NG

OK >> GO TO 3.

NG >> Repair or replace.

3. CHECK DTC WITH "UNIFIED METER AND A/C AMP."

Refer to [DI-4, "COMBINATION METERS"](#) .

>> **INSPECTION END**

DTC P1706 PNP SWITCH

PFP:32006

Component Description

ABS006WU

When the gear position is P or N, park/neutral position (PNP) switch is ON.
ECM detects the position because the continuity of the line (the ON signal) exists.

CONSULT-II Reference Value in Data Monitor Mode

ABS006WV

Specification data are reference values.

MONITOR ITEM	CONDITION	SPECIFICATION
P/N POSI SW	● Ignition switch: ON	ON
	Shift lever: Except above	OFF

On Board Diagnosis Logic

ABS006WW

DTC No.	Trouble diagnosis name	DTC detecting condition	Possible cause
P1706 1706	Park/neutral position switch	The signal of the park/neutral position (PNP) switch is not changed in the process of engine starting and driving.	<ul style="list-style-type: none"> ● Harness or connectors [The park/neutral position (PNP) switch circuit is open or shorted.] ● Park/neutral position (PNP) switch ● Unified meter and A/C amp. ● TCM

DTC Confirmation Procedure

ABS006WX

CAUTION:

Always drive vehicle at a safe speed.

NOTE:

If DTC Confirmation Procedure has been previously conducted, always turn ignition switch OFF and wait at least 10 seconds before conducting the next test.

WITH CONSULT-II

1. Turn ignition switch ON.
2. Select "P/N POSI SW" in "DATA MONITOR" mode with CONSULT-II. Then check the "P/N POSI SW" signal under the following conditions.

Position (Selector lever)	Known-good signal
P or N position	ON
Except above position	OFF

If NG, go to [EC-548, "Diagnostic Procedure"](#) .
If OK, go to following step.

3. Select "DATA MONITOR" mode with CONSULT-II.
4. Start engine and warm it up to normal operating temperature.
5. Maintain the following conditions for at least 60 consecutive seconds.

ENG SPEED	1,000 - 6,375 rpm
COOLAN TEMP/S	More than 70°C (158°F)
B/FUEL SCHDL	2.0 - 31.8 msec
VHCL SPEED SE	More than 64 km/h (40 MPH)
Selector lever	Suitable position

6. If 1st trip DTC is detected, go to [EC-548, "Diagnostic Procedure"](#)

DATA MONITOR	
MONITOR	NO DTC
P/N POSI SW	ON

SEF212Y

DATA MONITOR	
MONITOR	NO DTC
ENG SPEED	XXX rpm
COOLAN TEMP/S	XXX °C
VHCL SPEED SE	XXX km/h
P/N POSI SW	OFF
B/FUEL SCHDL	XXX msec

SEF213Y

Overall Function Check

Use this procedure to check the overall function of the park/neutral position (PNP) switch circuit. During this check, a 1st trip DTC might not be confirmed.

 **WITH GST**

1. Turn ignition switch ON.
2. Check voltage between ECM terminal 102 (PNP switch signal) and ground under the following conditions.

Condition (Gear position)	Voltage V (Known-good data)
P or N position	Approx. 0
Except above position	BATTERY VOLTAGE (11 - 14V)

3. If NG, go to [EC-548, "Diagnostic Procedure"](#) .

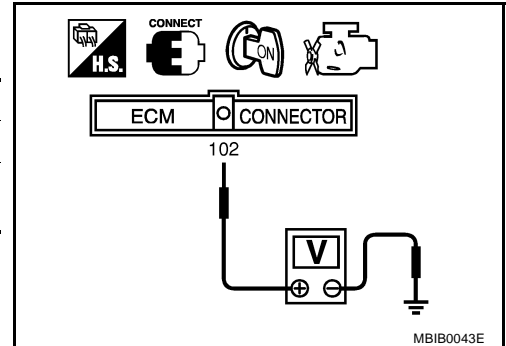



DTC P1706 PNP SWITCH

[VQ35DE]

ABS006WZ

Wiring Diagram

EC-PNP/SW-01

 : DETECTABLE LINE FOR DTC
 : NON-DETECTABLE LINE FOR DTC

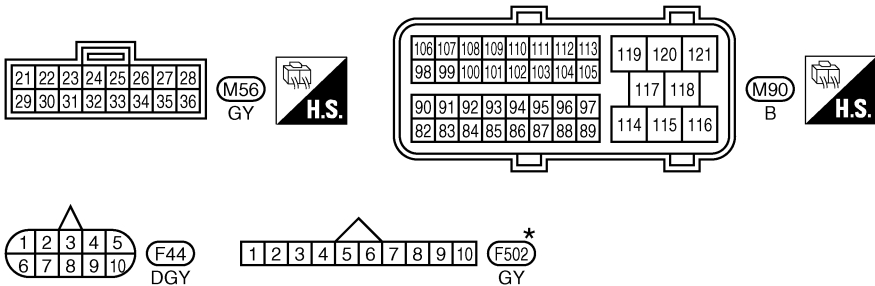
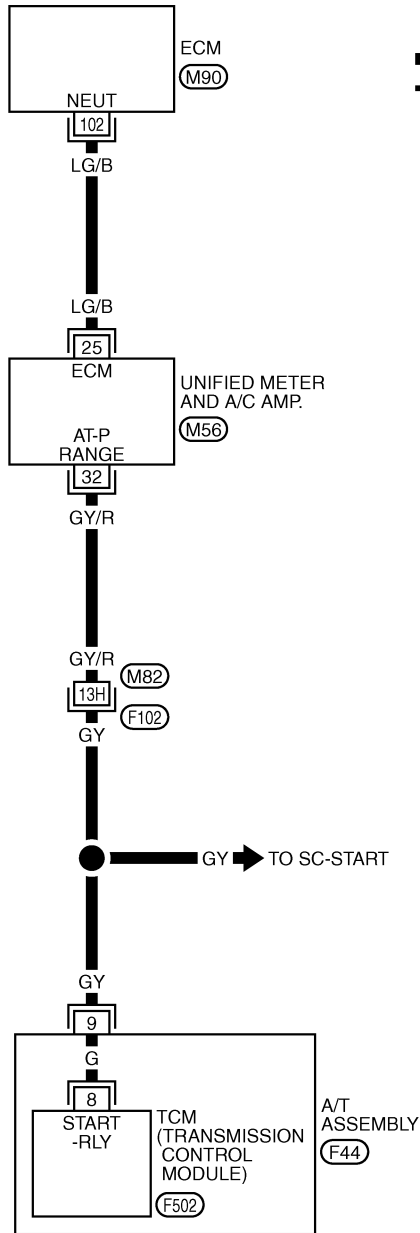

REFER TO THE FOLLOWING.
F102 -SUPER MULTIPLE JUNCTION (SMJ)

*: THIS CONNECTOR IS NOT SHOWN IN "HARNES LAYOUT", PG SECTION.

TBWM0521E

DTC P1706 PNP SWITCH

[VQ35DE]

Specification data are reference values and are measured between each terminal and ground.

CAUTION:

Do not use ECM ground terminals when measuring input/output voltage. Doing so may result in damage to the ECM's transistor. Use a ground other than ECM terminals, such as the ground.

TER-MINAL NO.	WIRE COLOR	ITEM	CONDITION	DATA (DC Voltage)
102	LG/B	PNP switch	[Ignition switch: ON] ● Shift lever: P or N	Approximately 0V
			[Ignition switch: ON] ● Except above position	BATTERY VOLTAGE (11 - 14V)

Diagnostic Procedure

ABS006X0

1. CHECK DTC WITH TCM

Refer to [AT-38, "OBD-II Diagnostic Trouble Code \(DTC\)"](#) .

OK or NG

- OK >> GO TO 2.
- NG >> Repair or replace.

2. CHECK STARTING SYSTEM

Turn ignition switch OFF, then turn it to START.

Does starter motor operate?

Yes or No

- Yes >> GO TO 3.
- No >> Refer to [SC-10, "STARTING SYSTEM"](#) .

3. CHECK PNP SWITCH INPUT SIGNAL CIRCUIT FOR OPEN AND SHORT-I

1. Turn ignition switch OFF.
2. Disconnect A/T assembly harness connector.
3. Disconnect "unified meter and A/C amp." harness connector.
4. Check harness continuity between A/T assembly terminal 9 and "unified meter and A/C amp." terminal 32. Refer to Wiring Diagram.

Continuity should exist.

5. Also check harness for short to ground and short to power.

OK or NG

- OK >> GO TO 5.
- NG >> GO TO 4.

4. DETECT MALFUNCTIONING PART

Check the following.

- Harness connectors F102, M82
- Harness for open or short between A/T assembly and "unified meter and A/C amp."

>> Repair open circuit or short to ground or short to power in harness or connectors.

5. CHECK PNP SWITCH INPUT SIGNAL CIRCUIT FOR OPEN AND SHORT-II

1. Disconnect ECM harness connector.
2. Check harness continuity between ECM terminal 102 and “unified meter and A/C amp.” terminal 25. Refer to Wiring Diagram.

Continuity should exist.

3. Also check harness for short to ground and short to power.

OK or NG

OK >> GO TO 6.

NG >> Repair open circuit or short to ground or short to power in harness or connectors.

6. CHECK PNP SWITCH INPUT SIGNAL CIRCUIT FOR OPEN AND SHORT-III

1. Check harness continuity between A/T assembly terminal 9 and TCM terminal 8. Refer to [AT-108, "DTC P0615 START SIGNAL CIRCUIT"](#) .

Continuity should exist.

2. Also check harness for short to ground and short to power.

OK or NG

OK >> GO TO 7.

NG >> Repair open circuit or short to ground or short to power in harness or connectors.

7. CHECK INTERMITTENT INCIDENT

Refer to [EC-135, "TROUBLE DIAGNOSIS FOR INTERMITTENT INCIDENT"](#) .

OK or NG

OK >> GO TO 8.

NG >> Repair or replace.

8. REPLACE “UNIFIED METER AND A/C AMP.”

Refer to [DI-4, "COMBINATION METERS"](#) .

>> INSPECTION END

A

EC

C

D

E

F

G

H

I

J

K

L

M

DTC P1805 BRAKE SWITCH

PFP:25320

Description

ABS006X1

Brake switch signal is applied to the ECM through the stop lamp switch when the brake pedal is depressed. This signal is used mainly to decrease the engine speed when the vehicle is driving.

CONSULT-II Reference Value in Data Monitor Mode

ABS006X2

Specification data are reference values.

MONITOR ITEM	CONDITION	SPECIFICATION
BRAKE SW	● Ignition switch: ON	Brake pedal: Fully released OFF
		Brake pedal: Slightly depressed ON

On Board Diagnosis Logic

ABS006X3

The MIL will not light up for this diagnosis.

DTC No.	Trouble diagnosis name	DTC detecting condition	Possible cause
P1805 1805	Brake switch	A brake switch signal is not sent to ECM for extremely long time while the vehicle is driving.	<ul style="list-style-type: none"> ● Harness or connectors (Stop lamp switch circuit is open or shorted.) ● Stop lamp switch

FAIL-SAFE MODE

When the malfunction is detected, the ECM enters fail-safe mode.

Engine operating condition in fail-safe mode

ECM controls the electric throttle control actuator by regulating the throttle opening to a small range. Therefore, acceleration will be poor.

Vehicle condition	Driving condition
When engine is idling	Normal
When accelerating	Poor acceleration

DTC Confirmation Procedure

ABS006X4

NOTE:

If DTC Confirmation Procedure has been previously conducted, always turn ignition switch OFF and wait at least 10 seconds before conducting the next test.

WITH CONSULT-II

1. Turn ignition switch ON.
2. Fully depress the brake pedal for at least 5 seconds.
3. Erase the DTC with CONSULT-II.
4. Select "DATA MONITOR" mode with CONSULT-II.
5. If 1st trip DTC is detected, go to [EC-552. "Diagnostic Procedure"](#)

DATA MONITOR	
MONITOR	NO DTC
ENG SPEED	XXX rpm

SEF058Y

WITH GST

Follow the procedure "WITH CONSULT-II" above.

DTC P1805 BRAKE SWITCH

[VQ35DE]

Wiring Diagram

ABS006X5

EC-BRK/SW-01

— : DETECTABLE LINE FOR DTC
 - - - : NON-DETECTABLE LINE FOR DTC

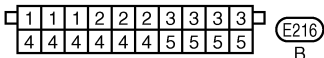
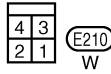
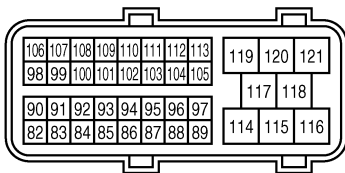
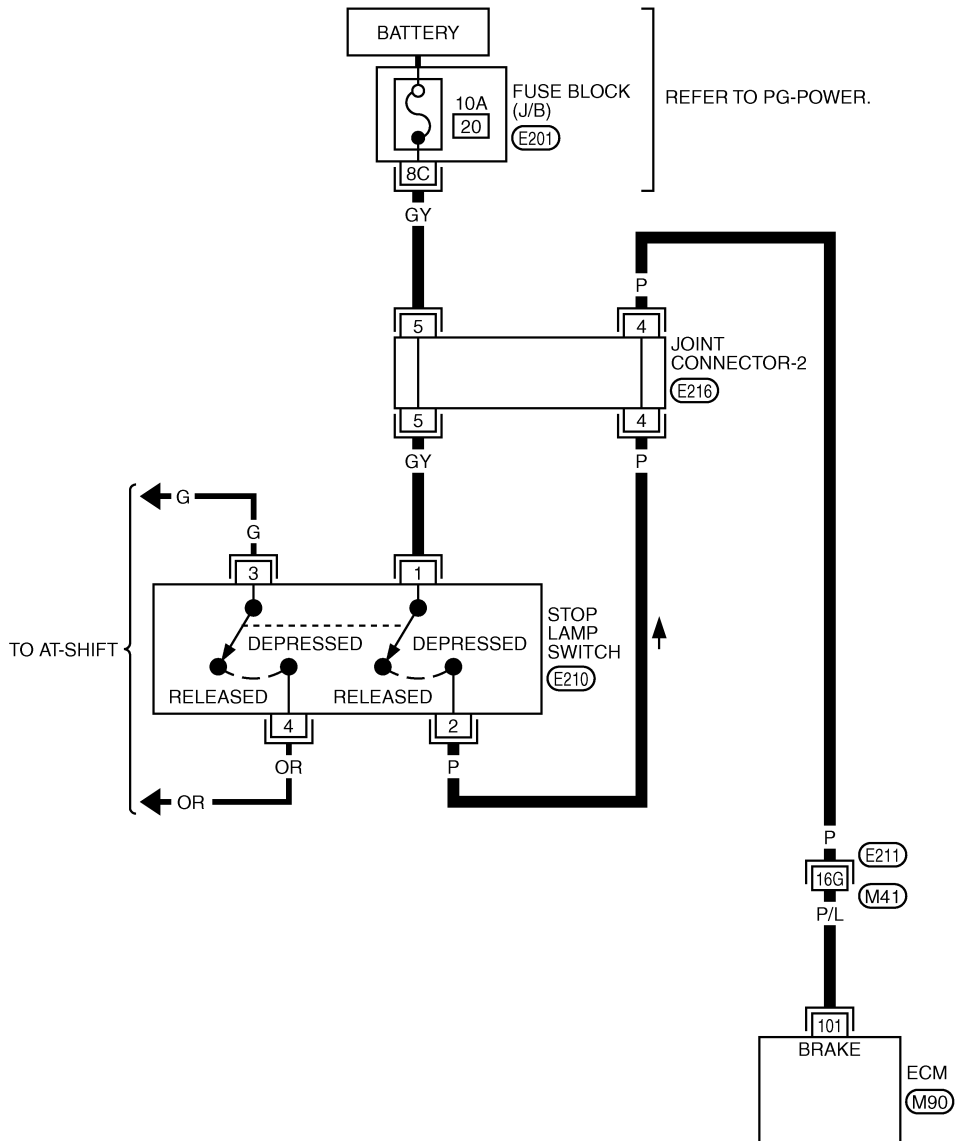

REFER TO THE FOLLOWING.

(E21) -SUPER MULTIPLE JUNCTION (SMJ)

(E20) -FUSE BLOCK-JUNCTION BOX (J/B)

TBWM0260E

DTC P1805 BRAKE SWITCH

[VQ35DE]

Specification data are reference values and are measured between each terminal and ground.

CAUTION:

Do not use ECM ground terminals when measuring input/output voltage. Doing so may result in damage to the ECM's transistor. Use a ground other than ECM terminals, such as the ground.

TER-MINAL NO.	WIRE COLOR	ITEM	CONDITION	DATA (DC Voltage)
101	P/L	Stop lamp switch	[Ignition switch: OFF] ● Brake pedal: Fully released	Approximately 0V
			[Ignition switch: OFF] ● Brake pedal: Slightly depressed	BATTERY VOLTAGE (11 - 14V)

Diagnostic Procedure

ABS006X6

1. CHECK STOP LAMP SWITCH CIRCUIT

1. Turn ignition switch OFF.
2. Check the stop lamp when depressing and releasing the brake pedal.

Brake pedal	Stop lamp
Fully released	Not illuminated
Slightly depressed	Illuminated

OK or NG

- OK >> GO TO 4.
- NG >> GO TO 2.

2. CHECK STOP LAMP SWITCH POWER SUPPLY CIRCUIT

1. Disconnect stop lamp switch harness connector.

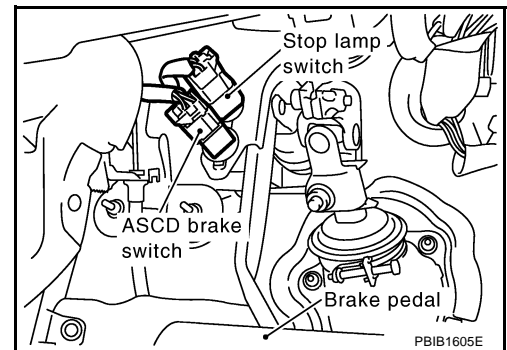

2. Check voltage between stop lamp switch terminal 1 and ground with CONSULT-II or tester.

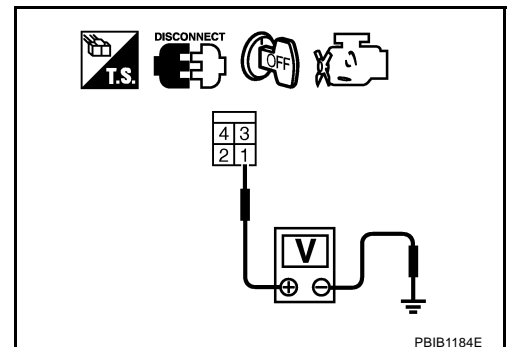

Voltage: Battery voltage

OK or NG

- OK >> GO TO 4.
- NG >> GO TO 3.

3. DETECT MALFUNCTIONING PART

Check the following.

- 10A fuse
- Fuse block (J/B) connector E201
- Joint connector-2
- Harness for open and short between stop lamp switch and battery

>> Repair open circuit or short to ground or short to power in harness or connectors.

4. CHECK STOP LAMP SWITCH INPUT SIGNAL CIRCUIT FOR OPEN AND SHORT

1. Turn ignition switch OFF.
2. Disconnect ECM harness connector.
3. Disconnect stop lamp switch harness connector.
4. Check harness continuity between ECM terminal 101 and stop lamp switch terminal 2.
Refer to Wiring Diagram.

Continuity should exist.

5. Also check harness for short to ground and short to power.

OK or NG

- OK >> GO TO 6.
NG >> GO TO 5.

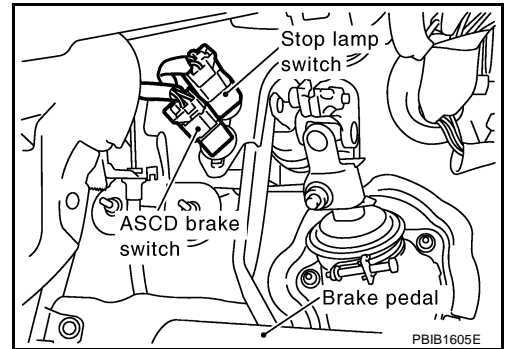

5. DETECT MALFUNCTIONING PART

Check the following.

- Harness connectors E211, M41
- Joint connector-2
- Harness for open or short between ECM and stop lamp switch

>> Repair open circuit or short to ground or short to power in harness or connectors.

6. CHECK STOP LAMP SWITCH

Refer to [EC-554, "Component Inspection"](#).

OK or NG

- OK >> GO TO 7.
NG >> Replace stop lamp switch.

7. CHECK INTERMITTENT INCIDENT

Refer to [EC-135, "TROUBLE DIAGNOSIS FOR INTERMITTENT INCIDENT"](#).

>> **INSPECTION END**

Component Inspection STOP LAMP SWITCH

1. Disconnect stop lamp switch harness connector.

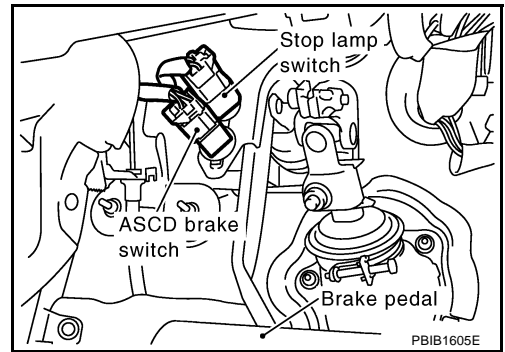

2. Check continuity between stop lamp switch terminals 1 and 2 under the following conditions.

Conditions	Continuity
Brake pedal is fully released	Should not exist.
Brake pedal is slightly depressed	Should exist.

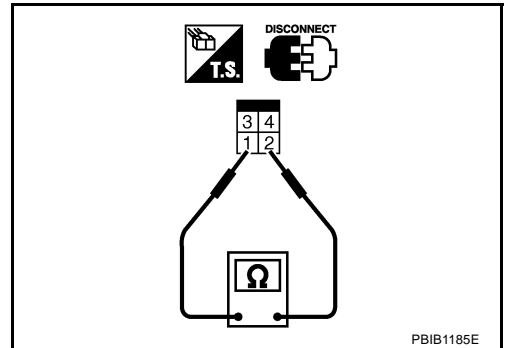

3. If NG, adjust stop lamp switch installation, refer to [BR-6, "BRAKE PEDAL"](#) , and perform step 2 again.

DTC P2122, P2123 APP SENSOR

PPF:18002

Component Description

ABS006X8

The accelerator pedal position sensor is installed on the upper end of the accelerator pedal assembly. The sensor detects the accelerator position and sends a signal to the ECM.

Accelerator pedal position sensor has two sensors. These sensors are a kind of potentiometers which transform the accelerator pedal position into output voltage, and emit the voltage signal to the ECM. In addition, these sensors detect the opening and closing speed of the accelerator pedal and feed the voltage signals to the ECM. The ECM judges the current opening angle of the accelerator pedal from these signals and controls the throttle control motor based on these signals.

Idle position of the accelerator pedal is determined by the ECM receiving the signal from the accelerator pedal position sensor. The ECM uses this signal for the engine operation such as fuel cut.

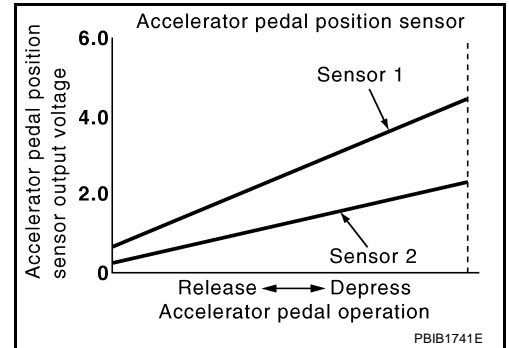

CONSULT-II Reference Value in Data Monitor Mode

ABS006X9

Specification data are reference values.

MONITOR ITEM	CONDITION		SPECIFICATION
ACCEL SEN1	● Ignition switch: ON (Engine stopped)	Accelerator pedal: Fully released	0.5 - 1.0V
		Accelerator pedal: Fully depressed	4.0 - 4.8V
ACCEL SEN2*	● Ignition switch: ON (Engine stopped)	Accelerator pedal: Fully released	0.3 - 1.2V
		Accelerator pedal: Fully depressed	3.9 - 4.8V
CLSD THL POS	● Ignition switch: ON (Engine stopped)	Accelerator pedal: Fully released	ON
		Accelerator pedal: Slightly depressed	OFF

*: Accelerator pedal position sensor 2 signal is converted by ECM internally. Thus, it differs from ECM terminal voltage.

On Board Diagnosis Logic

ABS006XA

These self-diagnoses have the one trip detection logic.

NOTE:

If DTC P2122 or P2123 is displayed with DTC P1229, first perform the trouble diagnosis for DTC P1229. Refer to [EC-489, "DTC P1229 SENSOR POWER SUPPLY"](#).

DTC No.	Trouble diagnosis name	DTC detecting condition	Possible cause
P2122 2122	Accelerator pedal position sensor 1 circuit low input	An excessively low voltage from the APP sensor 1 is sent to ECM.	● Harness or connectors (The APP sensor 1 circuit is open or shorted.) ● Accelerator pedal position sensor (Accelerator pedal position sensor 1)
P2123 2123	Accelerator pedal position sensor 1 circuit high input	An excessively high voltage from the APP sensor 1 is sent to ECM.	

FAIL-SAFE MODE

When the malfunction is detected, ECM enters fail-safe mode and the MIL lights up.

Engine operating condition in fail-safe mode

The ECM controls the electric throttle control actuator in regulating the throttle opening in order for the idle position to be within +10 degrees.

The ECM regulates the opening speed of the throttle valve to be slower than the normal condition.

So, the acceleration will be poor.

DTC Confirmation Procedure

NOTE:

If DTC Confirmation Procedure has been previously conducted, always turn ignition switch OFF and wait at least 10 seconds before conducting the next test.

TESTING CONDITION:

Before performing the following procedure, confirm that battery voltage is more than 10V at idle.

 **WITH CONSULT-II**

1. Turn ignition switch ON.
2. Select "DATA MONITOR" mode with CONSULT-II.
3. Start engine and let it idle for 1 second.
4. If DTC is detected, go to [EC-558, "Diagnostic Procedure"](#) .

DATA MONITOR	
MONITOR	NO DTC
ENG SPEED	XXX rpm

SEF058Y

 **WITH GST**

Follow the procedure "WITH CONSULT-II" above.



DTC P2122, P2123 APP SENSOR

[VQ35DE]

Wiring Diagram

ABS006XC

EC-APPS1-01

 : DETECTABLE LINE FOR DTC
 : NON-DETECTABLE LINE FOR DTC

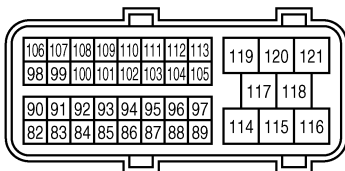
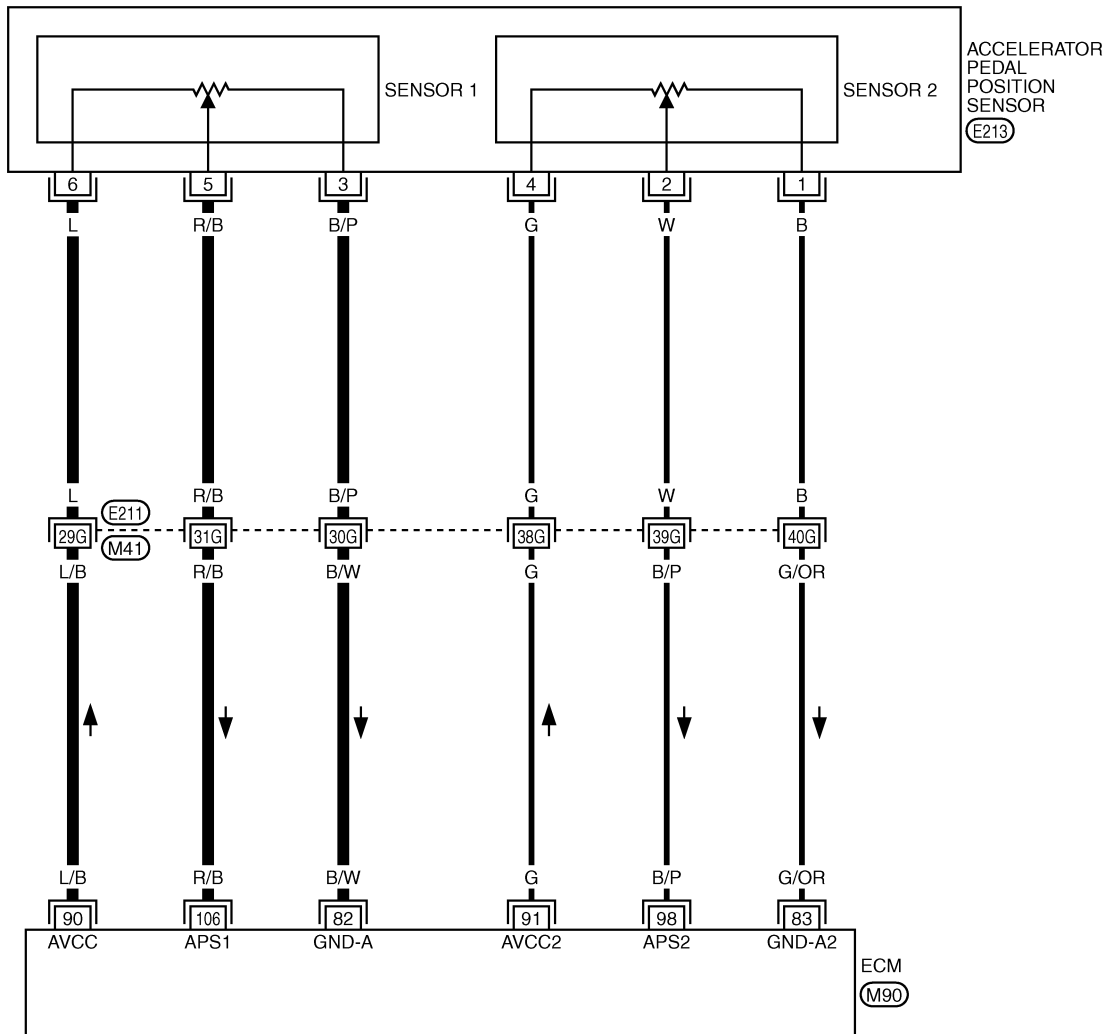

(M90) B

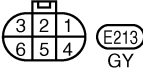

REFER TO THE FOLLOWING.
 (E211) -SUPER MULTIPLE JUNCTION (SMJ)

TBWM0239E

DTC P2122, P2123 APP SENSOR

[VQ35DE]

Specification data are reference values and are measured between each terminal and ground.

CAUTION:

Do not use ECM ground terminals when measuring input/output voltage. Doing so may result in damage to the ECM's transistor. Use a ground other than ECM terminals, such as the ground.

TER-MINAL NO.	WIRE COLOR	ITEM	CONDITION	DATA (DC Voltage)
82	B/W	Sensor ground (APP sensor 1)	[Engine is running] ● Warm-up condition ● Idle speed	Approximately 0V
83	G/OR	Sensor ground (APP sensor 2)	[Engine is running] ● Warm-up condition ● Idle speed	Approximately 0V
90	L/B	Sensor power supply (APP sensor 1)	[Ignition switch: ON]	Approximately 5V
91	G	Sensor power supply (APP sensor 2)	[Ignition switch: ON]	Approximately 5V
98	B/P	Accelerator pedal position sensor 2	[Ignition switch: ON] ● Engine stopped ● Accelerator pedal: Fully released	0.15 - 0.60V
			[Ignition switch: ON] ● Engine stopped ● Accelerator pedal: Fully depressed	1.95 - 2.40V
106	R/B	Accelerator pedal position sensor 1	[Ignition switch: ON] ● Engine stopped ● Accelerator pedal: Fully released	0.5 - 1.0V
			[Ignition switch: ON] ● Engine stopped ● Accelerator pedal: Fully depressed	3.9 - 4.7V

Diagnostic Procedure

ABS00CHU

1. CHECK GROUND CONNECTIONS

1. Turn ignition switch OFF.
2. Loosen and retighten ground three screws on the body. Refer to [EC-141, "Ground Inspection"](#).

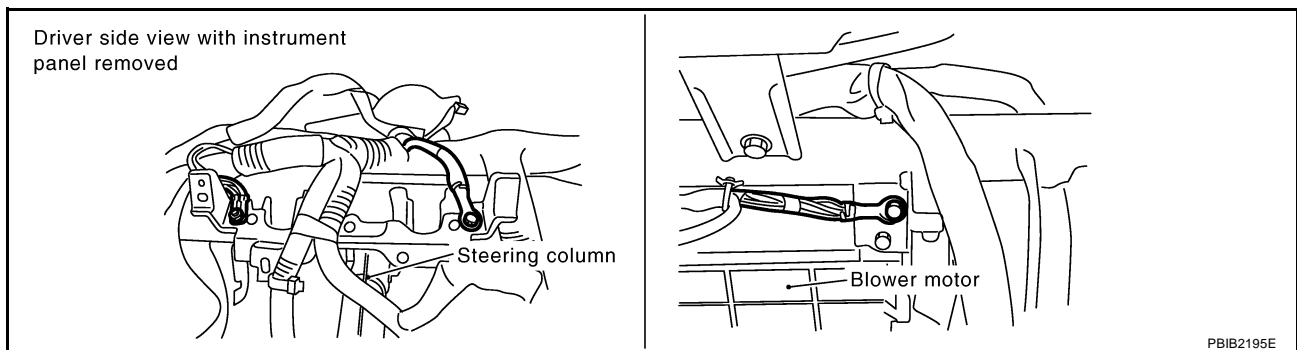

OK or NG

- OK >> GO TO 2.
- NG >> Repair or replace ground connections.

2. CHECK APP SENSOR 1 POWER SUPPLY CIRCUIT

1. Disconnect accelerator pedal position (APP) sensor harness connector.
2. Turn ignition switch ON.

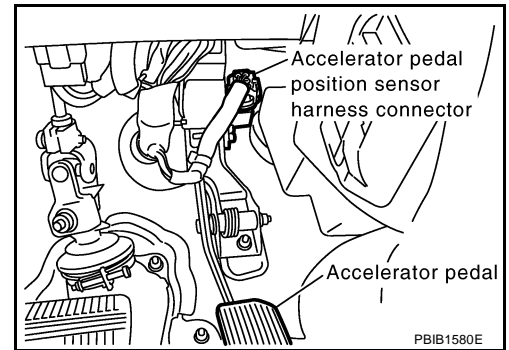

3. Check voltage between APP sensor terminal 6 and ground with CONSULT-II or tester.

Voltage: Approximately 5V

OK or NG

- OK >> GO TO 4.
NG >> GO TO 3.

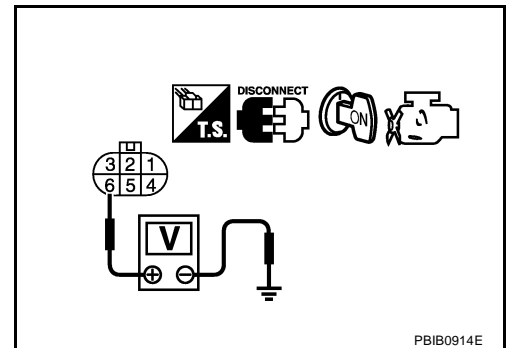

3. DETECT MALFUNCTIONING PART

Check the following.

- Harness connectors E211, M41
- Harness for open or short between ECM and accelerator pedal position sensor

>> Repair open circuit or short to ground or short to power in harness or connectors.

4. CHECK APP SENSOR 1 GROUND CIRCUIT FOR OPEN AND SHORT

1. Turn ignition switch OFF.
2. Disconnect ECM harness connector.
3. Check harness continuity between APP sensor terminal 3 and ECM terminal 82. Refer to Wiring Diagram.

Continuity should exist.

4. Also check harness for short to ground and short to power.

OK or NG

- OK >> GO TO 6.
NG >> GO TO 5.

5. DETECT MALFUNCTIONING PART

Check the following.

- Harness connectors E211, M41
- Harness for open or short between ECM and accelerator pedal position sensor

>> Repair open circuit or short to ground or short to power in harness or connectors.

6. CHECK APP SENSOR INPUT SIGNAL CIRCUIT FOR OPEN AND SHORT

1. Check harness continuity between ECM terminal 106 and APP sensor terminal 5.
Refer to Wiring Diagram.

Continuity should exist.

2. Also check harness for short to ground and short to power.

OK or NG

- OK >> GO TO 8.
- NG >> GO TO 7.

7. DETECT MALFUNCTIONING PART

Check the following.

- Harness connectors E211, M41
- Harness for open or short between ECM and accelerator pedal position sensor

>> Repair open circuit or short to ground or short to power in harness or connectors.

8. CHECK APP SENSOR

Refer to [EC-560, "Component Inspection"](#) .

OK or NG

- OK >> GO TO 10.
- NG >> GO TO 9.

9. REPLACE ACCELERATOR PEDAL ASSEMBLY

1. Replace accelerator pedal assembly.
2. Perform [EC-49, "Accelerator Pedal Released Position Learning"](#) .
3. Perform [EC-49, "Throttle Valve Closed Position Learning"](#) .
4. Perform [EC-49, "Idle Air Volume Learning"](#) .

>> **INSPECTION END**

10. CHECK INTERMITTENT INCIDENT

Refer to [EC-135, "TROUBLE DIAGNOSIS FOR INTERMITTENT INCIDENT"](#) .

>> **INSPECTION END**

**Component Inspection
ACCELERATOR PEDAL POSITION SENSOR**

ABS006XE

1. Reconnect all harness connectors disconnected.
2. Turn ignition switch ON.
3. Check voltage between ECM terminals 106 (APP sensor 1 signal), 98 (APP sensor 2 signal) and ground under the following conditions.

Terminal	Accelerator pedal	Voltage
106 (Accelerator pedal position sensor 1)	Fully released	0.5 - 1.0V
	Fully depressed	3.9 - 4.7V
98 (Accelerator pedal position sensor 2)	Fully released	0.15 - 0.60V
	Fully depressed	1.95 - 2.40V

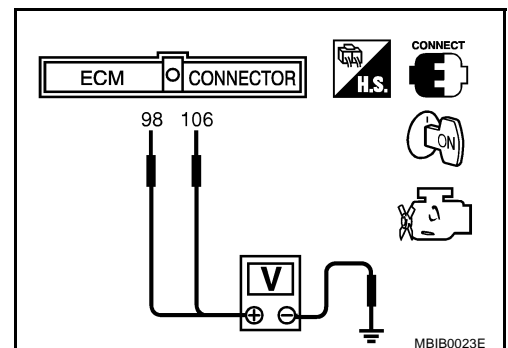

4. If NG, replace accelerator pedal assembly and go to next step.
5. Perform [EC-49, "Accelerator Pedal Released Position Learning"](#) .
6. Perform [EC-49, "Throttle Valve Closed Position Learning"](#) .
7. Perform [EC-49, "Idle Air Volume Learning"](#) .

A

Removal and Installation ACCELERATOR PEDAL

ABS006XF

EC

Refer to [ACC-3, "ACCELERATOR CONTROL SYSTEM"](#) .

C

D

E

F

G

H

I

J

K

L

M

DTC P2127, P2128 APP SENSOR

PFP:18002

Component Description

ABS00CHV

The accelerator pedal position sensor is installed on the upper end of the accelerator pedal assembly. The sensor detects the accelerator position and sends a signal to the ECM.

Accelerator pedal position sensor has two sensors. These sensors are a kind of potentiometers which transform the accelerator pedal position into output voltage, and emit the voltage signal to the ECM. In addition, these sensors detect the opening and closing speed of the accelerator pedal and feed the voltage signals to the ECM. The ECM judges the current opening angle of the accelerator pedal from these signals and controls the throttle control motor based on these signals.

Idle position of the accelerator pedal is determined by the ECM receiving the signal from the accelerator pedal position sensor. The ECM uses this signal for the engine operation such as fuel cut.

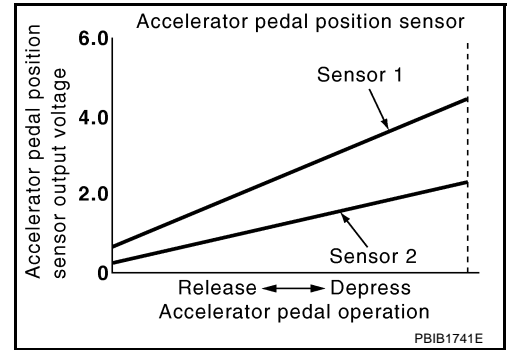

CONSULT-II Reference Value in Data Monitor Mode

ABS00CHW

Specification data are reference values.

MONITOR ITEM	CONDITION	SPECIFICATION
ACCEL SEN1	● Ignition switch: ON (Engine stopped) Accelerator pedal: Fully released	0.5 - 1.0V
	Accelerator pedal: Fully depressed	4.0 - 4.8V
ACCEL SEN2*	● Ignition switch: ON (Engine stopped) Accelerator pedal: Fully released	0.3 - 1.2V
	Accelerator pedal: Fully depressed	3.9 - 4.8V
CLSD THL POS	● Ignition switch: ON (Engine stopped) Accelerator pedal: Fully released	ON
	Accelerator pedal: Slightly depressed	OFF

*: Accelerator pedal position sensor 2 signal is converted by ECM internally. Thus, it differs from ECM terminal voltage.

On Board Diagnosis Logic

ABS00CHX

These self-diagnoses have the one trip detection logic.

DTC No.	Trouble diagnosis name	DTC detecting condition	Possible cause
P2127 2127	Accelerator pedal position sensor 2 circuit low input	An excessively low voltage from the APP sensor 2 is sent to ECM.	<ul style="list-style-type: none"> ● Harness or connectors (The APP sensor 2 circuit is open or shorted.) (TP sensor circuit shorted.) ● Accelerator pedal position sensor (Accelerator pedal position sensor 2) ● Electric throttle control actuator (TP sensor 1 and 2)
P2128 2128	Accelerator pedal position sensor 2 circuit high input	An excessively high voltage from the APP sensor 2 is sent to ECM.	

FAIL-SAFE MODE

When the malfunction is detected, ECM enters fail-safe mode and the MIL lights up.

Engine operating condition in fail-safe mode

The ECM controls the electric throttle control actuator in regulating the throttle opening in order for the idle position to be within +10 degrees.

The ECM regulates the opening speed of the throttle valve to be slower than the normal condition.

So, the acceleration will be poor.

DTC Confirmation Procedure

NOTE:

If DTC Confirmation Procedure has been previously conducted, always turn ignition switch OFF and wait at least 10 seconds before conducting the next test.

TESTING CONDITION:

Before performing the following procedure, confirm that battery voltage is more than 10V at idle.

WITH CONSULT-II

1. Turn ignition switch ON.
2. Select "DATA MONITOR" mode with CONSULT-II.
3. Start engine and let it idle for 1 second.
4. If DTC is detected, go to [EC-565, "Diagnostic Procedure"](#) .

DATA MONITOR	
MONITOR	NO DTC
ENG SPEED	XXX rpm

SEF058Y

WITH GST

Follow the procedure "With CONSULT-II" above.

A
EC
C
D
E
F
G
H
I
J
K
L
M

DTC P2127, P2128 APP SENSOR

[VQ35DE]

ABS00CHZ

Wiring Diagram

EC-APPS2-01

: DETECTABLE LINE FOR DTC
 : NON-DETECTABLE LINE FOR DTC

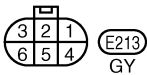
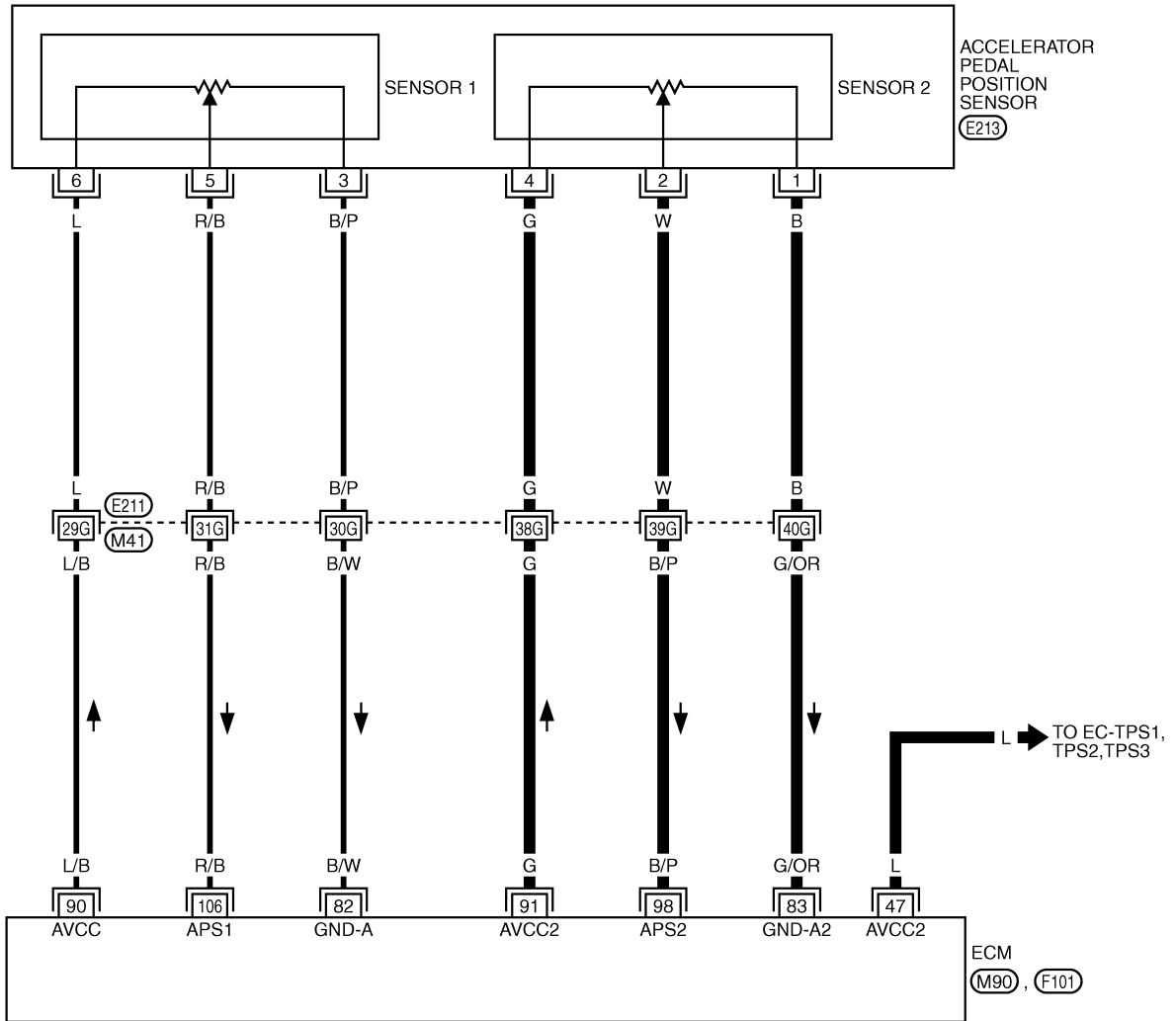

REFER TO THE FOLLOWING.
 (E213) -SUPER MULTIPLE JUNCTION (SMJ)

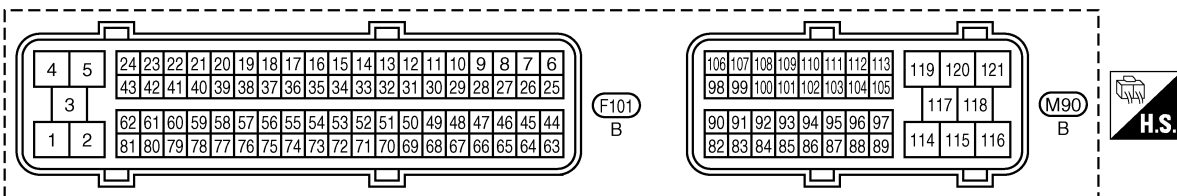

TBWM0506E

DTC P2127, P2128 APP SENSOR

[VQ35DE]

Specification data are reference values and are measured between each terminal and ground.

CAUTION:

Do not use ECM ground terminals when measuring input/output voltage. Doing so may result in damage to the ECM's transistor. Use a ground other than ECM terminals, such as the ground.

TER-MINAL NO.	WIRE COLOR	ITEM	CONDITION	DATA (DC Voltage)
47	L	Sensor power supply (Throttle position sensor)	[Ignition switch: ON]	Approximately 5V
82	B/W	Sensor ground (APP sensor 1)	[Engine is running] ● Warm-up condition ● Idle speed	Approximately 0V
83	G/OR	Sensor ground (APP sensor 2)	[Engine is running] ● Warm-up condition ● Idle speed	Approximately 0V
90	L/B	Sensor power supply (APP sensor 1)	[Ignition switch: ON]	Approximately 5V
91	G	Sensor power supply (APP sensor 2)	[Ignition switch: ON]	Approximately 5V
98	B/P	Accelerator pedal position sensor 2	[Ignition switch: ON] ● Engine stopped ● Accelerator pedal: Fully released	0.15 - 0.60V
			[Ignition switch: ON] ● Engine stopped ● Accelerator pedal: Fully depressed	1.95 - 2.40V
106	R/B	Accelerator pedal position sensor 1	[Ignition switch: ON] ● Engine stopped ● Accelerator pedal: Fully released	0.5 - 1.0V
			[Ignition switch: ON] ● Engine stopped ● Accelerator pedal: Fully depressed	3.9 - 4.7V

Diagnostic Procedure

ABS00C10

1. CHECK GROUND CONNECTIONS

1. Turn ignition switch OFF.
2. Loosen and retighten ground three screws on the body, Refer to [EC-141, "Ground Inspection"](#).

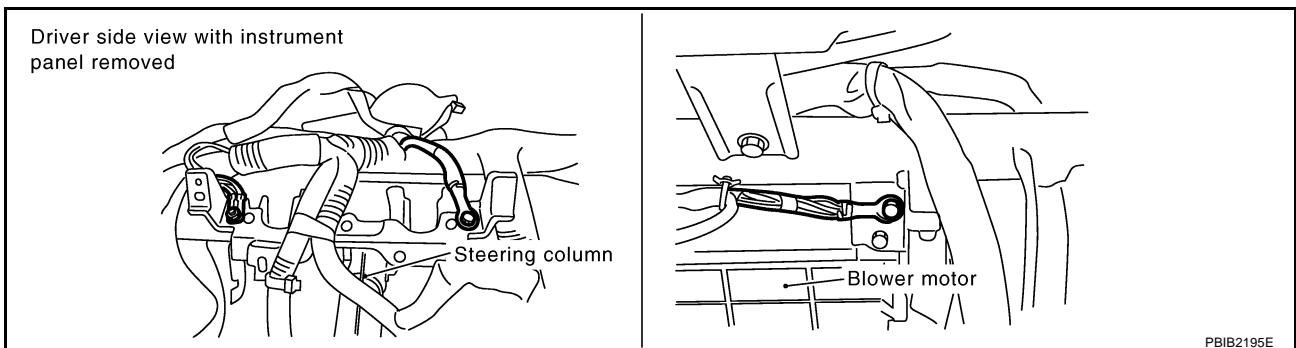

PBIB2195E

OK or NG

- OK >> GO TO 2.
- NG >> Repair or replace ground connections.

2. CHECK APP SENSOR 2 POWER SUPPLY CIRCUIT-I

1. Disconnect accelerator pedal position (APP) sensor harness connector.
2. Turn ignition switch ON.

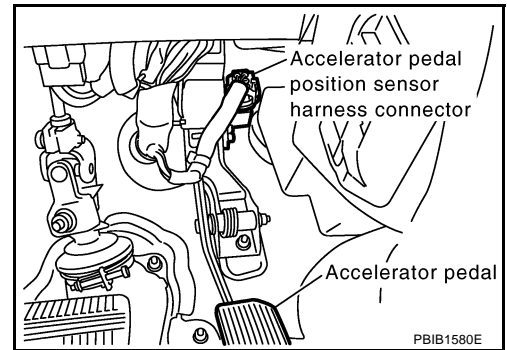

3. Check voltage between APP sensor terminal 4 and ground with CONSULT-II or tester.

Voltage: Approximately 5V

OK or NG

- OK >> GO TO 8.
 NG >> GO TO 3.

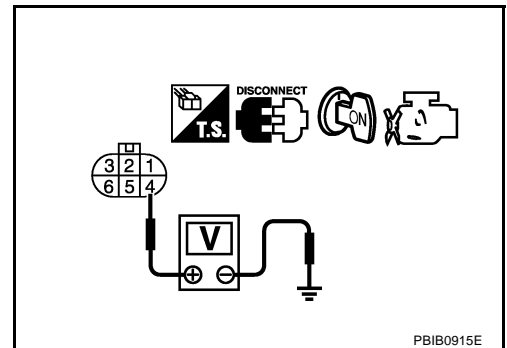

3. CHECK APP SENSOR 2 POWER SUPPLY CIRCUIT-II

1. Turn ignition switch OFF.
2. Disconnect ECM harness connector.
3. Check harness continuity between APP sensor terminal 4 and ECM terminal 91. Refer to wiring diagram.

Continuity should exist.

OK or NG

- OK >> GO TO 5.
 NG >> GO TO 4.

4. DETECT MALFUNCTIONING PART

Check the following.

- Harness connectors E211, M41
- Harness for open or short between ECM and accelerator pedal position sensor

>> Repair open circuit or short to ground or short to power in harness or connectors.

5. CHECK THROTTLE POSITION SENSOR 2 POWER SUPPLY CIRCUIT-III

Check the following.

- Harness for short to power and short to ground, between the following terminals.

ECM terminal	Sensor terminal	Reference Wiring Diagram
91	APP sensor terminal 4	EC-564
47	Electric throttle control actuator terminal 1	EC-192

OK or NG

- OK >> GO TO 6.
 NG >> Repair short to ground or short to power in harness or connectors.

6. CHECK THROTTLE POSITION SENSOR

A

Refer to [EC-575, "Component Inspection"](#) .

OK or NG

- OK >> GO TO 14.
NG >> GO TO 7.

EC

7. REPLACE ELECTRIC THROTTLE CONTROL ACTUATOR

C

1. Replace electric throttle control actuator.
2. Perform [EC-49, "Throttle Valve Closed Position Learning"](#) .
3. Perform [EC-49, "Idle Air Volume Learning"](#) .

D

>> INSPECTION END

E

8. CHECK APP SENSOR 2 GROUND CIRCUIT FOR OPEN AND SHORT

F

1. Turn ignition switch OFF.
2. Disconnect ECM harness connector.
3. Check harness continuity between APP sensor terminal 1 and ECM terminal 83.
Refer to Wiring Diagram.

G

Continuity should exist.

4. Also check harness for short to ground and short to power.

H

OK or NG

- OK >> GO TO 10.
NG >> GO TO 9.

I

9. DETECT MALFUNCTIONING PART

J

Check the following.

- Harness connectors E211, M41
- Harness for open or short between ECM and accelerator pedal position sensor

K

>> Repair open circuit or short to ground or short to power in harness or connectors.

10. CHECK APP SENSOR 2 INPUT SIGNAL CIRCUIT FOR OPEN AND SHORT

L

1. Check harness continuity between ECM terminal 98 and APP sensor terminal 2.
Refer to Wiring Diagram.

M

Continuity should exist.

2. Also check harness for short to ground and short to power.

OK or NG

- OK >> GO TO 12.
NG >> GO TO 11.

11. DETECT MALFUNCTIONING PART

Check the following.

- Harness connectors E211, M41
- Harness for open or short between ECM and accelerator pedal position sensor

>> Repair open circuit or short to ground or short to power in harness or connectors.

12. CHECK APP SENSOR

Refer to [EC-568, "Component Inspection"](#) .

OK or NG

- OK >> GO TO 14.
- NG >> GO TO 13.

13. REPLACE ACCELERATOR PEDAL ASSEMBLY

1. Replace accelerator pedal assembly.
2. Perform [EC-49, "Accelerator Pedal Released Position Learning"](#) .
3. Perform [EC-49, "Throttle Valve Closed Position Learning"](#) .
4. Perform [EC-49, "Idle Air Volume Learning"](#) .

>> INSPECTION END

14. CHECK INTERMITTENT INCIDENT

Refer to [EC-135, "TROUBLE DIAGNOSIS FOR INTERMITTENT INCIDENT"](#) .

>> INSPECTION END

Component Inspection ACCELERATOR PEDAL POSITION SENSOR

ABS00C1

1. Reconnect all harness connectors disconnected.
2. Turn ignition switch ON.
3. Check voltage between ECM terminals 106 (APP sensor 1 signal), 98 (APP sensor 2 signal) and ground under the following conditions.

Terminal	Accelerator pedal	Voltage
106 (Accelerator pedal position sensor 1)	Fully released	0.5 - 1.0V
	Fully depressed	3.9 - 4.7V
98 (Accelerator pedal position sensor 2)	Fully released	0.15 - 0.60V
	Fully depressed	1.95 - 2.40V

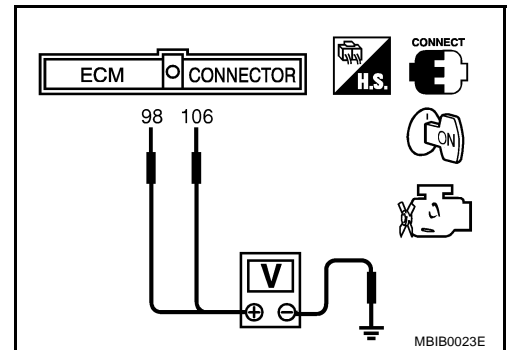

MBIB0023E

4. If NG, replace accelerator pedal assembly and go to next step.
5. Perform [EC-49, "Accelerator Pedal Released Position Learning"](#) .
6. Perform [EC-49, "Throttle Valve Closed Position Learning"](#) .
7. Perform [EC-49, "Idle Air Volume Learning"](#) .

Removal and Installation ACCELERATOR PEDAL

ABS00C2

Refer to [ACC-3, "ACCELERATOR CONTROL SYSTEM"](#) .

DTC P2135 TP SENSOR

Component Description

ABS00C3

Electric throttle control actuator consists of throttle control motor, throttle position sensor, etc. The throttle position sensor responds to the throttle valve movement.

The throttle position sensor has the two sensors. These sensors are a kind of potentiometers which transform the throttle valve position into output voltage, and emit the voltage signal to the ECM. In addition, these sensors detect the opening and closing speed of the throttle valve and feed the voltage signals to the ECM. The ECM judges the current opening angle of the throttle valve from these signals and the ECM controls the throttle control motor to make the throttle valve opening angle properly in response to driving condition.

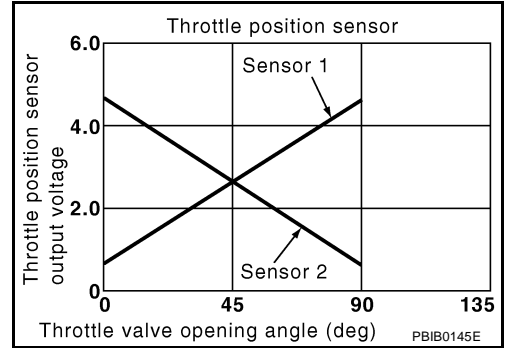

CONSULT-II Reference Value in Data Monitor Mode

ABS00C4

Specification data are reference values.

MONITOR ITEM	CONDITION		SPECIFICATION
THRTL SEN1 THRTL SEN2*	<ul style="list-style-type: none"> Ignition switch: ON (Engine stopped) Shift lever: D 	Accelerator pedal: Fully released	More than 0.36V
		Accelerator pedal: Fully depressed	Less than 4.75V

*: Throttle position sensor 2 signal is converted by ECM internally. Thus, it differs from ECM terminal voltage signal.

On Board Diagnosis Logic

ABS00C5

This self-diagnosis has the one trip detection logic.

DTC No.	Trouble diagnosis name	DTC detecting condition	Possible cause
P2135 2135	Throttle position sensor circuit range/performance problem	Rationally incorrect voltage is sent to ECM compared with the signals from TP sensor 1 and TP sensor 2.	<ul style="list-style-type: none"> Harness or connector (The TP sensor 1 and 2 circuit is open or shorted.) (APP sensor 2 circuit is shorted). Electric throttle control actuator (TP sensor 1 and 2) Accelerator pedal position sensor.

FAIL-SAFE MODE

When the malfunction is detected, the ECM enters fail-safe mode and the MIL lights up.

Engine operation condition in fail-safe mode

The ECM controls the electric throttle control actuator in regulating the throttle opening in order for the idle position to be within +10 degrees.
 The ECM regulates the opening speed of the throttle valve to be slower than the normal condition.
 So, the acceleration will be poor.

DTC Confirmation Procedure**NOTE:**

If DTC Confirmation Procedure has been previously conducted, always turn ignition switch OFF and wait at least 10 seconds before conducting the next test.

TESTING CONDITION:

Before performing the following procedure, confirm that battery voltage is more than 10V at idle.

 **WITH CONSULT-II**

1. Turn ignition switch ON.
2. Select "DATA MONITOR" mode with CONSULT-II.
3. Start engine and let it idle for 1 second.
4. If DTC is detected, go to [EC-572, "Diagnostic Procedure"](#) .

DATA MONITOR	
MONITOR	NO DTC
ENG SPEED	XXX rpm

SEF058Y

 **WITH GST**

Follow the procedure "WITH CONSULT-II" above.

DTC P2135 TP SENSOR

[VQ35DE]

Wiring Diagram

ABS00C17

EC-TPS3-01

— : DETECTABLE LINE FOR DTC
 - - - : NON-DETECTABLE LINE FOR DTC

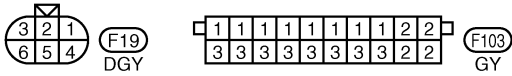
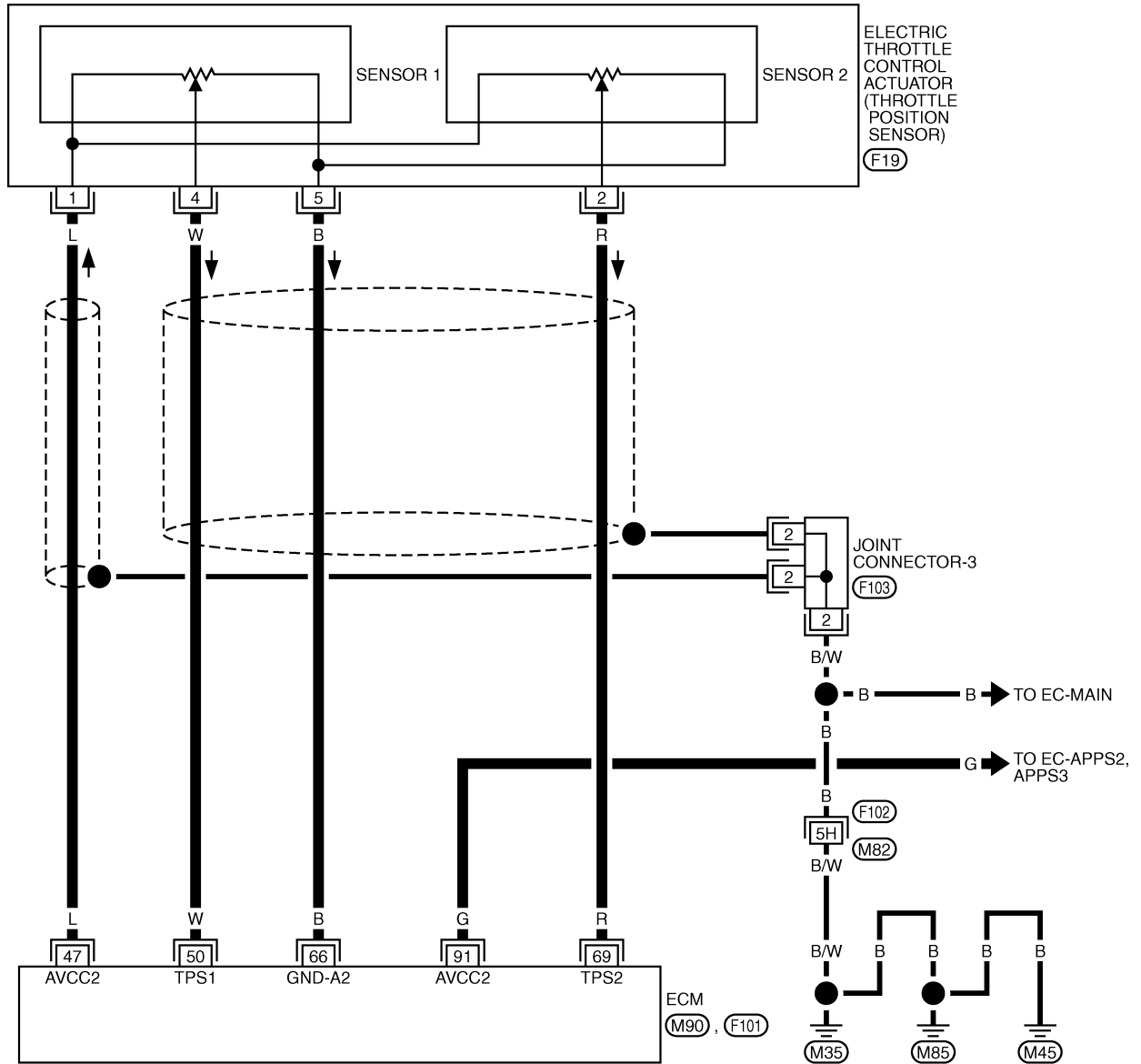

REFER TO THE FOLLOWING.
 F102 -SUPER MULTIPLE JUNCTION (SMJ)

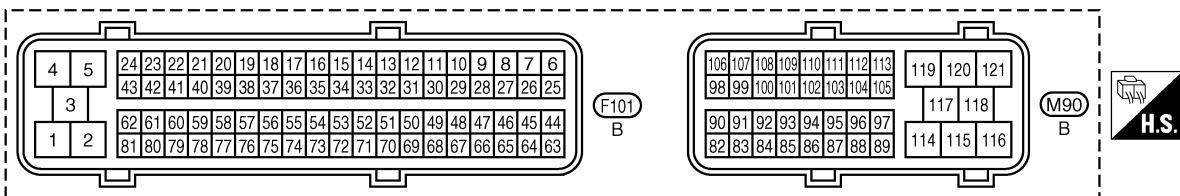

TBWM0427E

DTC P2135 TP SENSOR

[VQ35DE]

Specification data are reference values and are measured between each terminal and ground.

CAUTION:

Do not use ECM ground terminals when measuring input/output voltage. Doing so may result in damage to the ECM's transistor. Use a ground other than ECM terminals, such as the ground.

TER-MINAL NO.	WIRE COLOR	ITEM	CONDITION	DATA (DC Voltage)
47	L	Sensor power supply (Throttle position sensor)	[Ignition switch: ON]	Approximately 5V
50	W	Throttle position sensor 1	[Ignition switch: ON] ● Engine stopped ● Shift lever: D ● Accelerator pedal: Fully released	More than 0.36V
			[Ignition switch: ON] ● Engine stopped ● Shift lever: D ● Accelerator pedal: Fully depressed	Less than 4.75V
66	B	Sensor ground (Throttle position sensor)	[Engine is running] ● Warm-up condition ● Idle speed	Approximately 0V
69	R	Throttle position sensor 2	[Ignition switch: ON] ● Engine stopped ● Shift lever: D ● Accelerator pedal: Fully released	Less than 4.75V
			[Ignition switch: ON] ● Engine stopped ● Shift lever: D ● Accelerator pedal: Fully depressed	More than 0.36V
91	G	Sensor power supply (APP sensor 2)	[Ignition switch: ON]	Approximately 5V

Diagnostic Procedure

ABS00C18

1. CHECK GROUND CONNECTIONS

1. Turn ignition switch OFF.
2. Loosen and retighten ground three screws on the body. Refer to [EC-141, "Ground Inspection"](#).

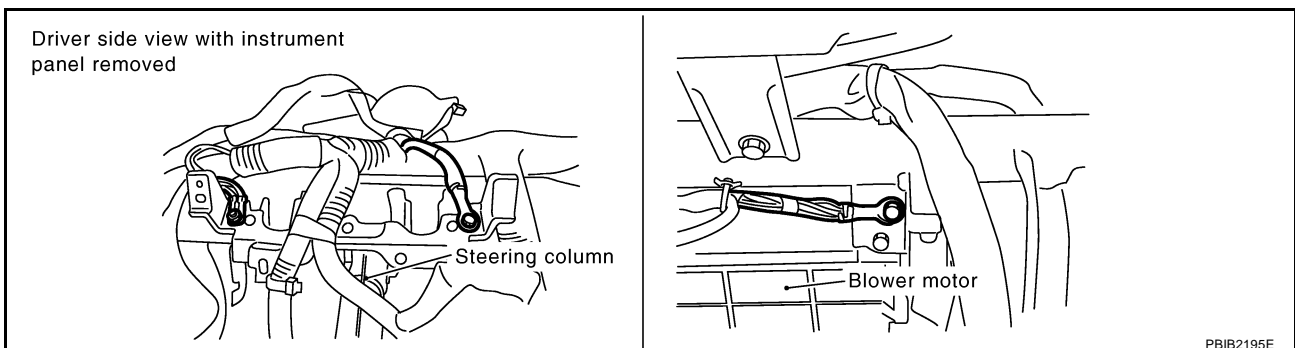

PBIB2195E

OK or NG

- OK >> GO TO 2.
- NG >> Repair or replace ground connections.

2. CHECK THROTTLE POSITION SENSOR POWER SUPPLY CIRCUIT-1

1. Disconnect electric throttle control actuator harness connector.
2. Turn ignition switch ON.

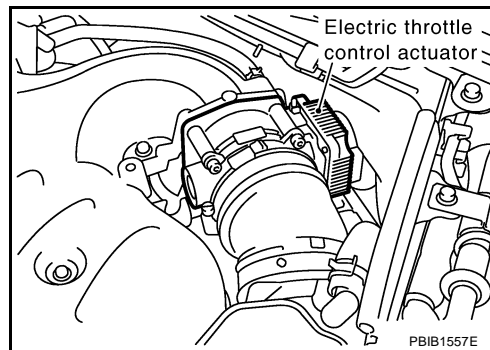

3. Check voltage between electric throttle control actuator terminal 1 and ground with CONSULT-II or tester.

Voltage: Approximately 5V

OK or NG

- OK >> GO TO 7.
- NG >> GO TO 3.

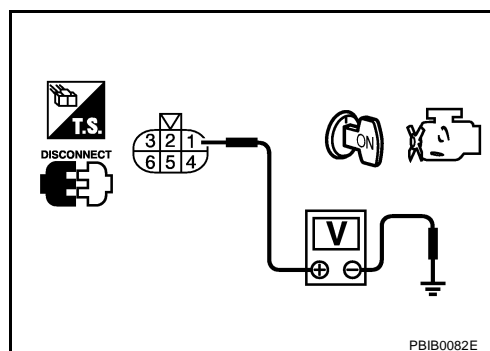

3. CHECK THROTTLE POSITION SENSOR POWER SUPPLY CIRCUIT-II

1. Turn ignition switch OFF.
2. Disconnect ECM harness connector.
3. Check harness continuity between electric throttle control actuator terminal 1 and ECM terminal 47. Refer to Wiring Diagram.

Continuity should exist.

OK or NG

- OK >> GO TO 4.
- NG >> Repair or replace open circuit.

4. CHECK THROTTLE POSITION SENSOR POWER SUPPLY CIRCUIT-III

Check the following.

- Harness for short to power and short to ground, between the following terminals.

ECM terminal	Sensor terminal	Reference Wiring Diagram
47	Electric throttle control actuator terminal 1	EC-192
91	APP sensor terminal 4	EC-564

OK or NG

- OK >> GO TO 5.
- NG >> Repair short to ground or short to power in harness or connectors.

5. CHECK APP SENSOR

Refer to [EC-568, "Component Inspection"](#) .

OK or NG

- OK >> GO TO 11.
- NG >> GO TO 6.

6. REPLACE ACCELERATOR PEDAL ASSEMBLY

1. Replace accelerator pedal assembly.
2. Perform [EC-49, "Accelerator Pedal Released Position Learning"](#) .
3. Perform [EC-49, "Throttle Valve Closed Position Learning"](#) .
4. Perform [EC-49, "Idle Air Volume Learning"](#) .

>> INSPECTION END

7. CHECK THROTTLE POSITION SENSOR GROUND CIRCUIT FOR OPEN AND SHORT

1. Turn ignition switch OFF.
2. Disconnect ECM harness connector.
3. Check harness continuity between electric throttle control actuator terminal 5 and ECM terminal 66.
Refer to Wiring Diagram.

Continuity should exist.

4. Also check harness for short to ground and short to power.

OK or NG

OK >> GO TO 8.

NG >> Repair open circuit or short to ground or short to power in harness or connectors.

8. CHECK THROTTLE POSITION SENSOR INPUT SIGNAL CIRCUIT FOR OPEN AND SHORT

1. Check harness continuity between ECM terminal 50 and electric throttle control actuator terminal 4, ECM terminal 69 and electric throttle control actuator terminal 2.
Refer to Wiring Diagram.

Continuity should exist.

2. Also check harness for short to ground and short to power.

OK or NG

OK >> GO TO 9.

NG >> Repair open circuit or short to ground or short to power in harness or connectors.

9. CHECK THROTTLE POSITION SENSOR

Refer to [EC-575, "Component Inspection"](#) .

OK or NG

OK >> GO TO 11.

NG >> GO TO 10.

10. REPLACE ELECTRIC THROTTLE CONTROL ACTUATOR

1. Replace the electric throttle control actuator.
2. Perform [EC-49, "Throttle Valve Closed Position Learning"](#) .
3. Perform [EC-49, "Idle Air Volume Learning"](#) .

>> INSPECTION END

11. CHECK INTERMITTENT INCIDENT

Refer to [EC-135, "TROUBLE DIAGNOSIS FOR INTERMITTENT INCIDENT"](#) .

>> INSPECTION END

Component Inspection THROTTLE POSITION SENSOR

1. Reconnect all harness connectors disconnected.
2. Perform [EC-49, "Throttle Valve Closed Position Learning"](#) .
3. Turn ignition switch ON.
4. Set selector lever to D.
5. Check voltage between ECM terminals 50 (TP sensor 1signal), 69 (TP sensor 2signal) and ground under the following conditions.

Terminal	Accelerator pedal	Voltage
50 (Throttle position sensor 1)	Fully released	More than 0.36V
	Fully depressed	Less than 4.75V
69 (Throttle position sensor 2)	Fully released	Less than 4.75V
	Fully depressed	More than 0.36V

6. If NG, replace electric throttle control actuator and go to the next step.
7. Perform [EC-49, "Throttle Valve Closed Position Learning"](#) .
8. Perform [EC-49, "Idle Air Volume Learning"](#) .

Removal and Installation ELECTRIC THROTTLE CONTROL ACTUATOR

Refer to [EM-19, "INTAKE MANIFOLD COLLECTOR"](#) .

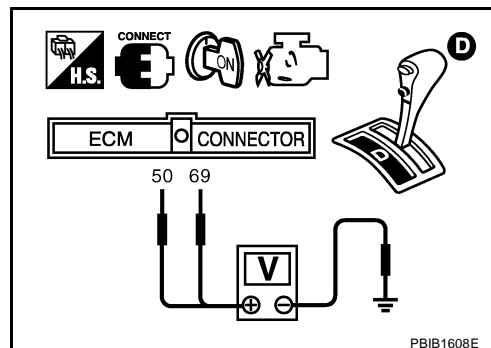

PBIB1608E

DTC P2138 APP SENSOR

PF18002

Component Description

ABS00C1B

The accelerator pedal position sensor is installed on the upper end of the accelerator pedal assembly. The sensor detects the accelerator position and sends a signal to the ECM.

Accelerator pedal position sensor has two sensors. These sensors are a kind of potentiometers which transform the accelerator pedal position into output voltage, and emit the voltage signal to the ECM. In addition, these sensors detect the opening and closing speed of the accelerator pedal and feed the voltage signals to the ECM. The ECM judges the current opening angle of the accelerator pedal from these signals and controls the throttle control motor based on these signals.

Idle position of the accelerator pedal is determined by the ECM receiving the signal from the accelerator pedal position sensor. The ECM uses this signal for the engine operation such as fuel cut.

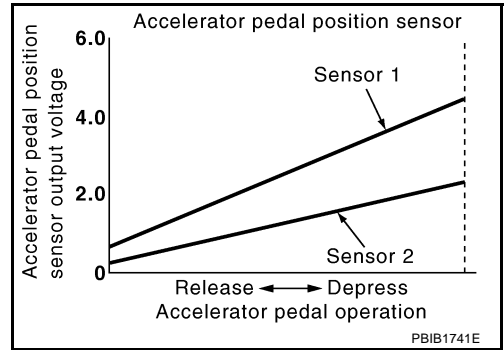

CONSULT-II Reference Value in Data Monitor Mode

ABS00C1C

Specification data are reference values.

MONITOR ITEM	CONDITION		SPECIFICATION
ACCEL SEN1	● Ignition switch: ON (Engine stopped)	Accelerator pedal: Fully released	0.5 - 1.0V
		Accelerator pedal: Fully depressed	4.0 - 4.8V
ACCEL SEN2*	● Ignition switch: ON (Engine stopped)	Accelerator pedal: Fully released	0.3 - 1.2V
		Accelerator pedal: Fully depressed	3.9 - 4.8V
CLSD THL POS	● Ignition switch: ON (Engine stopped)	Accelerator pedal: Fully released	ON
		Accelerator pedal: Slightly depressed	OFF

*: Accelerator pedal position sensor 2 signal is converted by ECM internally. Thus, it differs from ECM terminal voltage.

On Board Diagnosis Logic

ABS00C1D

This self-diagnosis has the one trip detection logic.

NOTE:

If DTC P2138 is displayed with DTC P1229, first perform the trouble diagnosis for DTC P1229. Refer to [EC-489, "DTC P1229 SENSOR POWER SUPPLY"](#).

DTC No.	Trouble diagnosis name	DTC detecting condition	Possible cause
P2138 2138	Accelerator pedal position sensor circuit range/performance problem	Rationally incorrect voltage is sent to ECM compared with the signals from APP sensor 1 and APP sensor 2.	<ul style="list-style-type: none"> ● Harness or connector (The APP sensor 1 and 2 circuit is open or shorted.) (TP sensor circuit is shorted.) ● Accelerator pedal position sensor 1 and 2 ● Electric throttle control actuator (TP sensor 1 and 2)

FAIL-SAFE MODE

When the malfunction is detected, ECM enters fail-safe mode and the MIL lights up.

Engine operating condition in fail-safe mode

The ECM controls the electric throttle control actuator in regulating the throttle opening in order for the idle position to be within +10 degrees.

The ECM regulates the opening speed of the throttle valve to be slower than the normal condition.

So, the acceleration will be poor.

DTC Confirmation Procedure**NOTE:**

If DTC Confirmation Procedure has been previously conducted, always turn ignition switch OFF and wait at least 10 seconds before conducting the next test.

TESTING CONDITION:

Before performing the following procedure, confirm that battery voltage is more than 10V at idle.

WITH CONSULT-II

1. Turn ignition switch ON.
2. Select "DATA MONITOR" mode with CONSULT-II.
3. Start engine and let it idle for 1 second.
4. If DTC is detected, go to [EC-579, "Diagnostic Procedure"](#) .

DATA MONITOR	
MONITOR	NO DTC
ENG SPEED	XXX rpm

SEF058Y

WITH GST

Follow the procedure "WITH CONSULT-II" above.

A

EC

C

D

E

F

G

H

I

J

K

L

M

DTC P2138 APP SENSOR

[VQ35DE]

Wiring Diagram

ABS00CIF

EC-APPS3-01

: DETECTABLE LINE FOR DTC
 : NON-DETECTABLE LINE FOR DTC

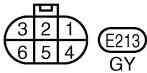
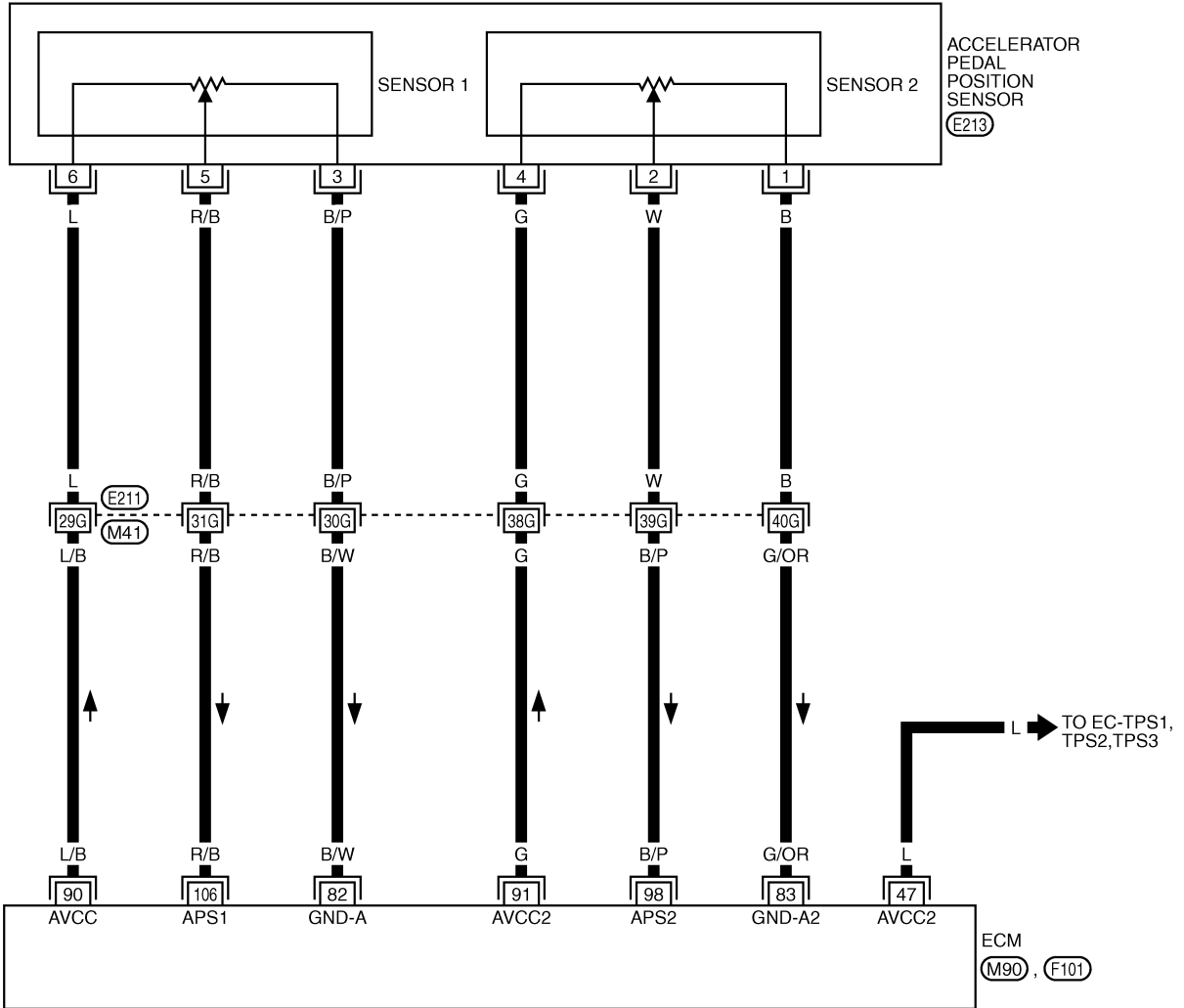

REFER TO THE FOLLOWING.
 (E211) -SUPER MULTIPLE JUNCTION (SMJ)

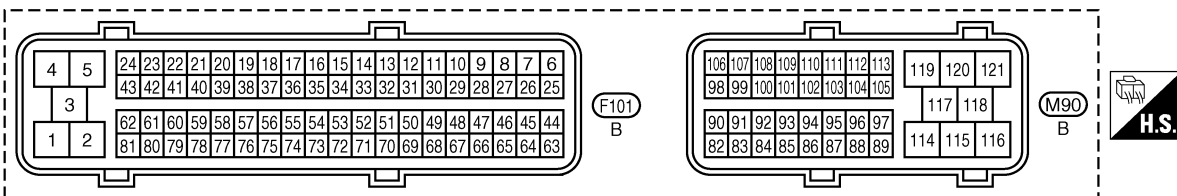

TBWM0507E

DTC P2138 APP SENSOR

[VQ35DE]

Specification data are reference values and are measured between each terminal and ground.

CAUTION:

Do not use ECM ground terminals when measuring input/output voltage. Doing so may result in damage to the ECM's transistor. Use a ground other than ECM terminals, such as the ground.

TER-MINAL NO.	WIRE COLOR	ITEM	CONDITION	DATA (DC Voltage)
47	L	Sensor power supply (Throttle position sensor)	[Ignition switch: ON]	Approximately 5V
82	B/W	Sensor ground (APP sensor 1)	[Engine is running] ● Warm-up condition ● Idle speed	Approximately 0V
83	G/OR	Sensor ground (APP sensor 2)	[Engine is running] ● Warm-up condition ● Idle speed	Approximately 0V
90	L/B	Sensor power supply (APP sensor 1)	[Ignition switch: ON]	Approximately 5V
91	G	Sensor power supply (APP sensor 2)	[Ignition switch: ON]	Approximately 5V
98	B/P	Accelerator pedal position sensor 2	[Ignition switch: ON] ● Engine stopped ● Accelerator pedal: Fully released	0.15 - 0.60V
			[Ignition switch: ON] ● Engine stopped ● Accelerator pedal: Fully depressed	1.95 - 2.40V
106	R/B	Accelerator pedal position sensor 1	[Ignition switch: ON] ● Engine stopped ● Accelerator pedal: Fully released	0.5 - 1.0V
			[Ignition switch: ON] ● Engine stopped ● Accelerator pedal: Fully depressed	3.9 - 4.7V

Diagnostic Procedure

ABS00CIG

1. CHECK GROUND CONNECTIONS

1. Turn ignition switch OFF.
2. Loosen and retighten ground three screws on the body. Refer to [EC-141, "Ground Inspection"](#).

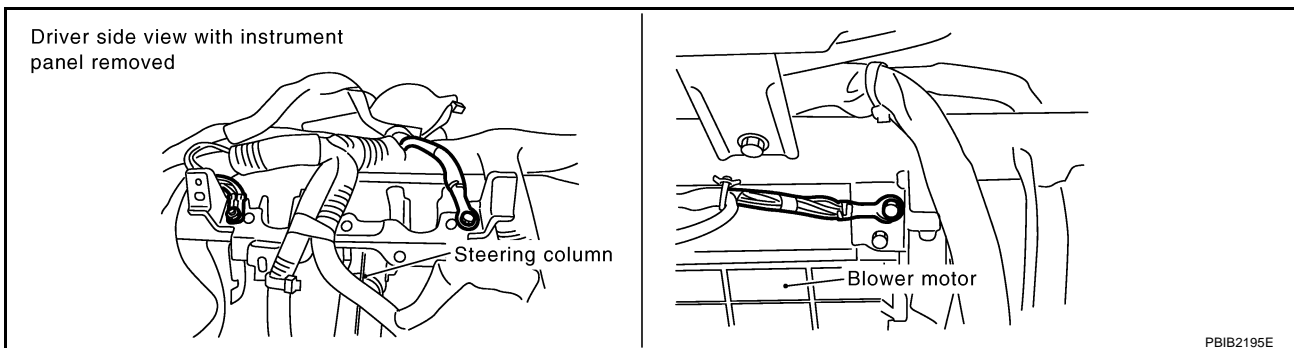

PBIB2195E

OK or NG

- OK >> GO TO 2.
- NG >> Repair or replace ground connections.

2. CHECK APP SENSOR 1 POWER SUPPLY CIRCUIT

1. Disconnect accelerator pedal position (APP) sensor harness connector.
2. Turn ignition switch ON.

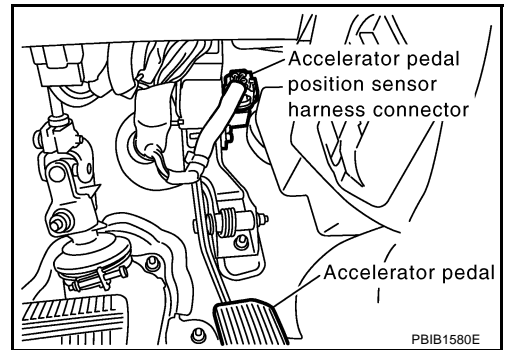

3. Check voltage between APP sensor terminals 6 and ground with CONSULT-II or tester.

Voltage: Approximately 5V

OK or NG

- OK >> GO TO 4.
 NG >> GO TO 3.

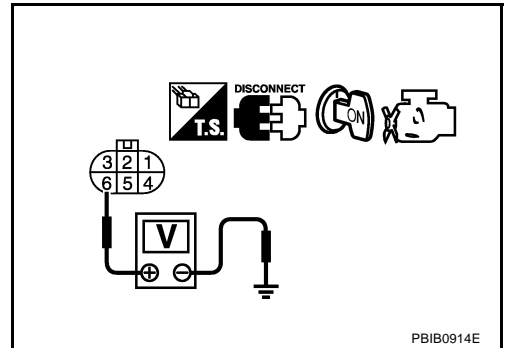

3. DETECT MALFUNCTIONING PART

Check the following.

- Harness connectors E211, M41
- Harness for open or short between ECM and accelerator pedal position sensor

>> Repair open circuit or short to ground or short to power in harness or connectors.

4. CHECK APP SENSOR 2 POWER SUPPLY CIRCUIT-I

Check voltage between APP sensor terminal 4 and ground with CONSULT-II or tester.

Voltage: Approximately 5V

OK or NG

- OK >> GO TO 11.
 NG >> GO TO 5.

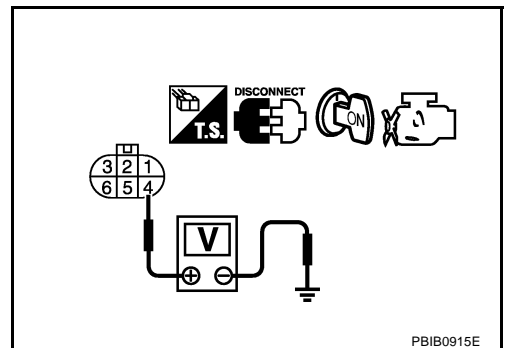

5. CHECK APP SENSOR 2 POWER SUPPLY CIRCUIT-II

1. Turn ignition switch OFF.
2. Disconnect ECM harness connector.
3. Check harness continuity between APP sensor terminal 4 and ECM terminal 91.
Refer to wiring diagram.

Continuity should exist.

OK or NG

- OK >> GO TO 7.
- NG >> GO TO 6.

6. DETECT MALFUNCTIONING PART

Check the following.

- Harness connectors E211, M41
- Harness for open or short between ECM and accelerator pedal position sensor

>> Repair open circuit or short to ground or short to power in harness or connectors.

7. CHECK APP SENSOR 2 POWER SUPPLY CIRCUIT-III

Check the following.

- Harness for short to power and short to ground, between the following terminals.

ECM terminal	Sensor terminal	Reference Wiring Diagram
91	APP sensor terminal 4	EC-578
47	Electric throttle control actuator terminal 1	EC-192

OK or NG

- OK >> GO TO 9.
- NG >> GO TO 8.

8. DETECT MALFUNCTIONING PART

Check the following.

- Harness connectors E211, M41
- Harness for open or short between ECM and accelerator pedal position sensor

>> Repair open circuit or short to ground or short to power in harness or connectors.

9. CHECK THROTTLE POSITION SENSOR

Refer to [EC-575, "Component Inspection"](#) .

OK or NG

- OK >> GO TO 17.
- NG >> GO TO 10.

10. REPLACE ELECTRIC THROTTLE CONTROL ACTUATOR

1. Replace electric throttle control actuator.
2. Perform [EC-49, "Throttle Valve Closed Position Learning"](#) .
3. Perform [EC-49, "Idle Air Volume Learning"](#) .

>> **INSPECTION END**

11. CHECK APP SENSOR GROUND CIRCUIT FOR OPEN AND SHORT

1. Turn ignition switch OFF.
2. Disconnect ECM harness connector.
3. Check harness continuity between APP sensor terminals 3 and ECM terminal 82 (sensor 1), APP sensor terminal 1 and ECM terminal 83 (sensor 2).
Refer to Wiring Diagram.

Continuity should exist.

4. Also check harness for short to ground and short to power.

OK or NG

- OK >> GO TO 13.
NG >> GO TO 12.

12. DETECT MALFUNCTIONING PART

Check the following.

- Harness connectors E211, M41
- Harness for open or short between ECM and accelerator pedal position sensor

>> Repair open circuit or short to ground or short to power in harness or connectors.

13. CHECK APP SENSOR INPUT SIGNAL CIRCUIT FOR OPEN AND SHORT

1. Check harness continuity between ECM terminal 106 and APP sensor terminal 5, ECM terminal 98 and APP sensor terminal 2.
Refer to Wiring Diagram.

Continuity should exist.

2. Also check harness for short to ground and short to power.

OK or NG

- OK >> GO TO 15.
NG >> GO TO 14.

14. DETECT MALFUNCTIONING PART

Check the following.

- Harness connectors E211, M41
- Harness for open or short between ECM and accelerator pedal position sensor

>> Repair open circuit or short to ground or short to power in harness or connectors.

15. CHECK APP SENSOR

Refer to [EC-584, "Component Inspection"](#) .

OK or NG

- OK >> GO TO 17.
NG >> GO TO 16.

16. REPLACE ACCELERATOR PEDAL ASSEMBLY

1. Replace accelerator pedal assembly.
2. Perform [EC-49, "Accelerator Pedal Released Position Learning"](#) .
3. Perform [EC-49, "Throttle Valve Closed Position Learning"](#) .
4. Perform [EC-49, "Idle Air Volume Learning"](#) .

>> INSPECTION END

17. CHECK INTERMITTENT INCIDENT

Refer to [EC-135, "TROUBLE DIAGNOSIS FOR INTERMITTENT INCIDENT"](#) .

>> INSPECTION END

A
EC
C
D
E
F
G
H
I
J
K
L
M

Component Inspection
ACCELERATOR PEDAL POSITION SENSOR

1. Reconnect all harness connectors disconnected.
2. Turn ignition switch ON.
3. Check voltage between ECM terminals 106 (APP sensor 1 signal), 98 (APP sensor 2 signal) and ground under the following conditions.

Terminal	Accelerator pedal	Voltage
106 (Accelerator pedal position sensor 1)	Fully released	0.5 - 1.0V
	Fully depressed	3.9 - 4.7V
98 (Accelerator pedal position sensor 2)	Fully released	0.15 - 0.60V
	Fully depressed	1.95 - 2.40V

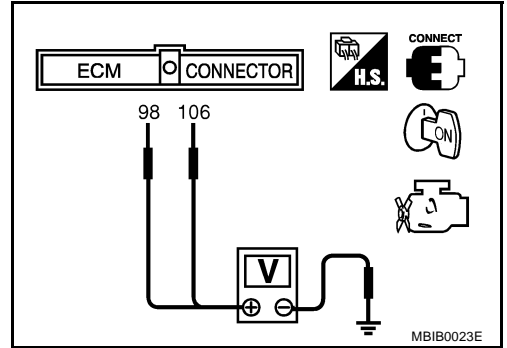

4. If NG, replace accelerator pedal assembly and go to next step.
5. Perform [EC-49, "Accelerator Pedal Released Position Learning"](#) .
6. Perform [EC-49, "Throttle Valve Closed Position Learning"](#) .
7. Perform [EC-49, "Idle Air Volume Learning"](#) .

Removal and Installation
ACCELERATOR PEDAL

Refer to [ACC-3, "ACCELERATOR CONTROL SYSTEM"](#) .

IGNITION SIGNAL

PPF:22448

Component Description

ABS006Y4

IGNITION COIL & POWER TRANSISTOR

The ignition signal from the ECM is sent to and amplified by the power transistor. The power transistor turns ON and OFF the ignition coil primary circuit. This ON/OFF operation induces the proper high voltage in the coil secondary circuit.

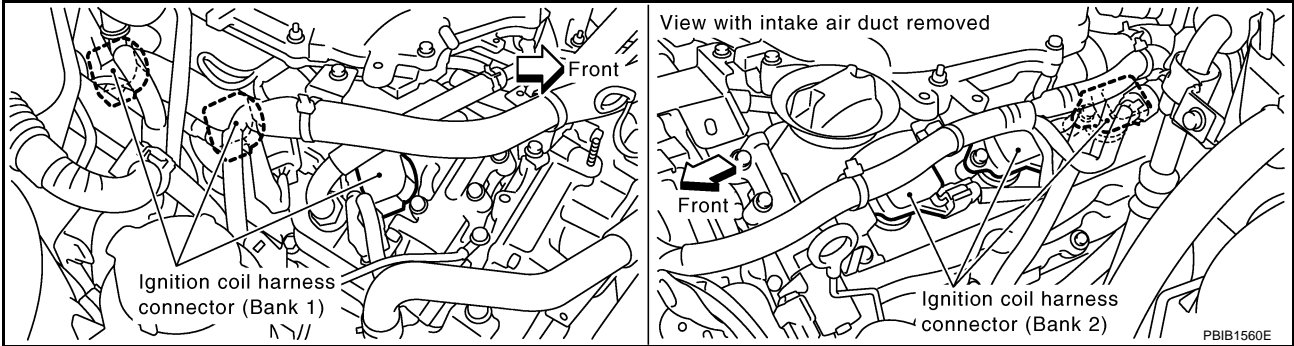

A
EC
C
D
E
F
G
H
I
J
K
L
M

IGNITION SIGNAL

[VQ35DE]

ABS006Y5

Wiring Diagram

EC-IGNSYS-01

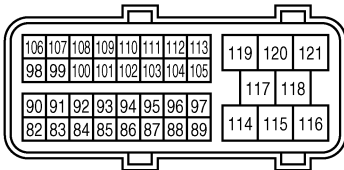
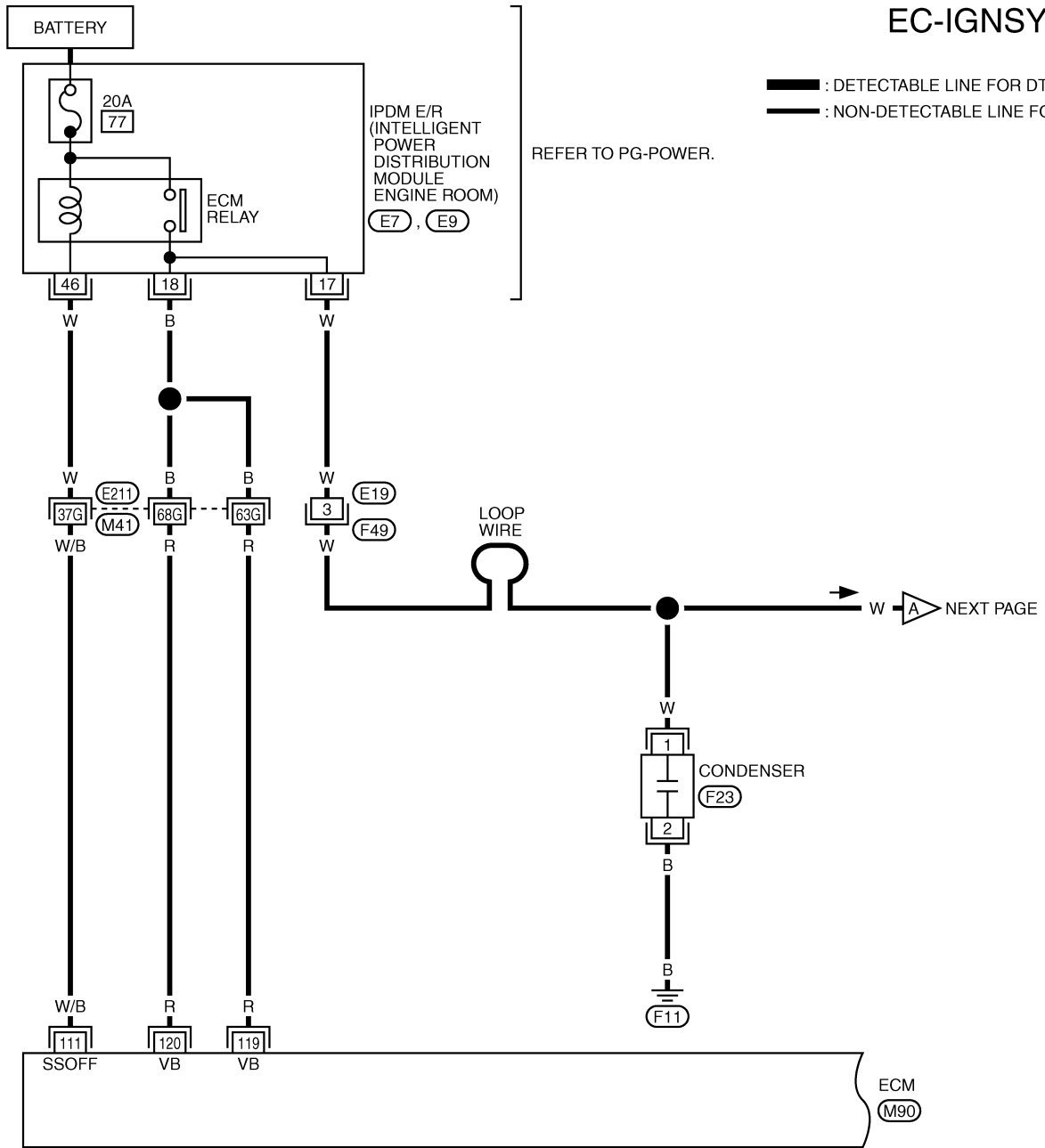

REFER TO THE FOLLOWING.

(E21) -SUPER MULTIPLE JUNCTION (SMJ)

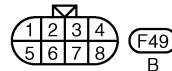
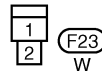
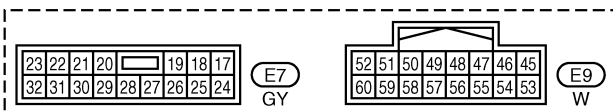

TBWM0261E

IGNITION SIGNAL

[VQ35DE]

Specification data are reference values and are measured between each terminal and ground.

CAUTION:

Do not use ECM ground terminals when measuring input/output voltage. Doing so may result in damage to the ECM's transistor. Use a ground other than ECM terminals, such as the ground.

TER-MINAL NO.	WIRE COLOR	ITEM	CONDITION	DATA (DC Voltage)
111	W/B	ECM relay (Self shut-off)	[Engine is running] [Ignition switch: OFF] <ul style="list-style-type: none"> For a few seconds after turning ignition switch OFF 	0 - 1.5V
			[Ignition switch: OFF] <ul style="list-style-type: none"> More than a few seconds passed after turning ignition switch OFF 	BATTERY VOLTAGE (11 - 14V)
119 120	R R	Power supply for ECM	[Ignition switch: ON]	BATTERY VOLTAGE (11 - 14V)

A
EC
C
D
E
F
G
H
I
J
K
L
M

IGNITION SIGNAL

[VQ35DE]

EC-IGNSYS-02

— : DETECTABLE LINE FOR DTC
 - - - : NON-DETECTABLE LINE FOR DTC

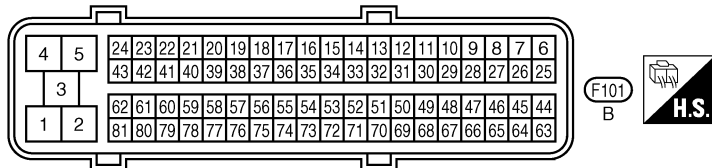
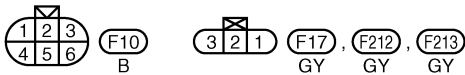
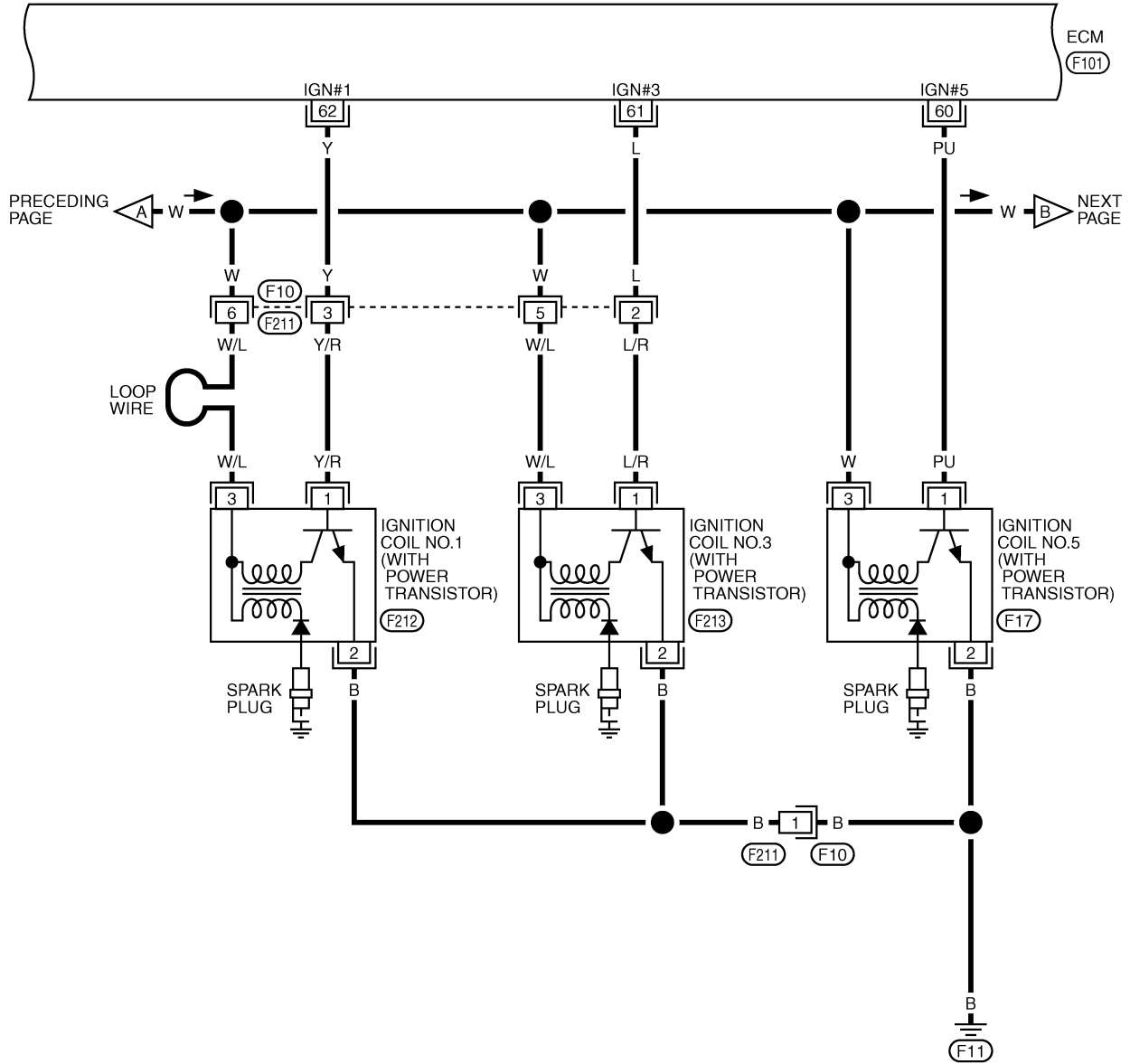

TBWM0308E

IGNITION SIGNAL

[VQ35DE]

Specification data are reference values and are measured between each terminal and ground.
Pulse signal is measured by CONSULT-II.

CAUTION:

Do not use ECM ground terminals when measuring input/output voltage. Doing so may result in damage to the ECM's transistor. Use a ground other than ECM terminals, such as the ground.

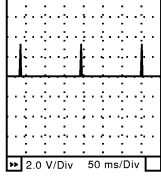
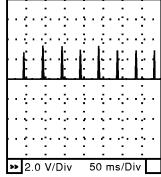
TER-MINAL NO.	WIRE COLOR	ITEM	CONDITION	DATA (DC Voltage)
60 61 62	PU L Y	Ignition signal No. 5 Ignition signal No. 3 Ignition signal No. 1	<p>[Engine is running]</p> <ul style="list-style-type: none"> ● Warm-up condition ● Idle speed <p>NOTE: The pulse cycle changes depending on rpm at idle</p>	<p>0 - 0.2V★</p>  <p>SEC986C</p>
			<p>[Engine is running]</p> <ul style="list-style-type: none"> ● Warm-up condition ● Engine speed is 2,500 rpm 	<p>0.1 - 0.4V★</p>  <p>SEC987C</p>

★: Average voltage for pulse signal (Actual pulse signal can be confirmed by oscilloscope.)

A
EC
C
D
E
F
G
H
I
J
K
L
M

IGNITION SIGNAL

[VQ35DE]

EC-IGNSYS-03

— : DETECTABLE LINE FOR DTC
 - - - : NON-DETECTABLE LINE FOR DTC

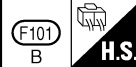
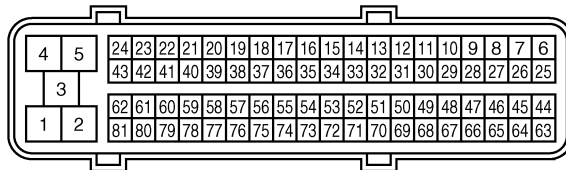
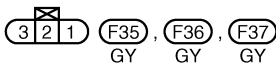
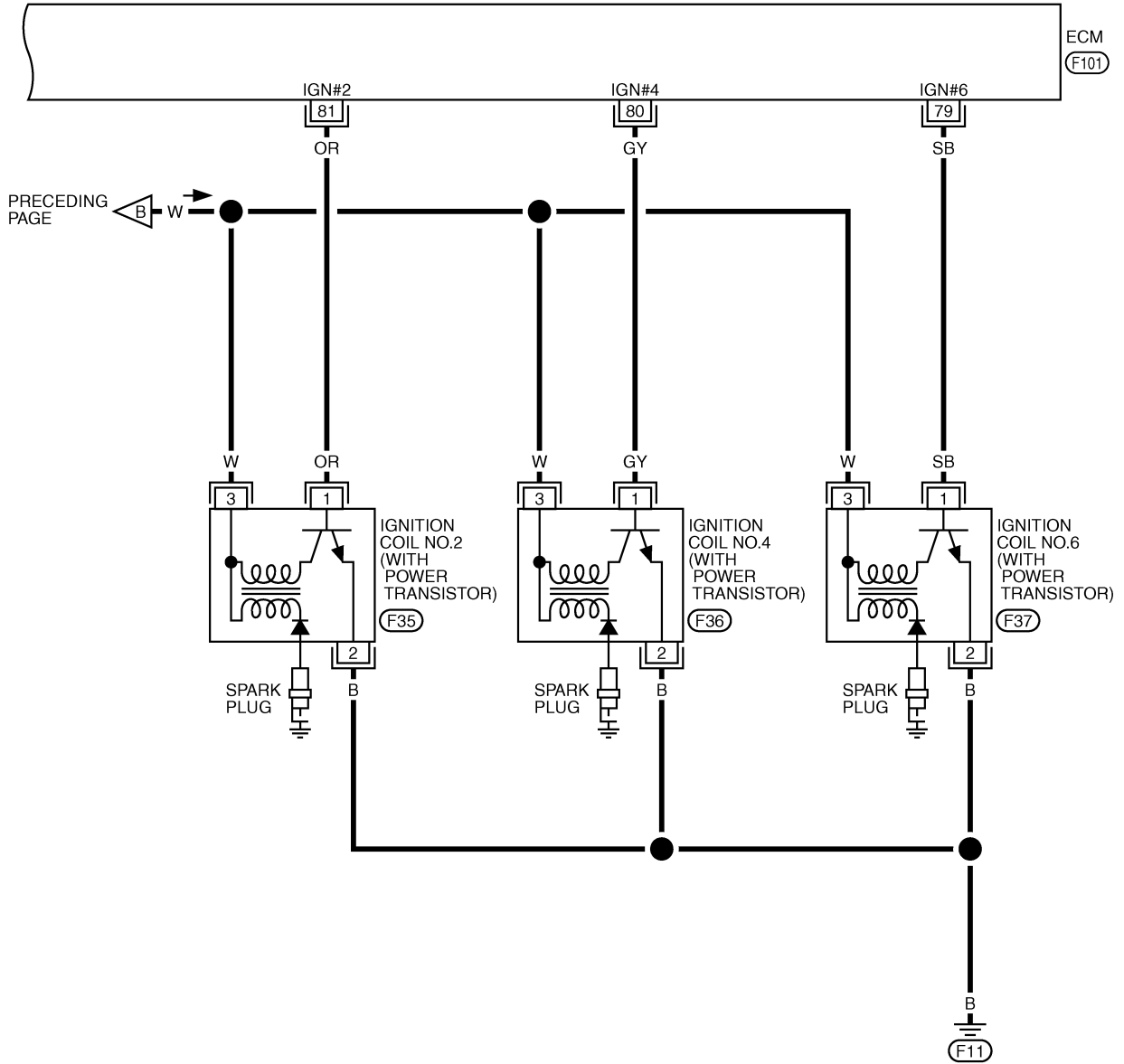

TBWM0309E

IGNITION SIGNAL

[VQ35DE]

Specification data are reference values and are measured between each terminal and ground.
Pulse signal is measured by CONSULT-II.

CAUTION:

Do not use ECM ground terminals when measuring input/output voltage. Doing so may result in damage to the ECM's transistor. Use a ground other than ECM terminals, such as the ground.

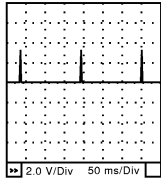
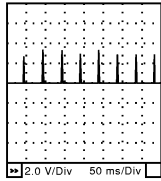
TER-MINAL NO.	WIRE COLOR	ITEM	CONDITION	DATA (DC Voltage)
79 80 81	SB GY OR	Ignition signal No. 6 Ignition signal No. 4 Ignition signal No. 2	<p>[Engine is running]</p> <ul style="list-style-type: none"> ● Warm-up condition ● Idle speed <p>NOTE: The pulse cycle changes depending on rpm at idle</p>	<p>0 - 0.2V★</p>  <p>SEC986C</p>
			<p>[Engine is running]</p> <ul style="list-style-type: none"> ● Warm-up condition ● Engine speed is 2,500 rpm 	<p>0.1 - 0.4V★</p>  <p>SEC987C</p>

★: Average voltage for pulse signal (Actual pulse signal can be confirmed by oscilloscope.)

Diagnostic Procedure

ABS00D10

1. CHECK ENGINE START

Turn ignition switch OFF, and restart engine.

Is engine running?

Yes or No

Yes (With CONSULT-II)>>GO TO 2.

Yes (Without CONSULT-II)>>GO TO 3.

No >> GO TO 4.

2. CHECK OVERALL FUNCTION

④ **With CONSULT-II**

1. Perform "POWER BALANCE" in "ACTIVE TEST" mode with CONSULT-II.

2. Make sure that each circuit produces a momentary engine speed drop.

OK or NG

OK >> **INSPECTION END**

NG >> GO TO 10.

ACTIVE TEST	
POWER BALANCE	
MONITOR	
ENG SPEED	XXX rpm
MAS A/F SE-B1	XXX V

PBIB0133E

3. CHECK OVERALL FUNCTION

⊗ **Without CONSULT-II**

1. Let engine idle.
2. Read the voltage signal between ECM terminals 60, 61, 62, 79, 80, 81 and ground with an oscilloscope.
3. Verify that the oscilloscope screen shows the signal wave as shown below.

NOTE:

The pulse cycle changes depending on rpm at idle.

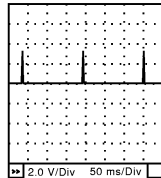

SEC986C

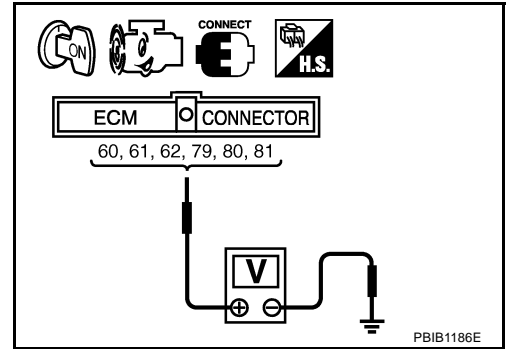

OK or NG

- OK >> **INSPECTION END**
 NG >> GO TO 10.

4. CHECK IGNITION COIL POWER SUPPLY CIRCUIT-I

1. Turn ignition switch OFF, wait at least 10 seconds and then turn ON.
2. Check voltage between ECM terminals 119, 120 and ground with CONSULT-II or tester.

Voltage: Battery voltage

OK or NG

- OK >> GO TO 5.
 NG >> Go to [EC-136. "POWER SUPPLY AND GROUND CIRCUIT"](#).

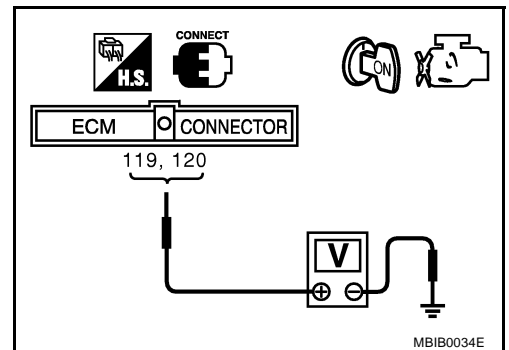

5. CHECK IGNITION COIL POWER SUPPLY CIRCUIT-II

1. Turn ignition switch OFF.
2. Disconnect condenser harness connector.
3. Turn ignition switch ON.

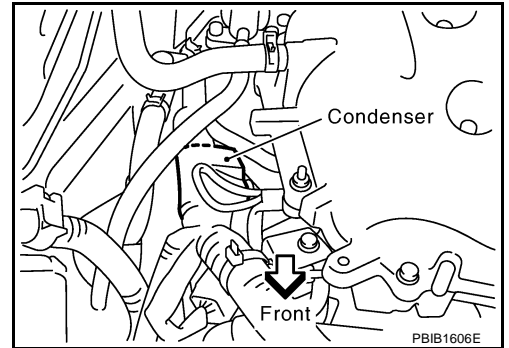

4. Check voltage between condenser terminal 1 and ground with CONSULT-II or tester.

Voltage: Battery voltage

OK or NG

- OK >> GO TO 7.
 NG >> GO TO 6.

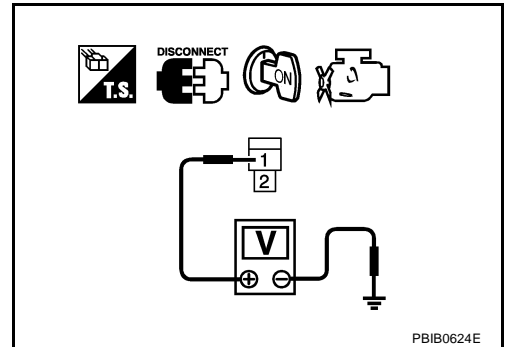

6. CHECK IGNITION COIL POWER SUPPLY CIRCUIT-III

1. Turn ignition switch OFF.
2. Disconnect IPDM E/R harness connector.
3. Check harness continuity between IPDM E/R terminal 17 and condenser terminal 1. Refer to Wiring Diagram.

Continuity should exist.

4. Also check harness for short to ground and short to power.

OK or NG

- OK >> Go to [EC-136, "POWER SUPPLY AND GROUND CIRCUIT"](#) .
 NG >> GO TO 7.

7. DETECT MALFUNCTIONING PART

Check the following.

- Harness connectors E19, F49
- Harness for open or short between condenser and IPDM E/R

>> Repair open circuit or short to ground or short to power in harness or connectors.

8. CHECK CONDENSER GROUND CIRCUIT FOR OPEN AND SHORT

1. Turn ignition switch OFF.
2. Check harness continuity between condenser terminal 2 and ground.
Refer to Wiring Diagram.

Continuity should exist.

3. Also check harness for short to power.

OK or NG

OK >> GO TO 9.

NG >> Repair open circuit or short to power in harness or connectors.

9. CHECK CONDENSER

Refer to [EC-595, "Component Inspection"](#) .

OK or NG

OK >> GO TO 10.

NG >> Replace condenser.

10. CHECK IGNITION COIL POWER SUPPLY CIRCUIT-V

1. Turn ignition switch OFF.
2. Reconnect all harness connectors disconnected.
3. Disconnect ignition coil harness connector.

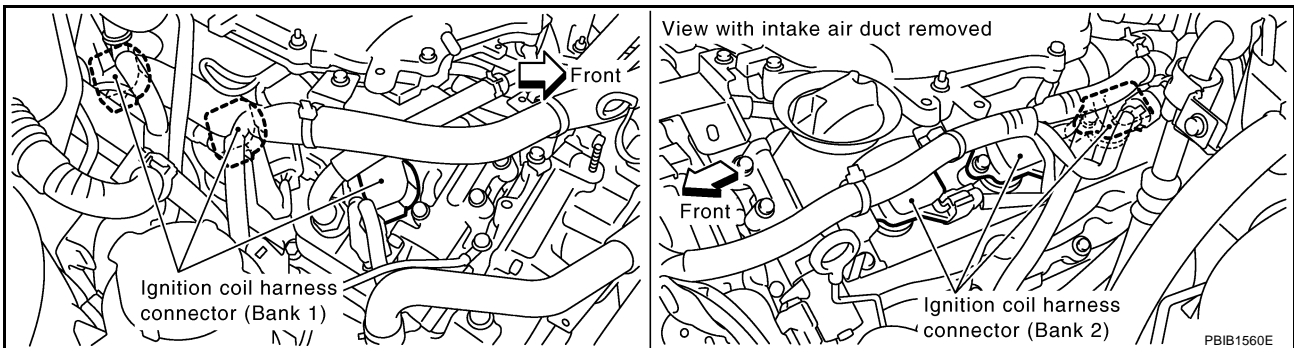

4. Turn ignition switch ON.
5. Check voltage between ignition coil terminal 3 and ground with CONSULT-II or tester.

Voltage: Battery voltage

OK or NG

OK >> GO TO 12.

NG >> GO TO 11.

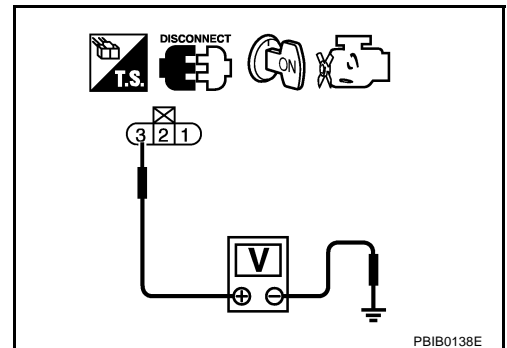

11. DETECT MALFUNCTIONING PART

Check the following.

- Harness connectors F10, F211
- Harness for open or short between ignition coil and harness connector F49

>> Repair or replace harness or connectors.

12. CHECK IGNITION COIL GROUND CIRCUIT FOR OPEN AND SHORT

1. Turn ignition switch OFF.
2. Check harness continuity between ignition coil terminal 2 and ground.
Refer to Wiring Diagram.

Continuity should exist.

3. Also check harness for short to power.

OK or NG

- OK >> GO TO 14.
NG >> GO TO 13.

13. DETECT MALFUNCTIONING PART

Check the following.

- Harness connectors F211, F10
- Harness for open or short between ignition coil and ground

>> Repair open circuit or short to power in harness or connectors.

14. CHECK IGNITION COIL OUTPUT SIGNAL CIRCUIT FOR OPEN AND SHORT

1. Disconnect ECM harness connector.
2. Check harness continuity between ECM terminals 60, 61, 62, 79, 80, 81 and ignition coil terminal 1.
Refer to Wiring Diagram.

Continuity should exist.

3. Also check harness for short to ground and short to power.

OK or NG

- OK >> GO TO 16.
NG >> GO TO 15.

15. DETECT MALFUNCTIONING PART

Check the following.

- Harness connectors F10, F211
- Harness for open or short between ignition coil and ECM

>> Repair open circuit or short to ground or short to power in harness or connectors.

16. CHECK IGNITION COIL WITH POWER TRANSISTOR

Refer to [EC-595, "Component Inspection"](#) .

OK or NG

- OK >> GO TO 17.
NG >> Replace ignition coil with power transistor.

17. CHECK INTERMITTENT INCIDENT

Refer to [EC-135, "TROUBLE DIAGNOSIS FOR INTERMITTENT INCIDENT"](#) .

>> **INSPECTION END**

Component Inspection
IGNITION COIL WITH POWER TRANSISTOR

1. Turn ignition switch OFF.

IGNITION SIGNAL

[VQ35DE]

2. Disconnect ignition coil harness connector.
3. Check resistance between ignition coil terminals as follows.

Terminal No. (Polarity)	Resistance Ω [at 25°C (77°F)]
1 and 2	Except 0 or ∞
1 and 3	Except 0
2 and 3	

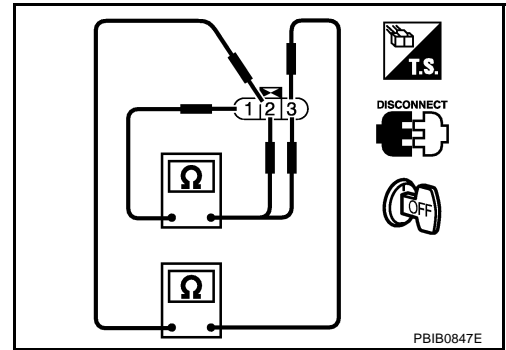

CONDENSER

1. Turn ignition switch OFF.
2. Disconnect condenser harness connector.
3. Check resistance between condenser terminals 1 and 2.

Resistance	Above 1 M Ω at 25°C (77°F)
------------	-----------------------------------

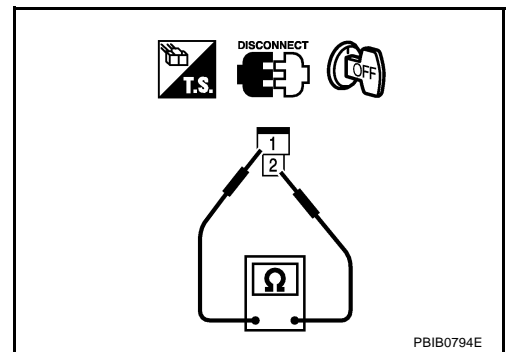

Removal and Installation IGNITION COIL WITH POWER TRANSISTOR

Refer to [EM-42, "IGNITION COIL"](#).

ABS006Y8

INJECTOR CIRCUIT

PFP:16600

Component Description

ABS006Y9

The fuel injector is a small, precise solenoid valve. When the ECM supplies a ground to the injector circuit, the coil in the injector is energized. The energized coil pulls the ball valve back and allows fuel to flow through the injector into the intake manifold. The amount of fuel injected depends upon the injection pulse duration. Pulse duration is the length of time the injector remains open. The ECM controls the injection pulse duration based on engine fuel needs.

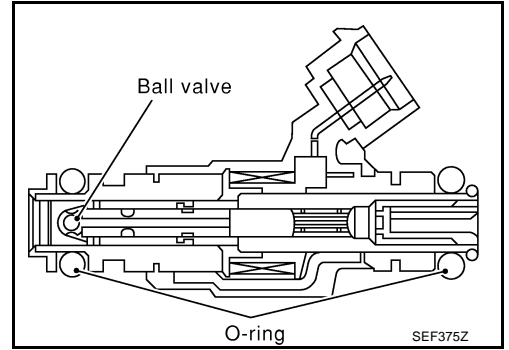

CONSULT-II Reference Value in Data Monitor Mode

ABS006YA

Specification data are reference values.

MONITOR ITEM	CONDITION	SPECIFICATION
B/FUEL SCHDL	See EC-131 , "TROUBLE DIAGNOSIS - SPECIFICATION VALUE".	
INJ PULSE-B1 INJ PULSE-B2	● Engine: After warming up ● Shift lever: P or N Idle	2.0 - 3.0 msec
	● Air conditioner switch: OFF ● No-load 2,000 rpm	1.9 - 2.9 msec

INJECTOR CIRCUIT

[VQ35DE]

ABS006YB

Wiring Diagram

EC-INJECT-01

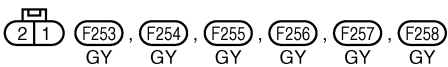
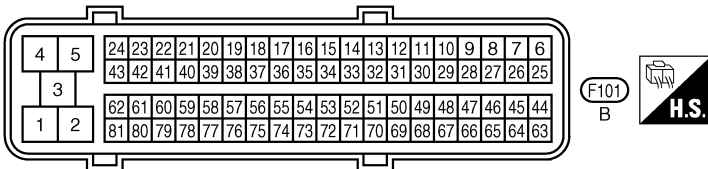
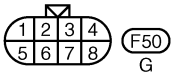
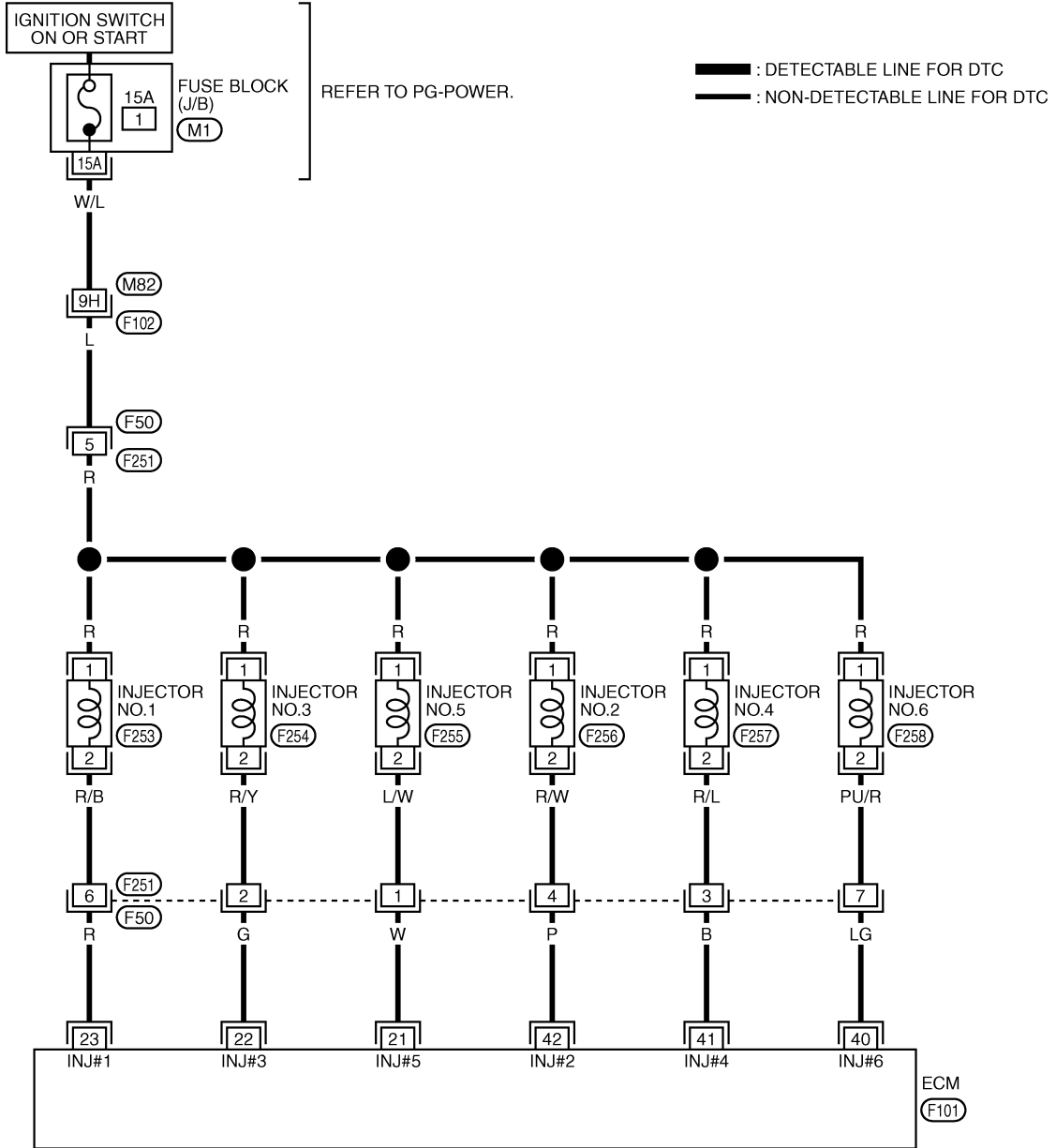

REFER TO THE FOLLOWING.

(F102) -SUPER MULTIPLE JUNCTION (SMJ)

(M1) -FUSE BLOCK-JUNCTION BOX (J/B)

TBWM0310E

INJECTOR CIRCUIT

[VQ35DE]

Specification data are reference values and are measured between each terminal and ground.
Pulse signal is measured by CONSULT-II.

CAUTION:

Do not use ECM ground terminals when measuring input/output voltage. Doing so may result in damage to the ECM's transistor. Use a ground other than ECM terminals, such as the ground.

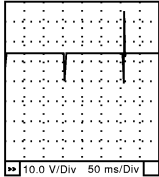
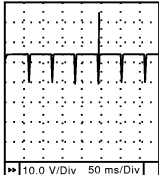
TER-MINAL NO.	WIRE COLOR	ITEM	CONDITION	DATA (DC Voltage)	
21	W	Injector No. 5	<p>[Engine is running]</p> <ul style="list-style-type: none"> ● Warm-up condition ● Idle speed <p>NOTE: The pulse cycle changes depending on rpm at idle</p>	<p>BATTERY VOLTAGE (11 - 14V)★</p>  <p>SEC984C</p>	
22	G	Injector No. 3		<p>[Engine is running]</p> <ul style="list-style-type: none"> ● Warm-up condition ● Engine speed is 2,000 rpm 	<p>BATTERY VOLTAGE (11 - 14V)★</p>  <p>SEC985C</p>
23	R	Injector No. 1			
40	LG	Injector No. 6			
41	B	Injector No. 4			
42	P	Injector No. 2			

★: Average voltage for pulse signal (Actual pulse signal can be confirmed by oscilloscope.)

Diagnostic Procedure

ABS006YC

1. INSPECTION START

Turn ignition switch to START.

Is any cylinder ignited?

Yes or No

- Yes >> GO TO 2.
- No >> GO TO 3.

2. CHECK OVERALL FUNCTION

④ With CONSULT-II

1. Start engine.
2. Perform "POWER BALANCE" in "ACTIVE TEST" mode with CONSULT-II.
3. Make sure that each circuit produces a momentary engine speed drop.

ACTIVE TEST	
POWER BALANCE	
MONITOR	
ENG SPEED	XXX rpm
MAS A/F SE-B1	XXX V

PBIB0133E

⊗ Without CONSULT-II

1. Start engine.
2. Listen to each injector operating sound.
Clicking noise should be heard.

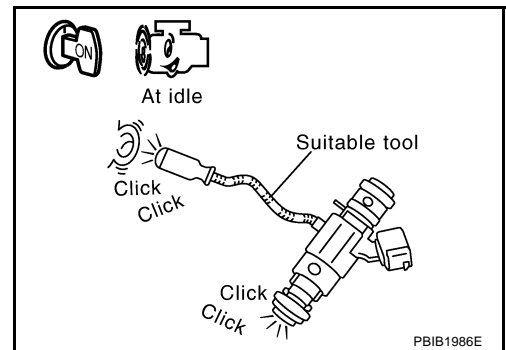

OK or NG

- OK >> **INSPECTION END**
 NG >> GO TO 3.

3. CHECK INJECTOR POWER SUPPLY CIRCUIT

1. Turn ignition switch OFF.
2. Disconnect injector harness connector.
3. Turn ignition switch ON.

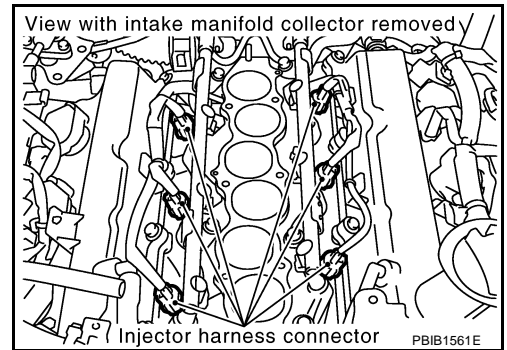

4. Check voltage between injector terminal 1 and ground with CONSULT-II or tester.

Voltage: Battery voltage

OK or NG

- OK >> GO TO 5.
- NG >> GO TO 4.

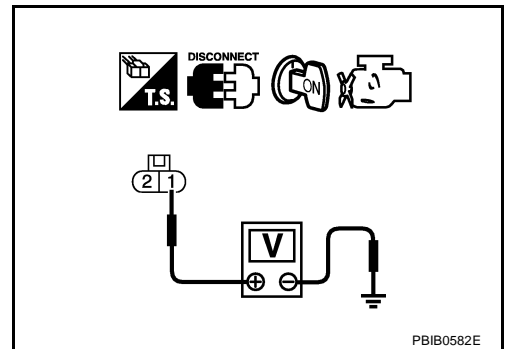

4. DETECT MALFUNCTIONING PART

Check the following.

- Harness connectors M82, F102
- Harness connectors F50, F251
- Fuse block (J/B) connector M1
- 15A fuse
- Harness for open or short between injector and fuse

>> Repair harness or connectors.

5. CHECK INJECTOR OUTPUT SIGNAL CIRCUIT FOR OPEN AND SHORT

1. Turn ignition switch OFF.
2. Disconnect ECM harness connector.
3. Check harness continuity between injector terminal 2 and ECM terminals 21, 22, 23, 40, 41, 42. Refer to Wiring Diagram.

Continuity should exist.

4. Also check harness for short to ground and short to power.

OK or NG

- OK >> GO TO 7.
- NG >> GO TO 6.

6. DETECT MALFUNCTIONING PART

Check the following.

- Harness connectors F50, F251
- Harness for open or short between injector and ECM

>> Repair open circuit or short to ground or short to power in harness or connectors.

7. CHECK INJECTOR

Refer to [EC-602, "Component Inspection"](#) .

OK or NG

OK >> GO TO 8.

NG >> Replace injector.

8. CHECK INTERMITTENT INCIDENT

Refer to [EC-135, "TROUBLE DIAGNOSIS FOR INTERMITTENT INCIDENT"](#) .

>> INSPECTION END

Component Inspection INJECTOR

ABS006YD

1. Disconnect injector harness connector.
2. Check resistance between terminals as shown in the figure.

Resistance: 13.5 - 17.5Ω [at 10 - 60°C (50 - 140°F)]

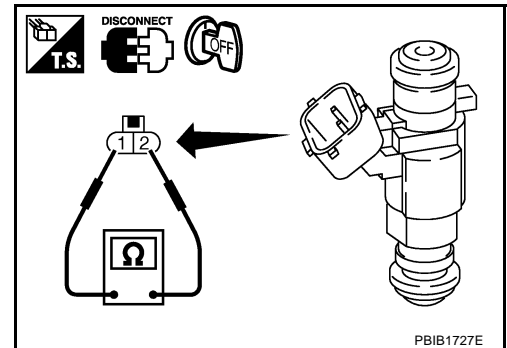

ABS006YE

Removal and Installation INJECTOR

Refer to [EM-45, "FUEL INJECTOR AND FUEL TUBE"](#) .

FUEL PUMP CIRCUIT

[VQ35DE]

FUEL PUMP CIRCUIT

PF:17042

Description SYSTEM DESCRIPTION

ABS006YF

Sensor	Input Signal to ECM	ECM Function	Actuator
Crankshaft position sensor (POS) Camshaft position sensor (PHASE)	Engine speed*	Fuel pump control	Fuel pump relay
Battery	Battery voltage*		

*: ECM determines the start signal status by the signals of engine speed and battery voltage.

The ECM activates the fuel pump for several seconds after the ignition switch is turned ON to improve engine start ability. If the ECM receives a engine speed signal from the camshaft position sensor (PHASE), it knows that the engine is rotating, and causes the pump to operate. If the engine speed signal is not received when the ignition switch is ON, the engine stalls. The ECM stops pump operation and prevents battery discharging, thereby improving safety. The ECM does not directly drive the fuel pump. It controls the ON/OFF fuel pump relay, which in turn controls the fuel pump.

Condition	Fuel pump operation
Ignition switch is turned to ON.	Operates for 1 second.
Engine running and cranking	Operates.
When engine is stopped	Stops in 1.5 seconds.
Except as shown above	Stops.

COMPONENT DESCRIPTION

A turbine type design fuel pump is used in the fuel tank.

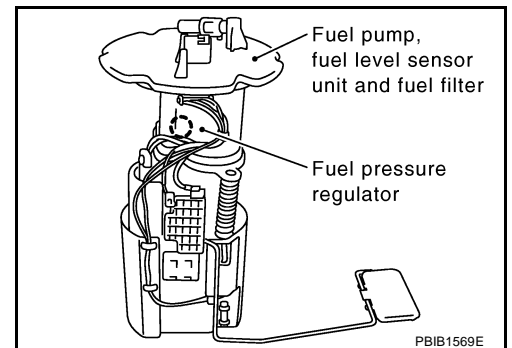

CONSULT-II Reference Value in Data Monitor Mode

ABS006YG

Specification data are reference values.

MONITOR ITEM	CONDITION	SPECIFICATION
FUEL PUMP RLY	<ul style="list-style-type: none"> For 1 second after turning ignition switch ON Engine running or cranking 	ON
	<ul style="list-style-type: none"> Except above conditions 	OFF

FUEL PUMP CIRCUIT

[VQ35DE]

ABS006YH

Wiring Diagram

EC-F/PUMP-01

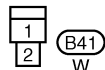
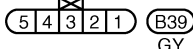
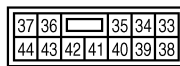
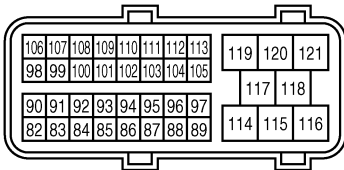
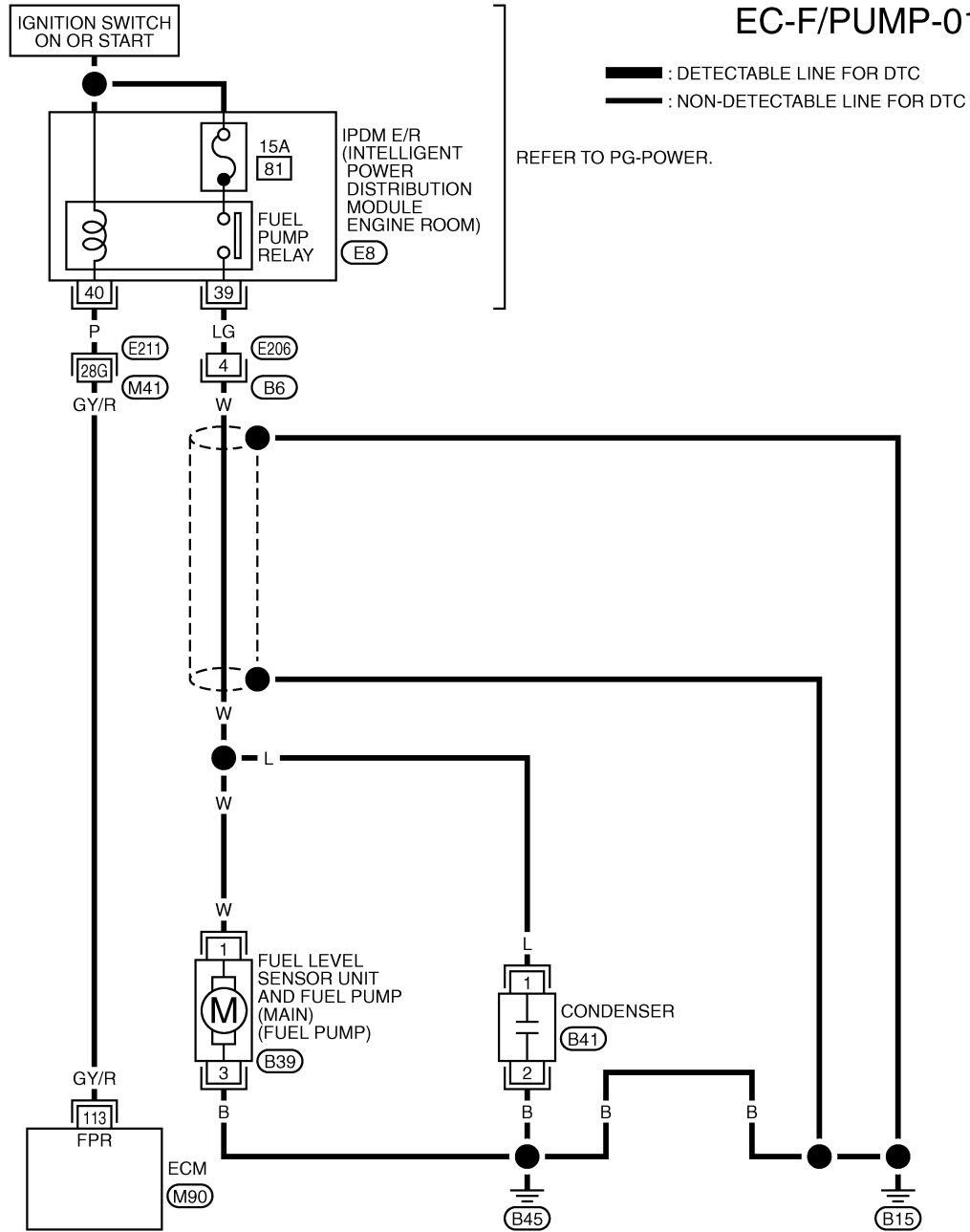

REFER TO THE FOLLOWING.

(E211) -SUPER MULTIPLE JUNCTION (SMJ)

TBWH0112E

FUEL PUMP CIRCUIT

[VQ35DE]

Specification data are reference values and are measured between each terminal and ground.

CAUTION:

Do not use ECM ground terminals when measuring input/output voltage. Doing so may result in damage to the ECM's transistor. Use a ground other than ECM terminals, such as the ground.

TER-MINAL NO.	WIRE COLOR	ITEM	CONDITION	DATA (DC Voltage)
113	GY/R	Fuel pump relay	[Ignition switch: ON] ● For 1 second after turning ignition switch ON [Engine is running]	0 - 1.5V
			[Ignition switch: ON] ● More than 1 second after turning ignition switch ON	BATTERY VOLTAGE (11 - 14V)

Diagnostic Procedure

ABS00D11

1. CHECK OVERALL FUNCTION

- Turn ignition switch ON.
- Pinch fuel feed hose with two fingers.
Fuel pressure pulsation should be felt on the fuel feed hose for 1 second after ignition switch is turned ON.

OK or NG

- OK >> **INSPECTION END**
 NG >> GO TO 2.

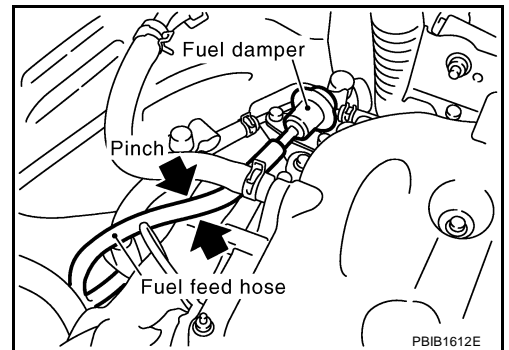

2. CHECK FUEL PUMP POWER SUPPLY CIRCUIT-I

- Turn ignition switch OFF.
- Disconnect ECM harness connector.
- Turn ignition switch ON.
- Check voltage between ECM terminal 113 and ground with CONSULT-II or tester.

Voltage: Battery voltage

OK or NG

- OK >> GO TO 5.
 NG >> GO TO 3.

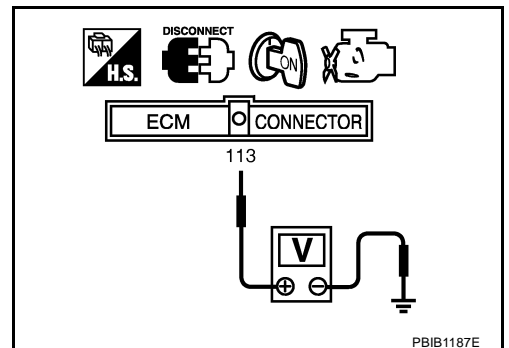

3. CHECK FUEL PUMP POWER SUPPLY CIRCUIT-II

Check voltage between IPDM E/R terminal 40 and ground with CONSULT-II or tester.

Voltage: Battery voltage

OK or NG

- OK >> GO TO 4.
- NG >> GO TO 14.

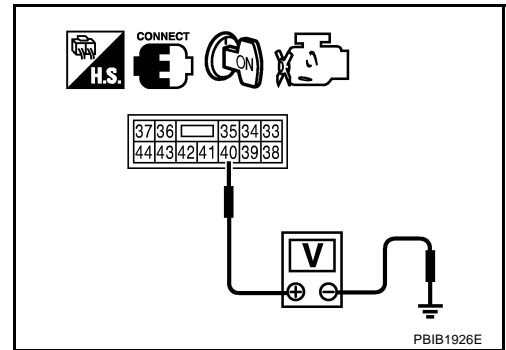

4. DETECT MALFUNCTIONING PART

Check the following.

- Harness connectors E211, M41
- Harness for open or short between IPDM E/R and ECM

>> Repair harness or connectors.

5. CHECK CONDENSER POWER SUPPLY CIRCUIT-I

1. Turn ignition switch OFF.
2. Reconnect all harness connectors disconnected.
3. Disconnect condenser harness connector.
4. Turn ignition switch ON.
5. Check voltage between condenser terminal 1 and ground with CONSULT-II or tester.

Voltage: Battery voltage should exist for 1 second after ignition switch is turned ON.

6. Also check harness for short to ground and short to power.

OK or NG

- OK >> GO TO 9.
- NG >> GO TO 6.

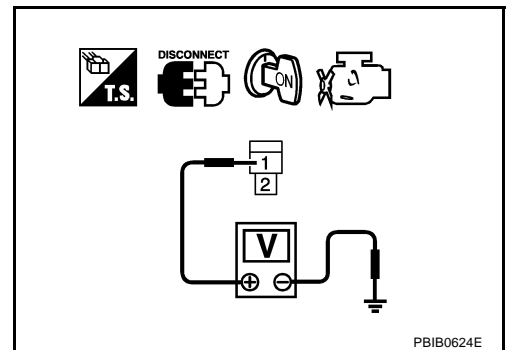

6. CHECK 15A FUSE

1. Turn ignition switch OFF.
2. Disconnect 15A fuse.
3. Check 15A fuse.

OK or NG

- OK >> GO TO 7.
- NG >> Replace fuse.

7. CHECK CONDENSER POWER SUPPLY CIRCUIT-II

1. Disconnect IPDM E/R harness connector E8.
2. Check harness continuity between IPDM E/R terminal 39 and condenser terminal 1.
Refer to Wiring Diagram.

Continuity should exist.

3. Also check harness for short to ground and short to power.

OK or NG

- OK >> GO TO 14.
- NG >> GO TO 8.

8. DETECT MALFUNCTIONING PART

Check the following.

- Harness connectors E206, B6
- Harness for open or short between IPDM E/R and condenser

>> Repair harness or connectors.

9. CHECK CONDENSER GROUND CIRCUIT

1. Check harness continuity between condenser terminal 2 and ground.
Refer to Wiring Diagram.

Continuity should exist.

2. Also check harness for short to power.

OK or NG

- OK >> GO TO 10.
- NG >> Repair open circuit or short to power in harness or connectors.

10. CHECK CONDENSER

Refer to [EC-608, "Component Inspection"](#) .

OK or NG

- OK >> GO TO 11.
- NG >> Replace condenser.

11. CHECK FUEL PUMP POWER SUPPLY AND GROUND CIRCUIT FOR OPEN AND SHORT

1. Turn ignition switch OFF.
2. Disconnect "fuel level sensor unit and fuel pump" harness connector.
3. Disconnect harness connector E206, B6.
4. Check harness continuity between "fuel level sensor unit and fuel pump" terminal 1 and harness connector B6 terminal 4, "fuel level sensor unit and fuel pump" terminal 3 and ground.
Refer to Wiring Diagram.

Continuity should exist.

5. Also check harness for short to ground and short to power.

OK or NG

- OK >> GO TO 13.
- NG >> GO TO 12.

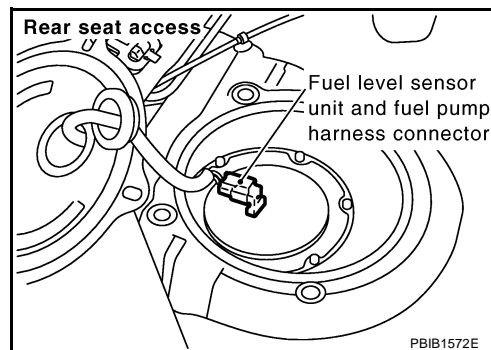

12. DETECT MALFUNCTIONING PART

Check the following.

- Harness connector B6
- Harness for open or short between “fuel level sensor unit and fuel pump” and harness connector B6
- Harness for open or short between “fuel level sensor unit and fuel pump” and ground

>> Repair open circuit or short to ground or short to power in harness or connectors.

13. CHECK FUEL PUMP

Refer to [EC-608, "Component Inspection"](#) .

OK or NG

OK >> GO TO 14.

NG >> Replace fuel pump.

14. CHECK INTERMITTENT INCIDENT

Refer to [EC-135, "TROUBLE DIAGNOSIS FOR INTERMITTENT INCIDENT"](#) .

OK or NG

OK >> Replace IPDM E/R.

NG >> Repair or replace harness or connectors.

Component Inspection FUEL PUMP

ABS006YJ

1. Disconnect “fuel level sensor unit and fuel pump” harness connector.
2. Check resistance between “fuel level sensor unit and fuel pump” terminals 1 and 3.

Resistance: Approximately 0.2 - 5.0Ω [at 25°C (77°F)]

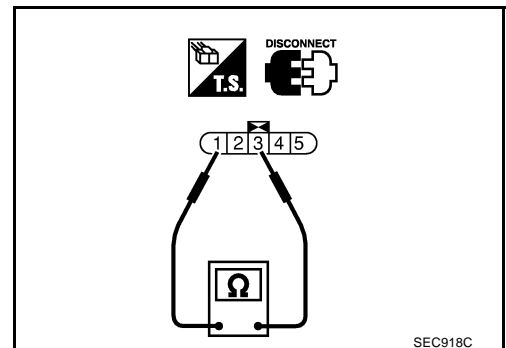

CONDENSER

1. Turn ignition switch OFF.
2. Disconnect condenser harness connector.
3. Check resistance between condenser terminals as 1 and 2.

Resistance	Above 1 MΩ at 25°C (77°F)
------------	---------------------------

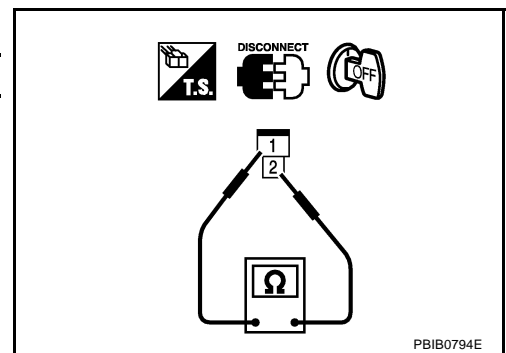

Removal and Installation FUEL PUMP

ABS006YK

Refer to [FL-4, "FUEL LEVEL SENSOR UNIT, FUEL FILTER AND FUEL PUMP ASSEMBLY"](#) .

REFRIGERANT PRESSURE SENSOR

PFP:92136

Component Description

ABS006YL

The refrigerant pressure sensor is installed at the condenser of the air conditioner system. The sensor uses an electrostatic volume pressure transducer to convert refrigerant pressure to voltage. The voltage signal is sent to ECM, and ECM controls cooling fan system.

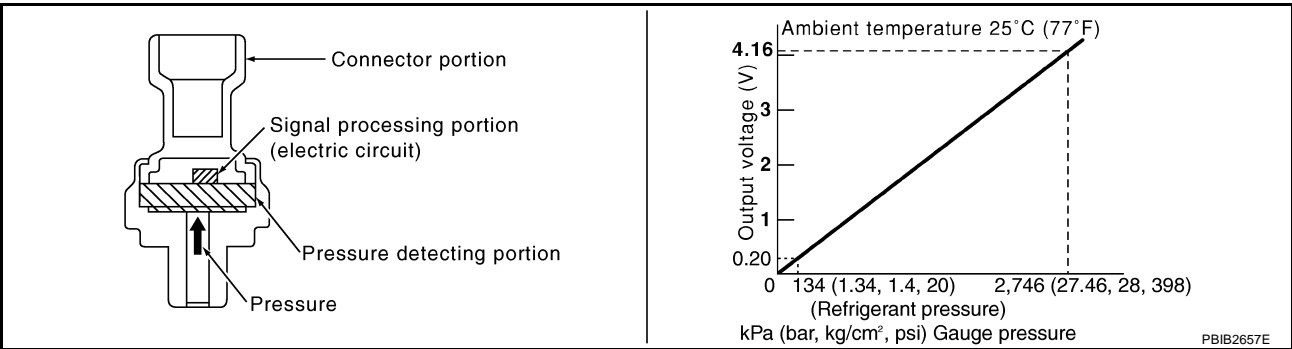
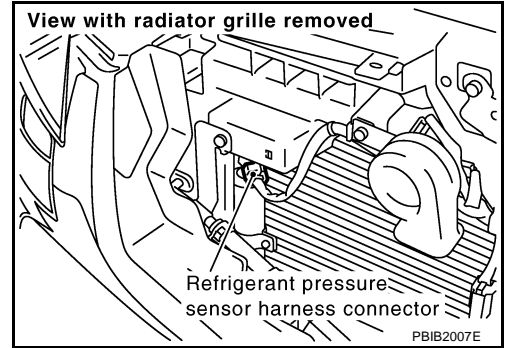

REFRIGERANT PRESSURE SENSOR

[VQ35DE]

Wiring Diagram

ABS006YM

EC-RP/SEN-01

: DETECTABLE LINE FOR DTC
 : NON-DETECTABLE LINE FOR DTC

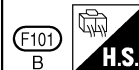
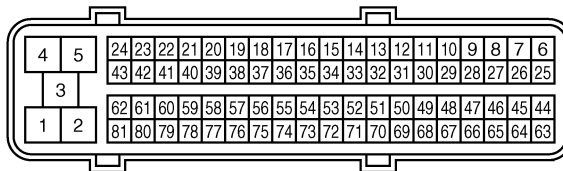
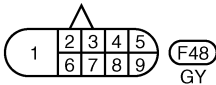
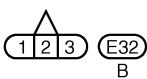
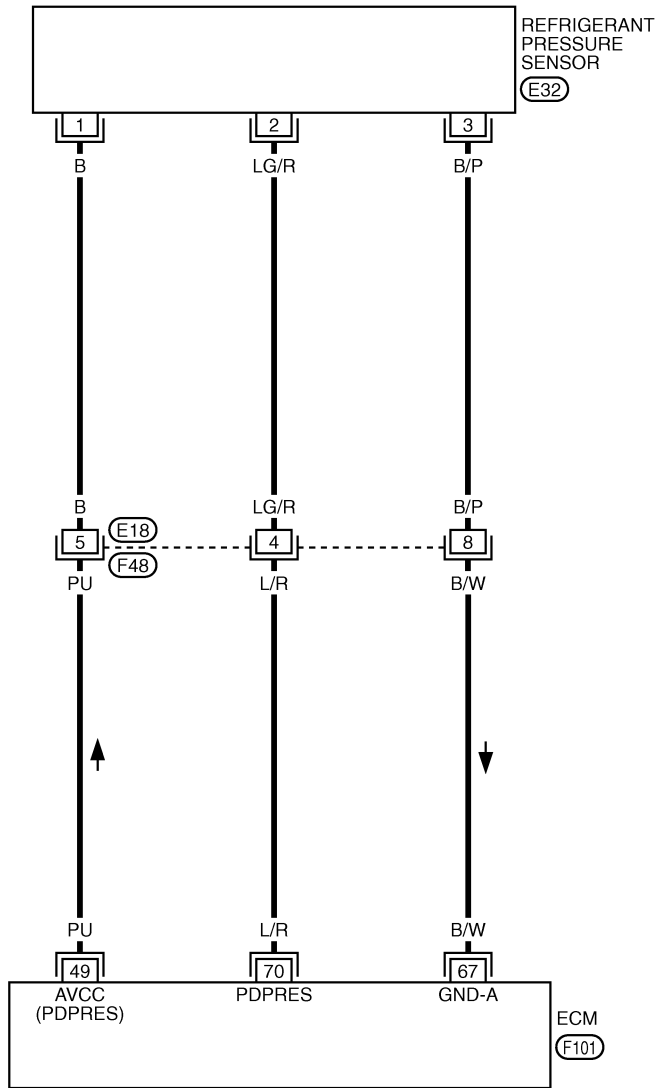

TBWM0312E

REFRIGERANT PRESSURE SENSOR

[VQ35DE]

Specification data are reference values and are measured between each terminal and ground.

CAUTION:

Do not use ECM ground terminals when measuring input/output voltage. Doing so may result in damage to the ECM's transistor. Use a ground other than ECM terminals, such as the ground.

TER-MINAL NO.	WIRE COLOR	ITEM	CONDITION	DATA (DC Voltage)
49	PU	Sensor power supply (Refrigerant pressure sensor)	[Ignition switch: ON]	Approximately 5V
67	B/W	Sensor ground (Refrigerant pressure sensor)	[Engine is running] ● Warm-up condition ● Idle speed	Approximately 0V
70	L/R	Refrigerant pressure sensor	[Engine is running] ● Warm-up condition ● Both A/C switch and blower switch are ON (Compressor operates)	1.0 - 4.0V

Diagnostic Procedure

ABS00CU

1. CHECK REFRIGERANT PRESSURE SENSOR OVERALL FUNCTION

1. Start engine and warm it up to normal operating temperature.
2. Turn A/C switch and blower switch ON.
3. Check voltage between ECM terminal 70 and ground with CONSULT-II or tester.

Voltage: 1.0 - 4.0V

OK or NG

- OK >> **INSPECTION END**
- NG >> GO TO 2.

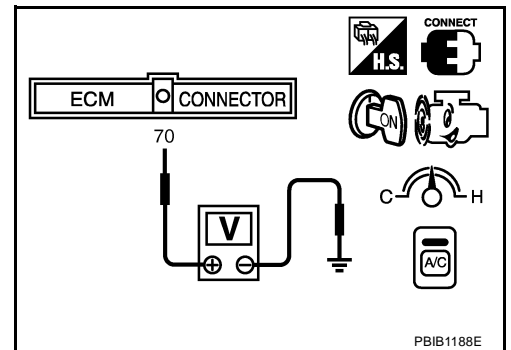

2. CHECK GROUND CONNECTIONS

1. Turn ignition switch OFF.
2. Loosen and retighten ground three screws on the body. Refer to [EC-141, "Ground Inspection"](#).

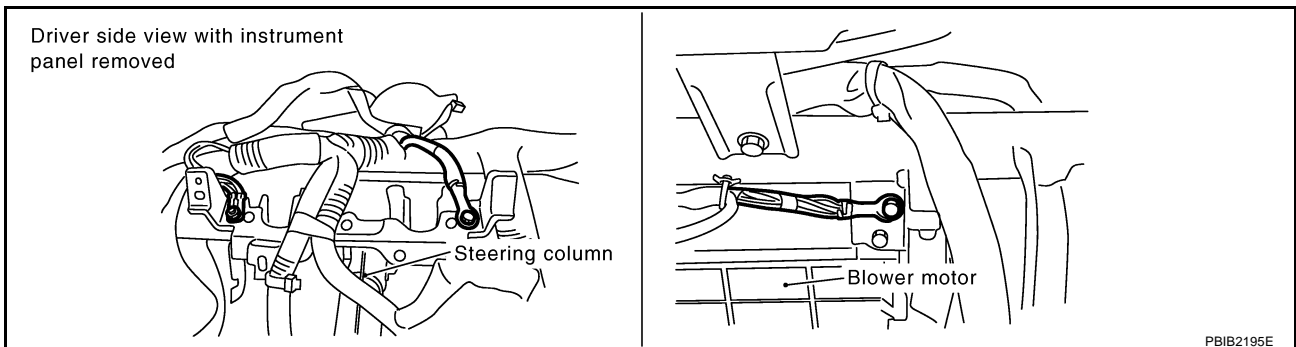

OK or NG

- OK >> GO TO 3.
- NG >> Repair or replace ground connections.

3. CHECK REFRIGERANT PRESSURE SENSOR POWER SUPPLY CIRCUIT

1. Turn A/C switch and blower switch OFF.
2. Disconnect refrigerant pressure sensor harness connector.
3. Turn ignition switch ON.

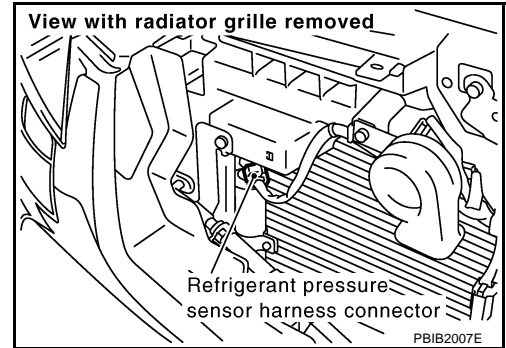

4. Check voltage between refrigerant pressure sensor terminal 1 and ground with CONSULT-II or tester.

Voltage: Approximately 5V

OK or NG

- OK >> GO TO 5.
- NG >> GO TO 4.

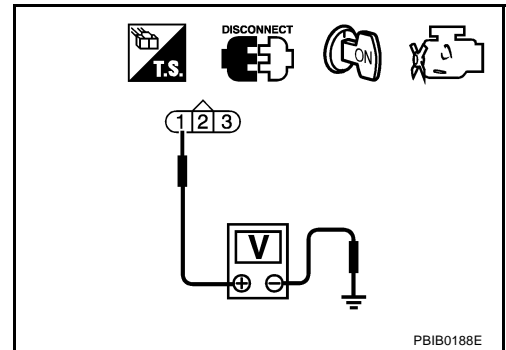

4. DETECT MALFUNCTIONING PART

Check the following.

- Harness connectors E18, F48
- Harness for open or short between ECM and refrigerant pressure sensor

>> Repair harness or connectors.

5. CHECK REFRIGERANT PRESSURE SENSOR GROUND CIRCUIT FOR OPEN AND SHORT

1. Turn ignition switch OFF.
2. Disconnect ECM harness connector.
3. Check harness continuity between refrigerant pressure sensor terminal 3 and ECM terminal 67. Refer to Wiring Diagram.

Continuity should exist.

4. Also check harness for short to ground and short to power.

OK or NG

- OK >> GO TO 7.
- NG >> GO TO 6.

6. DETECT MALFUNCTIONING PART

Check the following.

- Harness connectors E18, F48
- Harness for open or short between ECM and refrigerant pressure sensor

>> Repair open circuit or short to ground or short to power in harness or connectors.

7. CHECK REFRIGERANT PRESSURE SENSOR INPUT SIGNAL CIRCUIT FOR OPEN AND SHORT

1. Check harness continuity between ECM terminal 70 and refrigerant pressure sensor terminal 2.
Refer to Wiring Diagram.

Continuity should exist.

2. Also check harness for short to ground and short to power.

OK or NG

- OK >> GO TO 9.
NG >> GO TO 8.

8. DETECT MALFUNCTIONING PART

Check the following.

- Harness connectors E18, F48
- Harness for open or short between ECM and refrigerant pressure sensor

>> Repair open circuit or short to ground or short to power in harness or connectors.

9. CHECK INTERMITTENT INCIDENT

Refer to [EC-135, "TROUBLE DIAGNOSIS FOR INTERMITTENT INCIDENT"](#) .

OK or NG

- OK >> Replace refrigerant pressure sensor.
NG >> Repair or replace.

Removal and Installation
REFRIGERANT PRESSURE SENSOR

ABS006YO

Refer to [ATC-155, "Removal and Installation of Refrigerant Pressure Sensor"](#) .

ELECTRICAL LOAD SIGNAL

PFP:25350

Description

ABS006YP

The electrical load signal (Headlamp switch signal, etc.) is transferred through the CAN communication line from BCM to ECM via IPDM E/R.

CONSULT-II Reference Value in Data Monitor Mode

ABS006YQ

Specification data are reference values.

MONITOR ITEM	CONDITION	SPECIFICATION
LOAD SIGNAL	● Ignition switch: ON	ON
	Rear window defogger switch is ON and/or lighting switch is in 2nd.	ON
	Rear window defogger switch is OFF and lighting switch is OFF.	OFF

Diagnostic Procedure

ABS006YR

1. CHECK LOAD SIGNAL CIRCUIT OVERALL FUNCTION-I

1. Turn ignition switch ON.
2. Connect CONSULT-II and select "DATA MONITOR" mode.
3. Select "LOAD SIGNAL" and check indication under the following conditions.

Condition	Indication
Rear window defogger switch ON	ON
Rear window defogger switch OFF	OFF

OK or NG

- OK >> GO TO 2.
 NG >> GO TO 3.

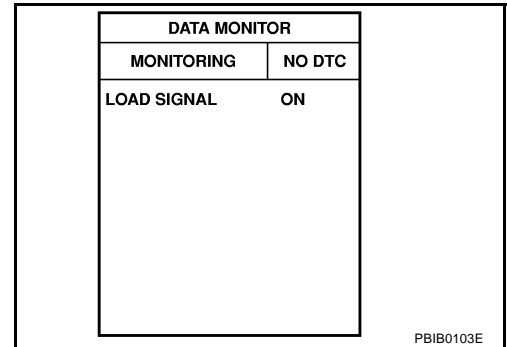

2. CHECK LOAD SIGNAL CIRCUIT OVERALL FUNCTION-II

Check "LOAD SIGNAL" indication under the following conditions.

Condition	Indication
Lighting switch ON at 2nd position	ON
Lighting switch OFF	OFF

OK or NG

- OK >> **INSPECTION END**
 NG >> GO TO 4.

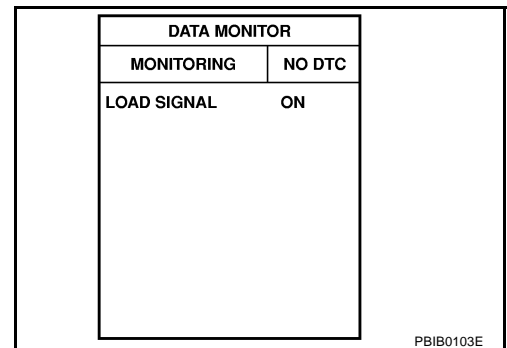

3. CHECK REAR WINDOW DEFOGGER SYSTEM

Refer to [GW-86, "REAR WINDOW DEFOGGER"](#) .

>> **INSPECTION END**

4. CHECK HEADLAMP SYSTEM

Refer to [LT-7, "HEADLAMP - XENON TYPE -"](#) .

>> **INSPECTION END**

ICC BRAKE SWITCH

[VQ35DE]

ICC BRAKE SWITCH

PPF:25320

Component Description

ABS006YS

When the brake pedal is depressed, ICC brake switch is turned OFF and stop lamp switch is turned ON. ECM detects the state of the brake pedal by this input of two kinds (ON/OFF signal)
Refer to [ACS-6, "DESCRIPTION"](#) for the ICC function.

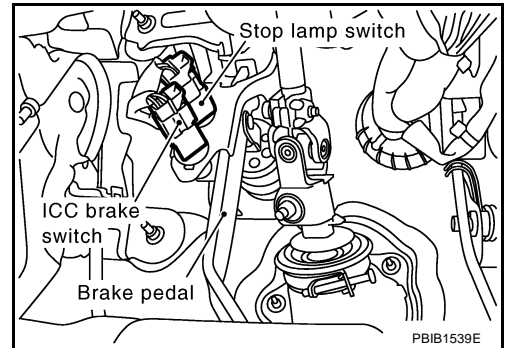

CONSULT-II Reference Value in Data Monitor Mode

ABS006YT

Specification data are reference values.

MONITOR ITEM	CONDITION		SPECIFICATION
BRAKE SW1 (ICC brake switch)	● Ignition switch: ON	● Brake pedal: Fully released	ON
		● Brake pedal: Slightly depressed	OFF
BRAKE SW2 (stop lamp switch)	● Ignition switch: ON	● Brake pedal: Fully released	OFF
		● Brake pedal: Slightly depressed	ON

ICC BRAKE SWITCH

[VQ35DE]

ABS006YU

Wiring Diagram

— : DETECTABLE LINE FOR DTC
 - - - : NON-DETECTABLE LINE FOR DTC

EC-ICCB0F-01

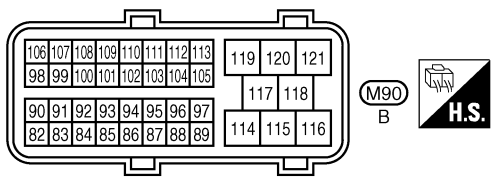
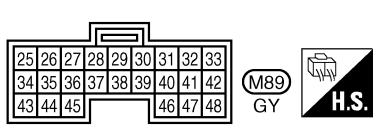
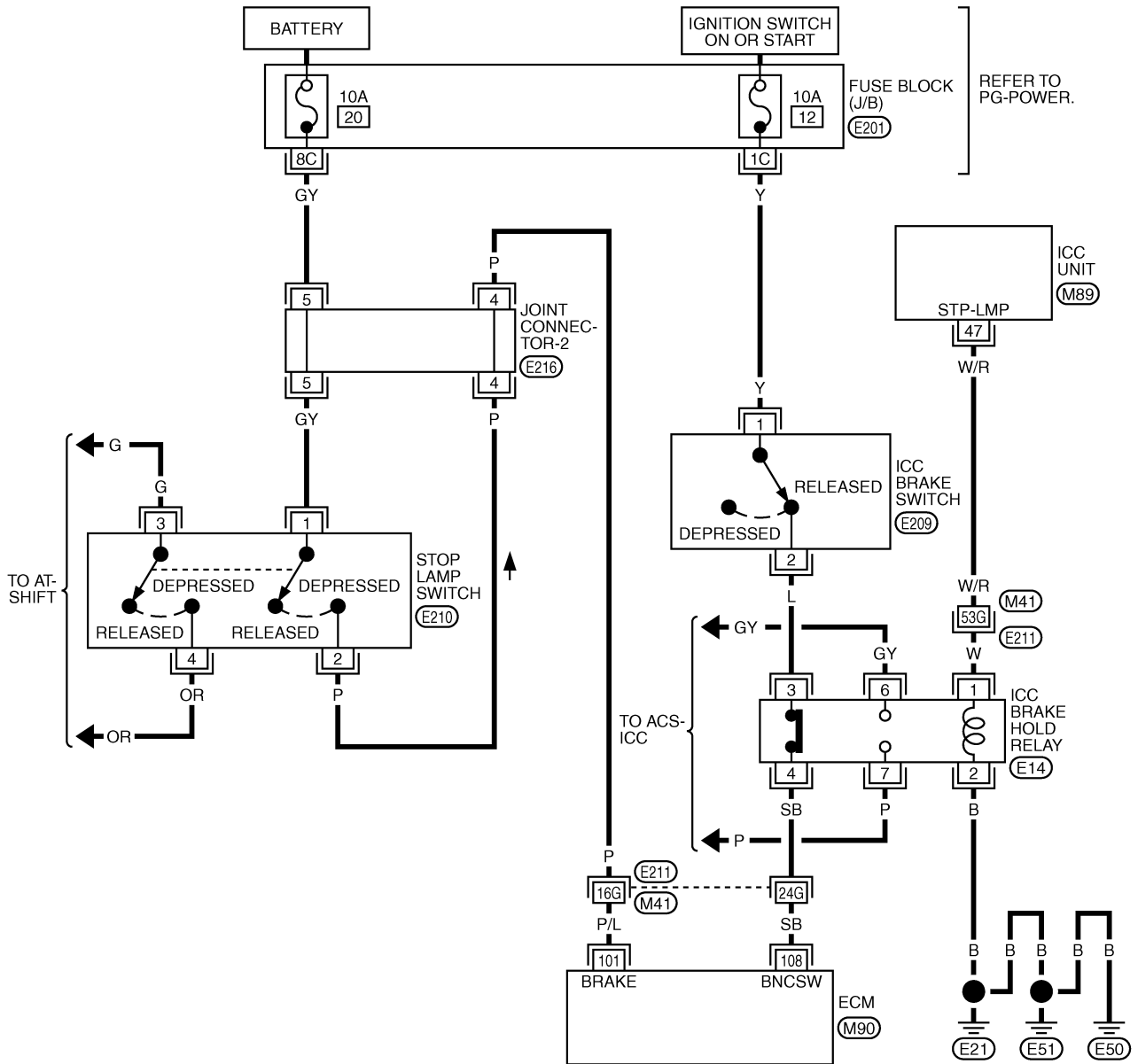

REFER TO THE FOLLOWING.
 (E21) -SUPER MULTIPLE JUNCTION (SMJ)
 (E201) -FUSE BLOCK-JUNCTION BOX (J/B)

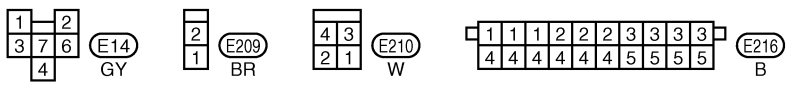

TBWM0275E

ICC BRAKE SWITCH

[VQ35DE]

Specification data are reference values and are measured between each terminal and ground.

CAUTION:

Do not use ECM ground terminals when measuring input/output voltage. Doing so may result in damage to the ECM's transistor. Use a ground other than ECM terminals, such as the ground.

TERMI- NAL NO.	WIRE COLOR	ITEM	CONDITION	DATA (DC Voltage)
101	P/L	Stop lamp switch	[Ignition switch: OFF] ● Brake pedal: Fully released	Approximately 0V
			[Ignition switch: OFF] ● Brake pedal: Slightly depressed	BATTERY VOLTAGE (11 - 14V)
108	SB	ICC brake switch	[Ignition switch: ON] ● Brake pedal: Slightly depressed	Approximately 0V
			[Ignition switch: ON] ● Brake pedal: Fully released	BATTERY VOLTAGE (11 - 14V)

Diagnostic Procedure

ABS00DAJ

1. CHECK OVERALL FUNCTION-I

With CONSULT-II

- Turn ignition switch "ON".
- Select "BRAKE SW1" in "DATA MONITOR" mode with CONSULT-II.
- Check "BRAKE SW1" indication under the following conditions.

CONDITION	INDICATION
When brake pedal is depressed	OFF
When brake pedal is fully released	ON

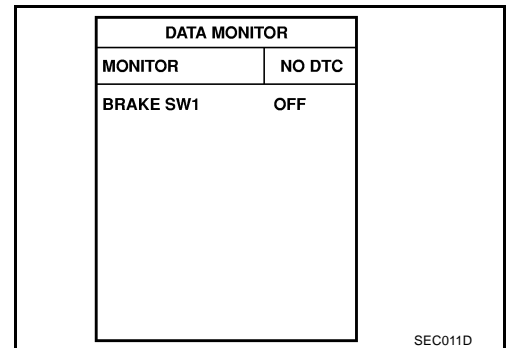

Without CONSULT-II

- Turn ignition switch "ON".
- Check voltage between ECM terminal 108 and ground under the following conditions.

CONDITION	VOLTAGE
When brake pedal is depressed	Approximately 0V
When brake pedal is fully released	Battery voltage

OK or NG

- OK >> GO TO 2.
NG >> GO TO 3.

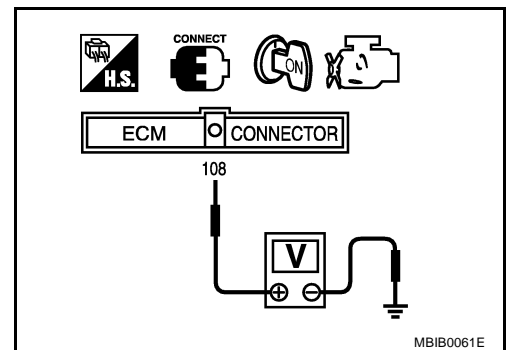

2. CHECK OVERALL FUNCTION-II

With CONSULT-II

Check "BRAKE SW2" indication in "DATA MONITOR" mode.

CONDITION	INDICATION
When brake pedal is released	OFF
When brake pedal is depressed	ON

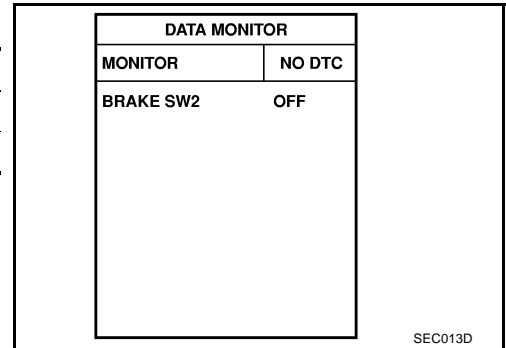

Without CONSULT-II

Check voltage between ECM terminal 101 and ground under the following conditions.

CONDITION	VOLTAGE
When brake pedal is released	Approximately 0V
When brake pedal is depressed	Battery voltage

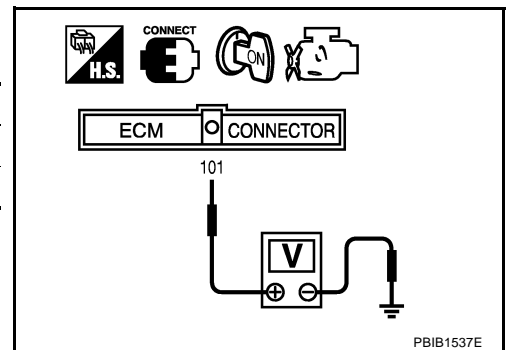

OK or NG

- OK >> **INSPECTION END**
- NG >> GO TO 12.

3. CHECK DTC WITH ICC UNIT

Refer to [ACS-40, "TROUBLE DIAGNOSIS FOR SELF-DIAGNOSTIC ITEMS"](#) .

OK or NG

- OK >> GO TO 4.
- NG >> Repair or replace.

4. CHECK ICC BRAKE SWITCH CIRCUIT

1. Turn ignition switch "OFF".
2. Disconnect ICC brake hold relay.
3. Turn ignition switch "ON".

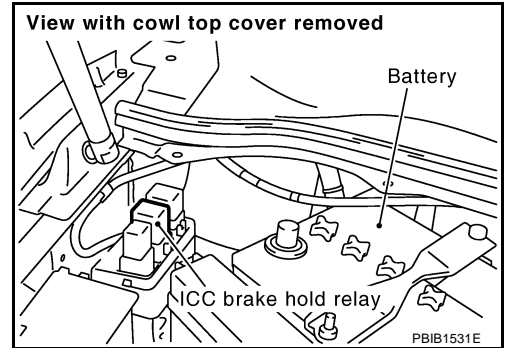

4. Check voltage between ICC brake hold relay terminal 3 and ground with CONSULT-II or tester.

Voltage: Battery voltage

OK or NG

- OK >> GO TO 9.
- NG >> GO TO 5.

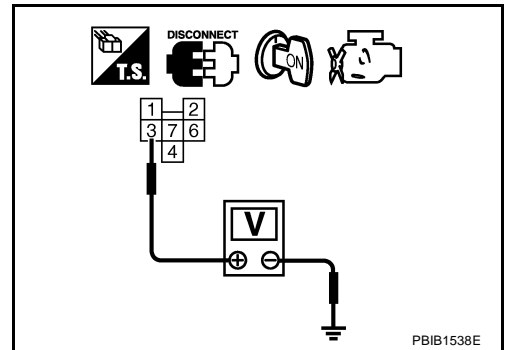

5. CHECK ICC BRAKE SWITCH POWER SUPPLY CIRCUIT

1. Turn ignition switch "OFF".
2. Disconnect ICC brake switch harness connector.
3. Turn ignition switch "ON".

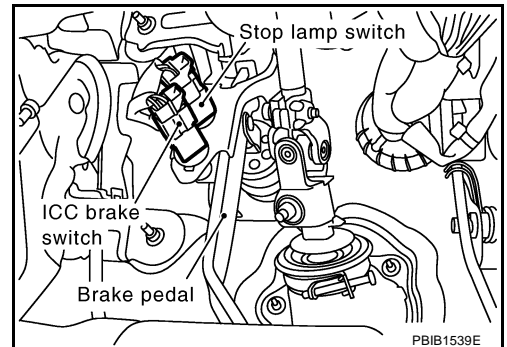

4. Check voltage between ICC brake switch terminal 1 and ground with CONSULT-II or tester.

Voltage: Battery voltage

OK or NG

- OK >> GO TO 7.
- NG >> GO TO 6.

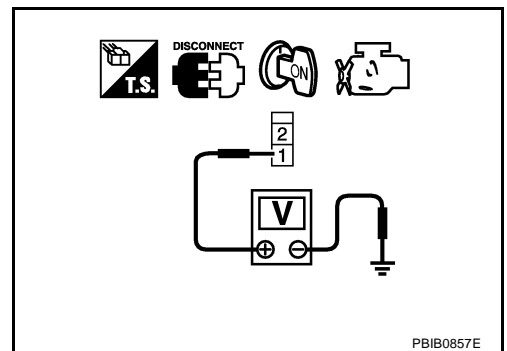

6. DETECT MALFUNCTIONING PART

Check the following.

- Fuse block (J/B) connector E201
- 10A fuse
- Harness for open or short between ICC brake switch and fuse

>> Repair open circuit or short to ground or short to power in harness or connectors.

7. CHECK ICC BRAKE SWITCH INPUT SIGNAL CIRCUIT FOR OPEN AND SHORT-I

1. Turn ignition switch "OFF".
2. Check harness continuity between ICC brake hold relay terminal 3 and ICC brake switch terminal 2. Refer to Wiring Diagram.

Continuity should exist.

3. Also check harness for short to ground and short to power.

OK or NG

OK >> GO TO 8.

NG >> Repair open circuit or short to ground or short to power in harness or connectors.

8. CHECK ICC BRAKE SWITCH

Refer to [EC-1301, "Component Inspection"](#) .

OK or NG

OK >> GO TO 17.

NG >> Replace ICC brake switch.

9. CHECK ICC BRAKE SWITCH INPUT SIGNAL CIRCUIT FOR OPEN AND SHORT-II

1. Turn ignition switch "OFF".
2. Disconnect ECM harness connector.
3. Check harness continuity between ICC brake hold relay terminal 4 and ECM terminal 108. Refer Wiring Diagram.

Continuity should exist.

4. Also check harness for short to ground and short to power.

OK or NG

OK >> GO TO 11.

NG >> GO TO 10.

10. DETECT MALFUNCTIONING PART

Check the following.

- Harness connectors E211, M41
- Harness for open or short between ICC brake hold relay and ECM

>> Repair open circuit or short to ground or short to power in harness or connectors.

11. CHECK ICC BRAKE HOLD RELAY

Refer to [EC-1301, "Component Inspection"](#) .

OK >> GO TO 17.

NG >> Replace ICC brake fold relay.

12. CHECK STOP LAMP SWITCH POWER SUPPLY CIRCUIT

1. Turn ignition switch "OFF".
2. Disconnect stop lamp switch harness connector.

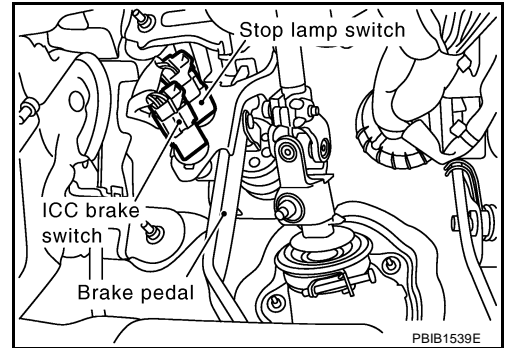

3. Check voltage between stop lamp switch terminal 1 and ground with CONSULT -II or tester.

Voltage: Battery voltage

OK or NG

- OK >> GO TO 14.
- NG >> GO TO 13.

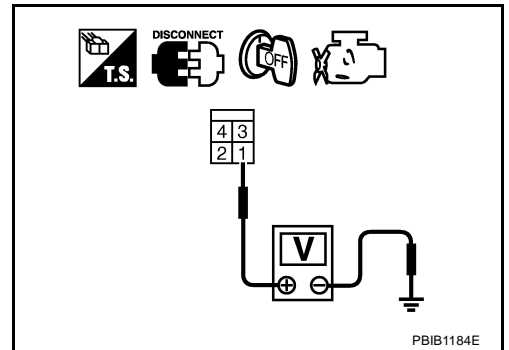

13. DETECT MALFUNCTIONING PART

Check the following.

- Joint connector-2
- Fuse block (J/B) connector E201
- 10A fuse
- Harness for open or short between stop lamp switch and fuse

>> Repair open circuit or short to ground or short to power in harness or connectors.

14. CHECK STOP LAMP SWITCH INPUT SIGNAL CIRCUIT FOR OPEN AND SHORT

1. Disconnect ECM harness connector.
2. Check harness continuity between ECM terminal 101 and stop lamp switch terminal 2. Refer to Wiring Diagram.

Continuity should exist.

3. Also check harness for short to ground and short to power.

OK or NG

- OK >> GO TO 16.
- NG >> GO TO 15.

15. DETECT MALFUNCTIONING PART

Check the following.

- Harness connectors E211, M41
- Joint connector-2
- Harness for open or short between ECM and stop lamp switch

>> Repair open circuit or short to ground or short to power in harness or connectors.

16. CHECK STOP LAMP SWITCH

Refer to [EC-1301, "Component Inspection"](#)

OK or NG

OK >> GO TO 17.

NG >> Replace stop lamp switch.

17. CHECK INTERMITTENT INCIDENT

Refer to [EC-784, "TROUBLE DIAGNOSIS FOR INTERMITTENT INCIDENT"](#) .

>> **INSPECTION END**

Component Inspection ICC BRAKE SWITCH

ABS006YW

1. Turn ignition switch OFF.
2. Disconnect ICC brake switch harness connector.
3. Check continuity between ICC brake switch terminals 1 and 2 under the following conditions.

Condition	Continuity
When brake pedal is fully released.	Should exist.
When brake pedal is slightly depressed.	Should not exist.

If NG, adjust ICC brake switch installation, refer to [BR-6, "BRAKE PEDAL"](#) , and perform step 3 again.

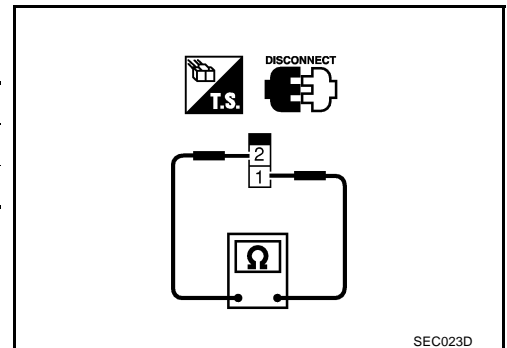

STOP LAMP SWITCH

1. Turn ignition switch OFF.
2. Disconnect stop lamp switch harness connector.
3. Check continuity between stop lamp switch terminals 1 and 2 under the following conditions.

Condition	Continuity
When brake pedal is fully released.	Should not exist.
When brake pedal is slightly depressed.	Should exist.

If NG, adjust stop lamp switch installation, refer to [BR-6, "BRAKE PEDAL"](#) , and perform step 3 again.

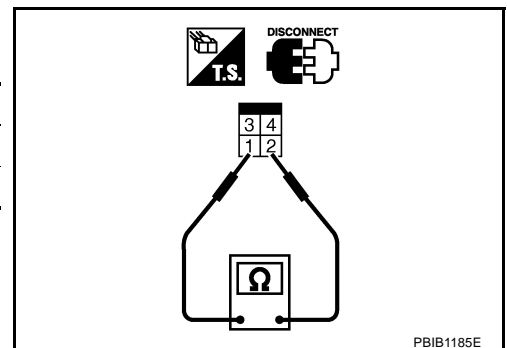

ICC BRAKE HOLD RELAY

1. Apply 12V direct current between ICC brake hold relay terminals 1 and 2.

ICC BRAKE SWITCH

[VQ35DE]

2. Check continuity between relay terminals 3 and 4, 6 and 7 under the following conditions.

Condition	Between terminals	Continuity
12V direct current supply between terminals 1 and 2	3 and 4	Should not exist
	6 and 7	Should exist
No current supply	3 and 4	Should exist
	6 and 7	Should not exist

3. If NG, replace ICC brake hold relay.

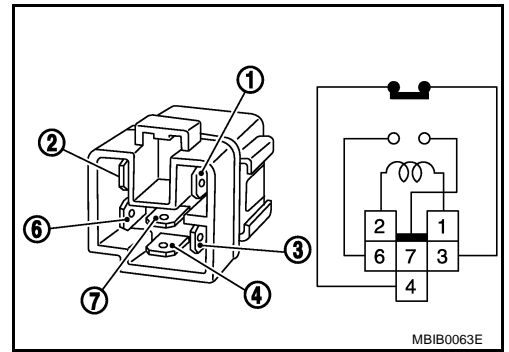

A

EC

C

D

E

F

G

H

I

J

K

L

M

ASC D BRAKE SWITCH

PFP:25320

Component Description

ABS006YX

When the brake pedal is depressed, ASCD brake switch is turned OFF and stop lamp switch is turned ON. ECM detects the state of the brake pedal by this input of two kinds (ON/OFF signal).

Refer to [EC-657, "AUTOMATIC SPEED CONTROL DEVICE \(ASC D\)"](#) for the ASCD function.

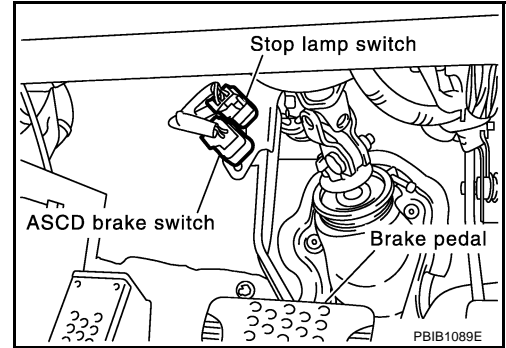

CONSULT-II Reference Value in Data Monitor Mode

ABS006YY

Specification data are reference values.

MONITOR ITEM	CONDITION		SPECIFICATION
BRAKE SW 1 (ASC D brake switch)	● Ignition switch: ON	● Brake pedal: Fully released	ON
		● Brake pedal: Slightly depressed	OFF
BRAKE SW 2 (stop lamp switch)	● Ignition switch: ON	● Brake pedal: Fully released	OFF
		● Brake pedal: Slightly depressed	ON

ASCD BRAKE SWITCH

[VQ35DE]

Wiring Diagram

ABS006YZ

EC-ASCBOF-01

— : DETECTABLE LINE FOR DTC
 — : NON-DETECTABLE LINE FOR DTC

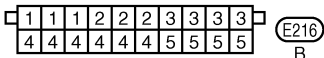
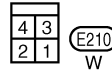
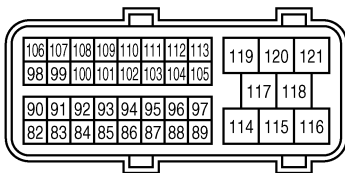
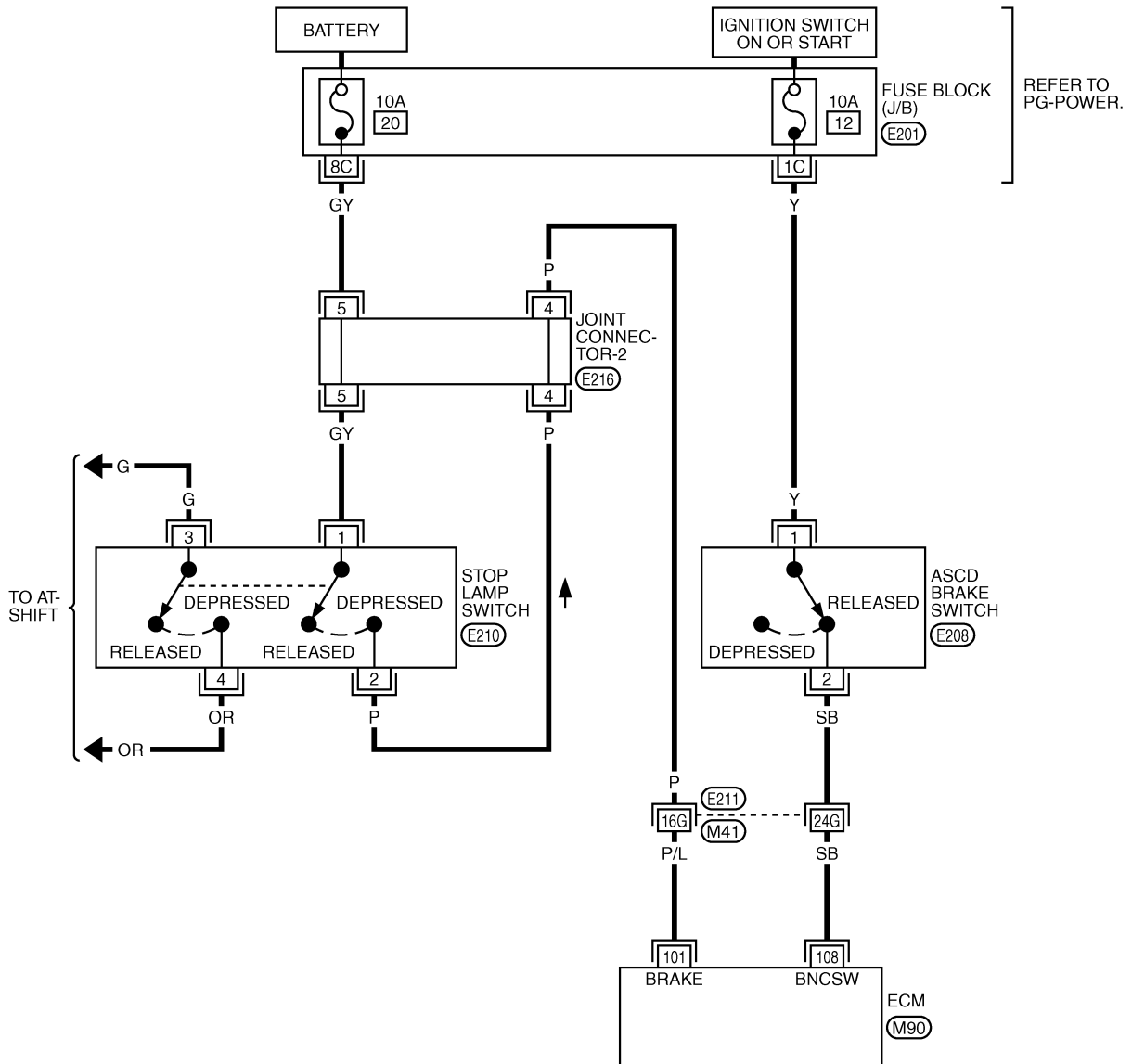

REFER TO THE FOLLOWING.

(E211) -SUPER MULTIPLE JUNCTION (SMJ)

(E201) -FUSE BLOCK-JUNCTION BOX (J/B)

TBWM0266E

ASCD BRAKE SWITCH

[VQ35DE]

Specification data are reference values and are measured between each terminal and ground.

CAUTION:

Do not use ECM ground terminals when measuring input/output voltage. Doing so may result in damage to the ECM's transistor. Use a ground other than ECM terminals, such as the ground.

TER-MINAL NO.	WIRE COLOR	ITEM	CONDITION	DATA (DC Voltage)
101	P/L	Stop lamp switch	[Ignition switch: OFF] ● Brake pedal: Fully released	Approximately 0V
			[Ignition switch: OFF] ● Brake pedal: Slightly depressed	BATTERY VOLTAGE (11 - 14V)
108	SB	ASCD brake switch	[Ignition switch: ON] ● Brake pedal: Slightly depressed	Approximately 0V
			[Ignition switch: ON] ● Brake pedal: Fully released	BATTERY VOLTAGE (11 - 14V)

Diagnostic Procedure

ABS006Z0

1. CHECK OVERALL FUNCTION-I

 **With CONSULT-II**

1. Turn ignition switch ON.
2. Select "BRAKE SW1" in "DATA MONITOR" mode with CONSULT-II.
3. Check "BRAKE SW1" indication under the following conditions.

CONDITION	INDICATION
When brake pedal is slightly depressed	OFF
When brake pedal is fully released	ON

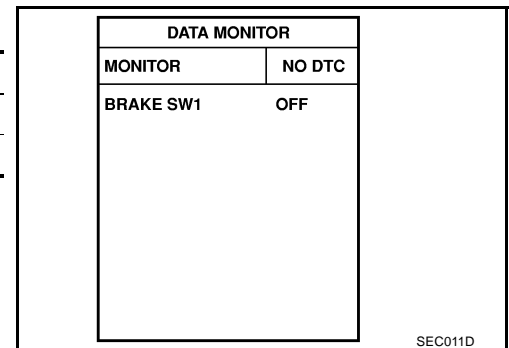

SEC011D

 **Without CONSULT-II**

1. Turn ignition switch ON.
2. Check voltage between ECM terminal 108 and ground under the following conditions.

CONDITION	VOLTAGE
When brake pedal is slightly depressed	Approximately 0V
When brake pedal is fully released	Battery voltage

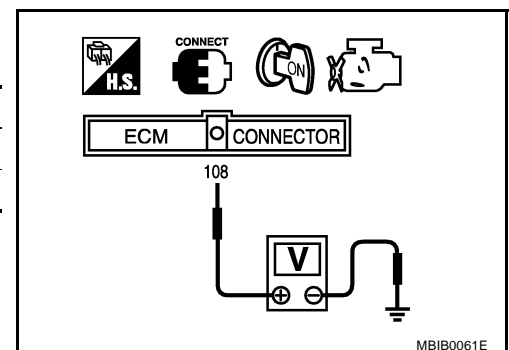

MBIB0061E

OK or NG

- OK >> GO TO 2.
 NG >> GO TO 3.

ASCD BRAKE SWITCH

[VQ35DE]

2. CHECK OVERALL FUNCTION-II

With CONSULT-II

Check "BRAKE SW2" indication in "DATA MONITOR" mode.

CONDITION	INDICATION
When brake pedal is fully released	OFF
When brake pedal is slightly depressed	ON

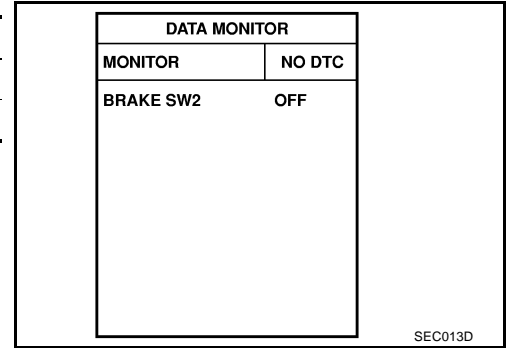

Without CONSULT-II

Check voltage between ECM terminal 101 and ground under the following conditions.

CONDITION	VOLTAGE
When brake pedal is fully released	Approximately 0V
When brake pedal is slightly depressed	Battery voltage

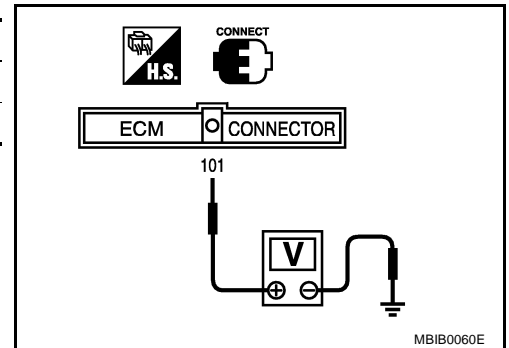

OK or NG

- OK >> **INSPECTION END**
- NG >> GO TO 8.

3. CHECK ASCD BRAKE SWITCH POWER SUPPLY CIRCUIT

1. Turn ignition switch OFF.
2. Disconnect ASCD brake switch harness connector.
3. Turn ignition switch ON.

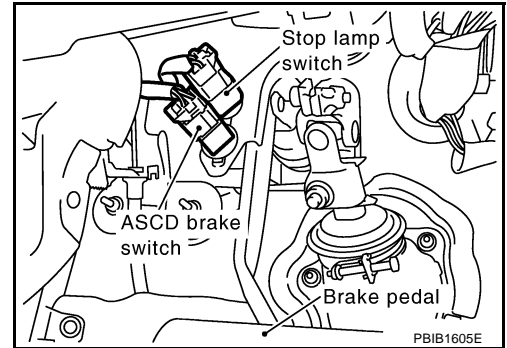

4. Check voltage between ASCD brake switch terminal 1 and ground with CONSULT-II or tester.

Voltage: Battery voltage

OK or NG

- OK >> GO TO 5.
- NG >> GO TO 4.

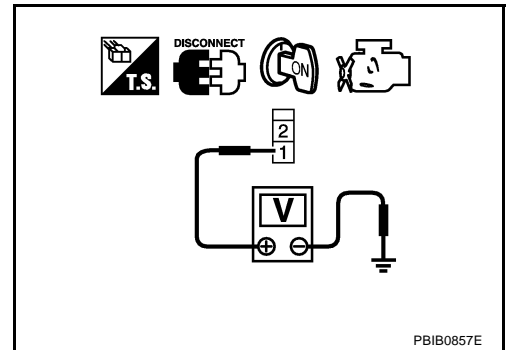

4. DETECT MALFUNCTIONING PART

Check the following.

- Fuse block (J/B) connector E201
- 10A fuse
- Harness for open or short between ASCD brake switch and fuse

>> Repair open circuit or short to ground in harness or connectors.

5. CHECK ASCD BRAKE SWITCH INPUT SIGNAL CIRCUIT FOR OPEN AND SHORT

1. Turn ignition switch OFF.
2. Disconnect ECM harness connector.
3. Check harness continuity between ECM terminal 108 and ASCD brake switch terminal 2. Refer to Wiring Diagram.

Continuity should exist.

4. Also check harness for short to ground and short to power.

OK or NG

- OK >> GO TO 7.
- NG >> GO TO 6.

6. DETECT MALFUNCTIONING PART

Check the following.

- Harness connectors E211, M41
- Harness for open or short between ECM and ASCD brake switch

>> Repair open circuit or short to ground in harness or connectors.

7. CHECK ASCD BRAKE SWITCH

Refer to [EC-631, "Component Inspection"](#)

OK or NG

- OK >> GO TO 13.
- NG >> Replace ASCD brake switch.

8. CHECK STOP LAMP SWITCH POWER SUPPLY CIRCUIT

1. Turn ignition switch OFF.
2. Disconnect stop lamp switch harness connector.

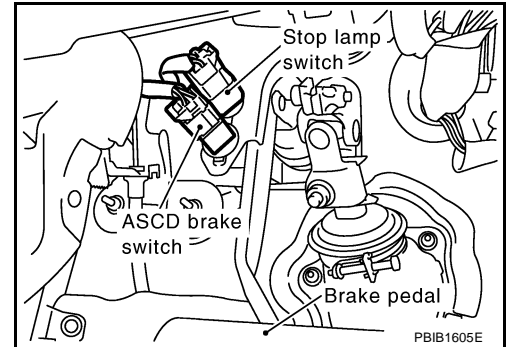

3. Check voltage between stop lamp switch terminal 1 and ground with CONSULT -II or tester.

Voltage: Battery voltage

OK or NG

- OK >> GO TO 10.
- NG >> GO TO 9.

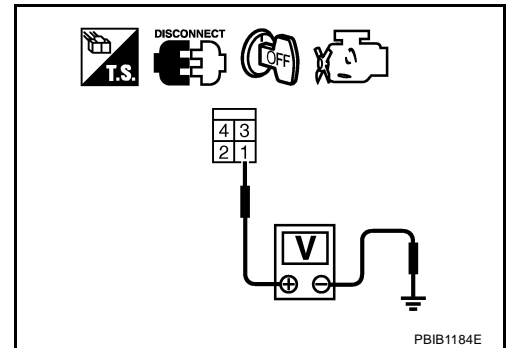

9. DETECT MALFUNCTIONING PART

Check the following.

- Fuse block (J/B) connector E201
- 10A fuse
- Joint connector-2
- Harness for open or short between stop lamp switch and battery

>> Repair open circuit or short to ground or short to power in harness or connectors.

10. CHECK STOP LAMP SWITCH INPUT SIGNAL CIRCUIT FOR OPEN AND SHORT

1. Disconnect ECM harness connector.
2. Check harness continuity between ECM terminal 101 and stop lamp switch terminal 2. Refer to Wiring Diagram.

Continuity should exist.

3. Also check harness for short to ground and short to power.

OK or NG

- OK >> GO TO 12.
- NG >> GO TO 11.

11. DETECT MALFUNCTIONING PART

Check the following.

- Harness connectors E211, M41
- Joint connector-2
- Harness for open or short between ECM and stop lamp switch

>> Repair open circuit or short to ground or short to power in harness or connectors.

12. CHECK STOP LAMP SWITCH

Refer to [EC-631, "Component Inspection"](#)

OK or NG

OK >> GO TO 13.

NG >> Replace stop lamp switch.

13. CHECK INTERMITTENT INCIDENT

Refer to [EC-135, "TROUBLE DIAGNOSIS FOR INTERMITTENT INCIDENT"](#) .

>> **INSPECTION END**

Component Inspection ASCD BRAKE SWITCH

1. Turn ignition switch OFF.
2. Disconnect ASCD brake switch harness connector.
3. Check harness continuity between ASCD brake switch terminals 1 and 2 under the following conditions.

Condition	Continuity
When brake pedal is fully released.	Should exist.
When brake pedal is slightly depressed.	Should not exist.

If NG, adjust ASCD brake switch installation, refer to [BR-6](#), "[BRAKE PEDAL](#)", and perform step 3 again.

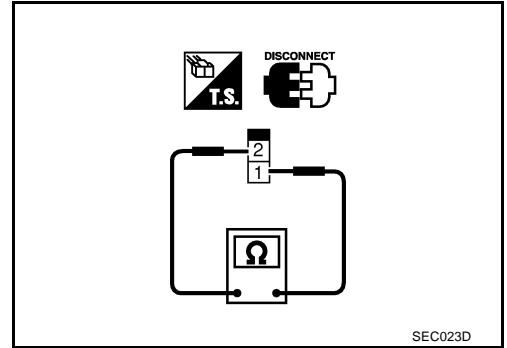

STOP LAMP SWITCH

1. Turn ignition switch OFF.
2. Disconnect stop lamp switch harness connector.
3. Check harness continuity between stop lamp switch terminals 1 and 2 under the following conditions.

Condition	Continuity
When brake pedal is fully released.	Should not exist.
When brake pedal is slightly depressed.	Should exist.

If NG, adjust stop lamp switch installation, refer to [BR-6](#), "[BRAKE PEDAL](#)", and perform step 3 again.

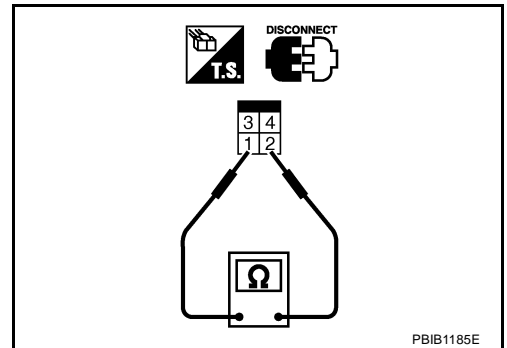

A
EC
C
D
E
F
G
H
I
J
K
L
M

ASC D INDICATOR

PFP:24814

Component Description

ABS006Z2

ASC D indicator lamp illuminates to indicate ASC D operation status. Lamp has two indicators, CRUISE and SET, and is integrated in combination meter.

CRUISE indicator illuminates when ON/OFF(MAIN) switch on ASC D steering switch is turned ON to indicated that ASC D system is ready for operation.

SET indicator illuminates when following conditions are met.

- CRUISE indicator is illuminated.
- SET switch on ASC D steering switch is turned ON while vehicle speed is within the range of ASC D setting.

SET indicator remains lit during ASC D control.

Refer to [EC-657, "AUTOMATIC SPEED CONTROL DEVICE \(ASC D\)"](#) for the ASC D function.

CONSULT-II Reference Value in Data Monitor Mode

ABS006Z3

Specification data are reference value.

MONITOR ITEM	CONDITION		SPECIFICATION
CRUISE LAMP	● Ignition switch: ON	● ON/OFF(MAIN) switch: Pressed at the 1st time → at the 2nd time	ON → OFF
SET LAMP	● ON/OFF(MAIN) switch: ON	● ASC D is operating	ON
	● When vehicle speed is between 40 km/h (25 MPH) and 144 km/h (89 MPH)	● ASC D is not operating	OFF

ASC D INDICATOR

[VQ35DE]

ABS006Z4

Wiring Diagram

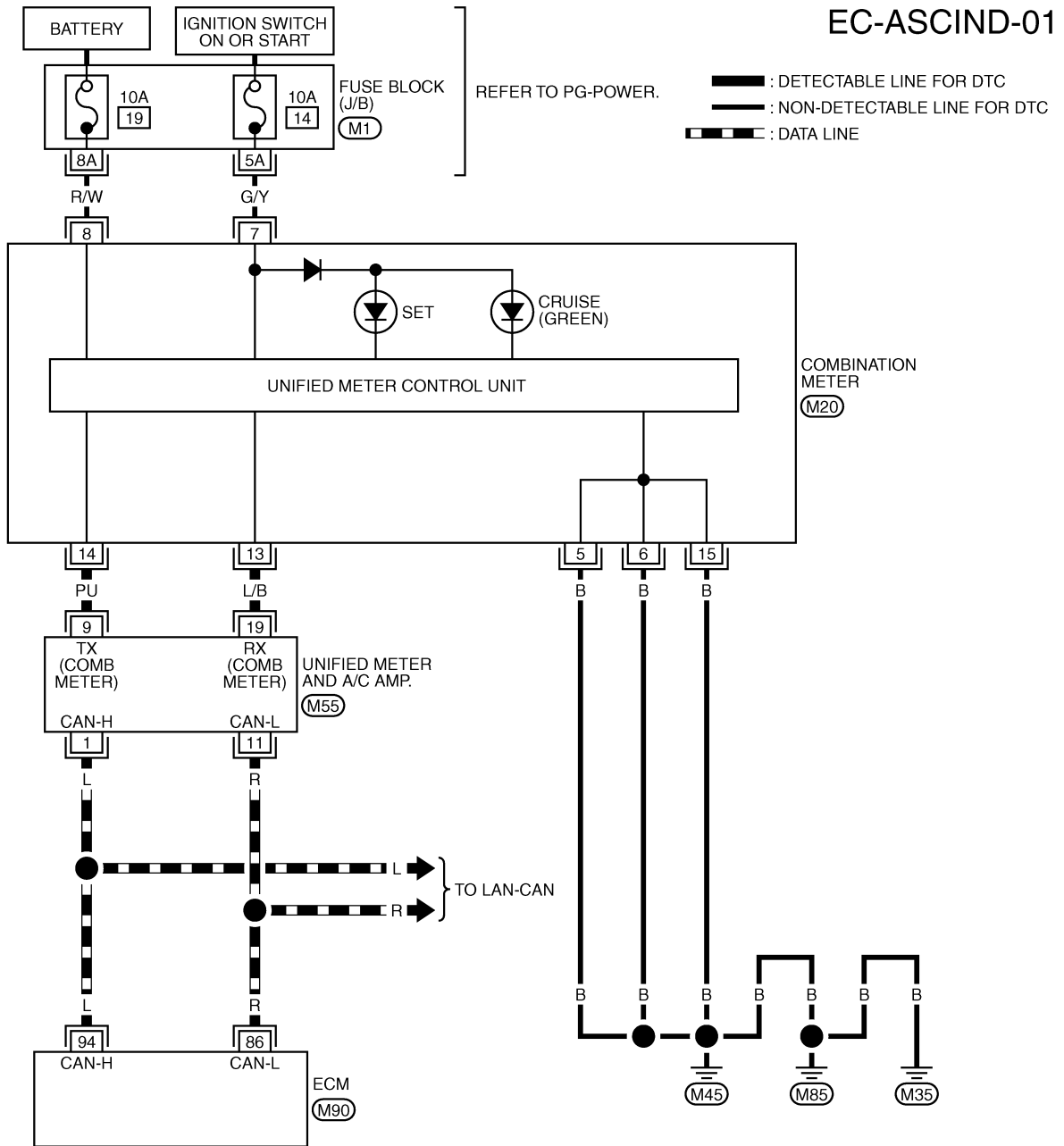

A
EC
C
D
E
F
G
H
I
J
K
L
M

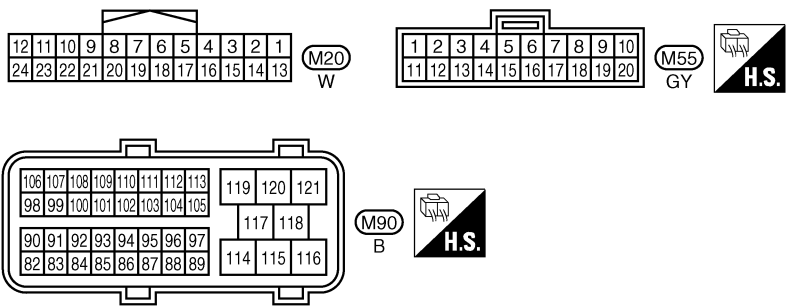

REFER TO THE FOLLOWING.
 (M1) - FUSE BLOCK-JUNCTION BOX (J/B)

TBWM0267E

Diagnostic Procedure

1. CHECK OVERALL FUNCTION

Check ASC D indicator under the following conditions.

ASC D INDICATOR	CONDITION		SPECIFICATION
CRUISE LAMP	<ul style="list-style-type: none"> ● Ignition switch: ON 	<ul style="list-style-type: none"> ● ON/OFF(MAIN) switch: pressed at the 1st time → at the 2nd time 	ON → OFF
SET LAMP	<ul style="list-style-type: none"> ● ON/OFF(MAIN) switch: ON ● When vehicle speed is between 40 km/h (25 MPH) and 144 km/h (89 MPH) 	<ul style="list-style-type: none"> ● ASC D is operating ● ASC D is not operating 	ON OFF

OK or NG

- OK >> **INSPECTION END**
- NG >> GO TO 2.

2. CHECK DTC

Check that DTC U1000 or U1001 is not displayed.

OK or NG

- OK >> GO TO 3.
- NG >> Perform trouble diagnoses for DTC U1000, U1001. Refer to [EC-142, "DTC U1000, U1001 CAN COMMUNICATION LINE"](#) .

3. CHECK DTC WITH "UNIFIED METER AND A/C AMP."

Refer to [DI-32, "SELF-DIAGNOSTIC RESULTS"](#) .

OK or NG

- OK >> GO TO 4.
- NG >> Go to [DI-22, "Communication Line Inspection"](#) .

4. CHECK INTERMITTENT INCIDENT

Refer to [EC-135, "TROUBLE DIAGNOSIS FOR INTERMITTENT INCIDENT"](#) .

>> **INSPECTION END**

SNOW MODE SWITCH

PF:25310

Description

ABS00A2B

NOTE:

If DTC U1000 or U1001 are displayed, first perform the trouble diagnosis for DTC U1000, U1001.

Refer to [EC-142, "DTC U1000, U1001 CAN COMMUNICATION LINE"](#).

The snow mode switch signal is sent to the "unified meter and A/C amp." from the snow mode switch. The "unified meter and A/C amp." then sends the signal to the ECM by CAN communication line.

The snow mode is used for driving or starting the vehicle on snowy roads or slippery areas. If the snow mode is activated, the vehicle speed will not be accelerated immediately than your original pedal in due to avoid the vehicle slip. In other words, ECM controls the rapid engine torque change by controlling the electric throttle control actuator operating speed.

CONSULT-II Reference Value in the Data Monitor Mode

ABS00A2C

MONITOR ITEM	CONDITION		SPECIFICATION
SNOW MODE SW	● Ignition switch: ON	SNOW MODE SW: ON	ON
		SNOW MODE SW: OFF	OFF

A
EC
C
D
E
F
G
H
I
J
K
L
M

SNOW MODE SWITCH

[VQ35DE]

ABS00A2D

Wiring Diagram

EC-SNOWSW-01

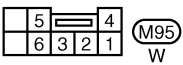
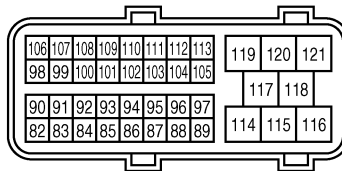
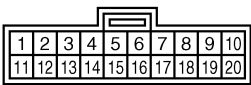
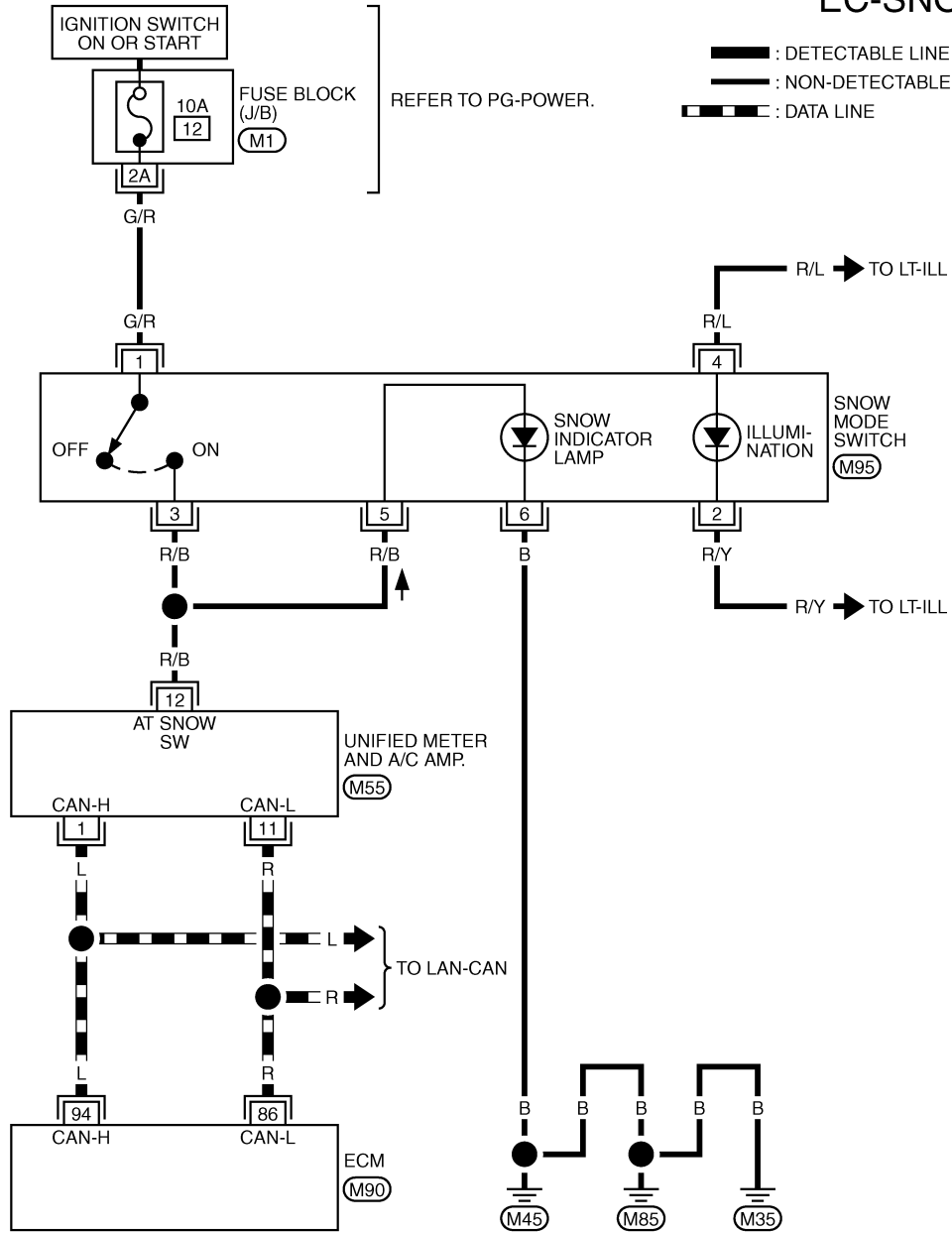

REFER TO THE FOLLOWING.

(M1) - FUSE BLOCK-JUNCTION BOX (J/B)

TBWH0217E

Diagnostic Procedure

1. CHECK SNOW MODE SWITCH OVERALL FUNCTION-I

1. Turn ignition switch ON.
2. Select "SNOW MODE SW" in "DATA MONITOR" mode with CONSULT-II.
3. Check "SNOW MODE SW" indication under the following conditions.

CONDITION	INDICATION
Snow mode switch: ON	ON
Snow mode switch: OFF	OFF

OK or NG

- OK >> GO TO 2.
 NG >> GO TO 3.

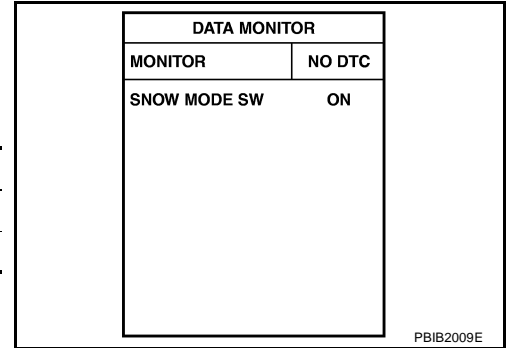

2. CHECK SNOW MODE SWITCH OVERALL FUNCTION- II

1. Start engine.
2. Check the snow mode indicator in the snow mode switch under the following condition.

CONDITION	INDICATION
Snow mode switch: ON	ON
Snow mode switch: OFF	OFF

OK or NG

- OK >> **INSPECTION END**
 NG >> GO TO 3.

3. CHECK GROUND CONNECTIONS

1. Turn ignition switch OFF.
2. Loosen and retighten ground three screws on the body. Refer to [EC-141, "Ground Inspection"](#).

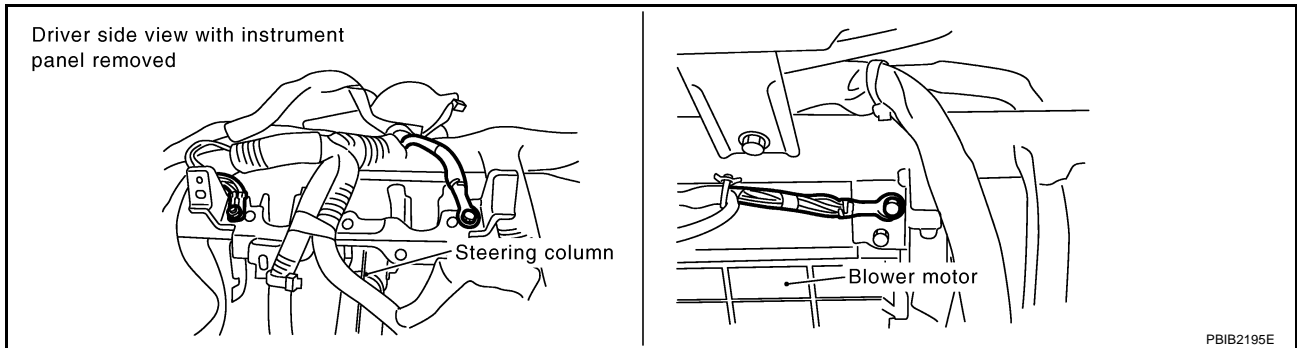

OK or NG

- OK >> GO TO 4.
 NG >> Repair or replace ground connections.

4. CHECK POWER SUPPLY CIRCUIT-I

1. Disconnect "unified meter and A/C amp." harness connector.
2. Turn ignition switch ON.
3. Check voltage between "unified meter and A/C amp." terminal 12 and ground under the following conditions with CONSULT-II or tester.

CONDITION	VOLTAGE
Snow mode switch: ON	Battery voltage
Snow mode switch: OFF	0V

OK or NG

- OK >> GO TO 8.
 NG >> GO TO 5.

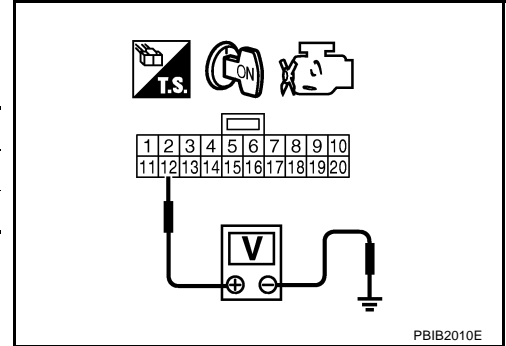

5. CHECK POWER SUPPLY CIRCUIT-II

1. Turn ignition switch OFF.
2. Disconnect snow mode switch.
3. Turn ignition switch ON.
4. Check voltage between snow mode switch terminal 1 and ground with CONSULT-II or tester.

Voltage: Battery voltage.

OK or NG

- OK >> GO TO 7.
 NG >> GO TO 6.

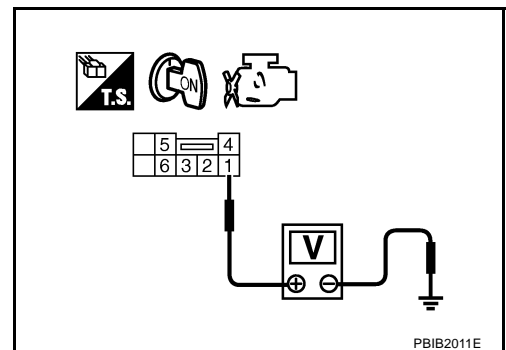

6. DETECT MALFUNCTIONING PART

Check the following.

- 10A fuse
- Fuse block (J/B) harness connector M1
- Harness for open or short between snow mode switch and fuse.

>> Repair open circuit or short to ground or short to power in harness or connectors.

7. CHECK SNOW MODE SWITCH OUT PUT SIGNAL CIRCUIT FOR OPEN AND SHORT

1. Turn ignition switch OFF.
2. Check harness continuity between snow mode switch terminal 3 and "unified meter and A/C amp." terminal 12. Refer to Wiring Diagram.

Continuity should exist.

3. Also check harness for short to ground and short to power.

OK or NG

- OK >> GO TO 8.
 NG >> Repair open circuit or short to ground or short to power in harness or connectors.

8. CHECK SNOW MODE INDICATOR LAMP INPUT SIGNAL CIRCUIT FOR OPEN AND SHORT

1. Turn ignition switch OFF.
2. Disconnect snow mode switch harness connector.
3. Check harness continuity between snow mode switch terminal 5 and “unified meter and A/C amp.” terminal 12. Refer to Wiring Diagram.

Continuity should exist.

4. Also check harness for short to ground and short to power.

OK or NG

OK >> GO TO 9.

NG >> Repair open circuit or short to ground or short to power in harness or connectors.

9. CHECK SNOW MODE INDICATOR LAMP GROUND CIRCUIT FOR OPEN AND SHORT

1. Check harness continuity between snow mode switch terminal 6 and ground. Refer to Wiring Diagram.

Continuity should exist.

2. Also check harness for short to power.

OK or NG

OK >> GO TO 10.

NG >> Repair open circuit or short to power in harness or connectors.

10. CHECK SNOW MODE INDICATOR LAMP

Check harness continuity between snow mode switch terminals 5 and 6 under the following conditions.

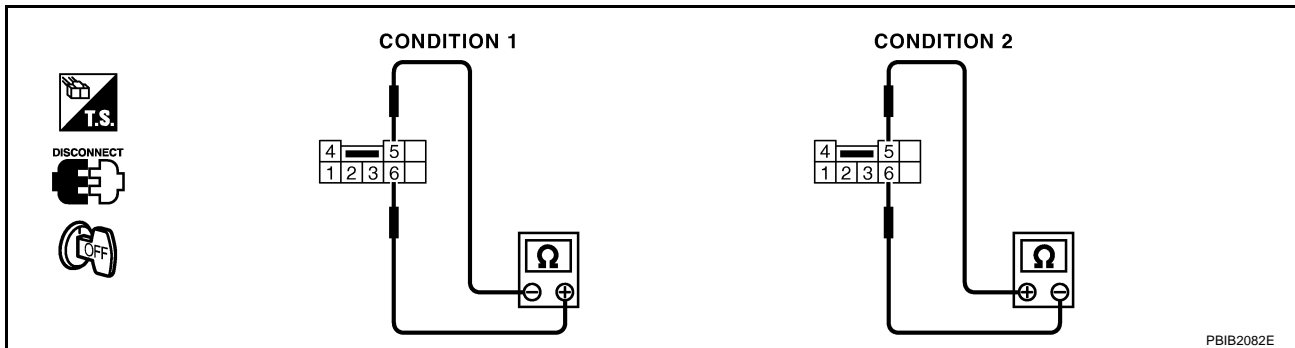

Condition	Continuity
1	Should exist.
2	Should not exist.

OK or NG

OK >> GO TO 11.

NG >> Replace snow mode switch.

11. CHECK SNOW MODE SWITCH

Refer to [EC-640, "Component Inspection"](#).

OK or NG

OK >> GO TO 12.

NG >> Replace snow mode switch.

12. CHECK “UNIFIED METER AND A/C AMP.”

Refer to [DI-28, "UNIFIED METER AND A/C AMP"](#) .

OK or NG

OK >> GO TO 13.

NG >> Replace “unified meter and A/C amp.”.

13. CHECK INTERMITTENT INCIDENT

Refer to [EC-135, "TROUBLE DIAGNOSIS FOR INTERMITTENT INCIDENT"](#) .

>> INSPECTION END

Component Inspection SNOW MODE SWITCH

ABS00A2P

1. Check snow mode switch continuity between terminals 1 and 3 under the following condition.

CONDITION	CONTINUITY
Snow mode switch is ON	Should exist
Snow mode switch is OFF	Should not exist

2. If NG, replace snow mode switch.

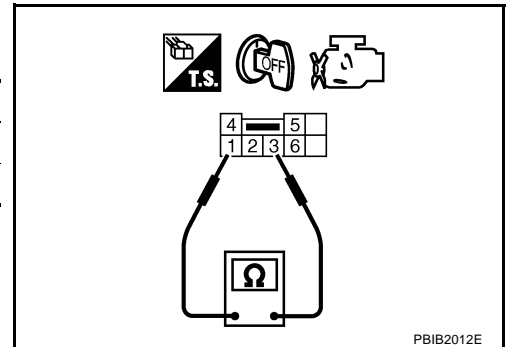

MIL AND DATA LINK CONNECTOR

[VQ35DE]

MIL AND DATA LINK CONNECTOR

PFP:24814

Wiring Diagram

ABS006Z6

EC-MIL/DL-01

A
EC
C
D
E
F
G
H
I
J
K
L
M

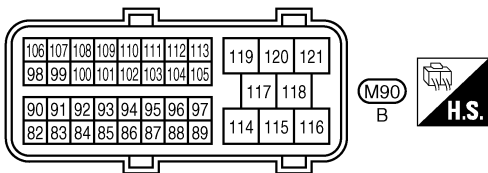
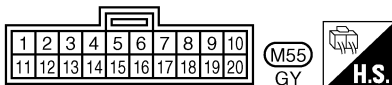
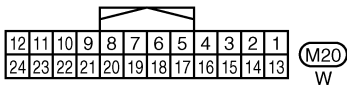
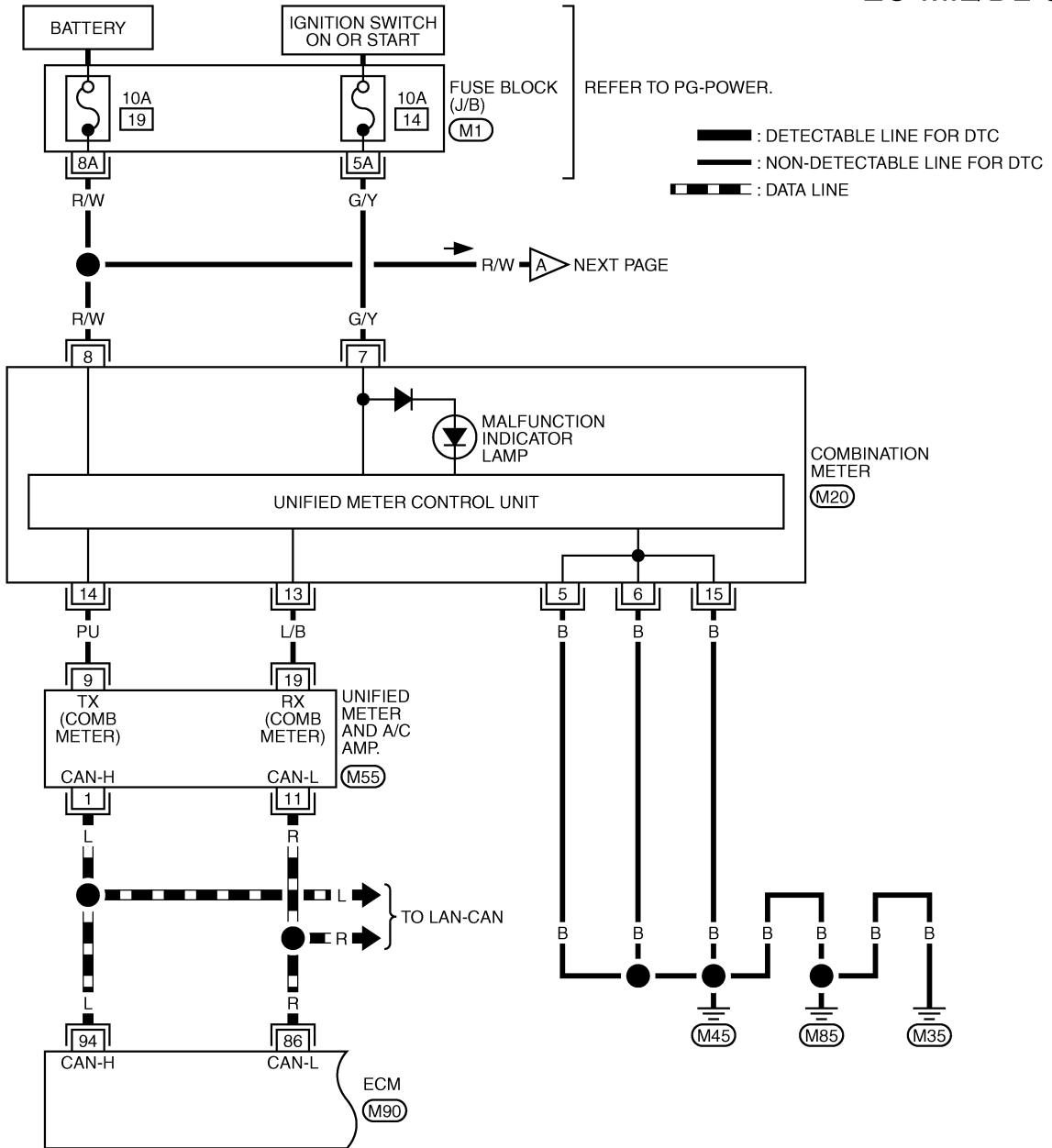

REFER TO THE FOLLOWING.

(M1) - FUSE BLOCK-JUNCTION BOX (J/B)

TBWM0268E

MIL AND DATA LINK CONNECTOR

[VQ35DE]

EC-MIL/DL-02

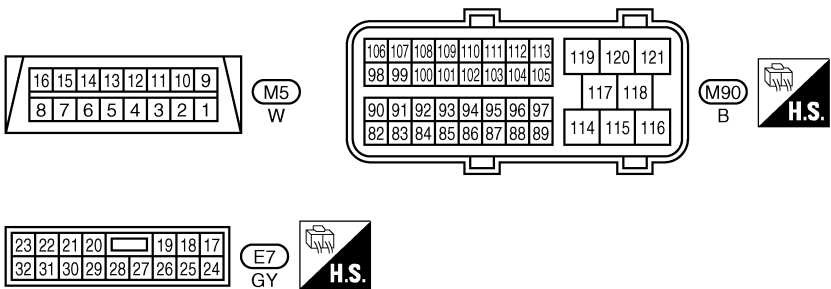
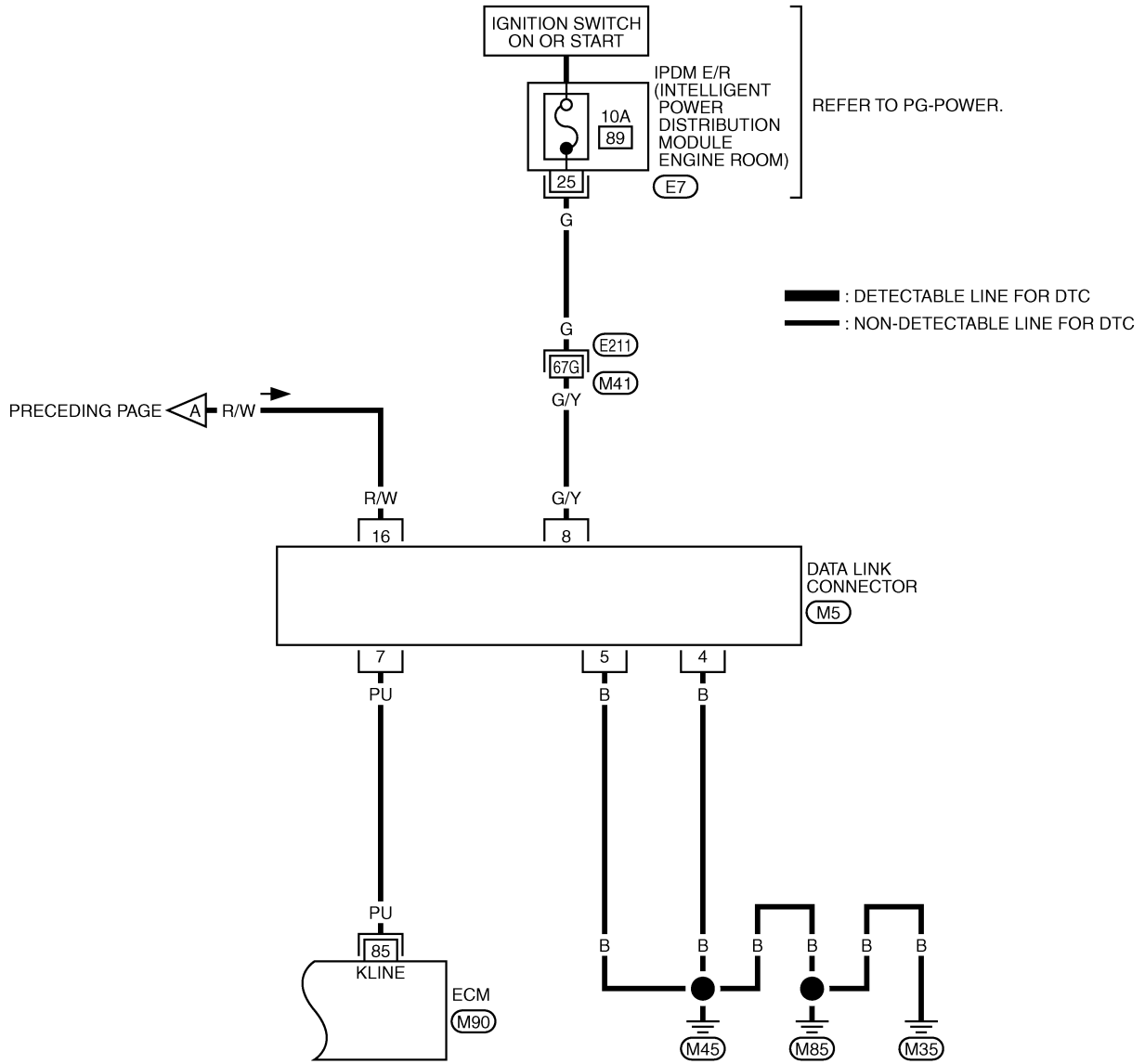

REFER TO THE FOLLOWING.

E211 -SUPER MULTIPLE JUNCTION (SMJ)

TBWM0269E

EVAPORATIVE EMISSION SYSTEM

PFP:14950

Description SYSTEM DESCRIPTION

ABS006Z7

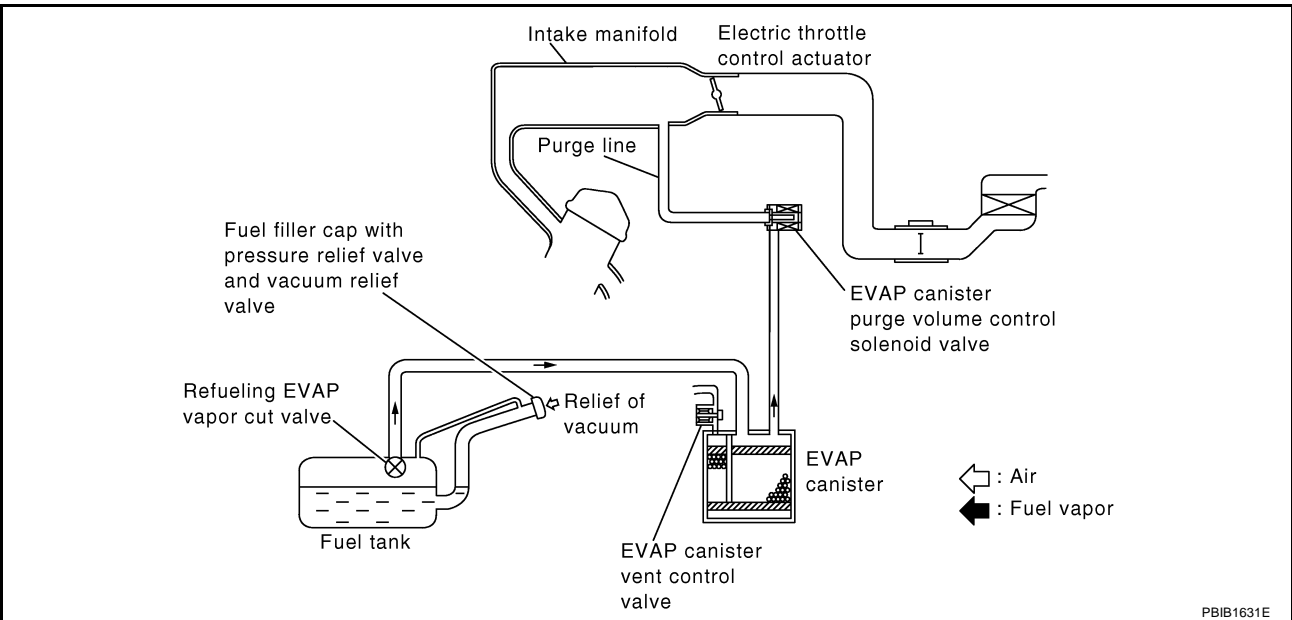

The evaporative emission system is used to reduce hydrocarbons emitted into the atmosphere from the fuel system. This reduction of hydrocarbons is accomplished by activated charcoals in the EVAP canister. The fuel vapor in the sealed fuel tank is led into the EVAP canister which contains activated carbon and the vapor is stored there when the engine is not operating or when refueling to the fuel tank. The vapor in the EVAP canister is purged by the air through the purge line to the intake manifold when the engine is operating. EVAP canister purge volume control solenoid valve is controlled by ECM. When the engine operates, the flow rate of vapor controlled by EVAP canister purge volume control solenoid valve is proportionally regulated as the air flow increases. EVAP canister purge volume control solenoid valve also shuts off the vapor purge line during decelerating and idling.

EVAPORATIVE EMISSION SYSTEM

[VQ35DE]

EVAPORATIVE EMISSION LINE DRAWING

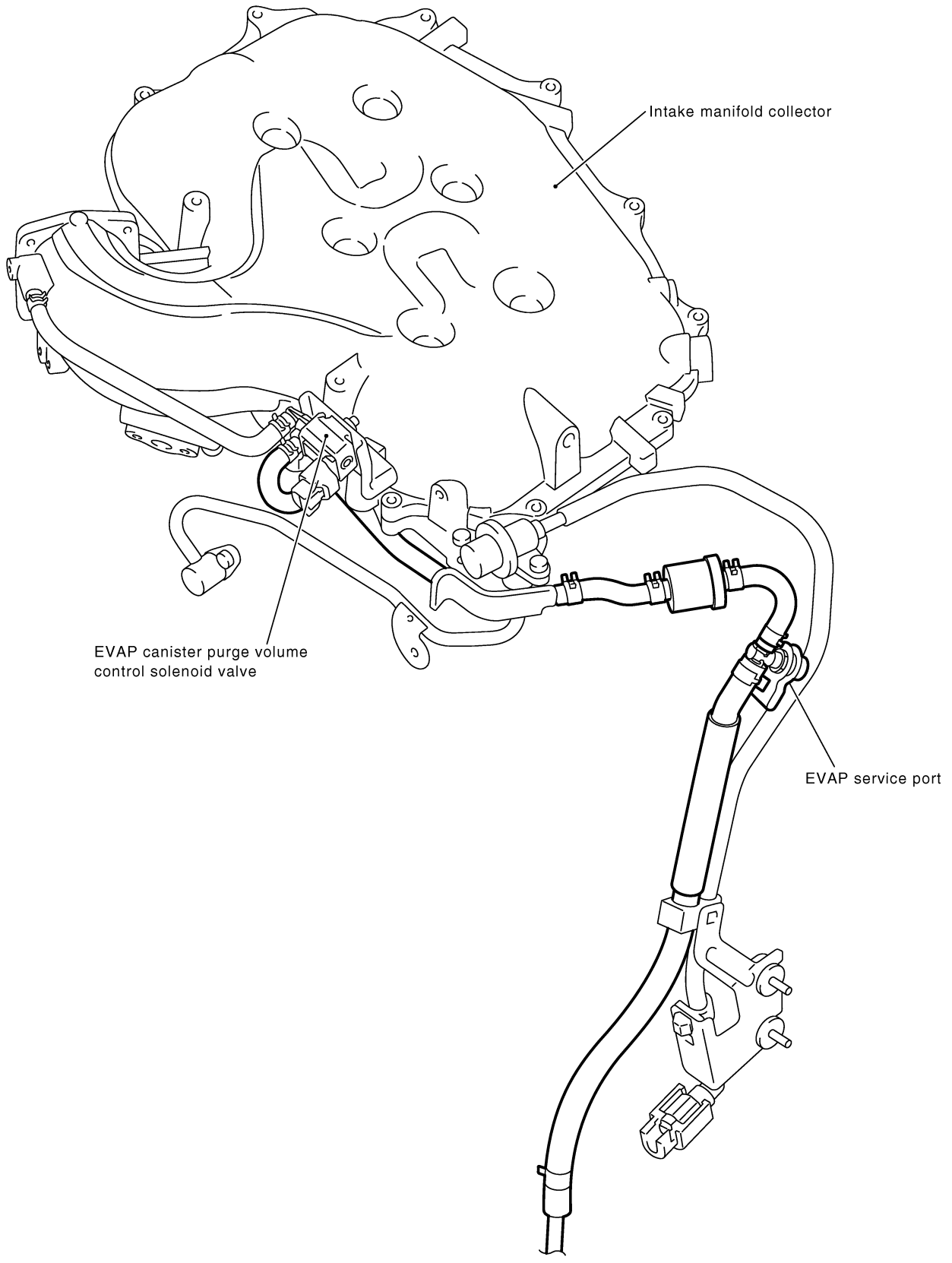

NOTE: Do not use soapy water or any type of solvent while installing vacuum hose or purge hoses.

↑
A (From next page)

PBIB2008E

A

EC

C

D

E

F

G

H

I

J

K

L

M

With undercover removed

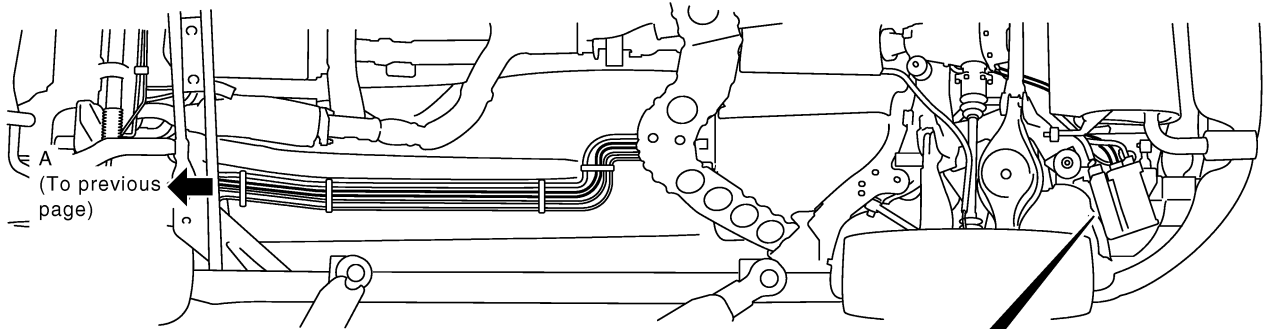

A
(To previous page)

View from under the vehicle
With undercover removed

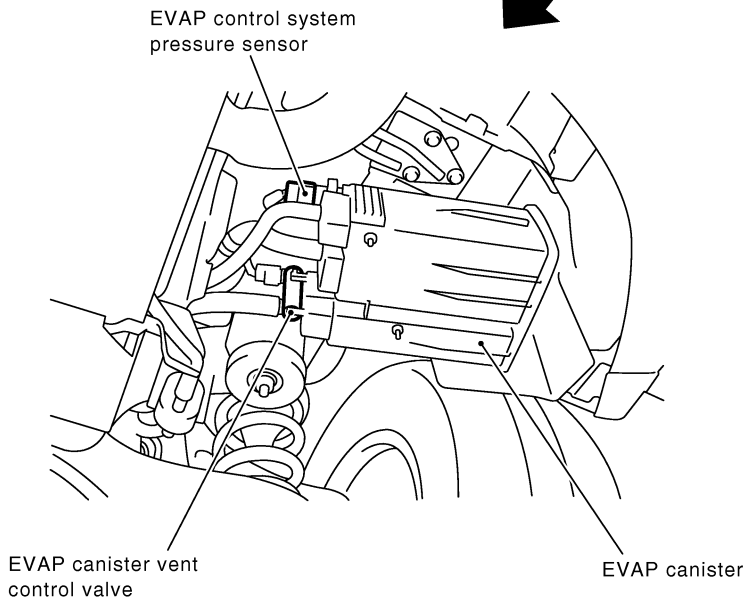

PBIB2295E

Component Inspection EVAP CANISTER

Check EVAP canister as follows:

1. Block port **B** .
2. Blow air into port **A** and check that it flows freely out of port **C** .
3. Release blocked port **B** .
4. Apply vacuum pressure to port **B** and check that vacuum pressure exists at the ports **A** and **C** .
5. Block port **A** and **B** .
6. Apply pressure to port **C** and check that there is no leakage.

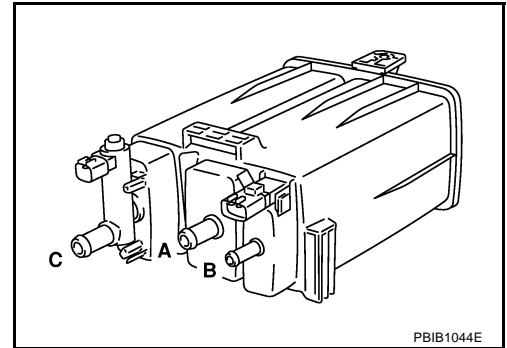

FUEL TANK VACUUM RELIEF VALVE (BUILT INTO FUEL FULLER CAP)

1. Wipe clean valve housing.

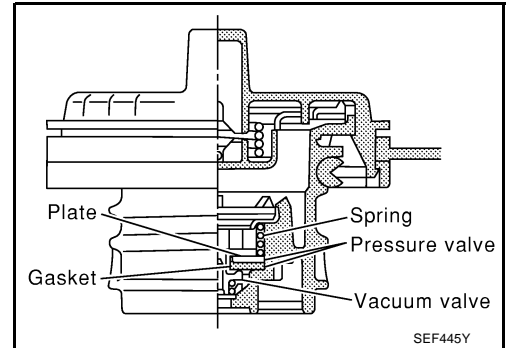

2. Check valve opening pressure and vacuum.

Pressure: 15.3 - 20.0 kPa (0.156 - 0.204 kg/cm² , 2.22 - 2.90 psi)

Vacuum: -6.0 to -3.3 kPa (-0.061 to -0.034 kg/cm² , -0.87 to -0.48 psi)

3. If out of specification, replace fuel filler cap as an assembly.

CAUTION:

Use only a genuine fuel filler cap as a replacement. If an incorrect fuel filler cap is used, the MIL may come on.

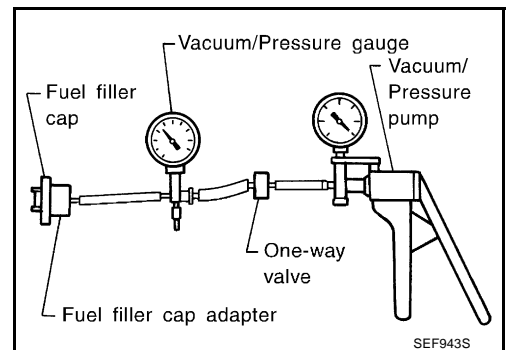

EVAP CANISTER PURGE VOLUME CONTROL SOLENOID VALVE

Refer to [EC-340](#) .

FUEL TANK TEMPERATURE SENSOR

Refer to [EC-277](#) .

EVAP CANISTER VENT CONTROL VALVE

Refer to [EC-347](#) .

EVAP CONTROL SYSTEM PRESSURE SENSOR

Refer to [EC-357](#) .

EVAP SERVICE PORT

Positive pressure is delivered to the EVAP system through the EVAP service port. If fuel vapor leakage in the EVAP system occurs, use a leak detector to locate the leak.

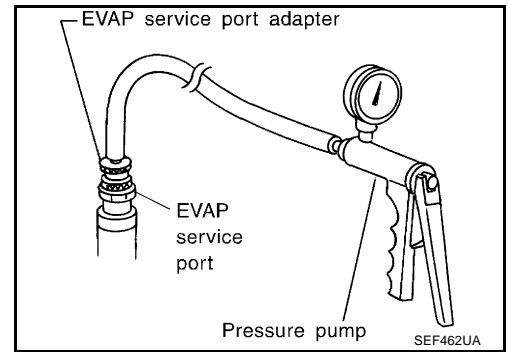

ABS006Z9

Removal and Installation EVAP CANISTER

Tighten EVAP canister as shown in the figure.

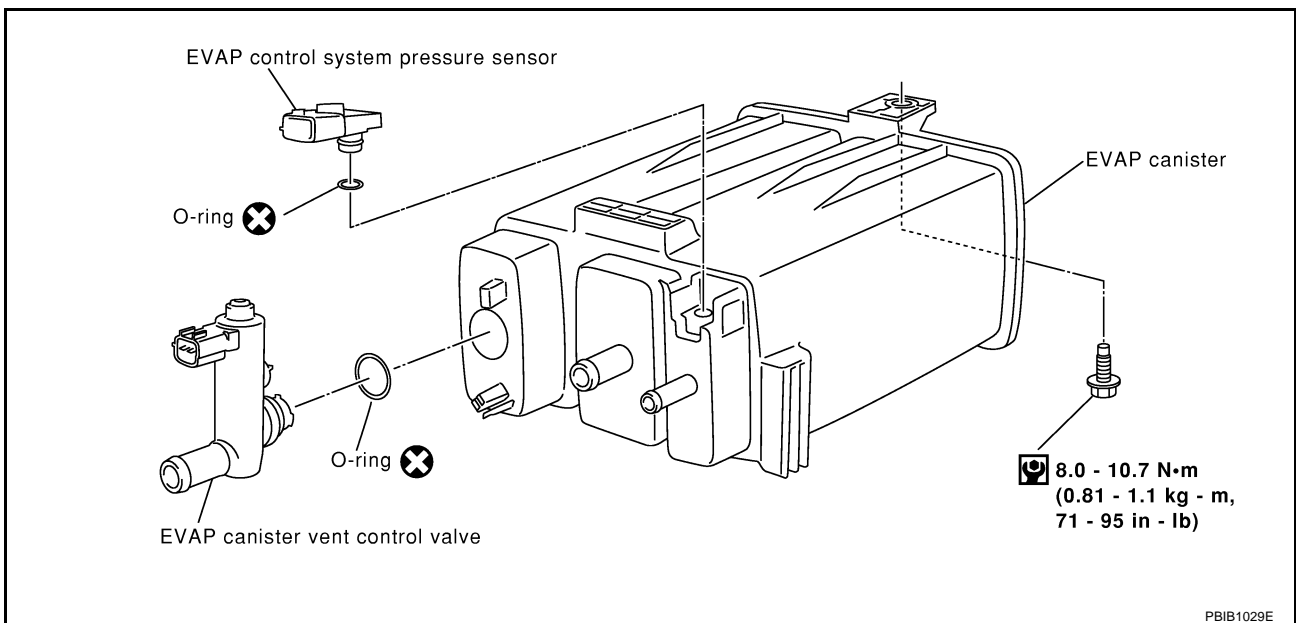

EVAP CANISTER VENT CONTROL VALVE

1. Turn EVAP canister vent control valve counterclockwise.
2. Remove the EVAP canister vent control valve.

Do not reuse the O-ring, replace it with a new one.

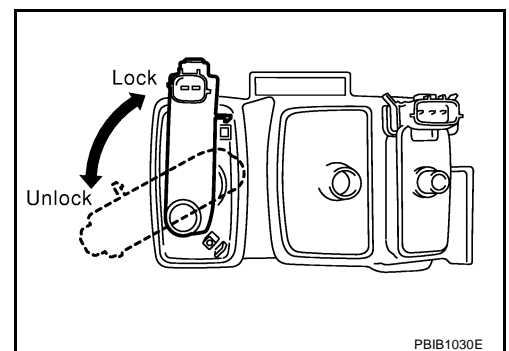

How to Detect Fuel Vapor Leakage

CAUTION:

- Never use compressed air or a high pressure pump.
- Do not exceed 4.12 kPa (0.042 kg/cm², 0.6 psi) of pressure in EVAP system.

NOTE:

- Do not start engine.
- Improper installation of EVAP service port adapter to the EVAP service port may cause a leak.

ABS006ZA

WITH CONSULT-II

1. Attach the EVAP service port adapter securely to the EVAP service port.
2. Also attach the pressure pump and hose to the EVAP service port adapter.
3. Turn ignition switch ON.
4. Select the "EVAP SYSTEM CLOSE" of "WORK SUPPORT MODE" with CONSULT-II.
5. Touch "START". A bar graph (Pressure indicating display) will appear on the screen.

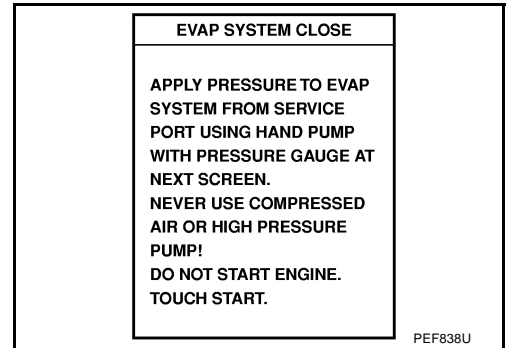

6. Apply positive pressure to the EVAP system until the pressure indicator reaches the middle of the bar graph.
7. Remove EVAP service port adapter and hose with pressure pump.

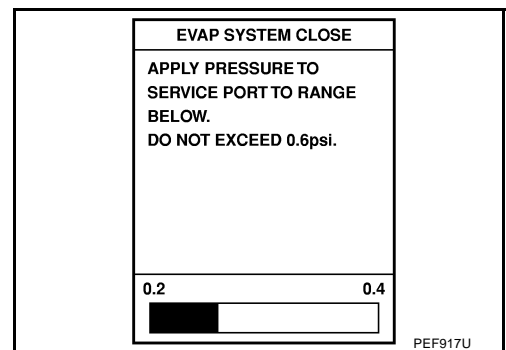

8. Locate the leak using a leak detector. Refer to [EC-644, "EVAPORATIVE EMISSION LINE DRAWING"](#).

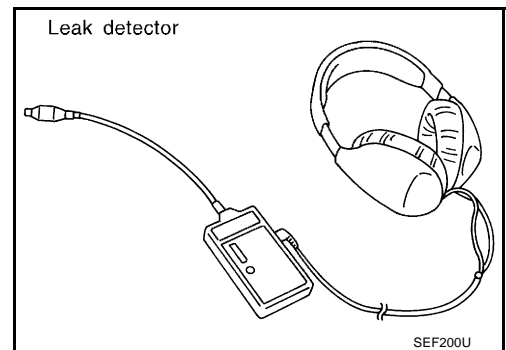

WITHOUT CONSULT-II

1. Attach the EVAP service port adapter securely to the EVAP service port.
2. Also attach the pressure pump with pressure gauge to the EVAP service port adapter.

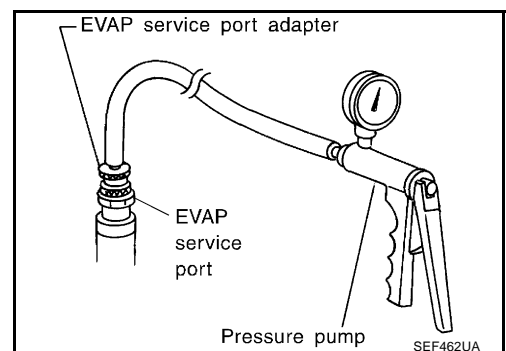

EVAPORATIVE EMISSION SYSTEM

[VQ35DE]

3. Apply battery voltage between the terminals of EVAP canister vent control valve to make a closed EVAP system.

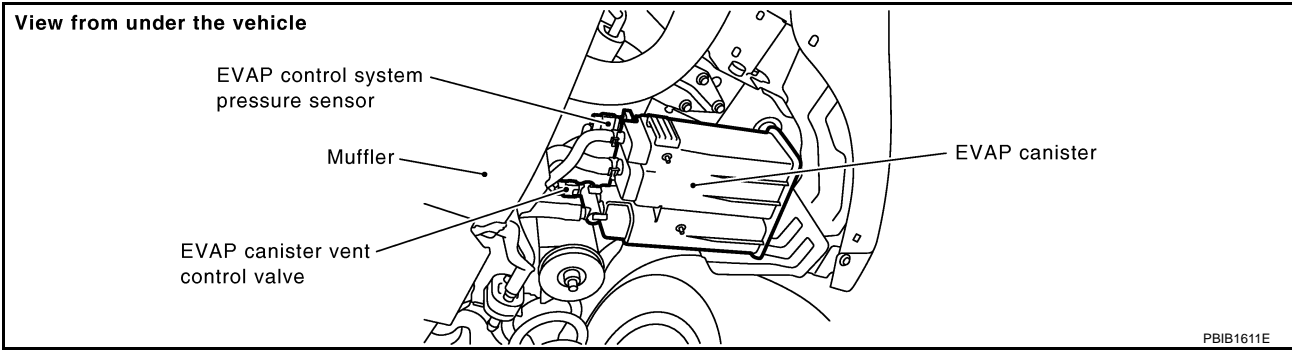

4. To locate the leak, deliver positive pressure to the EVAP system until pressure gauge points reach 1.38 to 2.76 kPa (0.014 to 0.028 kg/cm² , 0.2 to 0.4 psi).
5. Remove EVAP service port adapter and hose with pressure pump.
6. Locate the leak using a leak detector. Refer to [EC-644, "EVAPORATIVE EMISSION LINE DRAWING"](#) .

A

EC

C

D

E

F

G

H

I

J

K

L

M

ON BOARD REFUELING VAPOR RECOVERY (ORVR)

PFP:00032

System Description

ABS006ZB

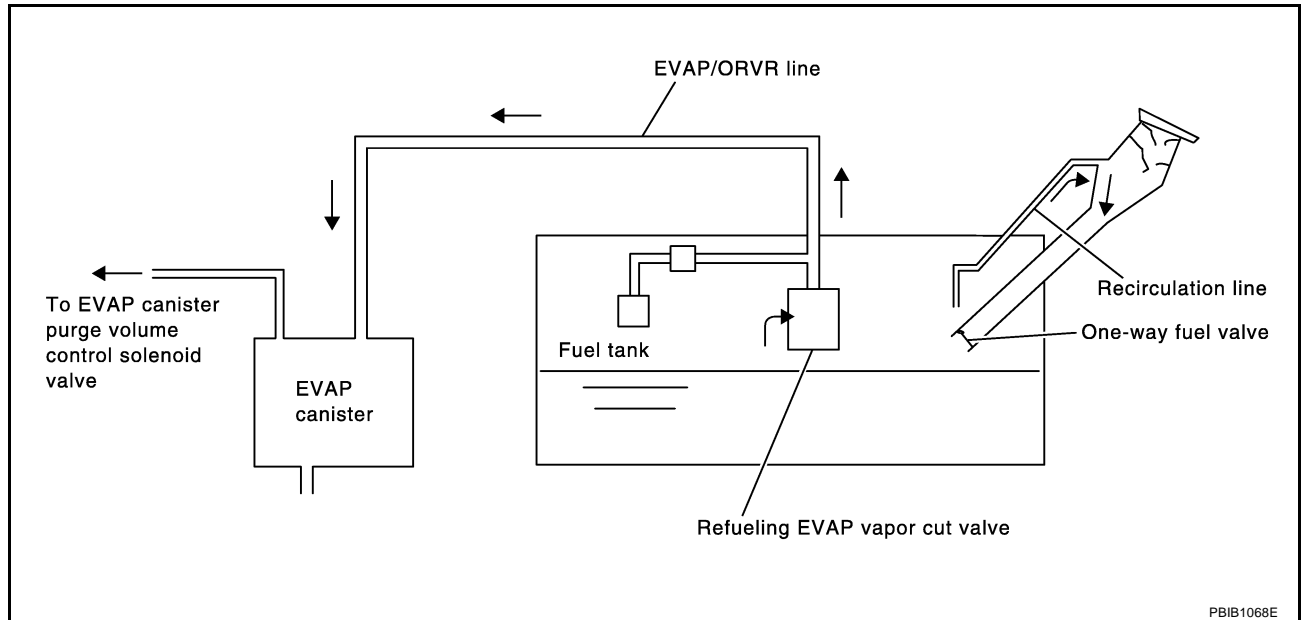

PBIB1068E

From the beginning of refueling, the air and vapor inside the fuel tank go through refueling EVAP vapor cut valve and EVAP/ORVR line to the EVAP canister. The vapor is absorbed by the EVAP canister and the air is released to the atmosphere.

When the refueling has reached the full level of the fuel tank, the refueling EVAP vapor cut valve is closed and refueling is stopped because of auto shut-off. The vapor which was absorbed by the EVAP canister is purged during driving.

WARNING:

When conducting inspections below, be sure to observe the following:

- Put a "CAUTION: INFLAMMABLE" sign in workshop.
- Do not smoke while servicing fuel system. Keep open flames and sparks away from work area.
- Be sure to furnish the workshop with a CO₂ fire extinguisher.

CAUTION:

- Before removing fuel line parts, carry out the following procedures:
 - Put drained fuel in an explosion-proof container and put lid on securely.
 - Release fuel pressure from fuel line. Refer to Fuel Pressure Release, [EC-51](#) .
 - Disconnect battery ground cable.
- Always replace O-ring when the fuel gauge retainer is removed.
- Do not kink or twist hose and tube when they are installed.
- Do not tighten hose and clamps excessively to avoid damaging hoses.
- After installation, run engine and check for fuel leaks at connection.
- Do not attempt to top off the fuel tank after the fuel pump nozzle shuts off automatically. Continued refueling may cause fuel overflow, resulting in fuel spray and possibly a fire.

Diagnostic Procedure

SYMPTOM: FUEL ODOR FROM EVAP CANISTER IS STRONG

1. CHECK EVAP CANISTER

1. Remove EVAP canister with EVAP canister vent control valve and EVAP control system pressure sensor attached.
2. Weigh the EVAP canister with EVAP canister vent control valve and EVAP control system pressure sensor attached.
The weight should be less than 2.1 kg (4.6 lb).

OK or NG

- OK >> GO TO 2.
NG >> GO TO 3.

2. CHECK IF EVAP CANISTER SATURATED WITH WATER

Does water drain from the EVAP canister?

Yes or No

- Yes >> GO TO 3.
No >> GO TO 5.

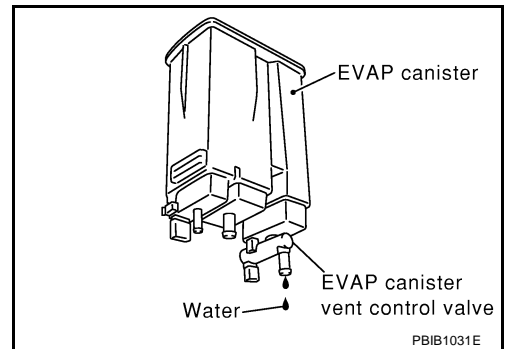

3. REPLACE EVAP CANISTER

Replace EVAP canister with a new one.

>> GO TO 4.

4. DETECT MALFUNCTIONING PART

Check the EVAP hose between EVAP canister and vehicle frame for clogging or poor connection.

>> Repair or replace EVAP hose.

5. CHECK REFUELING EVAP VAPOR CUT VALVE

Refer to [EC-653, "Component Inspection"](#) .

OK or NG

- OK >> **INSPECTION END**
NG >> Replace refueling EVAP vapor cut valve with fuel tank.

SYMPTOM: CANNOT REFUEL/FUEL ODOR FROM THE FUEL FILLER OPENING IS STRONG WHILE REFUELING

1. CHECK EVAP CANISTER

1. Remove EVAP canister with EVAP canister vent control valve and EVAP control system pressure sensor attached.
2. Weigh the EVAP canister with EVAP canister vent control valve and EVAP control system pressure sensor attached.
The weight should be less than 2.1 kg (4.6 lb).

OK or NG

- OK >> GO TO 2.
NG >> GO TO 3.

2. CHECK IF EVAP CANISTER SATURATED WITH WATER

Does water drain from the EVAP canister?

Yes or No

- Yes >> GO TO 3.
No >> GO TO 5.

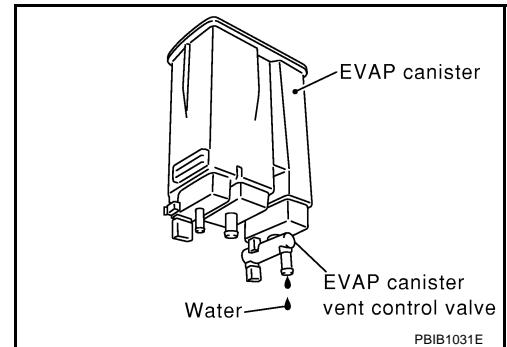

3. REPLACE EVAP CANISTER

Replace EVAP canister with a new one.

>> GO TO 4.

4. DETECT MALFUNCTIONING PART

Check the EVAP hose between EVAP canister and vehicle frame for clogging or poor connection.

>> Repair or replace EVAP hose.

5. CHECK VENT HOSES AND VENT TUBES

Check hoses and tubes between EVAP canister and refueling control valve for clogging, kink, looseness and improper connection.

OK or NG

- OK >> GO TO 6.
NG >> Repair or replace hoses and tubes.

6. CHECK FILLER NECK TUBE

Check recirculation line for clogging, dents and cracks.

OK or NG

- OK >> GO TO 7.
NG >> Replace filler neck tube.

7. CHECK REFUELING EVAP VAPOR CUT VALVE

Refer to [EC-653, "Component Inspection"](#) .

OK or NG

- OK >> GO TO 8.
- NG >> Replace refueling EVAP vapor cut valve with fuel tank.

8. CHECK FUEL FILLER TUBE

Check filler neck tube and hose connected to the fuel tank for clogging, dents and cracks.

OK or NG

- OK >> GO TO 9.
- NG >> Replace fuel filler tube.

9. CHECK ONE-WAY FUEL VALVE-I

Check one-way valve for clogging.

OK or NG

- OK >> GO TO 10.
- NG >> Repair or replace one-way fuel valve with fuel tank.

10. CHECK ONE-WAY FUEL VALVE-II

1. Make sure that fuel is drained from the tank.
2. Remove fuel filler tube and hose.
3. Check one-way fuel valve for operation as follows.
When a stick is inserted, the valve should open, when removing stick it should close.

Do not drop any material into the tank.

OK or NG

- OK >> **INSPECTION END**
- NG >> Replace fuel filler tube or replace one-way fuel valve with fuel tank.

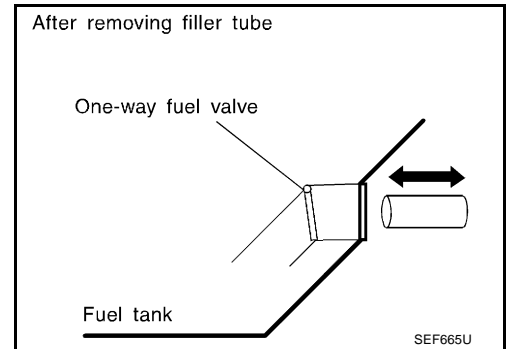

**Component Inspection
REFUELING EVAP VAPOR CUT VALVE**

Ⓟ **With CONSULT-II**

1. Remove fuel tank. Refer to [FL-10, "FUEL TANK"](#) .
2. Drain fuel from the tank as follows:
 - a. Remove fuel feed hose located on the fuel gauge retainer.
 - b. Connect a spare fuel hose, one side to fuel gauge retainer where the hose was removed and the other side to a fuel container.
 - c. Drain fuel using "FUEL PUMP RELAY" in "ACTIVE TEST" mode with CONSULT-II.
3. Check refueling EVAP vapor cut valve for being stuck to close as follows.
Blow air into the refueling EVAP vapor cut valve (from the end of EVAP/ORVR line hose), and check that the air flows freely into the tank.
4. Check refueling EVAP vapor cut valve for being stuck to open as follows.
 - a. Connect vacuum pump to hose end.
 - b. Remove fuel gauge retainer with fuel gauge unit.
Always replace O-ring with new one.
 - c. Put fuel tank upside down.

ON BOARD REFUELING VAPOR RECOVERY (ORVR)

[VQ35DE]

- d. Apply vacuum pressure to hose end [-13.3 kPa (-100 mmHg, -3.94 inHg)] with fuel gauge retainer remaining open and check that the pressure is applicable.

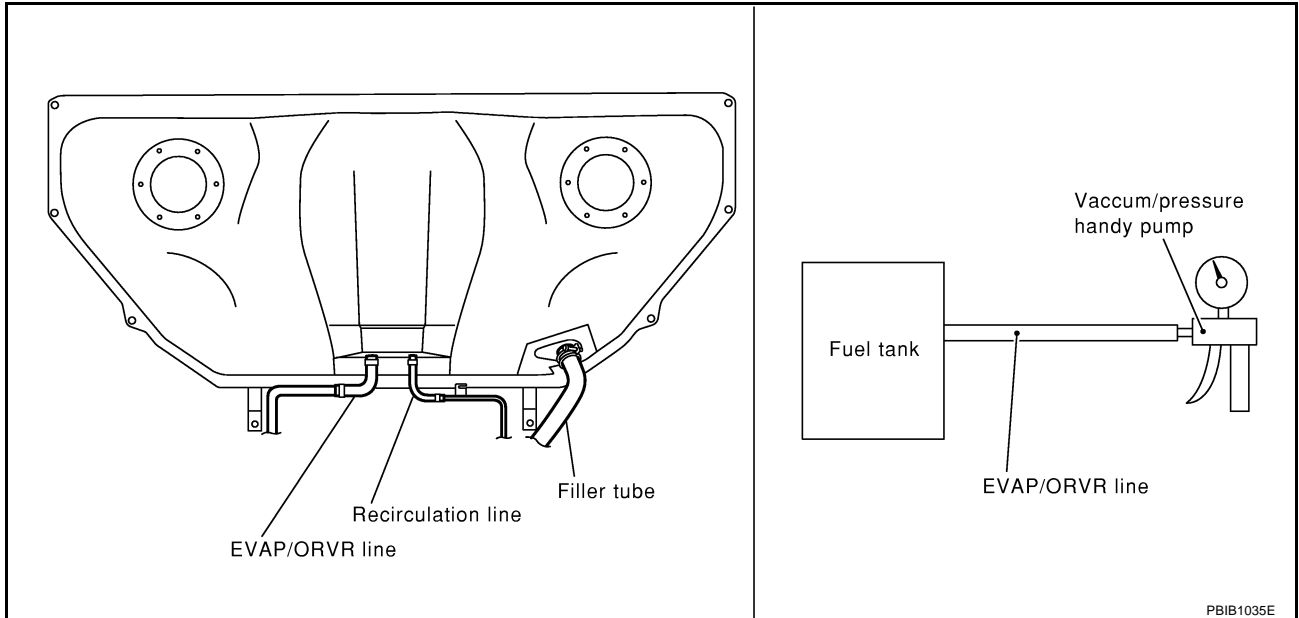

⊗ Without CONSULT-II

1. Remove fuel tank. Refer to [FL-10, "FUEL TANK"](#).
2. Drain fuel from the tank as follows:
 - a. Remove fuel gauge retainer.
 - b. Drain fuel from the tank using a handy pump into a fuel container.
3. Check refueling EVAP vapor cut valve for being stuck to close as follows. Blow air into the refueling EVAP vapor cut valve (from the end of EVAP/ORVR line hose), and check that the air flows freely into the tank.
4. Check refueling EVAP vapor cut valve for being stuck to open as follows.
 - a. Connect vacuum pump to hose end.
 - b. Remove fuel gauge retainer with fuel gauge unit.
Always replace O-ring with new one.
 - c. Put fuel tank upside down.
- d. Apply vacuum pressure to hose end [-13.3 kPa (-100 mmHg, -3.94 inHg)] with fuel gauge retainer remaining open and check that the pressure is applicable.

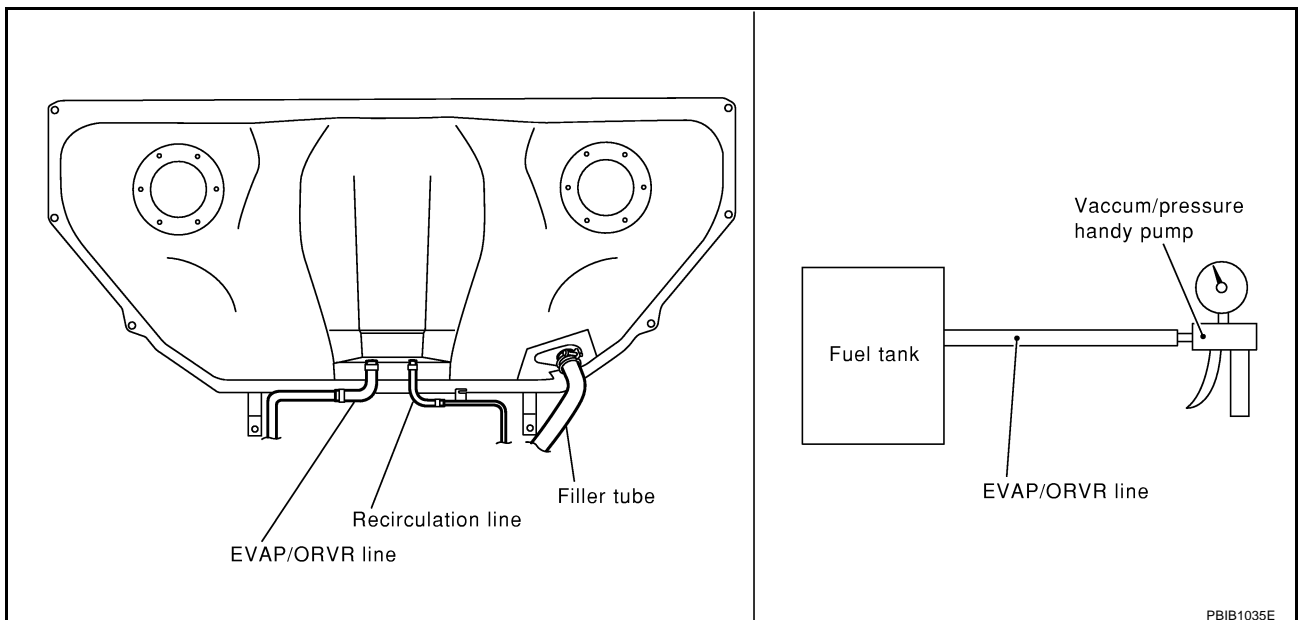

POSITIVE CRANKCASE VENTILATION

PFP:11810

Description
SYSTEM DESCRIPTION

ABS006ZE

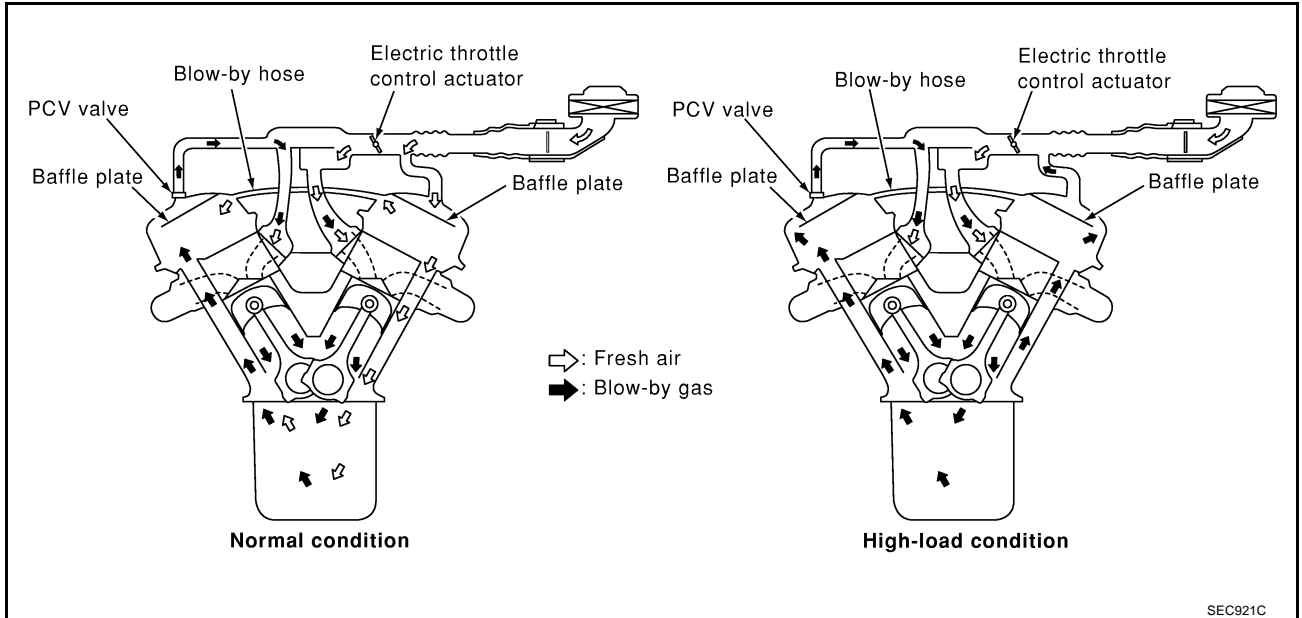

This system returns blow-by gas to the intake manifold.

The positive crankcase ventilation (PCV) valve is provided to conduct crankcase blow-by gas to the intake manifold. During partial throttle operation of the engine, the intake manifold sucks the blow-by gas through the PCV valve. Normally, the capacity of the valve is sufficient to handle any blow-by and a small amount of ventilating air. The ventilating air is then drawn from the air inlet tubes into the crankcase. In this process the air passes through the hose connecting air inlet tubes to rocker cover. Under full-throttle condition, the manifold vacuum is insufficient to draw the blow-by flow through the valve. The flow goes through the hose connection in the reverse direction.

On vehicles with an excessively high blow-by, the valve does not meet the requirement. This is because some of the flow will go through the hose connection to the air inlet tubes under all conditions.

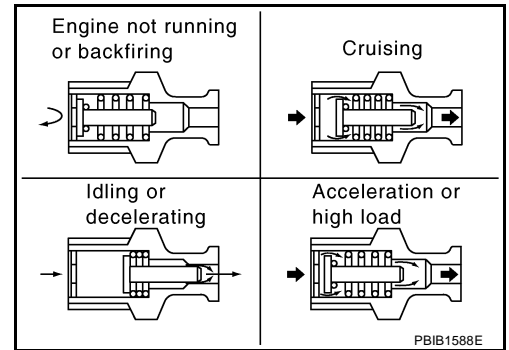

Component Inspection
PCV (POSITIVE CRANKCASE VENTILATION) VALVE

ABS006ZF

With engine running at idle, remove PCV valve from rocker cover. A properly working valve makes a hissing noise as air passes through it. A strong vacuum should be felt immediately when a finger is placed over valve inlet.

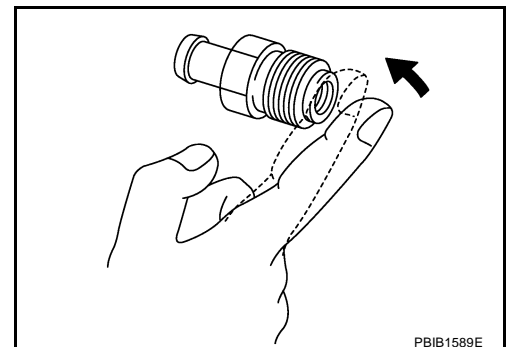

PCV VALVE VENTILATION HOSE

1. Check hoses and hose connections for leaks.
2. Disconnect all hoses and clean with compressed air. If any hose cannot be freed of obstructions, replace.

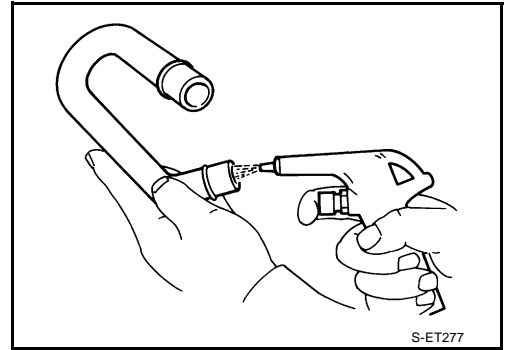

AUTOMATIC SPEED CONTROL DEVICE (ASCD)

PFP:18930

**System Description
INPUT/OUTPUT SIGNAL CHART**

ABS006ZG

Sensor	Input signal to ECM	ECM function	Actuator
ASCD brake switch	Brake pedal operation	ASCD vehicle speed control	Electric throttle control actuator
Stop lamp switch	Brake pedal operation		
ASCD steering switch	ASCD steering switch operation		
Park/Neutral position (PNP) switch	Gear position		
Unified meter and A/C amp.*	Vehicle speed		
TCM*	Powertrain revolution		

*: This signal is sent to the ECM through CAN communication line.

BASIC ASCD SYSTEM

Refer to Owner's Manual for ASCD operating instructions.

Automatic Speed Control Device (ASCD) allows a driver to keep vehicle at predetermined constant speed without depressing accelerator pedal. Driver can set vehicle speed in advance between approximately 40 km/h (25 MPH) and 144 km/h (89 MPH).

ECM controls throttle angle of electric throttle control actuator to regulate engine speed.

Operation status of ASCD is indicated by CRUISE indicator and SET indicator in combination meter. If any malfunction occurs in ASCD system, it automatically deactivates control.

SET OPERATION

Press ON/OFF(MAIN) switch. (The CRUISE indicator in combination meter illuminates.)

When vehicle speed reaches a desired speed between approximately 40 km/h (25 MPH) and 144 km/h (89 MPH), press COAST/SET switch. (Then SET indicator in combination meter illuminates.)

ACCEL OPERATION

If the ACCEL/RESUME switch is pressed during cruise control driving, increase the vehicle speed until the switch is released or vehicle speed reaches maximum speed controlled by the system.

And then ASCD will keep the new set speed.

CANCEL OPERATION

When any of following conditions exist, cruise operation will be canceled.

- CANCEL switch is pressed
- More than 2 switches at ASCD steering switch are pressed at the same time (Set speed will be cleared)
- Brake pedal is depressed
- Selector lever is changed to N, P, R position
- Vehicle speed decreased to 13 km/h (8 MPH) lower than the set speed
- VDC/TCS system is operated

When the ECM detects any of the following conditions, the ECM will cancel the cruise operation and inform the driver by blinking indicator lamp.

- Engine coolant temperature is slightly higher than the normal operating temperature, CRUISE lamp may blink slowly.
When the engine coolant temperature decreases to the normal operating temperature, CRUISE lamp will stop blinking and the cruise operation will be able to work by depressing COAST/SET switch or ACCEL/RESUME switch.
- Malfunction for some self-diagnoses regarding ASCD control: SET lamp will blink quickly.

If ON/OFF(MAIN) switch is turned to OFF during ASCD is activated, all of ASCD operations will be canceled and vehicle speed memory will be erased.

COAST OPERATION

When the COAST/SET switch is pressed during cruise control driving, decrease vehicle set speed until the switch is released. And then ASCD will keep the new set speed.

RESUME OPERATION

When the ACCEL/RESUME switch is pressed after cancel operation other than depressing ON/OFF(MAIN) switch is performed, vehicle speed will return to last set speed. To resume vehicle set speed, vehicle condition must meet following conditions.

- Brake pedal is released
- Selector lever is in other than P and N positions
- Vehicle speed is greater than 40 km/h (25 MPH) and less than 144 km/h (89 MPH)

Component Description

ASCD STEERING SWITCH

Refer to [EC-515](#) .

ASCD BRAKE SWITCH

Refer to [EC-532](#) , and [EC-624](#) .

STOP LAMP SWITCH

Refer to [EC-532](#) , [EC-550](#) and [EC-624](#) .

ELECTRIC THROTTLE CONTROL ACTUATOR

Refer to [EC-415](#) , [EC-417](#) , [EC-423](#) and [EC-428](#) .

ASCD INDICATOR

Refer to [EC-632](#) .

A

EC

C

D

E

F

G

H

I

J

K

L

M

SERVICE DATA AND SPECIFICATIONS (SDS)

PFP:00030

Fuel Pressure

ABS006ZJ

Fuel pressure at idling kPa (kg/cm ² , psi)	Approximately 350 (3.57, 51)
--	------------------------------

Idle Speed and Ignition Timing

ABS006ZJ

Target idle speed	No-load* ¹ (in P or N position)	650±50 rpm
Air conditioner: ON	In P or N position	775 rpm or more
Ignition timing	In P or N position	15° ± 5° BTDC

*1: Under the following conditions:

- Air conditioner switch: OFF
- Electric load: OFF (Lights, heater fan & rear window defogger)
- Steering wheel: Kept in straight-ahead position

Calculated Load Value

ABS006ZK

	Calculated load value% (Using CONSULT-II or GST)
At idle	5 - 35
At 2,500 rpm	5 - 35

Mass Air Flow Sensor

ABS006ZL

Supply voltage	Battery voltage (11 - 14V)
Output voltage at idle	1.1 - 1.5*V
Mass air flow (Using CONSULT-II or GST)	2.0 - 6.0 g·m/sec at idle* 7.0 - 20.0 g·m/sec at 2,500 rpm*

*: Engine is warmed up to normal operating temperature and running under no-load.

Intake Air Temperature Sensor

ABS006ZM

Temperature °C (°F)	Resistance kΩ
25 (77)	1.94 - 2.06
80 (176)	0.295 - 0.349

Engine Coolant Temperature Sensor

ABS006ZN

Temperature °C (°F)	Resistance kΩ
20 (68)	2.1 - 2.9
50 (122)	0.68 - 1.00
90 (194)	0.236 - 0.260

Heated Oxygen Sensor 1 Heater

ABS006ZO

Resistance [at 25°C (77°F)]	3.3 - 4.0Ω
-----------------------------	------------

Heated Oxygen sensor 2 Heater

ABS006ZP

Resistance [at 25°C (77°F)]	5.0 - 7.0Ω
-----------------------------	------------

Crankshaft Position Sensor (POS)

ABS006ZQ

Refer to [EC-307, "Component Inspection"](#) .

Camshaft Position Sensor (PHASE)

ABS006ZR

Refer to [EC-315, "Component Inspection"](#) .

Throttle Control Motor

ABS006ZS

Resistance [at 25°C (77°F)]	Approximately 1 - 15Ω
-----------------------------	-----------------------

SERVICE DATA AND SPECIFICATIONS (SDS)

[VQ35DE]

Injector

ABS006ZT

Resistance [at 10 - 60°C (50 - 140°F)]

13.5 - 17.5Ω

Fuel Pump

ABS006ZU

Resistance [at 25°C (77°F)]

Approximately 0.2 - 5.0Ω

A

EC

C

D

E

F

G

H

I

J

K

L

M

INDEX FOR DTC

[VK45DE]

INDEX FOR DTC

PFP:00024

Alphabetical Index

ABS00BYV

NOTE:

If DTC U1000 or U1001 is displayed with other DTC, first perform the trouble diagnosis for DTC U1000, U1001. Refer to [EC-792, "DTC U1000, U1001 CAN COMMUNICATION LINE"](#) .

×:Applicable —: Not applicable

Items (CONSULT-II screen terms)	DTC*1		Trip	MIL lighting up	Reference page
	CONSULT-II GST*2	ECM*3			
A/T INTERLOCK	P1730	1730	1	×	AT-147
A/T TCC S/V FNCTN	P0744	0744	2	×	AT-125
ACC COMMAND VALUE*7	P1568	1568	1	×	EC-1188
APP SEN 1/CIRC	P2122	2122	1	×	EC-1225
APP SEN 1/CIRC	P2123	2123	1	×	EC-1225
APP SEN 2/CIRC	P2127	2127	1	×	EC-1232
APP SEN 2/CIRC	P2128	2128	1	×	EC-1232
APP SENSOR	P2138	2138	1	×	EC-1246
ASCD BRAKE SW*7 *8	P1572	1572	1	—	EC-1189 , EC-1199
ASCD SW*7 *8	P1564	1564	1	—	EC-1174 , EC-1181
ASCD VHL SPD SEN*7 *8	P1574	1574	1	—	EC-1207 , EC-1209
ATF TEMP SEN/CIRC	P0710	0710	2	×	AT-139
BRAKE SW/CIRCUIT	P1805	1805	2	—	EC-1220
CAN COMM CIRCUIT	U1000	1000*5	1	× or —	EC-792
CAN COMM CIRCUIT	U1001	1001*5	2	—	EC-792
CKP SEN/CIRCUIT	P0335	0335	2	×	EC-960
CLOSED LOOP-B1	P1148	1148	1	×	EC-1138
CLOSED LOOP-B2	P1168	1168	1	×	EC-1138
CMP SEN/CIRC-B1	P0340	0340	2	×	EC-966
CTP LEARNING	P1225	1225	2	—	EC-1152
CTP LEARNING	P1226	1226	2	—	EC-1154
CYL 1 MISFIRE	P0301	0301	2	×	EC-949
CYL 2 MISFIRE	P0302	0302	2	×	EC-949
CYL 3 MISFIRE	P0303	0303	2	×	EC-949
CYL 4 MISFIRE	P0304	0304	2	×	EC-949
CYL 5 MISFIRE	P0305	0305	2	×	EC-949
CYL 6 MISFIRE	P0306	0306	2	×	EC-949
CYL 7 MISFIRE	P0307	0307	2	×	EC-949
CYL 8 MISFIRE	P0308	0308	2	×	EC-949
D/C SOLENOID/CIRC	P1762	1762	1	×	AT-160
D/C SOLENOID FNCTN	P1764	1764	1	×	AT-162
ECM	P0605	0605	1 or 2	× or —	EC-1057
ECM BACK UP/CIRCUIT	P1065	1065	2	×	EC-1060
ECT SEN/CIRCUIT	P0117	0117	1	×	EC-842

INDEX FOR DTC

[VK45DE]

Items (CONSULT-II screen terms)	DTC*1		Trip	MIL lighting up	Reference page
	CONSULT-II GST*2	ECM*3			
ECT SEN/CIRCUIT	P0118	0118	1	×	EC-842
ECT SENSOR	P0125	0125	1	×	EC-855
ENG OVER TEMP	P1217	1217	1	×	EC-1142
ETC ACTR	P1121	1121	1	×	EC-1077
ETC FUNCTION/CIRC	P1122	1122	1	×	EC-1079
ETC MOT	P1128	1128	1	×	EC-1090
ETC MOT PWR	P1124	1124	1	×	EC-1085
ETC MOT PWR	P1126	1126	1	×	EC-1085
EVAP GROSS LEAK	P0455	0455	2	×	EC-1022
EVAP PURG FLOW/MON	P0441	0441	2	×	EC-976
EVAP SMALL LEAK	P0442	0442	2	×	EC-981
EVAP SYS PRES SEN	P0451	0451	2	×	EC-1004
EVAP SYS PRES SEN	P0452	0452	2	×	EC-1007
EVAP SYS PRES SEN	P0453	0453	2	×	EC-1014
EVAP VERY SML LEAK	P0456	0456	2	×	EC-1030
FR/B SOLENOID FNCT	P1759	1759	1	×	AT-158
FR/B SOLENOID/CIRC	P1757	1757	1	×	AT-156
FTT SEN/CIRCUIT	P0182	0182	2	×	EC-937
FTT SEN/CIRCUIT	P0183	0183	2	×	EC-937
FTT SENSOR	P0181	0181	2	×	EC-931
FUEL LEV SEN SLOSH	P0460	0460	2	×	EC-1040
FUEL LEVEL SENSOR	P0461	0461	2	×	EC-1042
FUEL LEVL SEN/CIRC	P0462	0462	2	×	EC-1044
FUEL LEVL SEN/CIRC	P0463	0463	2	×	EC-1044
FUEL SYS-LEAN-B1	P0171	0171	2	×	EC-914
FUEL SYS-LEAN-B2	P0174	0174	2	×	EC-914
FUEL SYS-RICH-B1	P0172	0172	2	×	EC-923
FUEL SYS-RICH-B2	P0175	0175	2	×	EC-923
HLR/C SOL FNCTN	P1769	1769	1	×	AT-166
HLR/C SOL/CIRC	P1767	1767	1	×	AT-164
HO2S1 (B1)	P0132	0132	2	×	EC-863
HO2S1 (B1)	P0133	0133	2	×	EC-872
HO2S1 (B1)	P0134	0134	2	×	EC-884
HO2S1 (B1)	P1143	1143	2	×	EC-1103
HO2S1 (B1)	P1144	1144	2	×	EC-1109
HO2S1 (B2)	P0152	0152	2	×	EC-863
HO2S1 (B2)	P0153	0153	2	×	EC-872
HO2S1 (B2)	P0154	0154	2	×	EC-884
HO2S1 (B2)	P1163	1163	2	×	EC-1103
HO2S1 (B2)	P1164	1164	2	×	EC-1109
HO2S1 HTR (B1)	P0031	0031	2	×	EC-806
HO2S1 HTR (B1)	P0032	0032	2	×	EC-806

INDEX FOR DTC

[VK45DE]

Items (CONSULT-II screen terms)	DTC*1		Trip	MIL lighting up	Reference page
	CONSULT-II GST*2	ECM*3			
HO2S1 HTR (B2)	P0051	0051	2	×	EC-806
HO2S1 HTR (B2)	P0052	0052	2	×	EC-806
HO2S2 (B1)	P0138	0138	2	×	EC-894
HO2S2 (B1)	P0139	0139	2	×	EC-903
HO2S2 (B1)	P1146	1146	2	×	EC-1116
HO2S2 (B1)	P1147	1147	2	×	EC-1127
HO2S2 (B2)	P0158	0158	2	×	EC-894
HO2S2 (B2)	P0159	0159	2	×	EC-903
HO2S2 (B2)	P1166	1166	2	×	EC-1116
HO2S2 (B2)	P1167	1167	2	×	EC-1127
HO2S2 HTR (B1)	P0037	0037	2	×	EC-814
HO2S2 HTR (B1)	P0038	0038	2	×	EC-814
HO2S2 HTR (B2)	P0057	0057	2	×	EC-814
HO2S2 HTR (B2)	P0058	0058	2	×	EC-814
I/C SOLENOID/CIRC	P1752	1752	1	×	AT-152
I/C SOLENOID FNCTN	P1754	1754	1	×	AT-154
IAT SEN/CIRCUIT	P0112	0112	2	×	EC-837
IAT SEN/CIRCUIT	P0113	0113	2	×	EC-837
IAT SENSOR	P0127	0127	2	×	EC-858
INT/V TIM CONT-B1	P0011	0011	2	×	EC-795
INT/V TIM CONT-B2	P0021	0021	2	×	EC-795
INT/V TIM V/CIR-B1	P1111	1111	2	×	EC-1070
INT/V TIM V/CIR-B2	P1136	1136	2	×	EC-1070
INTK TIM S/CIRC-B1	P1140	1140	2	×	EC-1095
INTK TIM S/CIRC-B2	P1145	1145	2	×	EC-1095
ISC SYSTEM	P0506	0506	2	×	EC-1048
ISC SYSTEM	P0507	0507	2	×	EC-1050
KNOCK SEN/CIRC-B1	P0327	0327	2	—	EC-955
KNOCK SEN/CIRC-B1	P0328	0328	2	—	EC-955
KNOCK SEN/CIRC-B2	P0332	0332	2	—	EC-955
KNOCK SEN/CIRC-B2	P0333	0333	2	—	EC-955
L/PRESS SOL/CIRC	P0745	0745	2	×	AT-127
LC/B SOLENOID FNCT	P1774	1774	1	×	AT-170
LC/B SOLENOID/CIRC	P1772	1772	1	×	AT-168
MAF SEN/CIRCUIT	P0101	0101	1	×	EC-822
MAF SEN/CIRCUIT	P0102	0102	1	×	EC-830
MAF SEN/CIRCUIT	P0103	0103	1	×	EC-830
MAF SENSOR	P1102	1102	1	×	EC-1064
MULTI CYL MISFIRE	P0300	0300	2	×	EC-949
NATS MALFUNCTION	P1610 - P1615	1610 - 1615	2	—	EC-717
NO DTC IS DETECTED. FURTHER TESTING MAY BE REQUIRED.	No DTC	Flashing*4	—	Flashing*4	EC-718

INDEX FOR DTC

[VK45DE]

Items (CONSULT-II screen terms)	DTC*1		Trip	MIL lighting up	Reference page
	CONSULT-II GST*2	ECM*3			
NO DTC IS DETECTED. FURTHER TESTING MAY BE REQUIRED.	P0000	0000	—	—	—
P-N POS SW/CIRCUIT	P1706	1706	2	×	EC-1211
PNP SW/CIRC	P0705	0705	2	×	AT-112
PURG VOLUME CONT/V	P0444	0444	2	×	EC-990
PURG VOLUME CONT/V	P0445	0445	2	×	EC-990
PURG VOLUME CONT/V	P1444	1444	2	×	EC-1160
PW ST P SEN/CIRC	P0550	0550	2	—	EC-1052
SENSOR POWER/CIRC	P1229	1229	1	×	EC-1156
SHIFT SIG FNCTN	P1780	1780	2	—	EC-1218
TCC SOLENOID/CIRC	P0740	0740	2	×	AT-123
TCS C/U FUNCTN	P1211	1211	2	—	EC-1140
TCS/CIRC	P1212	1212	2	—	EC-1141
THERMSTAT FNCTN	P0128	0128	2	×	EC-861
TP SEN 1/CIRC	P0222	0222	1	×	EC-942
TP SEN 1/CIRC	P0223	0223	1	×	EC-942
TP SEN 2/CIRC	P0122	0122	1	×	EC-848
TP SEN 2/CIRC	P0123	0123	1	×	EC-848
TP SENSOR	P2135	2135	1	×	EC-1239
TURBINE REV S/CIRC	P1716	1716	2	×	AT-143
TW CATALYST SYS-B1	P0420	0420	2	×	EC-971
TW CATALYST SYS-B2	P0430	0430	2	×	EC-971
V/SP SEN(A/T OUT)	P1720	1720	2	—	EC-1216
VEH SPD SEN/CIR AT*6	P0720	0720	2	×	AT-116
VEH SPEED SEN/CIRC*6	P0500	0500	2	×	EC-1046
VENT CONTROL VALVE	P0447	0447	2	×	EC-997
VENT CONTROL VALVE	P1446	1446	2	×	EC-1168

*1: 1st trip DTC No. is the same as DTC No.

*2: This number is prescribed by SAE J2012.

*3: In Diagnostic Test Mode II (Self-diagnostic results). This number is controlled by NISSAN.

*4: When engine is running.

*5: The troubleshooting for this DTC needs CONSULT-II.

*6: When the fail-safe operations for both self-diagnoses occur at the same time, the MIL illuminates.

*7: Models with ICC

*8: Models with ASCD

DTC No. Index

ABS00BYW

NOTE:

If DTC U1000 or U1001 is displayed with other DTC, first perform the trouble diagnosis for DTC U1000, U1001. Refer to [EC-792, "DTC U1000, U1001 CAN COMMUNICATION LINE"](#) .

INDEX FOR DTC

[VK45DE]

×:Applicable —: Not applicable

DTC*1		Items (CONSULT-II screen terms)	Trip	MIL lighting up	Reference page
CONSULT-II GST*2	ECM*3				
No DTC	Flashing*4	NO DTC IS DETECTED. FURTHER TESTING MAY BE REQUIRED.	—	Flashing*4	EC-718
U1000	1000*5	CAN COMM CIRCUIT	1	× or —	EC-792
U1001	1001*5	CAN COMM CIRCUIT	2	—	EC-792
P0000	0000	NO DTC IS DETECTED. FURTHER TESTING MAY BE REQUIRED.	—	—	—
P0011	0011	INT/V TIM CONT-B1	2	×	EC-795
P0021	0021	INT/V TIM CONT-B2	2	×	EC-795
P0031	0031	HO2S1 HTR (B1)	2	×	EC-806
P0032	0032	HO2S1 HTR (B1)	2	×	EC-806
P0037	0037	HO2S2 HTR (B1)	2	×	EC-814
P0038	0038	HO2S2 HTR (B1)	2	×	EC-814
P0051	0051	HO2S1 HTR (B2)	2	×	EC-806
P0052	0052	HO2S1 HTR (B2)	2	×	EC-806
P0057	0057	HO2S2 HTR (B2)	2	×	EC-814
P0058	0058	HO2S2 HTR (B2)	2	×	EC-814
P0101	0101	MAF SEN/CIRCUIT	1	×	EC-822
P0102	0102	MAF SEN/CIRCUIT	1	×	EC-830
P0103	0103	MAF SEN/CIRCUIT	1	×	EC-830
P0112	0112	IAT SEN/CIRCUIT	2	×	EC-837
P0113	0113	IAT SEN/CIRCUIT	2	×	EC-837
P0117	0117	ECT SEN/CIRCUIT	1	×	EC-842
P0118	0118	ECT SEN/CIRCUIT	1	×	EC-842
P0122	0122	TP SEN 2/CIRC	1	×	EC-848
P0123	0123	TP SEN 2/CIRC	1	×	EC-848
P0125	0125	ECT SENSOR	1	×	EC-855
P0127	0127	IAT SENSOR	2	×	EC-858
P0128	0128	THERMSTAT FNCTN	2	×	EC-861
P0132	0132	HO2S1 (B1)	2	×	EC-863
P0133	0133	HO2S1 (B1)	2	×	EC-872
P0134	0134	HO2S1 (B1)	2	×	EC-884
P0138	0138	HO2S2 (B1)	2	×	EC-894
P0139	0139	HO2S2 (B1)	2	×	EC-903
P0152	0152	HO2S1 (B2)	2	×	EC-863
P0153	0153	HO2S1 (B2)	2	×	EC-872
P0154	0154	HO2S1 (B2)	2	×	EC-884
P0158	0158	HO2S2 (B2)	2	×	EC-894
P0159	0159	HO2S2 (B2)	2	×	EC-903
P0171	0171	FUEL SYS-LEAN-B1	2	×	EC-914
P0172	0172	FUEL SYS-RICH-B1	2	×	EC-923
P0174	0174	FUEL SYS-LEAN-B2	2	×	EC-914

INDEX FOR DTC

[VK45DE]

DTC*1		Items (CONSULT-II screen terms)	Trip	MIL lighting up	Reference page
CONSULT-II GST*2	ECM*3				
P0175	0175	FUEL SYS-RICH-B2	2	×	EC-923
P0181	0181	FTT SENSOR	2	×	EC-931
P0182	0182	FTT SEN/CIRCUIT	2	×	EC-937
P0183	0183	FTT SEN/CIRCUIT	2	×	EC-937
P0222	0222	TP SEN 1/CIRC	1	×	EC-942
P0223	0223	TP SEN 1/CIRC	1	×	EC-942
P0300	0300	MULTI CYL MISFIRE	2	×	EC-949
P0301	0301	CYL 1 MISFIRE	2	×	EC-949
P0302	0302	CYL 2 MISFIRE	2	×	EC-949
P0303	0303	CYL 3 MISFIRE	2	×	EC-949
P0304	0304	CYL 4 MISFIRE	2	×	EC-949
P0305	0305	CYL 5 MISFIRE	2	×	EC-949
P0306	0306	CYL 6 MISFIRE	2	×	EC-949
P0307	0307	CYL 7 MISFIRE	2	×	EC-949
P0308	0308	CYL 8 MISFIRE	2	×	EC-949
P0327	0327	KNOCK SEN/CIRC-B1	2	—	EC-955
P0328	0328	KNOCK SEN/CIRC-B1	2	—	EC-955
P0332	0332	KNOCK SEN/CIRC-B2	2	—	EC-955
P0333	0333	KNOCK SEN/CIRC-B2	2	—	EC-955
P0335	0335	CKP SEN/CIRCUIT	2	×	EC-960
P0340	0340	CMP SEN/CIRC-B1	2	×	EC-966
P0420	0420	TW CATALYST SYS-B1	2	×	EC-971
P0430	0430	TW CATALYST SYS-B2	2	×	EC-971
P0441	0441	EVAP PURG FLOW/MON	2	×	EC-976
P0442	0442	EVAP SMALL LEAK	2	×	EC-981
P0444	0444	PURG VOLUME CONT/V	2	×	EC-990
P0445	0445	PURG VOLUME CONT/V	2	×	EC-990
P0447	0447	VENT CONTROL VALVE	2	×	EC-997
P0451	0451	EVAP SYS PRES SEN	2	×	EC-1004
P0452	0452	EVAP SYS PRES SEN	2	×	EC-1007
P0453	0453	EVAP SYS PRES SEN	2	×	EC-1014
P0455	0455	EVAP GROSS LEAK	2	×	EC-1022
P0456	0456	EVAP VERY SML LEAK	2	×	EC-1030
P0460	0460	FUEL LEV SEN SLOSH	2	×	EC-1040
P0461	0461	FUEL LEVEL SENSOR	2	×	EC-1042
P0462	0462	FUEL LEVL SEN/CIRC	2	×	EC-1044
P0463	0463	FUEL LEVL SEN/CIRC	2	×	EC-1044
P0500	0500	VEH SPEED SEN/CIRC*6	2	×	EC-1046
P0506	0506	ISC SYSTEM	2	×	EC-1048
P0507	0507	ISC SYSTEM	2	×	EC-1050
P0550	0550	PW ST P SEN/CIRC	2	—	EC-1052
P0605	0605	ECM	1 or 2	× or —	EC-1057

INDEX FOR DTC

[VK45DE]

DTC*1		Items (CONSULT-II screen terms)	Trip	MIL lighting up	Reference page
CONSULT-II GST*2	ECM*3				
P0705	0705	PNP SW/CIRC	2	×	AT-112
P0710	0710	ATF TEMP SEN/CIRC	2	×	AT-139
P0720	0720	VEH SPD SEN/CIR AT*6	2	×	AT-116
P0740	0740	TCC SOLENOID/CIRC	2	×	AT-123
P0744	0744	A/T TCC S/V FNCTN	2	×	AT-125
P0745	0745	L/PRESS SOL/CIRC	2	×	AT-127
P1065	1065	ECM BACK UP/CIRCUIT	2	×	EC-1060
P1102	1102	MAF SENSOR	1	×	EC-1064
P1111	1111	INT/V TIM V/CIR-B1	2	×	EC-1070
P1121	1121	ETC ACTR	1	×	EC-1077
P1122	1122	ETC FUNCTION/CIRC	1	×	EC-1079
P1124	1124	ETC MOT PWR	1	×	EC-1085
P1126	1126	ETC MOT PWR	1	×	EC-1085
P1128	1128	ETC MOT	1	×	EC-1090
P1136	1136	INT/V TIM V/CIR-B2	2	×	EC-1070
P1140	1140	INTK TIM S/CIRC-B1	2	×	EC-1095
P1143	1143	HO2S1 (B1)	2	×	EC-1103
P1144	1144	HO2S1 (B1)	2	×	EC-1109
P1145	1145	INTK TIM S/CIRC-B2	2	×	EC-1095
P1146	1146	HO2S2 (B1)	2	×	EC-1116
P1147	1147	HO2S2 (B1)	2	×	EC-1127
P1148	1148	CLOSED LOOP-B1	1	×	EC-1138
P1163	1163	HO2S1 (B2)	2	×	EC-1103
P1164	1164	HO2S1 (B2)	2	×	EC-1109
P1166	1166	HO2S2 (B2)	2	×	EC-1116
P1167	1167	HO2S2 (B2)	2	×	EC-1127
P1168	1168	CLOSED LOOP-B2	1	×	EC-1138
P1211	1211	TCS C/U FUNCTN	2	—	EC-1140
P1212	1212	TCS/CIRC	2	—	EC-1141
P1217	1217	ENG OVER TEMP	1	×	EC-1142
P1225	1225	CTP LEARNING	2	—	EC-1152
P1226	1226	CTP LEARNING	2	—	EC-1154
P1229	1229	SENSOR POWER/CIRC	1	×	EC-1156
P1444	1444	PURG VOLUME CONT/V	2	×	EC-1160
P1446	1446	VENT CONTROL VALVE	2	×	EC-1168
P1564	1564	ASCD SW*7 *8	1	—	EC-1174, EC-1181
P1568	1568	ACC COMMAND VALUE*7	1	—	EC-1188
P1572	1572	ASCD BRAKE SW*7 *8	1	—	EC-1189, EC-1199
P1574	1574	ASCD VHL SPD SEN*7 *8	1	—	EC-1207, EC-1209
P1610 - P1615	1610 - 1615	NATS MALFUNCTION	2	—	EC-717

INDEX FOR DTC

[VK45DE]

DTC*1		Items (CONSULT-II screen terms)	Trip	MIL lighting up	Reference page
CONSULT-II GST*2	ECM*3				
P1706	1706	P-N POS SW/CIRCUIT	2	×	EC-1211
P1716	1716	TURBINE REV S/CIRC	2	×	AT-143
P1720	1720	V/SP SEN (A/T OUT)	2	—	EC-1216
P1730	1730	A/T INTERLOCK	1	×	AT-147
P1752	1752	I/C SOLENOID/CIRC	1	×	AT-152
P1754	1754	I/C SOLENOID FNCTN	1	×	AT-154
P1757	1757	FR/B SOLENOID/CIRC	1	×	AT-156
P1759	1759	FR/B SOLENOID FNCT	1	×	AT-158
P1762	1762	D/C SOLENOID/CIRC	1	×	AT-160
P1764	1764	D/C SOLENOID FNCTN	1	×	AT-162
P1767	1767	HLR/C SOL/CIRC	1	×	AT-164
P1769	1769	HLR/C SOL FNCTN	1	×	AT-166
P1772	1772	LC/B SOLENOID/CIRC	1	×	AT-168
P1774	1774	LC/B SOLENOID FNCT	1	×	AT-170
P1780	1780	SHIFT SIG FNCTN	2	—	EC-1218
P1805	1805	BRAKE SW/CIRCUIT	2	—	EC-1220
P2122	2122	APP SEN 1/CIRC	1	×	EC-1225
P2123	2123	APP SEN 1/CIRC	1	×	EC-1225
P2127	2127	APP SEN 2/CIRC	1	×	EC-1232
P2128	2128	APP SEN 2/CIRC	1	×	EC-1232
P2135	2135	TP SENSOR	1	×	EC-1239
P2138	2138	APP SENSOR	1	×	EC-1246

*1: 1st trip DTC No. is the same as DTC No.

*2: This number is prescribed by SAE J2012.

*3: In Diagnostic Test Mode II (Self-diagnostic results). This number is controlled by NISSAN.

*4: When engine is running.

*5: The troubleshooting for this DTC needs CONSULT-II.

*6: When the fail-safe operations for both self-diagnoses occur at the same time, the MIL illuminates.

*7: Models with ICC

*8: Models with ASCD

PRECAUTIONS

PFP:00001

Precautions for Supplemental Restraint System (SRS) “AIR BAG” and “SEAT BELT PRE-TENSIONER”

ABS00BYX

The Supplemental Restraint System such as “AIR BAG” and “SEAT BELT PRE-TENSIONER”, used along with a front seat belt, helps to reduce the risk or severity of injury to the driver and front passenger for certain types of collision. This system includes seat belt switch inputs and dual stage front air bag modules. The SRS system uses the seat belt switches to determine the front air bag deployment, and may only deploy one front air bag, depending on the severity of a collision and whether the front occupants are belted or unbelted. Information necessary to service the system safely is included in the SRS and SB section of this Service Manual.

WARNING:

- To avoid rendering the SRS inoperative, which could increase the risk of personal injury or death in the event of a collision which would result in air bag inflation, all maintenance must be performed by an authorized NISSAN/INFINITI dealer.
- Improper maintenance, including incorrect removal and installation of the SRS, can lead to personal injury caused by unintentional activation of the system. For removal of Spiral Cable and Air Bag Module, see the SRS section.
- Do not use electrical test equipment on any circuit related to the SRS unless instructed to in this Service Manual. SRS wiring harnesses can be identified by yellow and/or orange harnesses or harness connectors.

On Board Diagnostic (OBD) System of Engine and A/T

ABS00BYX

The ECM has an on board diagnostic system. It will light up the malfunction indicator lamp (MIL) to warn the driver of a malfunction causing emission deterioration.

CAUTION:

- Be sure to turn the ignition switch OFF and disconnect the negative battery cable before any repair or inspection work. The open/short circuit of related switches, sensors, solenoid valves, etc. will cause the MIL to light up.
- Be sure to connect and lock the connectors securely after work. A loose (unlocked) connector will cause the MIL to light up due to the open circuit. (Be sure the connector is free from water, grease, dirt, bent terminals, etc.)
- Certain systems and components, especially those related to OBD, may use a new style slide-locking type harness connector. For description and how to disconnect, refer to [PG-74, "HARN-NESS CONNECTOR"](#) .
- Be sure to route and secure the harnesses properly after work. The interference of the harness with a bracket, etc. may cause the MIL to light up due to the short circuit.
- Be sure to connect rubber tubes properly after work. A misconnected or disconnected rubber tube may cause the MIL to light up due to the malfunction of the EVAP system or fuel injection system, etc.
- Be sure to erase the unnecessary malfunction information (repairs completed) from the ECM and TCM (Transmission control module) before returning the vehicle to the customer.

Precaution

ABS00BYZ

- Always use a 12 volt battery as power source.
- Do not attempt to disconnect battery cables while engine is running.
- Before connecting or disconnecting the ECM harness connector, turn ignition switch OFF and disconnect negative battery cable. Failure to do so may damage the ECM because battery voltage is applied to ECM even if ignition switch is turned OFF.
- Before removing parts, turn ignition switch OFF and then disconnect battery ground cable.

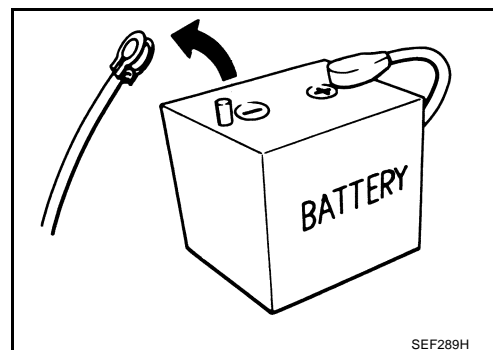

PRECAUTIONS

[VK45DE]

- Do not disassemble ECM.
- If a battery cable is disconnected, the memory will return to the ECM value.
The ECM will now start to self-control at its initial value. Engine operation can vary slightly when the terminal is disconnected. However, this is not an indication of a malfunction. Do not replace parts because of a slight variation.

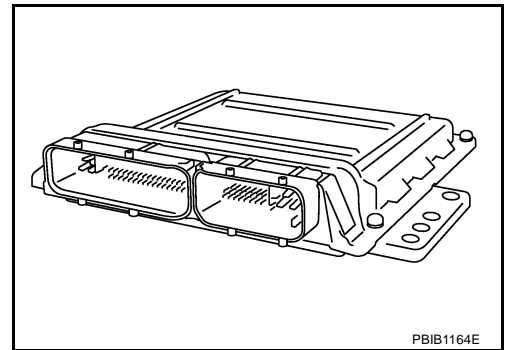

- When connecting ECM harness connector, fasten it securely with a lever as far as it will go as shown in the figure.

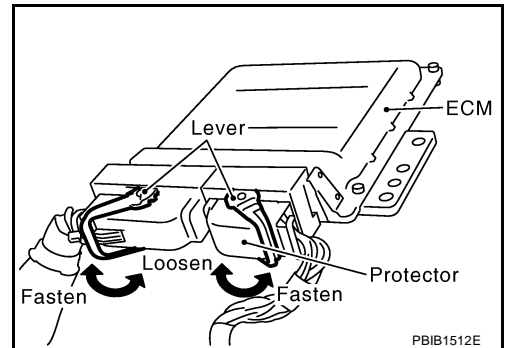

- When connecting or disconnecting pin connectors into or from ECM, take care not to damage pin terminals (bend or break).
Make sure that there are not any bends or breaks on ECM pin terminal, when connecting pin connectors.

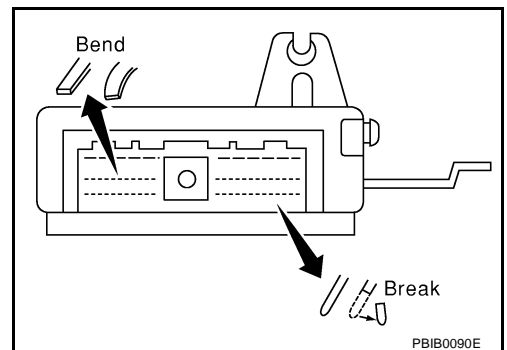

- Securely connect ECM harness connectors.
A poor connection can cause an extremely high (surge) voltage to develop in coil and condenser, thus resulting in damage to ICs.
- Keep engine control system harness at least 10 cm (4 in) away from adjacent harness, to prevent engine control system malfunctions due to receiving external noise, degraded operation of ICs, etc.
- Keep engine control system parts and harness dry.
- Before replacing ECM, perform ECM Terminals and Reference Value inspection and make sure ECM functions properly. Refer to [EC-750](#).
- Handle mass air flow sensor carefully to avoid damage.
- Do not disassemble mass air flow sensor.
- Do not clean mass air flow sensor with any type of detergent.
- Do not disassemble electric throttle control actuator.
- Even a slight leak in the air intake system can cause serious incidents.
- Do not shock or jar the camshaft position sensor (PHASE), crankshaft position sensor (POS).

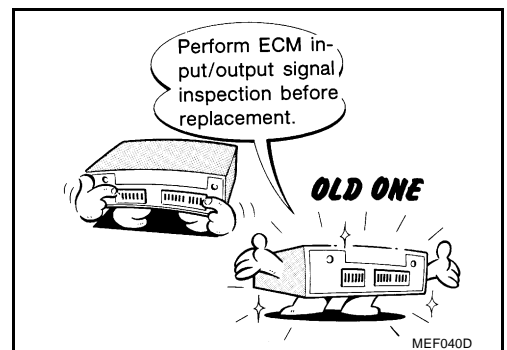

A
EC
C
D
E
F
G
H
I
J
K
L
M

PRECAUTIONS

[VK45DE]

- After performing each TROUBLE DIAGNOSIS, perform DTC Confirmation Procedure or Overall Function Check. The DTC should not be displayed in the DTC Confirmation Procedure if the repair is completed. The Overall Function Check should be a good result if the repair is completed.

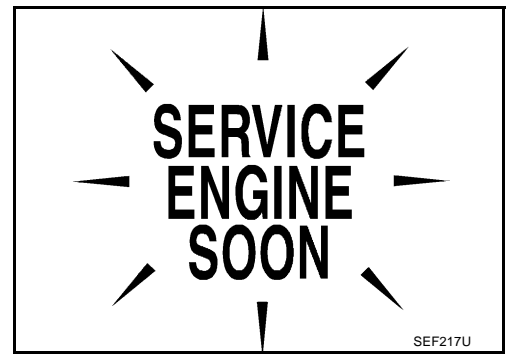

- When measuring ECM signals with a circuit tester, never allow the two tester probes to contact. Accidental contact of probes will cause a short circuit and damage the ECM power transistor.
- Do not use ECM ground terminals when measuring input/output voltage. Doing so may result in damage to the ECM's transistor. Use a ground other than ECM terminals, such as the ground.

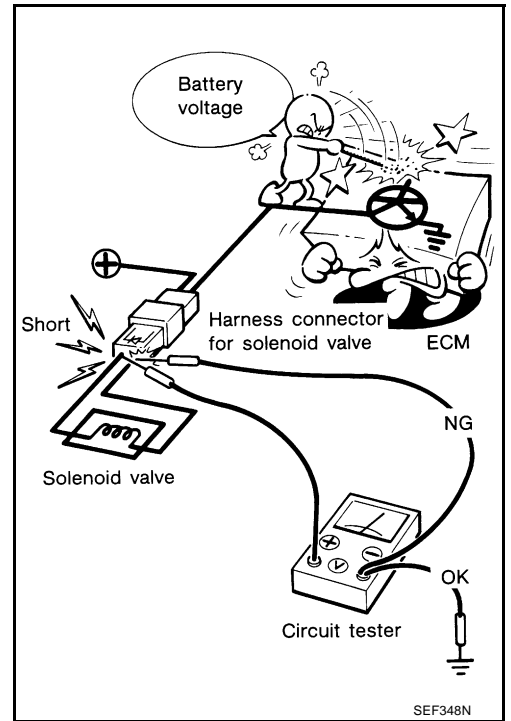

- B1 indicates the bank 1, B2 indicates the bank 2 as shown in the figure.

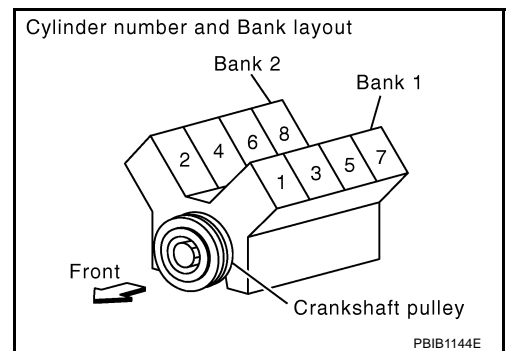

PRECAUTIONS

[VK45DE]

- Do not operate fuel pump when there is no fuel in lines.
- Tighten fuel hose clamps to the specified torque.

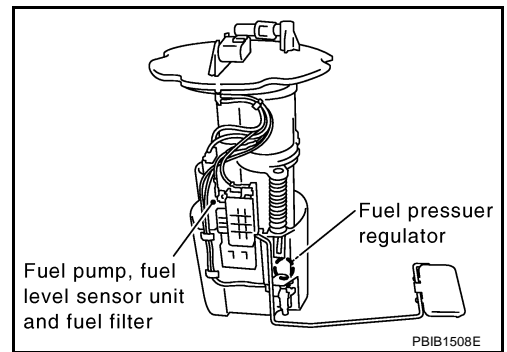

- Do not depress accelerator pedal when starting.
- Immediately after starting, do not rev up engine unnecessarily.
- Do not rev up engine just prior to shutdown.



- When installing C.B. ham radio or a mobile phone, be sure to observe the following as it may adversely affect electronic control systems depending on installation location.
 - Keep the antenna as far as possible from the electronic control units.
 - Keep the antenna feeder line more than 20 cm (8 in) away from the harness of electronic controls. Do not let them run parallel for a long distance.
 - Adjust the antenna and feeder line so that the standing-wave ratio can be kept smaller.
 - Be sure to ground the radio to vehicle body.

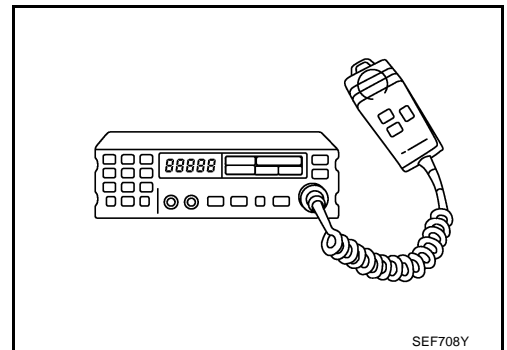

Wiring Diagrams and Trouble Diagnosis

ABS00BZ0

When you read wiring diagrams, refer to the following:

- [GI-15, "How to Read Wiring Diagrams"](#)
- [PG-3, "POWER SUPPLY ROUTING CIRCUIT"](#) for power distribution circuit

When you perform trouble diagnosis, refer to the following:

- [GI-11, "HOW TO FOLLOW TEST GROUPS IN TROUBLE DIAGNOSES"](#)
- [GI-27, "How to Perform Efficient Diagnosis for an Electrical Incident"](#)

A
EC
C
D
E
F
G
H
I
J
K
L
M

PREPARATION

PFP:00002

Special Service Tools

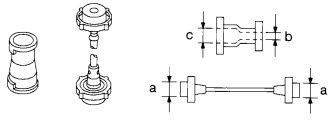
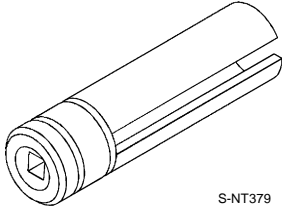
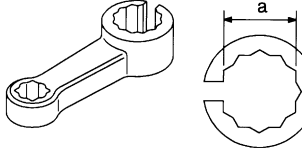
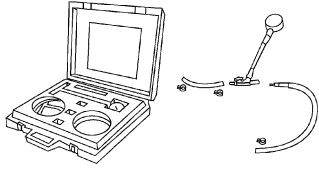
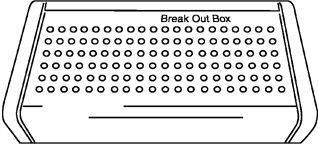
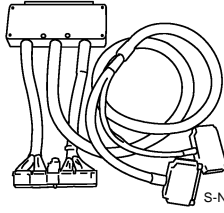

ABS00BZ1

The actual shapes of Kent-Moore tools may differ from those of special service tools illustrated here.

Tool number (Kent-Moore No.) Tool name	Description
EG17650301 (J-33984-A) Radiator cap tester adapter  S-NT564	Adapting radiator cap tester to radiator cap and radiator filler neck a: 28 (1.10) dia. b: 31.4 (1.236) dia. c: 41.3 (1.626) dia. Unit: mm (in)
KV10117100 (J-36471-A) Heated oxygen sensor wrench  S-NT379	Loosening or tightening heated oxygen sensors with 22 mm (0.87 in) hexagon nut
KV10114400 (J-38365) Heated oxygen sensor wrench  S-NT636	Loosening or tightening heated oxygen sensors a: 22 mm (0.87 in)
(J-44321) Fuel pressure gauge kit  LEC642	Checking fuel pressure
KV109E0010 (J-46209) Break-out box  S-NT825	Measuring the ECM signals with a circuit tester
KV109E0080 (J-45819) Y-cable adapter  S-NT826	Measuring the ECM signals with a circuit tester

Commercial Service Tools

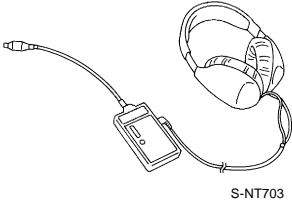
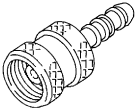
ABS00BZ2

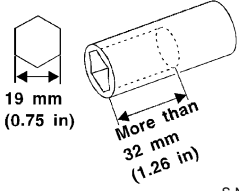
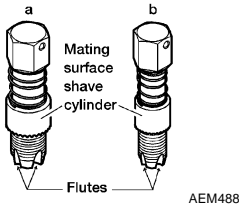
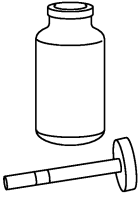
Tool name (Kent-Moore No.)	Description
Leak detector i.e.: (J-41416)	Locating the EVAP leak
 <p style="text-align: center;">S-NT703</p>	
EVAP service port adapter i.e.: (J-41413-OBD)	Applying positive pressure through EVAP service port
 <p style="text-align: center;">S-NT704</p>	
Fuel filler cap adapter i.e.: (MLR-8382)	Checking fuel tank vacuum relief valve opening pressure
 <p style="text-align: center;">S-NT815</p>	
Socket wrench	Removing and installing engine coolant temperature sensor
 <p style="text-align: center;">S-NT705</p>	
Oxygen sensor thread cleaner i.e.: (J-43897-18) (J-43897-12)	Reconditioning the exhaust system threads before installing a new oxygen sensor. Use with anti-seize lubricant shown below. a: 18 mm diameter with pitch 1.5 mm for Zirconia Oxygen Sensor b: 12 mm diameter with pitch 1.25 mm for Titania Oxygen Sensor
 <p style="text-align: center;">AEM488</p>	
Anti-seize lubricant i.e.: (Permatex™ 133AR or equivalent meeting MIL specification MIL-A-907)	Lubricating oxygen sensor thread cleaning tool when reconditioning exhaust system threads.
 <p style="text-align: center;">S-NT779</p>	

A
EC
C
D
E
F
G
H
I
J
K
L
M

ENGINE CONTROL SYSTEM

PFP:23710

System Diagram

ABS00BZ3

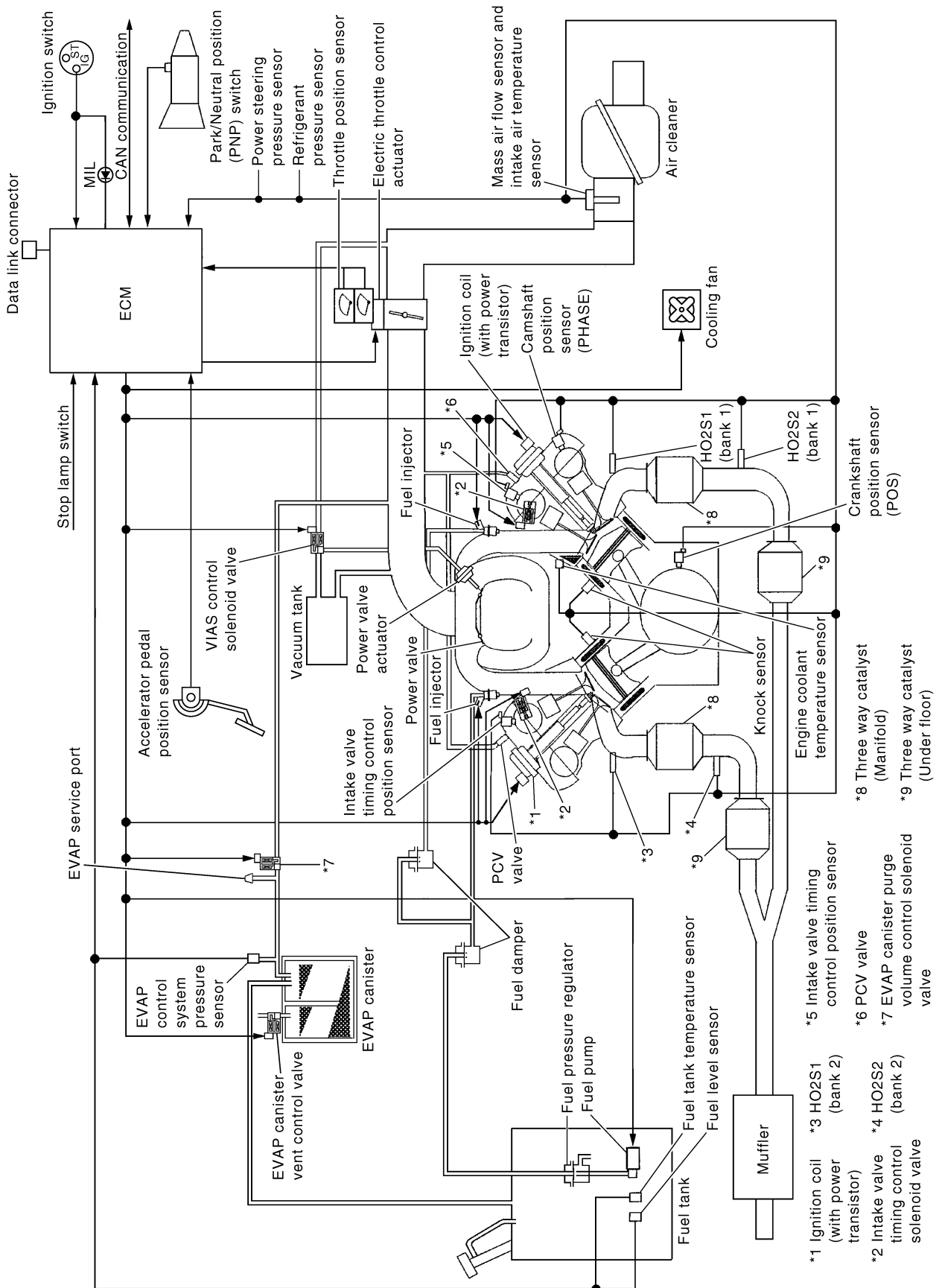

PBIB2296E

Vacuum Hose Drawing

ABS00BZ4

A

EC

C

D

E

F

G

H

I

J

K

L

M

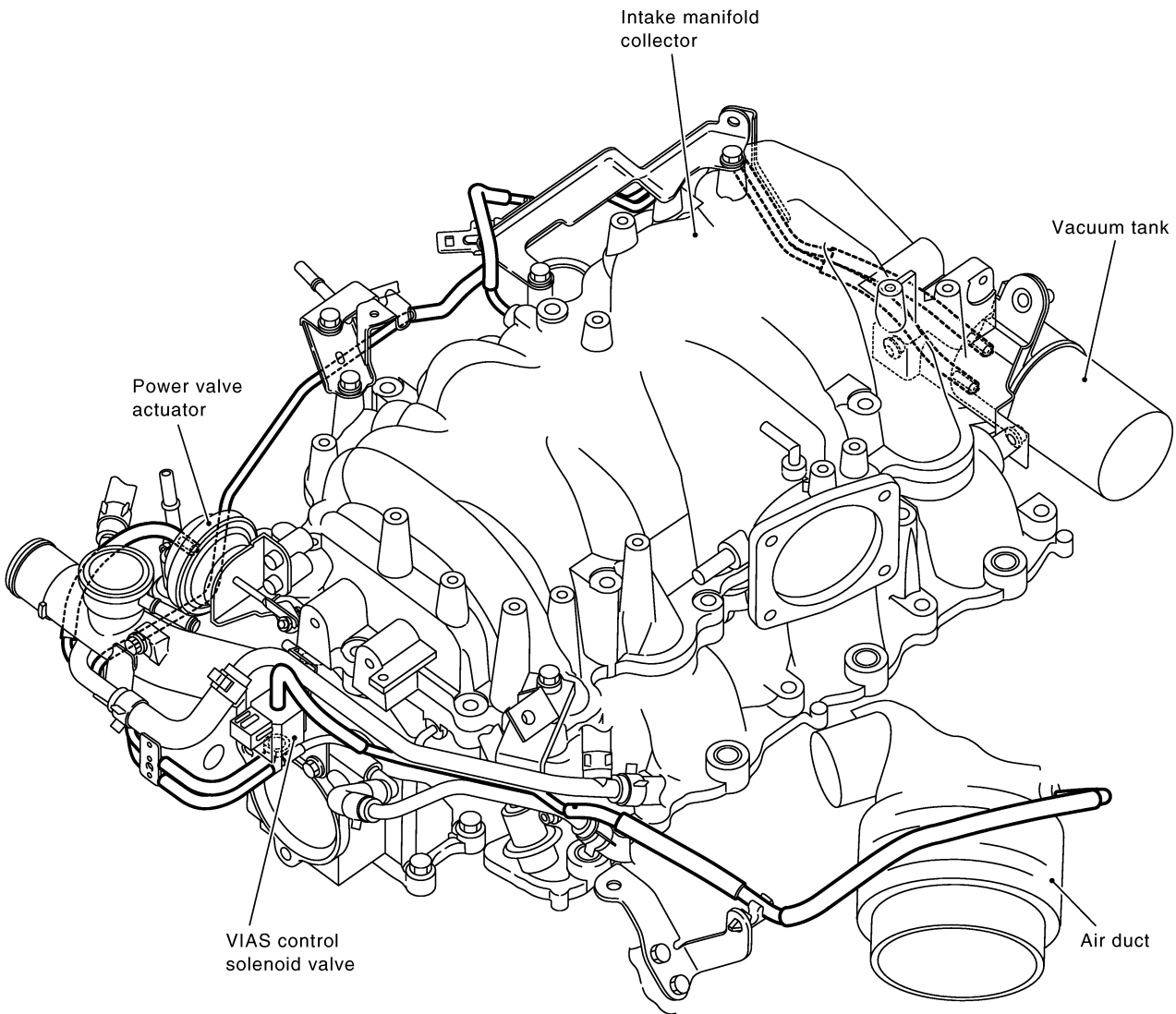

NOTE:

Do not use soapy water or any type of solvent while installing vacuum hoses or purge hoses.

PBIB1143E

Refer to [EC-676, "System Diagram"](#) for Vacuum Control System.

ENGINE CONTROL SYSTEM

[VK45DE]

ABS00BZ5

System Chart

Input (Sensor)	ECM Function	Output (Actuator)	
<ul style="list-style-type: none"> ● Camshaft position sensor (PHASE) ● Crankshaft position sensor (POS) ● Intake valve timing control position sensor ● Mass air flow sensor ● Engine coolant temperature sensor ● Heated oxygen sensor 1 ● Throttle position sensor ● Accelerator pedal position sensor ● Park/neutral position (PNP) switch ● Intake air temperature sensor ● Power steering pressure sensor ● Ignition switch ● Battery voltage ● Knock sensor ● Refrigerant pressure sensor ● Stop lamp switch ● ICC steering switch ● ICC brake switch ● ASCD steering switch ● ASCD brake switch ● Fuel level sensor*¹ *³ ● EVAP control system pressure sensor ● Fuel tank temperature sensor*¹ ● Heated oxygen sensor 2*² ● TCM (Transmission control module)*³ ● ABS actuator and electric unit (control unit)*³ ● ICC unit*³ ● Air conditioner switch*³ ● Wheel sensor*³ ● Electrical load signal*³ 	Fuel injection & mixture ratio control	Fuel injector	
	Electronic ignition system	Power transistor	
	Nissan torque demand control system	<ul style="list-style-type: none"> ● Electric throttle control actuator ● Fuel injector 	
	Fuel pump control	Fuel pump relay	
	ICC vehicle speed control	Electric throttle control actuator	
	ASCD vehicle speed control		
	On board diagnostic system	MIL (On the instrument panel)* ⁴	
	Power valve control	VIAS control solenoid valve	
	Intake valve timing control	Intake valve timing control solenoid valve	
	Heated oxygen sensor 1 heater control	Heated oxygen sensor 1 heater	
	Heated oxygen sensor 2 heater control	Heated oxygen sensor 2 heater	
	EVAP canister purge flow control	EVAP canister purge volume control solenoid valve	
	Air conditioning cut control	Air conditioner relay* ⁴	
	Cooling fan control	Cooling fan relay* ⁴	
		ON BOARD DIAGNOSIS for EVAP system	EVAP canister vent control valve

*1: This sensor is not used to control the engine system. This is used only for the on board diagnosis.

*2: This sensor is not used to control the engine system under normal conditions.

*3: This input signal is sent to the ECM through CAN communication line.

*4: This output signal is sent from the ECM through CAN communication line.

Multipoint Fuel Injection (MFI) System INPUT/OUTPUT SIGNAL CHART

Sensor	Input signal to ECM	ECM function	Actuator
Crankshaft position sensor (POS)	Engine speed*3 Piston position	Fuel injection & mixture ratio control	Fuel injector
Camshaft position sensor (PHASE)			
Mass air flow sensor	Amount of intake air		
Engine coolant temperature sensor	Engine coolant temperature		
Heated oxygen sensor 1	Density of oxygen in exhaust gas		
Throttle position sensor	Throttle position		
Accelerator pedal position sensor	Accelerator pedal position		
Park/neutral position (PNP) switch	Gear position		
Knock sensor	Engine knocking condition		
Battery	Battery voltage*3		
Power steering pressure sensor	Power steering operation		
Heated oxygen sensor 2*1	Density of oxygen in exhaust gas		
ABS actuator and electric unit (control unit)*2	VDC/TCS operation command		
Air conditioner switch*2	Air conditioner operation		
Wheel sensor*2	Vehicle speed		

*1: This sensor is not used to control the engine system under normal conditions.

*2: This signal is sent to the ECM through CAN communication line.

*3: ECM determines the start signal status by the signals of engine speed and battery voltage.

SYSTEM DESCRIPTION

The amount of fuel injected from the fuel injector is determined by the ECM. The ECM controls the length of time the valve remains open (injection pulse duration). The amount of fuel injected is a program value in the ECM memory. The program value is preset by engine operating conditions. These conditions are determined by input signals (for engine speed and intake air) from both the crankshaft position sensor (POS), camshaft position sensor (PHASE) and the mass air flow sensor.

VARIOUS FUEL INJECTION INCREASE/DECREASE COMPENSATION

In addition, the amount of fuel injected is compensated to improve engine performance under various operating conditions as listed below.

<Fuel increase>

- During warm-up
- When starting the engine
- During acceleration
- Hot-engine operation
- When selector lever is changed from N to D
- High-load, high-speed operation

<Fuel decrease>

- During deceleration
- During high engine speed operation

MIXTURE RATIO FEEDBACK CONTROL (CLOSED LOOP CONTROL)

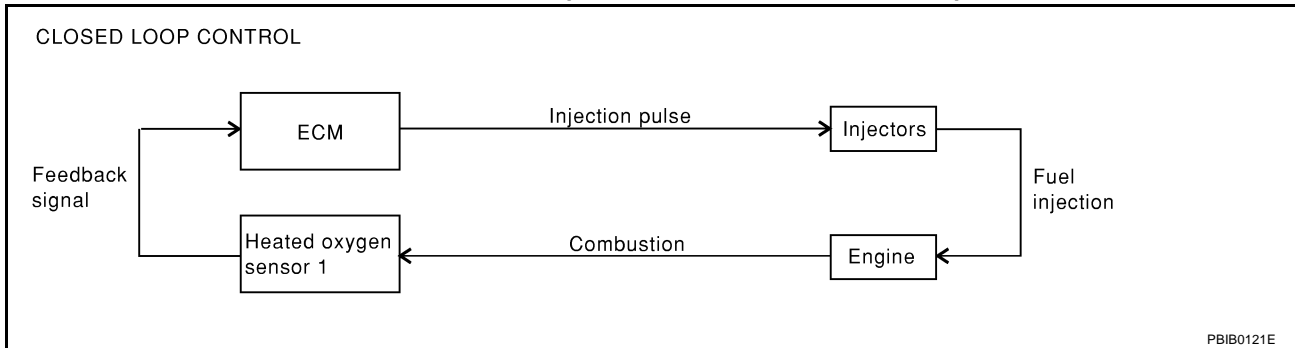

The mixture ratio feedback system provides the best air-fuel mixture ratio for driveability and emission control. The three way catalyst (manifold) can then better reduce CO, HC and NOx emissions. This system uses heated oxygen sensor 1 in the exhaust manifold to monitor whether the engine operation is rich or lean. The ECM adjusts the injection pulse width according to the sensor voltage signal. For more information about heated oxygen sensor 1, refer to [EC-863](#). This maintains the mixture ratio within the range of stoichiometric (ideal air-fuel mixture).

This stage is referred to as the closed loop control condition.

Heated oxygen sensor 2 is located downstream of the three way catalyst (manifold). Even if the switching characteristics of heated oxygen sensor 1 shift, the air-fuel ratio is controlled to stoichiometric by the signal from heated oxygen sensor 2.

Open Loop Control

The open loop system condition refers to when the ECM detects any of the following conditions. Feedback control stops in order to maintain stabilized fuel combustion.

- Deceleration and acceleration
- High-load, high-speed operation
- Malfunction of heated oxygen sensor 1 or its circuit
- Insufficient activation of heated oxygen sensor 1 at low engine coolant temperature
- High engine coolant temperature
- During warm-up
- After shifting from N to D
- When starting the engine

MIXTURE RATIO SELF-LEARNING CONTROL

The mixture ratio feedback control system monitors the mixture ratio signal transmitted from heated oxygen sensor 1. This feedback signal is then sent to the ECM. The ECM controls the basic mixture ratio as close to the theoretical mixture ratio as possible. However, the basic mixture ratio is not necessarily controlled as originally designed. Both manufacturing differences (i.e., mass air flow sensor hot film) and characteristic changes during operation (i.e., injector clogging) directly affect mixture ratio.

Accordingly, the difference between the basic and theoretical mixture ratios is monitored in this system. This is then computed in terms of "injection pulse duration" to automatically compensate for the difference between the two ratios.

"Fuel trim" refers to the feedback compensation value compared against the basic injection duration. Fuel trim includes short term fuel trim and long term fuel trim.

"Short term fuel trim" is the short-term fuel compensation used to maintain the mixture ratio at its theoretical value. The signal from heated oxygen sensor 1 indicates whether the mixture ratio is RICH or LEAN compared to the theoretical value. The signal then triggers a reduction in fuel volume if the mixture ratio is rich, and an increase in fuel volume if it is lean.

"Long term fuel trim" is overall fuel compensation carried out long-term to compensate for continual deviation of the short term fuel trim from the central value. Such deviation will occur due to individual engine differences, wear over time and changes in the usage environment.

FUEL INJECTION TIMING

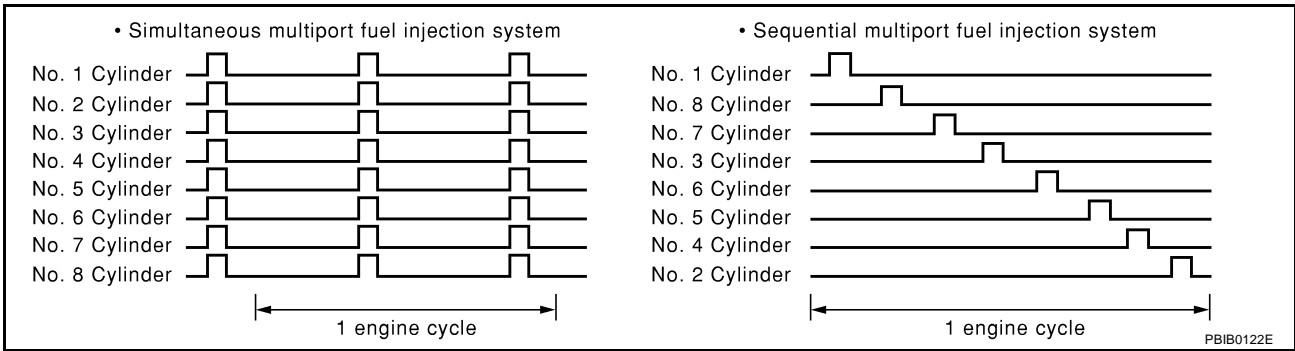

Two types of systems are used.

Sequential Multipoint Fuel Injection System

Fuel is injected into each cylinder during each engine cycle according to the firing order. This system is used when the engine is running.

Simultaneous Multipoint Fuel Injection System

Fuel is injected simultaneously into all eight cylinders twice each engine cycle. In other words, pulse signals of the same width are simultaneously transmitted from the ECM.

The eight injectors will then receive the signals two times for each engine cycle.

This system is used when the engine is being started and/or if the fail-safe system (CPU) is operating.

FUEL SHUT-OFF

Fuel to each cylinder is cut off during deceleration or operation of the engine at excessively high speeds.

Electronic Ignition (EI) System INPUT/OUTPUT SIGNAL CHART

ABS00BZ7

Sensor	Input signal to ECM	ECM function	Actuator
Crankshaft position sensor (POS)	Engine speed*2 Piston position	Ignition timing control	Power transistor
Camshaft position sensor (PHASE)			
Mass air flow sensor	Amount of intake air		
Engine coolant temperature sensor	Engine coolant temperature		
Throttle position sensor	Throttle position		
Accelerator pedal position sensor	Accelerator pedal position		
Knock sensor	Engine knocking		
Park/neutral position (PNP) switch	Gear position		
Battery	Battery voltage*2		
Wheel sensor*1	Vehicle speed		

*1: This signal is sent to the ECM through CAN communication line.

*2: ECM determines the start signal status by the signals of engine speed and battery voltage.

SYSTEM DESCRIPTION

The ignition timing is controlled by the ECM to maintain the best air-fuel ratio for every running condition of the engine. The ignition timing data is stored in the ECM. This data forms the map shown.

The ECM receives information such as the injection pulse width and camshaft position sensor signal. Computing this information, ignition signals are transmitted to the power transistor.

e.g., N: 1,800 rpm, Tp: 1.50 msec

A °BTDC

During the following conditions, the ignition timing is revised by the ECM according to the other data stored in the ECM.

- At starting
- During warm-up

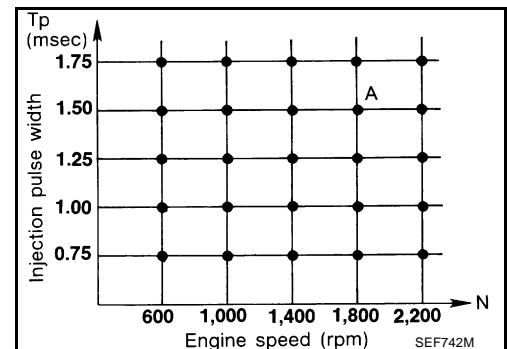

- At idle
- At low battery voltage
- During acceleration

The knock sensor retard system is designed only for emergencies. The basic ignition timing is programmed within the anti-knocking zone, if recommended fuel is used under dry conditions. The retard system does not operate under normal driving conditions. If engine knocking occurs, the knock sensor monitors the condition. The signal is transmitted to the ECM. The ECM retards the ignition timing to eliminate the knocking condition.

Nissan Torque Demand (NTD) Control System INPUT/OUTPUT SIGNAL CHART

ABS00BZ8

Sensor	Input signal to ECM	ECM function	Actuator
Camshaft position sensor (PHASE) Crankshaft position sensor (POS)	Engine speed	NTD control	Electric throttle control actuator and fuel injector
Mass air flow sensor	Amount of intake air		
Engine coolant temperature sensor	Engine coolant temperature		
Throttle position sensor	Throttle position		
Accelerator pedal position sensor	Accelerator pedal position		
Park/Neutral position (PNP) switch	Gear position		
Power steering pressure sensor	Power steering operation		
Battery	Battery voltage		
TCM (CAN communication)	A/T control signal		
Air conditioner switch*	Air conditioner operation		
ABS actuator and electric unit (control unit)*	VDC/TCS/ABS operation		
Wheel sensor*	Vehicle speed		
Electrical load*	Electrical load signal		

*: This signal is sent to the ECM through CAN communication line.

SYSTEM DESCRIPTION

NTD control system decides the target traction based on the accelerator operation status and the current driving condition. It then selects the engine torque target by correcting running resistance and atmospheric pressure, and controlling the power-train. Using electric throttle control actuator, it achieves the engine torque development target which corresponds linearly to the driver's accelerator operation.

Running resistance correction control compares the engine torque estimate value, measured vehicle acceleration, and running resistance on a flat road, and estimates vehicle weight gain and running resistance variation caused by slopes to correct the engine torque estimate value.

Atmospheric pressure correction control compares the engine torque estimate value from the airflow rate and the target engine torque for the target traction, and estimates variation of atmospheric pressure to correct the target engine torque. This system achieves powerful driving without reducing engine performance in the practical speed range in mountains and high-altitude areas.

Air Conditioning Cut Control INPUT/OUTPUT SIGNAL CHART

Sensor	Input signal to ECM	ECM function	Actuator
Air conditioner switch*1	Air conditioner ON signal	Air conditioner cut control	Air conditioner relay
Throttle position sensor	Throttle position		
Accelerator pedal position sensor	Accelerator pedal position		
Crankshaft position sensor (POS) Camshaft position sensor (PHASE)	Engine speed*2		
Engine coolant temperature sensor	Engine coolant temperature		
Battery	Battery voltage*2		
Refrigerant pressure sensor	Refrigerant pressure		
Power steering pressure sensor	Power steering operation		
Wheel sensor*1	Vehicle speed		

*1: This signal is sent to the ECM through CAN communication line.

*2: ECM determines the start signal status by the signals of engine speed and battery voltage.

SYSTEM DESCRIPTION

This system improves engine operation when the air conditioner is used. Under the following conditions, the air conditioner is turned off.

- When the accelerator pedal is fully depressed.
- When cranking the engine.
- At high engine speeds.
- When the engine coolant temperature becomes excessively high.
- When operating power steering during low engine speed or low vehicle speed.
- When engine speed is excessively low.
- When refrigerant pressure is excessively low or high.

Fuel Cut Control (at No Load and High Engine Speed) INPUT/OUTPUT SIGNAL CHART

Sensor	Input signal to ECM	ECM function	Actuator
Park/neutral position (PNP) switch	Neutral position	Fuel cut control	Fuel injector
Accelerator pedal position sensor	Accelerator pedal position		
Engine coolant temperature sensor	Engine coolant temperature		
Crankshaft position sensor (POS) Camshaft position sensor (PHASE)	Engine speed		
Wheel sensor*	Vehicle speed		

*: This signal is sent to the ECM through CAN communication line.

SYSTEM DESCRIPTION

If the engine speed is above 1,400 rpm under no load (for example, the shift position is neutral and engine speed is over 1,400 rpm) fuel will be cut off after some time. The exact time when the fuel is cut off varies based on engine speed.

Fuel cut will be operated until the engine speed reaches 1,000 rpm, then fuel cut will be cancelled.

NOTE:

This function is different from deceleration control listed under Multiport Fuel Injection (MFI) System, [EC-679](#).

CAN communication SYSTEM DESCRIPTION

CAN (Controller Area Network) is a serial communication line for real time application. It is an on-vehicle multiplex communication line with high data communication speed and excellent error detection ability. Many electronic control units are equipped onto a vehicle, and each control unit shares information and links with other control units during operation (not independent). In CAN communication, control units are connected with 2 communication lines (CAN H line, CAN L line) allowing a high rate of information transmission with less wiring. Each control unit transmits/receives data but selectively reads required data only.

Refer to [LAN-6, "CAN Communication Unit"](#) , about CAN communication for detail.

BASIC SERVICE PROCEDURE

PFP:00018

Idle Speed and Ignition Timing Check

IDLE SPEED

ABS00BZC

With CONSULT-II

Check idle speed in "DATA MONITOR" mode with CONSULT-II.

DATA MONITOR	
MONITOR	NO DTC
ENG SPEED	XXX rpm

SEF058Y

With GST

Check idle speed with GST.

IGNITION TIMING

Any of following two methods may be used.

Method A

1. Attach timing light to loop wire as shown.

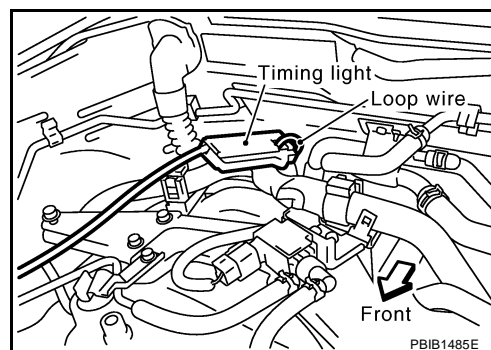

2. Check ignition timing.

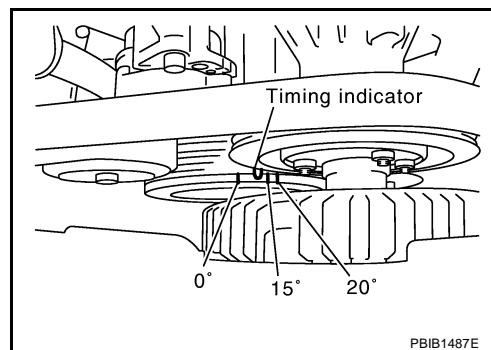

Method B

1. Remove No. 1 ignition coil.

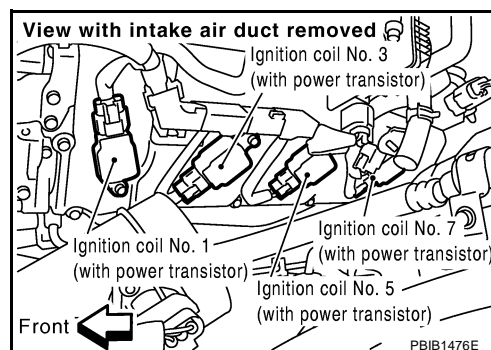

A
EC
C
D
E
F
G
H
I
J
K
L
M

BASIC SERVICE PROCEDURE

[VK45DE]

2. Connect No. 1 ignition coil and No. 1 spark plug with suitable high-tension wire as shown, and attach timing light clamp to this wire.

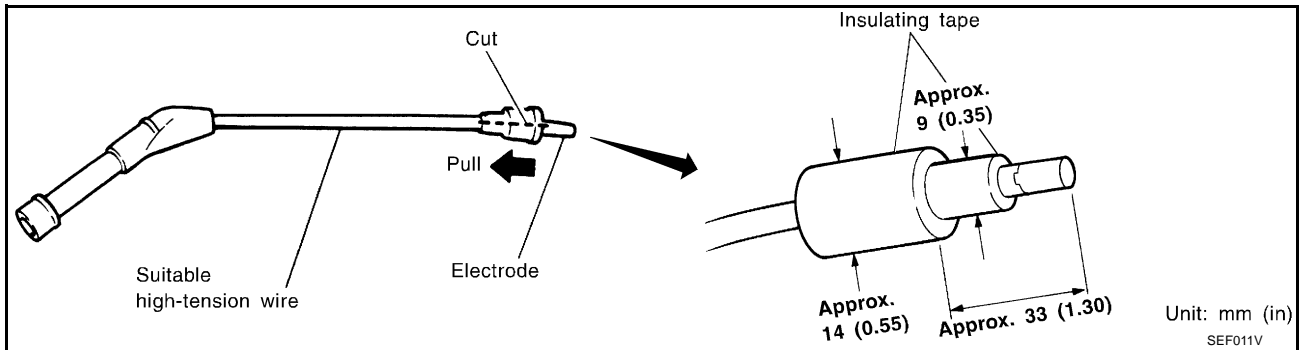
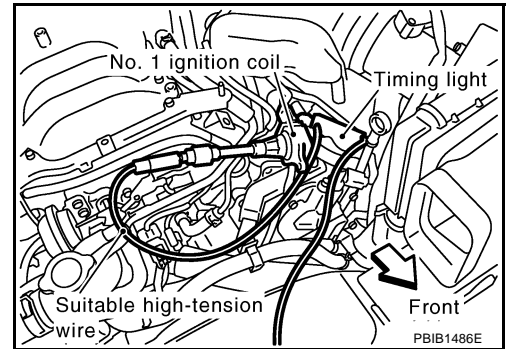

3. Check ignition timing.

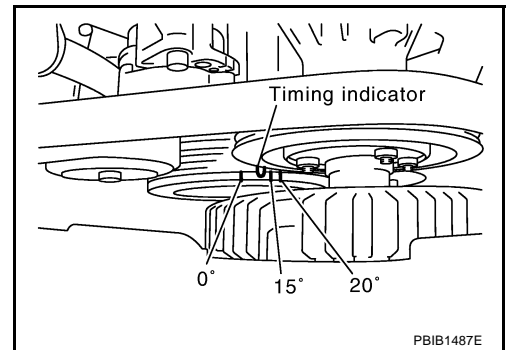

Idle Speed/Ignition Timing/Idle Mixture Ratio Adjustment

PREPARATION

- | | |
|---|--|
| <ol style="list-style-type: none"> 1. Make sure that the following parts are in good order. <ul style="list-style-type: none"> ● Battery ● Ignition system ● Engine oil and coolant levels ● Fuses ● ECM harness connector ● Vacuum hoses ● Air intake system
(Oil filler cap, oil level gauge, etc.) ● Fuel pressure ● Engine compression ● Throttle valve ● Evaporative emission system 2. On air conditioner equipped models, checks should be carried out while the air conditioner is OFF. 3. On automatic transmission equipped models, when checking idle rpm, ignition timing and mixture ratio, checks should be carried out while shift lever is in N position. 4. When measuring CO percentage, insert probe more than 40 cm (15.7 in) into tail pipe. 5. Turn OFF headlamp, heater blower, rear window defogger. 6. Keep front wheels pointed straight ahead. | <p>A</p> <p>EC</p> <p>C</p> <p>D</p> <p>E</p> <p>F</p> <p>G</p> <p>H</p> <p>I</p> <p>J</p> <p>K</p> <p>L</p> <p>M</p> |
|---|--|

OVERALL INSPECTION SEQUENCE

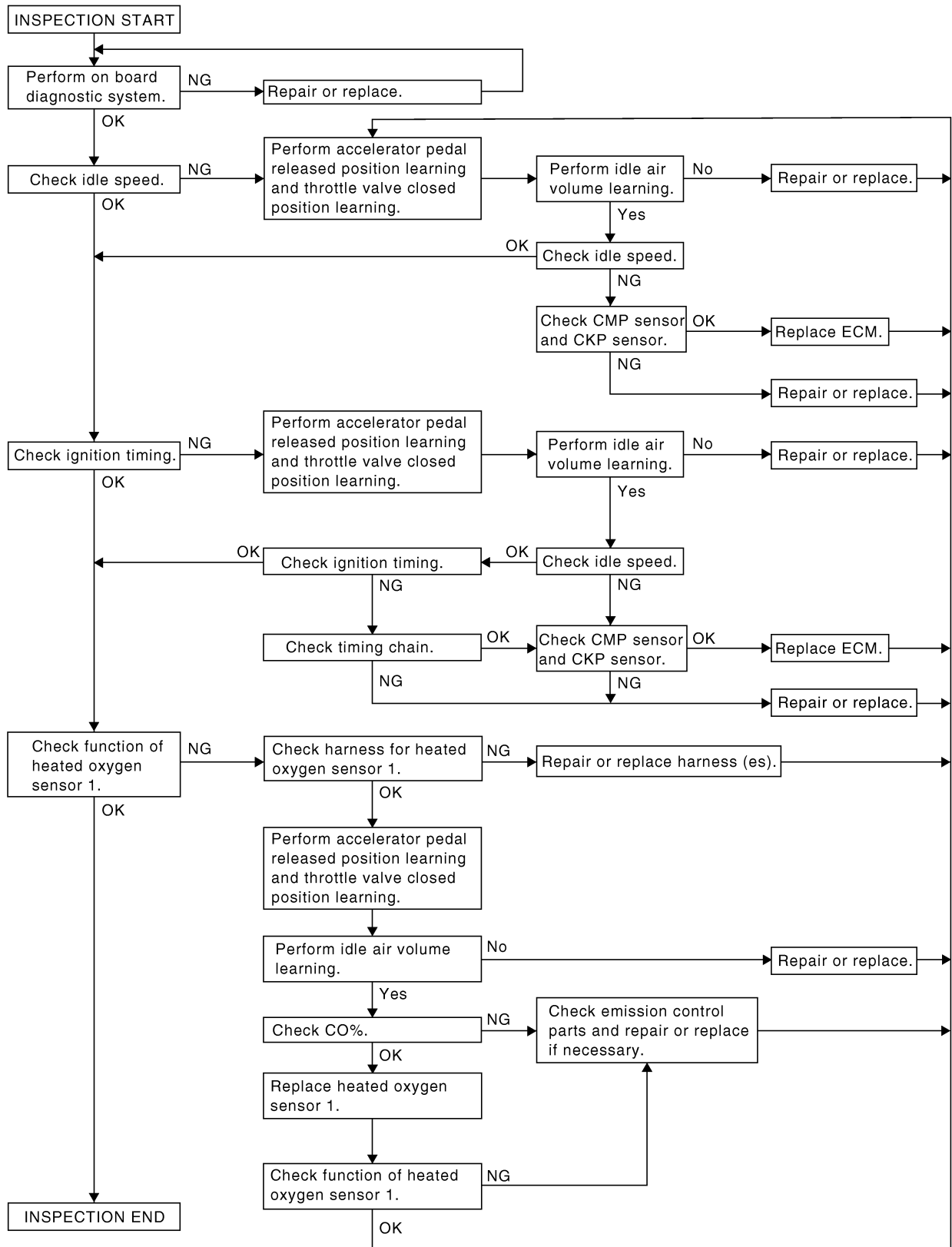

NOTE:

If a vehicle contains a part which is operating outside of design specifications with no MIL illumination, the part shall not be replaced prior to emission testing unless it is determined that the part has been tampered with or abused in such a way that the diagnostic system cannot reasonably be expected to detect the resulting malfunction.

PBIB2001E

INSPECTION PROCEDURE

1. INSPECTION START

1. Check service records for any recent repairs that may indicate a related malfunction, or a current need for scheduled maintenance.
2. Open engine hood and check the following:
 - Harness connectors for improper connections
 - Wiring harness for improper connections, pinches and cut
 - Vacuum hoses for splits, kinks and improper connections
 - Hoses and ducts for leaks
 - Air cleaner clogging
 - Gasket
3. Confirm that electrical or mechanical loads are not applied.
 - Headlamp switch is OFF.
 - Air conditioner switch is OFF.
 - Rear window defogger switch is OFF.
 - Steering wheel is in the straight-ahead position, etc.
4. Start engine and warm it up until engine coolant temperature indicator points the middle of gauge. Ensure engine stays below 1,000 rpm.

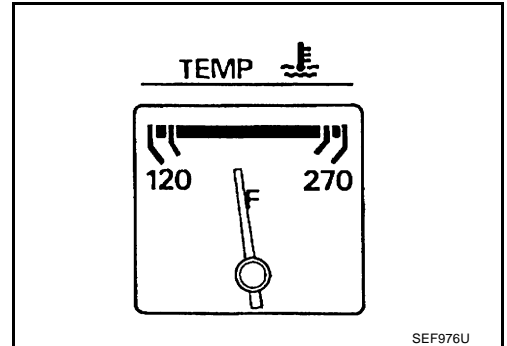
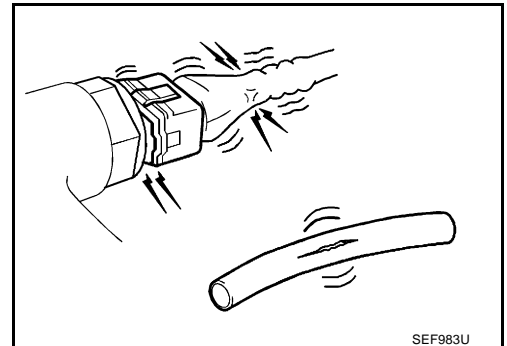

5. Run engine at about 2,000 rpm for about 2 minutes under no load.
6. Make sure that no DTC is displayed with CONSULT-II or GST.

OK or NG

- OK >> GO TO 3.
 NG >> GO TO 2.

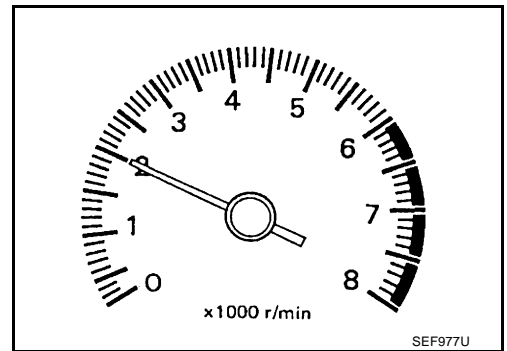

2. REPAIR OR REPLACE

Repair or replace components as necessary according to corresponding Diagnostic Procedure.

>> GO TO 3.

A
EC
C
D
E
F
G
H
I
J
K
L
M

3. CHECK TARGET IDLE SPEED

 **With CONSULT-II**

1. Run engine at about 2,000 rpm for about 2 minutes under no load.
2. Rev engine (2,000 to 3,000 rpm) two or three times under no load, then run engine at idle speed for about 1 minute.

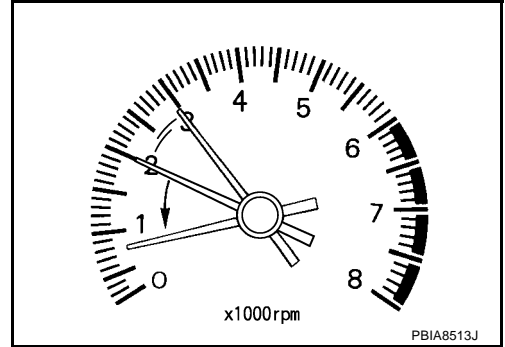

3. Read idle speed in "DATA MONITOR" mode with CONSULT-II.
650 ± 50 rpm (in P or N position)

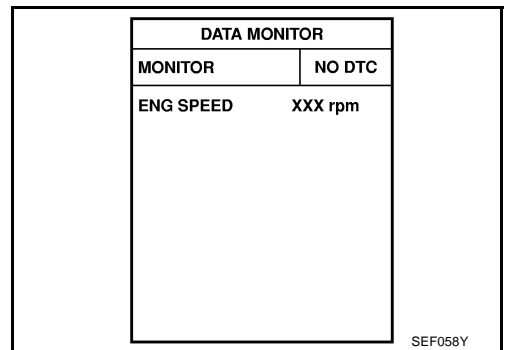

 **Without CONSULT-II**

1. Run engine at about 2,000 rpm for about 2 minutes under no load.
2. Rev engine (2,000 to 3,000 rpm) two or three times under no load, then run engine at idle speed for about 1 minute.
3. Check idle speed.

650 ± 50 rpm (in P or N position)

OK or NG

- OK >> GO TO 10.
NG >> GO TO 4.

4. PERFORM ACCELERATOR PEDAL RELEASED POSITION LEARNING

1. Stop engine.
2. Perform [EC-698, "Accelerator Pedal Released Position Learning"](#) .

>> GO TO 5.

5. PERFORM THROTTLE VALVE CLOSED POSITION LEARNING

Perform [EC-698, "Throttle Valve Closed Position Learning"](#) .

>> GO TO 6.

6. PERFORM IDLE AIR VOLUME LEARNING

Perform [EC-698, "Idle Air Volume Learning"](#) .

Is Idle Air Volume Learning carried out successfully?

Yes or No

- Yes >> GO TO 7.
 No >> 1. Follow the instruction of Idle Air Volume Learning.
 2. GO TO 4.

7. CHECK TARGET IDLE SPEED AGAIN

With CONSULT-II

1. Start engine and warm it up to normal operating temperature.
2. Read idle speed in "DATA MONITOR" mode with CONSULT-II.

650 ± 50 rpm (in P or N position)

Without CONSULT-II

1. Start engine and warm it up to normal operating temperature.
2. Check idle speed.

650 ± 50 rpm (in P or N position)

OK or NG

- OK >> GO TO 10.
 NG >> GO TO 8.

DATA MONITOR	
MONITOR	NO DTC
ENG SPEED	XXX rpm

SEP058Y

8. DETECT MALFUNCTIONING PART

Check the following.

- Check camshaft position sensor (PHASE) and circuit. Refer to [EC-966](#) .
- Check crankshaft position sensor (POS) and circuit. Refer to [EC-960](#) .

OK or NG

- OK >> GO TO 9.
 NG >> 1. Repair or replace.
 2. GO TO 4.

9. CHECK ECM FUNCTION

1. Substitute another known-good ECM to check ECM function. (ECM may be the cause of an incident, but this is a rare case.)
2. Perform initialization of IVIS (NATS) system and registration of all IVIS (NATS) ignition key IDs. Refer to [BL-208, "ECM Re-communicating Function"](#) .

>> GO TO 4.

10. CHECK IGNITION TIMING

1. Run engine at idle.
2. Check ignition timing with a timing light.

12 ± 5° BTDC (in P or N position)

OK or NG

- OK (With CONSULT-II) >> GO TO 19.
 OK (Without CONSULT-II) >> GO TO 20.
 NG >> GO TO 11.

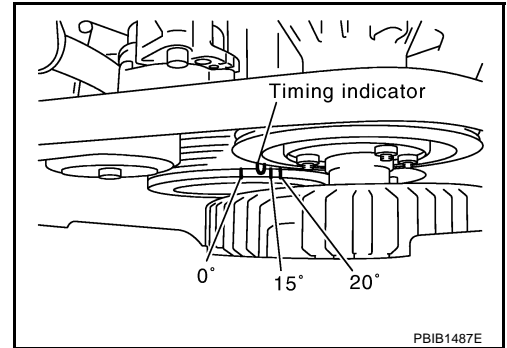

11. PERFORM ACCELERATOR PEDAL RELEASED POSITION LEARNING

1. Stop engine.
2. Perform [EC-698, "Accelerator Pedal Released Position Learning"](#) .

>> GO TO 12.

12. PERFORM THROTTLE VALVE CLOSED POSITION LEARNING

Perform [EC-698, "Throttle Valve Closed Position Learning"](#) .

>> GO TO 13.

13. PERFORM IDLE AIR VOLUME LEARNING

Perform [EC-698, "Idle Air Volume Learning"](#) .

Is Idle Air Volume Learning carried out successfully?

Yes or No

- Yes >> GO TO 14.
 No >> 1. Follow the instruction of Idle Air Volume Learning.
 2. GO TO 4.

14. CHECK TARGET IDLE SPEED AGAIN

With CONSULT-II

1. Start engine and warm it up to normal operating temperature.
2. Read idle speed in "DATA MONITOR" mode with CONSULT-II.

650 ± 50 rpm (in P or N position)

Without CONSULT-II

1. Start engine and warm it up to normal operating temperature.
2. Check idle speed.

650 ± 50 rpm (in P or N position)

OK or NG

- OK >> GO TO 15.
 NG >> GO TO 17.

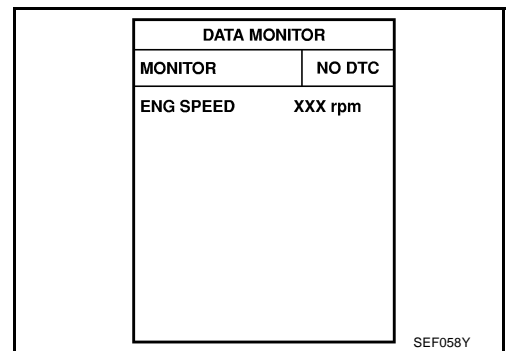

15. CHECK IGNITION TIMING AGAIN

1. Run engine at idle.
2. Check ignition timing with a timing light.

12 ± 5° BTDC (in P or N position)

OK or NG

- OK (With CONSULT-II)>>GO TO 19.
 OK (Without CONSULT-II)>>GO TO 20.
 NG >> GO TO 16.

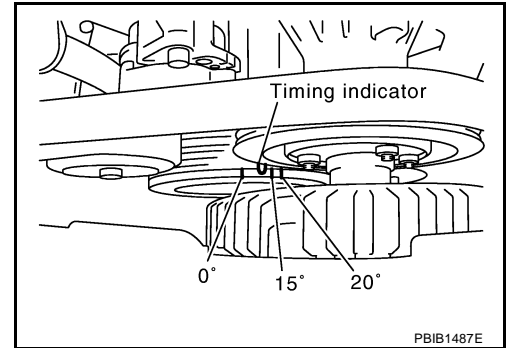

16. CHECK TIMING CHAIN INSTALLATION

Check timing chain installation. Refer to [EM-196, "TIMING CHAIN"](#) .

OK or NG

- OK >> GO TO 17.
 NG >> 1. Repair the timing chain installation.
 2. GO TO 4.

17. DETECT MALFUNCTIONING PART

Check the following.

- Check camshaft position sensor (PHASE) and circuit. Refer to [EC-966](#) .
- Check crankshaft position sensor (POS) and circuit. Refer to [EC-960](#) .

OK or NG

- OK >> GO TO 18.
 NG >> 1. Repair or replace.
 2. GO TO 4.

18. CHECK ECM FUNCTION

1. Substitute another known-good ECM to check ECM function. (ECM may be the cause of an incident, but this is a rare case.)
2. Perform initialization of IVIS (NATS) system and registration of all IVIS (NATS) ignition key IDs. Refer to [BL-208, "ECM Re-communicating Function"](#) .

>> GO TO 4.

19. CHECK HEATED OXYGEN SENSOR 1 (BANK 1) SIGNAL

With CONSULT-II

1. Run engine at about 2,000 rpm for about 2 minutes under no load.
2. See "HO2S1 MNTR (B1)" in "DATA MONITOR" mode.
3. Running engine at 2,000 rpm under no load (The engine is warmed up to normal operating temperature.), check that the monitor fluctuates between LEAN and RICH more than 5 times during 10 seconds.

1 time: RICH → LEAN → RICH

2 times: RICH → LEAN → RICH → LEAN → RICH

DATA MONITOR	
MONITOR	NO DTC
ENG SPEED	XXX rpm
HO2S1 MNTR (B1)	LEAN
HO2S1 MNTR (B2)	RICH

PBIB0120E

OK or NG

OK >> GO TO 21.

NG (Monitor does not fluctuate.)>>GO TO 23.

NG (Monitor fluctuates less than 5 times.)>>GO TO 31.

20. CHECK HEATED OXYGEN SENSOR 1 (BANK 1) SIGNAL

Without CONSULT-II

1. Stop engine and set ECM to Self-diagnostic mode II (Heated oxygen sensor 1 monitor). Refer to [EC-719, "HOW TO SWITCH DIAGNOSTIC TEST MODE"](#).
2. Start engine and run it at about 2,000 rpm for about 2 minutes under no load.
3. Running engine at 2,000 rpm under no load (The engine is warmed up to normal operating temperature.), check that the MIL comes on more than 5 times during 10 seconds.

OK or NG

OK >> GO TO 22.

NG (MIL does not come on)>>GO TO 23.

NG (MIL comes on less than 5 times)>>GO TO 31.

21. CHECK HEATED OXYGEN SENSOR 1 (BANK 2) SIGNAL

With CONSULT-II

1. See "HO2S1 MNTR (B2)" in "DATA MONITOR" mode.
2. Running engine at 2,000 rpm under no load (The engine is warmed up to normal operating temperature.), check that the monitor fluctuates between LEAN and RICH more than 5 times during 10 seconds.

1 time: RICH → LEAN → RICH

2 times: RICH → LEAN → RICH → LEAN → RICH

DATA MONITOR	
MONITOR	NO DTC
ENG SPEED	XXX rpm
HO2S1 MNTR (B1)	LEAN
HO2S1 MNTR (B2)	RICH

PBIB0120E

OK or NG

OK >> **INSPECTION END**

NG (Monitor does not fluctuate.)>>GO TO 24.

NG (Monitor fluctuates less than 5 times.)>>GO TO 31.

22. CHECK HEATED OXYGEN SENSOR 1 (BANK 2) SIGNAL

⊗ Without CONSULT-II

1. Switch the monitored sensor from bank 1 to bank 2. Refer to [EC-719, "How to Switch Monitored Sensor From Bank 1 to Bank 2 or Vice Versa"](#) .
2. Running engine at 2,000 rpm under no load (The engine is warmed up to normal operating temperature.), check that the MIL comes on more than 5 times during 10 seconds.

OK or NG

OK >> **INSPECTION END**

NG (MIL does not come on)>>GO TO 24.

NG (MIL comes on less than 5 times)>>GO TO 31.

23. CHECK HEATED OXYGEN SENSOR 1 (BANK 1) HARNESS

1. Turn ignition switch OFF and disconnect battery ground cable.
2. Disconnect ECM harness connector.
3. Disconnect heated oxygen sensor 1 (bank 1) harness connector.
4. Check harness continuity between ECM terminal 16 and heated oxygen sensor 1 (bank 1) terminal 1. Refer to Wiring Diagram, [EC-865, "BANK 1"](#) .

Continuity should exist.

5. Also check harness for short to ground and short to power.

OK or NG

OK >> GO TO 25.

NG >> 1. Repair or replace harness between ECM and heated oxygen sensor 1 (bank 1).
2. GO TO 4.

24. CHECK HEATED OXYGEN SENSOR 1 (BANK 2) HARNESS

1. Turn ignition switch OFF and disconnect battery ground cable.
2. Disconnect ECM harness connector.
3. Disconnect heated oxygen sensor 1 (bank 2) harness connector.
4. Check harness continuity between ECM terminal 35 and heated oxygen sensor 1 (bank 2) terminal 1. Refer to Wiring Diagram, [EC-867, "BANK 2"](#) .

Continuity should exist.

5. Also check harness for short to ground and short to power.

OK or NG

OK >> GO TO 25.

NG >> 1. Repair or replace harness between ECM and heated oxygen sensor 1 (bank 2).
2. GO TO 4.

25. PERFORM ACCELERATOR PEDAL RELEASED POSITION LEARNING

1. Reconnect ECM harness connector.
2. Reconnect heated oxygen sensor 1 harness connector.
3. Perform [EC-698, "Accelerator Pedal Released Position Learning"](#) .

>> GO TO 26.

26. PERFORM THROTTLE VALVE CLOSED POSITION LEARNING

Perform [EC-698, "Throttle Valve Closed Position Learning"](#) .

>> GO TO 27.

27. PERFORM IDLE AIR VOLUME LEARNING

Refer to [EC-698, "Idle Air Volume Learning"](#) .

Is Idle Air Volume Learning carried out successfully?

Yes or No

Yes (With CONSULT-II)>>GO TO 28.

Yes (Without CONSULT-II)>>GO TO 29.

No >> 1. Follow the instruction of Idle Air Volume Learning.
2. GO TO 4.

28. CHECK CO%

 With CONSULT-II

1. Start engine and warm it up until engine coolant temperature indicator points the middle of gauge.
2. Turn ignition switch OFF, wait at least 10 seconds and then turn ON.
3. Select "ENG COOLANT TEMP" in "ACTIVE TEST" mode.
4. Set "ENG COOLANT TEMP" to 5°C (41°F) by touching "DWN" and "Qd".
5. Start engine and rev it (2,000 to 3,000 rpm) two or three times under no load, then run engine at idle speed.
6. Check CO%.

Idle CO: 0.7 – 9.9% and engine runs smoothly.

OK or NG

OK >> GO TO 31.

NG >> GO TO 30.

ACTIVE TEST	
ENG COOLANT TEMP	XXX °C
MONITOR	
ENG SPEED	XXX rpm
INJ PULSE-B1	XXX msec
IGN TIMING	XXX BTDC

SEF172Y

29. CHECK CO%

 Without CONSULT-II

1. Start engine and warm it up until engine coolant temperature indicator points to the middle of gauge.
2. Turn ignition switch OFF.
3. Disconnect engine coolant temperature sensor harness connector.
4. Connect a resistor (4.4 kΩ) between terminals of engine coolant temperature sensor harness connector.
5. Start engine and rev it (2,000 to 3,000 rpm) two or three times under no load, then run engine at idle speed.
6. Check CO%.

Idle CO: 0.7 – 9.9% and engine runs smoothly.

7. After checking CO%, turn ignition switch OFF, disconnect the resistor from the terminals of engine coolant temperature sensor harness connector, and then connect engine coolant temperature sensor harness connector to engine coolant temperature sensor.

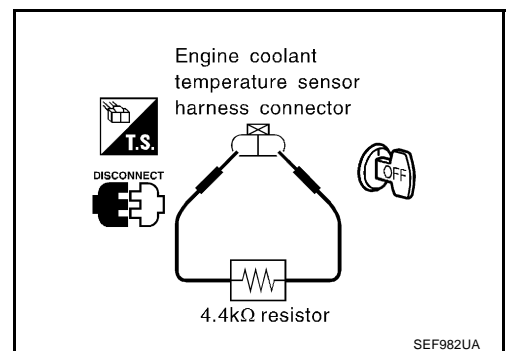

OK or NG

OK >> GO TO 31.

NG >> GO TO 30.

30. RECONNECT HEATED OXYGEN SENSOR 1 HARNESS CONNECTOR

1. Turn ignition switch OFF.
2. Reconnect heated oxygen sensor 1 harness connector.

>> GO TO 34.

31. REPLACE HEATED OXYGEN SENSOR 1

1. Stop engine.
2. Replace heated oxygen sensor 1 on the malfunctioning bank.

With CONSULT-II>>GO TO 32.
Without CONSULT-II>>GO TO 33.

32. CHECK HEATED OXYGEN SENSOR 1 (BANK 1)/(BANK 2) SIGNAL

Ⓟ With CONSULT-II

1. Start engine and warm it up until engine coolant temperature indicator points the middle of gauge.
2. See "HO2S1 MNTR (B1)/(B2)" in "DATA MONITOR" mode.
3. Running engine at 2,000 rpm under no load (The engine is warmed up to normal operating temperature.), check that the monitor fluctuates between LEAN and RICH more than 5 times during 10 seconds.

1 time: RICH → LEAN → RICH

2 times: RICH → LEAN → RICH → LEAN → RICH

DATA MONITOR	
MONITOR	NO DTC
ENG SPEED	XXX rpm
HO2S1 MNTR (B1)	LEAN
HO2S1 MNTR (B2)	RICH

PBIB0120E

OK or NG

- OK >> GO TO 4.
NG >> GO TO 34.

33. CHECK HEATED OXYGEN SENSOR 1 (BANK 1)/(BANK 2) SIGNAL

ⓧ Without CONSULT-II

1. Set ECM to Self-diagnostic mode II (Heated oxygen sensor 1 monitor). Refer to [EC-719, "HOW TO SWITCH DIAGNOSTIC TEST MODE"](#) .
2. Switch the monitored sensor to the malfunctioning bank. Refer to [EC-719, "How to Switch Monitored Sensor From Bank 1 to Bank 2 or Vice Versa"](#) .
3. Running engine at 2,000 rpm under no load (The engine is warmed up to normal operating temperature.), check that the MIL comes on more than 5 times during 10 seconds.

OK or NG

- OK >> GO TO 4.
NG >> GO TO 34.

34. DETECT MALFUNCTIONING PART

Check the following.

- Check fuel pressure regulator and repair or replace if necessary. Refer to [EC-700, "Fuel Pressure Check"](#) .
- Check mass air flow sensor and its circuit, and repair or replace if necessary. Refer to [EC-822](#) , [EC-830](#) , [EC-1064](#) .
- Check injector and its circuit, and repair or replace if necessary. Refer to [EC-1274](#) .
- Check engine coolant temperature sensor and its circuit, and repair or replace if necessary. Refer to [EC-842](#) and [EC-855](#) .

OK or NG

- OK >> GO TO 36.
NG >> 1. Repair or replace.
2. GO TO 35.

35. ERASE UNNECESSARY DTC

After this inspection, unnecessary DTC might be displayed.

Erase the stored memory in ECM and TCM. Refer to [EC-715, "HOW TO ERASE EMISSION-RELATED DIAGNOSTIC INFORMATION"](#) and [AT-39, "HOW TO ERASE DTC"](#) .

>> GO TO 4.

36. CHECK ECM FUNCTION

1. Substitute another known-good ECM to check ECM function. (ECM may be the cause of an incident, but this is a rare case.)
2. Perform initialization of IVIS (NATS) system and registration of all IVIS (NATS) ignition key IDs. Refer to [BL-208, "ECM Re-communicating Function"](#) .

>> GO TO 4.

Accelerator Pedal Released Position Learning DESCRIPTION

ABS00BZE

Accelerator Pedal Released Position Learning is an operation to learn the fully released position of the accelerator pedal by monitoring the accelerator pedal position sensor output signal. It must be performed each time harness connector of accelerator pedal position sensor or ECM is disconnected.

OPERATION PROCEDURE

1. Make sure that accelerator pedal is fully released.
2. Turn ignition switch ON and wait at least 2 seconds.
3. Turn ignition switch OFF wait at least 10 seconds.
4. Turn ignition switch ON and wait at least 2 seconds.
5. Turn ignition switch OFF wait at least 10 seconds.

Throttle Valve Closed Position Learning DESCRIPTION

ABS00BZF

Throttle Valve Closed Position Learning is an operation to learn the fully closed position of the throttle valve by monitoring the throttle position sensor output signal. It must be performed each time harness connector of electric throttle control actuator or ECM is disconnected.

OPERATION PROCEDURE

1. Make sure that accelerator pedal is fully released.
2. Turn ignition switch ON.
3. Turn ignition switch OFF wait at least 10 seconds.
Make sure that throttle valve moves during above 10 seconds by confirming the operating sound.

Idle Air Volume Learning DESCRIPTION

ABS00BZG

Idle Air Volume Learning is an operation to learn the idle air volume that keeps each engine within the specific range. It must be performed under any of the following conditions:

- Each time electric throttle control actuator or ECM is replaced.
- Idle speed or ignition timing is out of specification.

PREPARATION

Before performing Idle Air Volume Learning, make sure that all of the following conditions are satisfied. Learning will be cancelled if any of the following conditions are missed for even a moment.

- Battery voltage: More than 12.9V (At idle)
- Engine coolant temperature: 70 - 100°C (158 - 212°F)
- PNP switch: ON
- Electric load switch: OFF
(Air conditioner, headlamp, rear window defogger)

On vehicles equipped with daytime light systems, if the parking brake is applied before the engine is started, the headlamp will not be illuminated.

- Steering wheel: Neutral (Straight-ahead position)
- Vehicle speed: Stopped
- Transmission: Warmed-up
 For models with CONSULT-II, drive vehicle until "FLUID TEMP SE" in "DATA MONITOR" mode of "A/T" system indicates less than 0.9V.
 For models without CONSULT-II, drive vehicle for 10 minutes.

OPERATION PROCEDURE

④ With CONSULT-II

1. Perform [EC-698, "Accelerator Pedal Released Position Learning"](#) .
2. Perform [EC-698, "Throttle Valve Closed Position Learning"](#) .
3. Start engine and warm it up to normal operating temperature.
4. Check that all items listed under the topic PREPARATION (previously mentioned) are in good order.
5. Select "IDLE AIR VOL LEARN" in "WORK SUPPORT" mode.

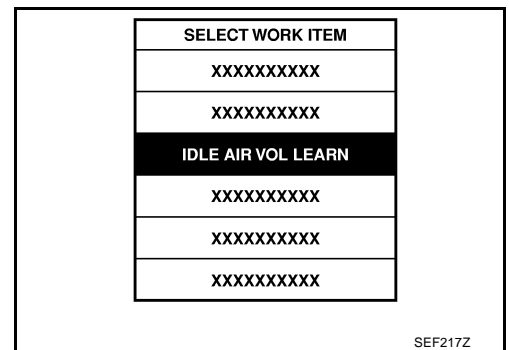

6. Touch "START" and wait 20 seconds.

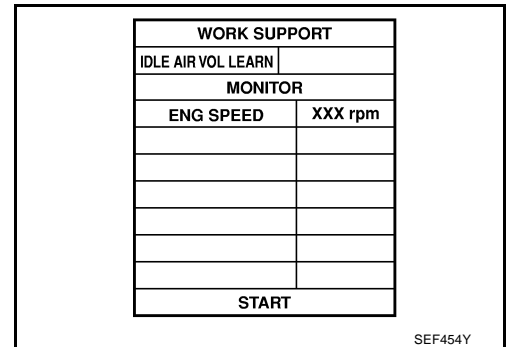

7. Make sure that "CMPLT" is displayed on CONSULT-II screen. If "CMPLT" is not displayed, Idle Air Volume Learning will not be carried out successfully. In this case, find the cause of the incident by referring to the Diagnostic Procedure below.
8. Rev up the engine two or three times and make sure that idle speed and ignition timing are within the specifications.

ITEM	SPECIFICATION
Idle speed	650 ± 50 rpm (in P or N position)
Ignition timing	12 ± 5° BTDC (in P or N position)

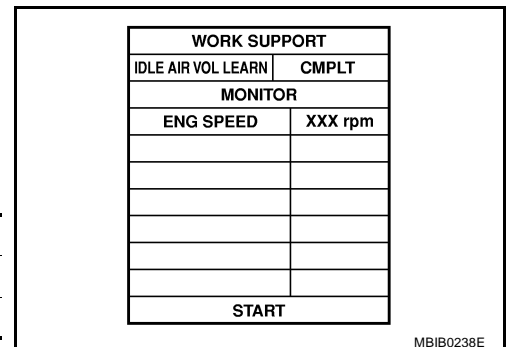

⊗ Without CONSULT-II

NOTE:

- It is better to count the time accurately with a clock.
 - It is impossible to switch the diagnostic mode when an accelerator pedal position sensor circuit has a malfunction.
1. Perform [EC-698, "Accelerator Pedal Released Position Learning"](#) .

2. Perform [EC-698, "Throttle Valve Closed Position Learning"](#) .
3. Start engine and warm it up to normal operating temperature.
4. Check that all items listed under the topic PREPARATION (previously mentioned) are in good order.
5. Turn ignition switch OFF and wait at least 10 seconds.
6. Confirm that accelerator pedal is fully released, turn ignition switch ON and wait 3 seconds.
7. Repeat the following procedure quickly five times within 5 seconds.
 - a. Fully depress the accelerator pedal.
 - b. Fully release the accelerator pedal.
8. Wait 7 seconds, fully depress the accelerator pedal and keep it for approx. 20 seconds until the MIL stops blinking and turned ON.
9. Fully release the accelerator pedal within 3 seconds after the MIL turned ON.
10. Start engine and let it idle.
11. Wait 20 seconds.

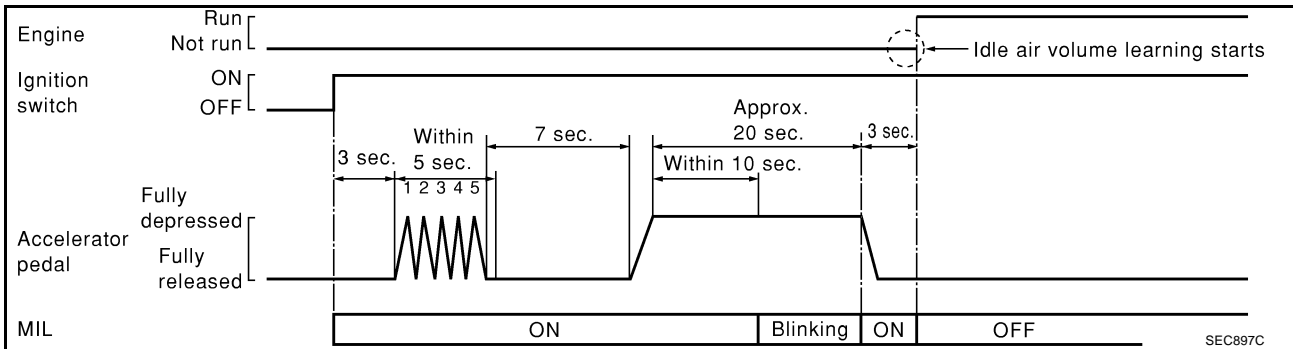

12. Rev up the engine two or three times and make sure that idle speed and ignition timing are within the specifications.

ITEM	SPECIFICATION
Idle speed	650 ± 50 rpm (in P or N position)
Ignition timing	12 ± 5° BTDC (in P or N position)

13. If idle speed and ignition timing are not within the specification, Idle Air Volume Learning will not be carried out successfully. In this case, find the cause of the incident by referring to the "DIAGNOSTIC PROCEDURE" below.

DIAGNOSTIC PROCEDURE

If idle air volume learning cannot be performed successfully, proceed as follows:

1. Check that throttle valve is fully closed.
2. Check PCV valve operation.
3. Check that downstream of throttle valve is free from air leakage.
4. When the above three items check out OK, engine component parts and their installation condition are questionable. Check and eliminate the cause of the incident.
It is useful to perform [EC-780, "TROUBLE DIAGNOSIS - SPECIFICATION VALUE"](#) .
5. If any of the following conditions occur after the engine has started, eliminate the cause of the incident and perform Idle Air Volume Learning all over again:
 - Engine stalls.
 - Erroneous idle.

Fuel Pressure Check FUEL PRESSURE RELEASE

ABS00BZH

④ With CONSULT-II

1. Turn ignition switch ON.

2. Perform "FUEL PRESSURE RELEASE" in "WORK SUPPORT" mode with CONSULT-II.
3. Start engine.
4. After engine stalls, crank it two or three times to release all fuel pressure.
5. Turn ignition switch OFF.

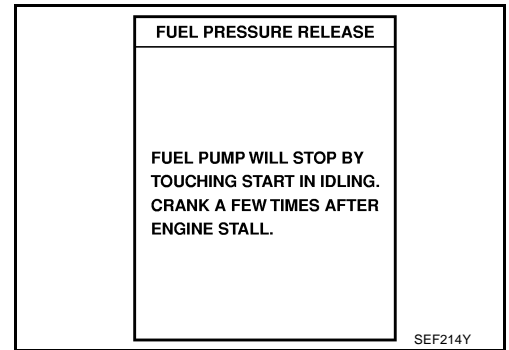

⊗ Without CONSULT-II

1. Remove fuel pump fuse located in IPDM E/R.
2. Start engine.
3. After engine stalls, crank it 2 or 3 times to release all fuel pressure.
4. Turn ignition switch OFF.
5. Reinstall fuel pump fuse after servicing fuel system.

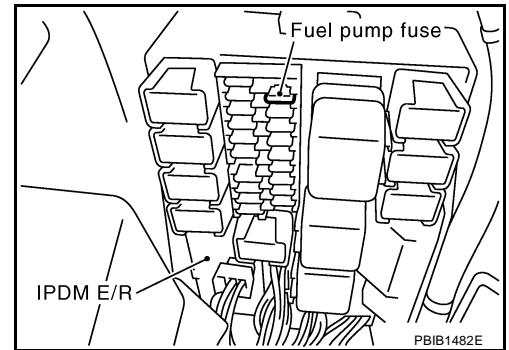

FUEL PRESSURE CHECK

Before disconnecting fuel line, release fuel pressure from fuel line to eliminate danger.

NOTE:

- Prepare pans or saucers under the disconnected fuel line because the fuel may spill out. The fuel pressure cannot be completely released because S50 models do not have fuel return system.
- Use Fuel Pressure Gauge Kit (J-44321) to check fuel pressure.

1. Release fuel pressure to zero. Refer to [EC-700, "FUEL PRESSURE RELEASE"](#).
2. Install the inline fuel quick disconnected fitting between fuel damper and injector tube.

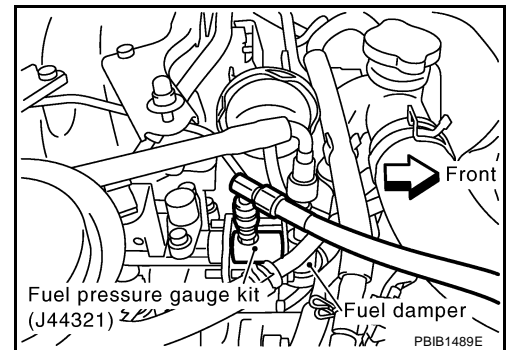

3. Connect the fuel pressure test gauge (quick connector adapter hose) to the inline fuel quick disconnected fitting.
4. Turn ignition switch ON and check for fuel leakage.
5. Start engine and check for fuel leakage.
6. Read the indication of fuel pressure gauge.

At idling: Approximately 350 kPa (3.57 kg/cm² , 51 psi)

7. If result is unsatisfactory, go to next step.
8. Check the following.
 - Fuel hoses and fuel tubes for clogging
 - Fuel filter for clogging
 - Fuel pump
 - Fuel pressure regulator for clogging

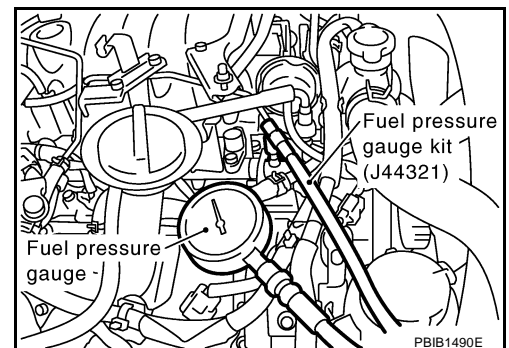

BASIC SERVICE PROCEDURE

[VK45DE]

If OK, replace fuel level sensor unit, fuel filter and fuel pump assembly.
If NG, repair or replace.

ON BOARD DIAGNOSTIC (OBD) SYSTEM

PFP:00028

Introduction

ABS00BZI

The ECM has an on board diagnostic system, which detects malfunctions related to engine sensors or actuators. The ECM also records various emission-related diagnostic information including:

Emission-related diagnostic information	SAE Mode
Diagnostic Trouble Code (DTC)	Mode 3 of SAE J1979
Freeze Frame data	Mode 2 of SAE J1979
System Readiness Test (SRT) code	Mode 1 of SAE J1979
1st Trip Diagnostic Trouble Code (1st Trip DTC)	Mode 7 of SAE J1979
1st Trip Freeze Frame data	
Test values and Test limits	Mode 6 of SAE J1979
Calibration ID	Mode 9 of SAE J1979

The above information can be checked using procedures listed in the table below.

x: Applicable —: Not applicable

	DTC	1st trip DTC	Freeze Frame data	1st trip Freeze Frame data	SRT code	Test value
CONSULT-II	x	x	x	x	x	—
GST	x	x	x	—	x	x
ECM	x	x*	—	—	—	—

*: When DTC and 1st trip DTC simultaneously appear on the display, they cannot be clearly distinguished from each other.

The malfunction indicator lamp (MIL) on the instrument panel lights up when the same malfunction is detected in two consecutive trips (Two trip detection logic), or when the ECM enters fail-safe mode. (Refer to [EC-731](#) .)

Two Trip Detection Logic

ABS00BZJ

When a malfunction is detected for the first time, 1st trip DTC and 1st trip Freeze Frame data are stored in the ECM memory. The MIL will not light up at this stage. <1st trip>

If the same malfunction is detected again during the next drive, the DTC and Freeze Frame data are stored in the ECM memory, and the MIL lights up. The MIL lights up at the same time when the DTC is stored. <2nd trip> The “trip” in the “Two Trip Detection Logic” means a driving mode in which self-diagnosis is performed during vehicle operation. Specific on board diagnostic items will cause the ECM to light up or blink the MIL, and store DTC and Freeze Frame data, even in the 1st trip, as shown below.

x: Applicable —: Not applicable

Items	MIL				DTC		1st trip DTC	
	1st trip		2nd trip		1st trip displaying	2nd trip displaying	1st trip displaying	2nd trip displaying
	Blinking	Lighting up	Blinking	Lighting up				
Misfire (Possible three way catalyst damage) — DTC: P0300 - P0308 is being detected	x	—	—	—	—	—	x	—
Misfire (Possible three way catalyst damage) — DTC: P0300 - P0308 is being detected	—	—	x	—	—	x	—	—
One trip detection diagnoses (Refer to EC-662 .)	—	x	—	—	x	—	—	—
Except above	—	—	—	x	—	x	x	—

When there is an open circuit on MIL circuit, the ECM cannot warn the driver by lighting MIL up when there is malfunction on engine control system.

Therefore, when electrical controlled throttle and part of ECM related diagnoses are continuously detected as NG for 5 trips, ECM warns the driver that engine control system malfunctions and MIL circuit is open by means of operating fail-safe function.

ON BOARD DIAGNOSTIC (OBD) SYSTEM

[VK45DE]

The fail-safe function also operates when above diagnoses except MIL circuit are detected and demands the driver to repair the malfunction.

Engine operating condition in fail-safe mode

Engine speed will not rise more than 2,500 rpm due to the fuel cut

Emission-related Diagnostic Information EMISSION-RELATED DIAGNOSTIC INFORMATION ITEMS

ABS00BZK

×: Applicable —: Not applicable

Items (CONSULT-II screen terms)	DTC*1		SRT code	Test value/ Test limit (GST only)	1st trip DTC	Reference page
	CONSULT-II GST*2	ECM*3				
CAN COMM CIRCUIT	U1000	1000*4	—	—	—	EC-792
CAN COMM CIRCUIT	U1001	1001*4	—	—	×	EC-792
NO DTC IS DETECTED. FURTHER TESTING MAY BE REQUIRED.	P0000	0000	—	—	—	—
INT/V TIM CONT-B1	P0011	0011	—	—	×	EC-795
INT/V TIM CONT-B2	P0021	0021	—	—	×	EC-795
HO2S1 HTR (B1)	P0031	0031	×	×	×	EC-806
HO2S1 HTR (B1)	P0032	0032	×	×	×	EC-806
HO2S2 HTR (B1)	P0037	0037	×	×	×	EC-814
HO2S2 HTR (B1)	P0038	0038	×	×	×	EC-814
HO2S1 HTR (B2)	P0051	0051	×	×	×	EC-806
HO2S1 HTR (B2)	P0052	0052	×	×	×	EC-806
HO2S2 HTR (B2)	P0057	0057	×	×	×	EC-814
HO2S2 HTR (B2)	P0058	0058	×	×	×	EC-814
MAF SEN/CIRCUIT	P0101	0101	—	—	—	EC-822
MAF SEN/CIRCUIT	P0102	0102	—	—	—	EC-830
MAF SEN/CIRCUIT	P0103	0103	—	—	—	EC-830
IAT SEN/CIRCUIT	P0112	0112	—	—	×	EC-837
IAT SEN/CIRCUIT	P0113	0113	—	—	×	EC-837
ECT SEN/CIRCUIT	P0117	0117	—	—	—	EC-842
ECT SEN/CIRCUIT	P0118	0118	—	—	—	EC-842
TP SEN 2/CIRC	P0122	0122	—	—	—	EC-848
TP SEN 2/CIRC	P0123	0123	—	—	—	EC-848
ECT SENSOR	P0125	0125	—	—	—	EC-855
IAT SENSOR	P0127	0127	—	—	×	EC-858
THERMSTAT FNCTN	P0128	0128	—	—	×	EC-861
HO2S1 (B1)	P0132	0132	—	×	×	EC-863
HO2S1 (B1)	P0133	0133	×	×	×	EC-872
HO2S1 (B1)	P0134	0134	—	×	×	EC-884
HO2S2 (B1)	P0138	0138	—	×	×	EC-894
HO2S2 (B1)	P0139	0139	×	×	×	EC-903
HO2S1 (B2)	P0152	0152	—	×	×	EC-863
HO2S1 (B2)	P0153	0153	×	×	×	EC-872
HO2S1 (B2)	P0154	0154	—	×	×	EC-884
HO2S2 (B2)	P0158	0158	—	×	×	EC-894
HO2S2 (B2)	P0159	0159	×	×	×	EC-903

ON BOARD DIAGNOSTIC (OBD) SYSTEM

[VK45DE]

Items (CONSULT-II screen terms)	DTC*1		SRT code	Test value/ Test limit (GST only)	1st trip DTC	Reference page
	CONSULT-II GST*2	ECM*3				
FUEL SYS-LEAN-B1	P0171	0171	—	—	×	EC-914
FUEL SYS-RICH-B1	P0172	0172	—	—	×	EC-923
FUEL SYS-LEAN-B2	P0174	0174	—	—	×	EC-914
FUEL SYS-RICH-B2	P0175	0175	—	—	×	EC-923
FTT SENSOR	P0181	0181	—	—	×	EC-931
FTT SEN/CIRCUIT	P0182	0182	—	—	×	EC-937
FTT SEN/CIRCUIT	P0183	0183	—	—	×	EC-937
TP SEN 1/CIRC	P0222	0222	—	—	—	EC-942
TP SEN 1/CIRC	P0223	0223	—	—	—	EC-942
MULTI CYL MISFIRE	P0300	0300	—	—	×	EC-949
CYL 1 MISFIRE	P0301	0301	—	—	×	EC-949
CYL 2 MISFIRE	P0302	0302	—	—	×	EC-949
CYL 3 MISFIRE	P0303	0303	—	—	×	EC-949
CYL 4 MISFIRE	P0304	0304	—	—	×	EC-949
CYL 5 MISFIRE	P0305	0305	—	—	×	EC-949
CYL 6 MISFIRE	P0306	0306	—	—	×	EC-949
CYL 7 MISFIRE	P0307	0307	—	—	×	EC-949
CYL 8 MISFIRE	P0308	0308	—	—	×	EC-949
KNOCK SEN/CIRC-B1	P0327	0327	—	—	×	EC-955
KNOCK SEN/CIRC-B1	P0328	0328	—	—	×	EC-955
KNOCK SEN/CIRC-B2	P0332	0332	—	—	×	EC-955
KNOCK SEN/CIRC-B2	P0333	0333	—	—	×	EC-955
CKP SEN/CIRCUIT	P0335	0335	—	—	×	EC-960
CMP SEN/CIRC-B1	P0340	0340	—	—	×	EC-966
TW CATALYST SYS-B1	P0420	0420	×	×	×	EC-971
TW CATALYST SYS-B2	P0430	0430	×	×	×	EC-971
EVAP PURG FLOW/MON	P0441	0441	×	×	×	EC-976
EVAP SMALL LEAK	P0442	0442	×	×	×	EC-981
PURG VOLUME CONT/V	P0444	0444	—	—	×	EC-990
PURG VOLUME CONT/V	P0445	0445	—	—	×	EC-990
VENT CONTROL VALVE	P0447	0447	—	—	×	EC-997
EVAP SYS PRES SEN	P0451	0451	—	—	×	EC-1004
EVAP SYS PRES SEN	P0452	0452	—	—	×	EC-1007
EVAP SYS PRES SEN	P0453	0453	—	—	×	EC-1014
EVAP GROSS LEAK	P0455	0455	—	×	×	EC-1022
EVAP VERY SML LEAK	P0456	0456	×*5	×	×	EC-1030
FUEL LEV SEN SLOSH	P0460	0460	—	—	×	EC-1040
FUEL LEVEL SENSOR	P0461	0461	—	—	×	EC-1042
FUEL LEVL SEN/CIRC	P0462	0462	—	—	×	EC-1044
FUEL LEVL SEN/CIRC	P0463	0463	—	—	×	EC-1044
VEH SPEED SEN/CIRC*6	P0500	0500	—	—	×	EC-1046
ISC SYSTEM	P0506	0506	—	—	×	EC-1048

A
EC
C
D
E
F
G
H
I
J
K
L
M

ON BOARD DIAGNOSTIC (OBD) SYSTEM

[VK45DE]

Items (CONSULT-II screen terms)	DTC*1		SRT code	Test value/ Test limit (GST only)	1st trip DTC	Reference page
	CONSULT-II GST*2	ECM*3				
ISC SYSTEM	P0507	0507	—	—	×	EC-1050
PW ST P SEN/CIRC	P0550	0550	—	—	×	EC-1052
ECM	P0605	0605	—	—	× or —	EC-1057
PNP SW/CIRC	P0705	0705	—	—	×	AT-112
ATF TEMP SEN/CIRC	P0710	0710	—	—	×	AT-139
VEH SPD SEN/CIR AT*7	P0720	0720	—	—	×	AT-116
TCC SOLENOID/CIRC	P0740	0740	—	—	×	AT-123
A/T TCC S/V FNCTN	P0744	0744	—	—	×	AT-125
L/PRESS SOL/CIRC	P0745	0745	—	—	×	AT-127
ECM BACK UP/CIRC	P1065	1065	—	—	×	EC-1060
MAF SENSOR	P1102	1102	—	—	—	EC-1064
INT/V TIM V/CIR-B1	P1111	1111	—	—	×	EC-1070
ETC ACTR	P1121	1121	—	—	—	EC-1077
ETC FUNCTION/CIRC	P1122	1122	—	—	—	EC-1079
ETC MOT PWR	P1124	1124	—	—	—	EC-1085
ETC MOT PWR	P1126	1126	—	—	—	EC-1085
ETC MOT	P1128	1128	—	—	—	EC-1090
INT/V TIM V/CIR-B2	P1136	1136	—	—	×	EC-1070
INTK TIM S/CIRC-B1	P1140	1140	—	—	×	EC-1095
HO2S1 (B1)	P1143	1143	×	×	×	EC-1103
HO2S1 (B1)	P1144	1144	×	×	×	EC-1109
INTK TIM S/CIRC-B2	P1145	1145	—	—	×	EC-1095
HO2S2 (B1)	P1146	1146	×	×	×	EC-1116
HO2S2 (B1)	P1147	1147	×	×	×	EC-1127
CLOSED LOOP-B1	P1148	1148	—	—	—	EC-1138
HO2S1 (B2)	P1163	1163	×	×	×	EC-1103
HO2S1 (B2)	P1164	1164	×	×	×	EC-1109
HO2S2 (B2)	P1166	1166	×	×	×	EC-1116
HO2S2 (B2)	P1167	1167	×	×	×	EC-1127
CLOSED LOOP-B2	P1168	1168	—	—	—	EC-1138
TCS C/U FUNCTN	P1211	1211	—	—	×	EC-1140
TCS/CIRC	P1212	1212	—	—	×	EC-1141
ENG OVER TEMP	P1217	1217	—	—	—	EC-1142
CTP LEARNING	P1225	1225	—	—	×	EC-1152
CTP LEARNING	P1226	1226	—	—	×	EC-1154
SENSOR POWER/CIRC	P1229	1229	—	—	—	EC-1156
PURG VOLUME CONT/V	P1444	1444	—	—	×	EC-1160
VENT CONTROL VALVE	P1446	1446	—	—	×	EC-1168
ASCD SW*7 *8	P1564	1564	—	—	—	EC-1174, EC-1181
ACC COMMAND VALUE*7	P1568	1568	—	—	—	EC-1188
ASCD BRAKE SW*7 *8	P1572	1572	—	—	—	EC-1189, EC-1199

ON BOARD DIAGNOSTIC (OBD) SYSTEM

[VK45DE]

Items (CONSULT-II screen terms)	DTC*1		SRT code	Test value/ Test limit (GST only)	1st trip DTC	Reference page
	CONSULT-II GST*2	ECM*3				
ASCD VHL SPD SEN*7 *8	P1574	1574	—	—	—	EC-1207 , EC-1209
NATS MALFUNCTION	P1610 - P1615	1610 - 1615	—	—	×	EC-717
P-N POS SW/CIRCUIT	P1706	1706	—	—	×	EC-1211
TURBINE REV S/CIRC	P1716	1716	—	—	×	AT-143
V/SP SEN(A/T OUT)	P1720	1720	—	—	×	EC-1216
A/T INTERLOCK	P1730	1730	—	—	—	AT-147
I/C SOLENOID/CIRC	P1752	1752	—	—	—	AT-152
I/C SOLENOID FNCTN	P1754	1754	—	—	—	AT-154
FR/B SOLENOID/CIRC	P1757	1757	—	—	—	AT-156
FR/B SOLENOID/CIRC	P1759	1759	—	—	—	AT-158
D/C SOLENOID/CIRC	P1762	1762	—	—	—	AT-160
D/C SOLENOID FNCTN	P1764	1764	—	—	—	AT-162
HLR/C SOL/CIRC	P1767	1767	—	—	—	AT-164
HLR/C SOL FNCTN	P1769	1769	—	—	—	AT-166
LC/B SOLENOID/CIRC	P1772	1772	—	—	—	AT-168
LC/B SOLENOID FNCT	P1774	1774	—	—	—	AT-170
SHIFT SIG FNCTN	P1780	1780	—	—	×	EC-1218
BRAKE SW/CIRCUIT	P1805	1805	—	—	×	EC-1220
APP SEN 1/CIRC	P2122	2122	—	—	—	EC-1225
APP SEN 1/CIRC	P2123	2123	—	—	—	EC-1225
APP SEN 2/CIRC	P2127	2127	—	—	—	EC-1232
APP SEN 2/CIRC	P2128	2128	—	—	—	EC-1232
TP SENSOR	P2135	2135	—	—	—	EC-1239
APP SENSOR	P2138	2138	—	—	—	EC-1246

*1: 1st trip DTC No. is the same as DTC No.

*2: This number is prescribed by SAE J2012.

*3: In Diagnostic Test Mode II (Self-diagnostic results). These numbers are controlled by NISSAN.

*4: The trouble shooting for this DTC needs CONSULT-II.

*5: SRT code will not be set if the self-diagnostic result is NG.

*6: When the fail-safe operations for both self-diagnoses occur at the same time, the MIL illuminates.

*7: Models with ICC.

*8: Models with ASCD.

DTC AND 1ST TRIP DTC

The 1st trip DTC (whose number is the same as the DTC number) is displayed for the latest self-diagnostic result obtained. If the ECM memory was cleared previously, and the 1st trip DTC did not reoccur, the 1st trip DTC will not be displayed.

If a malfunction is detected during the 1st trip, the 1st trip DTC is stored in the ECM memory. The MIL will not light up (two trip detection logic). If the same malfunction is not detected in the 2nd trip (meeting the required driving pattern), the 1st trip DTC is cleared from the ECM memory. If the same malfunction is detected in the 2nd trip, both the 1st trip DTC and DTC are stored in the ECM memory and the MIL lights up. In other words, the DTC is stored in the ECM memory and the MIL lights up when the same malfunction occurs in two consecutive trips. If a 1st trip DTC is stored and a non-diagnostic operation is performed between the 1st and 2nd trips, only the 1st trip DTC will continue to be stored. For malfunctions that blink or light up the MIL during the 1st trip, the DTC and 1st trip DTC are stored in the ECM memory.

Procedures for clearing the DTC and the 1st trip DTC from the ECM memory are described in [EC-715, "HOW TO ERASE EMISSION-RELATED DIAGNOSTIC INFORMATION"](#).

For malfunctions in which 1st trip DTCs are displayed, refer to [EC-704, "EMISSION-RELATED DIAGNOSTIC INFORMATION ITEMS"](#) . These items are required by legal regulations to continuously monitor the system/component. In addition, the items monitored non-continuously are also displayed on CONSULT-II.

1st trip DTC is specified in Mode 7 of SAE J1979. 1st trip DTC detection occurs without lighting up the MIL and therefore does not warn the driver of a malfunction. However, 1st trip DTC detection will not prevent the vehicle from being tested, for example during Inspection/Maintenance (I/M) tests.

When a 1st trip DTC is detected, check, print out or write down and erase (1st trip) DTC and Freeze Frame data as specified in Work Flow procedure Step II, refer to [EC-727, "WORK FLOW"](#) . Then perform DTC Confirmation Procedure or Overall Function Check to try to duplicate the malfunction. If the malfunction is duplicated, the item requires repair.

How to Read DTC and 1st Trip DTC

DTC and 1st trip DTC can be read by the following methods.

 **With CONSULT-II**

 **With GST**

CONSULT-II or GST (Generic Scan Tool) Examples: P0340, P1148, P1706, etc.

These DTCs are prescribed by SAE J2012.

(CONSULT-II also displays the malfunctioning component or system.)

 **No Tools**

The number of blinks of the MIL in the Diagnostic Test Mode II (Self-Diagnostic Results) indicates the DTC. Example: 0340, 1148, 1706, etc.

These DTCs are controlled by NISSAN.

- **1st trip DTC No. is the same as DTC No.**
- **Output of a DTC indicates a malfunction. However, GST or the Diagnostic Test Mode II do not indicate whether the malfunction is still occurring or has occurred in the past and has returned to normal. CONSULT-II can identify malfunction status as shown below. Therefore, using CONSULT-II (if available) is recommended.**

A sample of CONSULT-II display for DTC and 1st trip DTC is shown below. DTC or 1st trip DTC of a malfunction is displayed in "SELF-DIAGNOSTIC RESULTS" mode of CONSULT-II. Time data indicates how many times the vehicle was driven after the last detection of a DTC.

If the DTC is being detected currently, the time data will be [0].

If a 1st trip DTC is stored in the ECM, the time data will be [1t].

DTC display	SELF DIAG RESULTS		1st trip DTC display	SELF DIAG RESULTS	
	DTC RESULTS TIME			DTC RESULTS TIME	
	CKP SEN/CIRCUIT [P0335]	0		CKP SEN/CIRCUIT [P0335]	1t

PBIB0911E

FREEZE FRAME DATA AND 1ST TRIP FREEZE FRAME DATA

The ECM records the driving conditions such as fuel system status, calculated load value, engine coolant temperature, short term fuel trim, long term fuel trim, engine speed, vehicle speed, base fuel schedule and intake air temperature at the moment a malfunction is detected.

Data which are stored in the ECM memory, along with the 1st trip DTC, are called 1st trip freeze frame data. The data, stored together with the DTC data, are called freeze frame data and displayed on CONSULT-II or GST. The 1st trip freeze frame data can only be displayed on the CONSULT-II screen, not on the GST. For details, see [EC-764, "Freeze Frame Data and 1st Trip Freeze Frame Data"](#) .

Only one set of freeze frame data (either 1st trip freeze frame data or freeze frame data) can be stored in the ECM. 1st trip freeze frame data is stored in the ECM memory along with the 1st trip DTC. There is no priority for 1st trip freeze frame data and it is updated each time a different 1st trip DTC is detected. However, once freeze frame data (2nd trip detection/MIL on) is stored in the ECM memory, 1st trip freeze frame data is no longer stored. Remember, only one set of freeze frame data can be stored in the ECM. The ECM has the following priorities to update the data.

ON BOARD DIAGNOSTIC (OBD) SYSTEM

[VK45DE]

Priority	Items	
1	Freeze frame data	Misfire — DTC: P0300 - P0308 Fuel Injection System Function — DTC: P0171, P0172, P0174, P0175
2		Except the above items (Includes A/T related items)
3	1st trip freeze frame data	

For example, the EGR malfunction (Priority: 2) was detected and the freeze frame data was stored in the 2nd trip. After that when the misfire (Priority: 1) is detected in another trip, the freeze frame data will be updated from the EGR malfunction to the misfire. The 1st trip freeze frame data is updated each time a different malfunction is detected. There is no priority for 1st trip freeze frame data. However, once freeze frame data is stored in the ECM memory, 1st trip freeze data is no longer stored (because only one freeze frame data or 1st trip freeze frame data can be stored in the ECM). If freeze frame data is stored in the ECM memory and freeze frame data with the same priority occurs later, the first (original) freeze frame data remains unchanged in the ECM memory.

Both 1st trip freeze frame data and freeze frame data (along with the DTCs) are cleared when the ECM memory is erased. Procedures for clearing the ECM memory are described in [EC-715, "HOW TO ERASE EMISSION-RELATED DIAGNOSTIC INFORMATION"](#).

SYSTEM READINESS TEST (SRT) CODE

System Readiness Test (SRT) code is specified in Mode 1 of SAE J1979.

As part of an enhanced emissions test for Inspection & Maintenance (I/M), certain states require the status of SRT be used to indicate whether the ECM has completed self-diagnosis of major emission systems and components. Completion must be verified in order for the emissions inspection to proceed.

If a vehicle is rejected for a State emissions inspection due to one or more SRT items indicating "INCMP", use the information in this Service Manual to set the SRT to "CMPLT".

In most cases the ECM will automatically complete its self-diagnosis cycle during normal usage, and the SRT status will indicate "CMPLT" for each application system. Once set as "CMPLT", the SRT status remains "CMPLT" until the self-diagnosis memory is erased.

Occasionally, certain portions of the self-diagnostic test may not be completed as a result of the customer's normal driving pattern; the SRT will indicate "INCMP" for these items.

NOTE:

The SRT will also indicate "INCMP" if the self-diagnosis memory is erased for any reason or if the ECM memory power supply is interrupted for several hours.

If, during the state emissions inspection, the SRT indicates "CMPLT" for all test items, the inspector will continue with the emissions test. However, if the SRT indicates "INCMP" for one or more of the SRT items the vehicle is returned to the customer untested.

NOTE:

If MIL is ON during the state emissions inspection, the vehicle is also returned to the customer untested even though the SRT indicates "CMPLT" for all test items. Therefore, it is important to check SRT ("CMPLT") and DTC (No DTCs) before the inspection.

SRT Item

The table below shows required self-diagnostic items to set the SRT to "CMPLT".

SRT item (CONSULT-II indication)	Performance Priority*	Required self-diagnostic items to set the SRT to "CMPLT"	Corresponding DTC No.
CATALYST	2	Three way catalyst function	P0420, P0430
EVAP SYSTEM	1	EVAP control system	P0442
	2	EVAP control system	P0456
	2	EVAP control system purge flow monitoring	P0441
HO2S	2	Heated oxygen sensor 1	P0133, P0153
		Heated oxygen sensor 1	P1143, P1163
		Heated oxygen sensor 1	P1144, P1164
		Heated oxygen sensor 2	P0139, P0159
		Heated oxygen sensor 2	P1146, P1166
		Heated oxygen sensor 2	P1147, P1167

ON BOARD DIAGNOSTIC (OBD) SYSTEM

[VK45DE]

SRT item (CONSULT-II indication)	Performance Priority*	Required self-diagnostic items to set the SRT to "CMPLT"	Corresponding DTC No.
HO2S HTR	2	Heated oxygen sensor 1 heater	P0031, P0032, P0051, P0052
		Heated oxygen sensor 2 heater	P0037, P0038, P0057, P0058

*: If completion of several SRTs is required, perform driving patterns (DTC confirmation procedure), one by one based on the priority for models with CONSULT-II.

SRT Set Timing

SRT is set as "CMPLT" after self-diagnosis has been performed one or more times. Completion of SRT is done regardless of whether the result is OK or NG. The set timing is different between OK and NG results and is shown in the table below.

Self-diagnosis result		Example					
		Diagnosis	Ignition cycle				
← ON →	OFF		← ON →	OFF	← ON →	OFF	
All OK	Case 1	P0400	OK (1)	— (1)	OK (2)	— (2)	
		P0402	OK (1)	— (1)	— (1)	OK (2)	
		P1402	OK (1)	OK (2)	— (2)	— (2)	
		SRT of EGR	"CMPLT"	"CMPLT"	"CMPLT"	"CMPLT"	
	Case 2	P0400	OK (1)	— (1)	— (1)	— (1)	
		P0402	— (0)	— (0)	OK (1)	— (1)	
		P1402	OK (1)	OK (2)	— (2)	— (2)	
		SRT of EGR	"INCMP"	"INCMP"	"CMPLT"	"CMPLT"	
NG exists	Case 3	P0400	OK	OK	—	—	
		P0402	—	—	—	—	
		P1402	NG	—	NG	NG	NG (Consecutive NG)
		(1st trip) DTC	1st trip DTC	—	1st trip DTC	DTC (= MIL "ON")	
		SRT of EGR	"INCMP"	"INCMP"	"INCMP"	"CMPLT"	

OK: Self-diagnosis is carried out and the result is OK.

NG: Self-diagnosis is carried out and the result is NG.

—: Self-diagnosis is not carried out.

When all SRT related self-diagnoses showed OK results in a single cycle (Ignition OFF-ON-OFF), the SRT will indicate "CMPLT". → Case 1 above

When all SRT related self-diagnoses showed OK results through several different cycles, the SRT will indicate "CMPLT" at the time the respective self-diagnoses have at least one OK result. → Case 2 above

If one or more SRT related self-diagnoses showed NG results in 2 consecutive cycles, the SRT will also indicate "CMPLT". → Case 3 above

The table above shows that the minimum number of cycles for setting SRT as "INCMP" is one (1) for each self-diagnosis (Case 1 & 2) or two (2) for one of self-diagnoses (Case 3). However, in preparation for the state emissions inspection, it is unnecessary for each self-diagnosis to be executed twice (Case 3) for the following reasons:

- The SRT will indicate "CMPLT" at the time the respective self-diagnoses have one (1) OK result.
- The emissions inspection requires "CMPLT" of the SRT only with OK self-diagnosis results.
- When, during SRT driving pattern, 1st trip DTC (NG) is detected prior to "CMPLT" of SRT, the self-diagnosis memory must be erased from ECM after repair.
- If the 1st trip DTC is erased, all the SRT will indicate "INCMP".

NOTE:

SRT can be set as "CMPLT" together with the DTC(s). Therefore, DTC check must always be carried out prior to the state emission inspection even though the SRT indicates "CMPLT".

SRT Service Procedure

If a vehicle has failed the state emissions inspection due to one or more SRT items indicating "INCMP", review the flowchart diagnostic sequence on the next page.

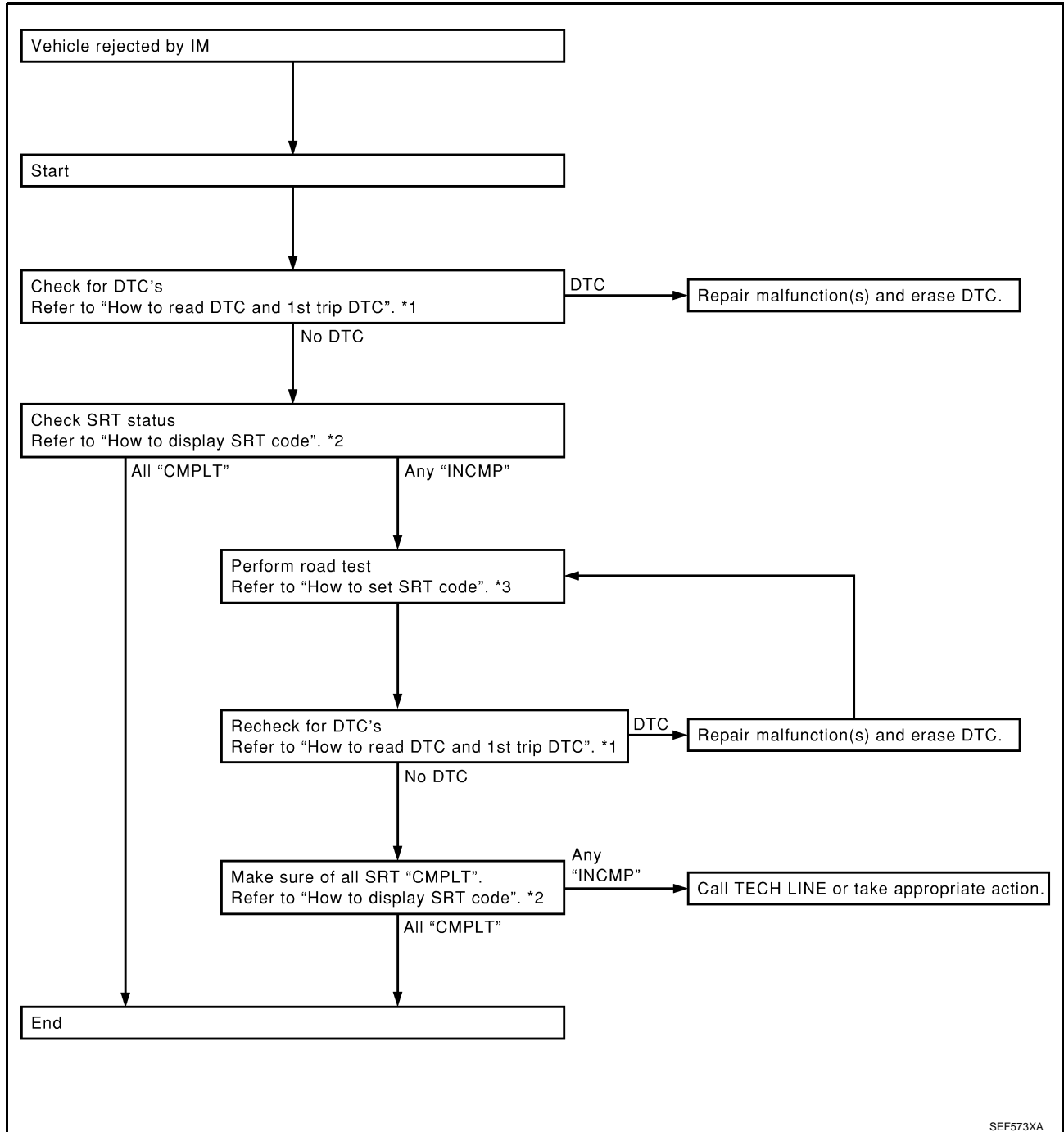

*1 [EC-708](#)

*2 [EC-712](#)

*3 [EC-712](#)

SEF573XA

How to Display SRT Code

WITH CONSULT-II

Selecting "SRT STATUS" in "DTC CONFIRMATION" mode with CONSULT-II.

For items whose SRT codes are set, a "CMPLT" is displayed on the CONSULT-II screen; for items whose SRT codes are not set, "INCMP" is displayed.

A sample of CONSULT-II display for SRT code is shown at right.

"INCMP" means the self-diagnosis is incomplete and SRT is not set.

"CMPLT" means the self-diagnosis is complete and SRT is set.

WITH GST

Selecting MODE 1 with GST (Generic Scan Tool)

SRT STATUS	
CATALYST	CMPLT
EVAP SYSTEM	INCMP
HO2S HTR	CMPLT
HO2S	CMPLT

SEF935Z

How to Set SRT Code

To set all SRT codes, self-diagnosis for the items indicated above must be performed one or more times. Each diagnosis may require a long period of actual driving under various conditions.

WITH CONSULT-II

Perform corresponding DTC Confirmation Procedure one by one based on Performance Priority in the table on [EC-709, "SRT Item"](#).

WITHOUT CONSULT-II

The most efficient driving pattern in which SRT codes can be properly set is explained on the next page. The driving pattern should be performed one or more times to set all SRT codes.

Driving Pattern

Note: Always drive vehicle in safe manner according to traffic conditions and obey all traffic laws. Refer to next page for more information and explanation of chart.

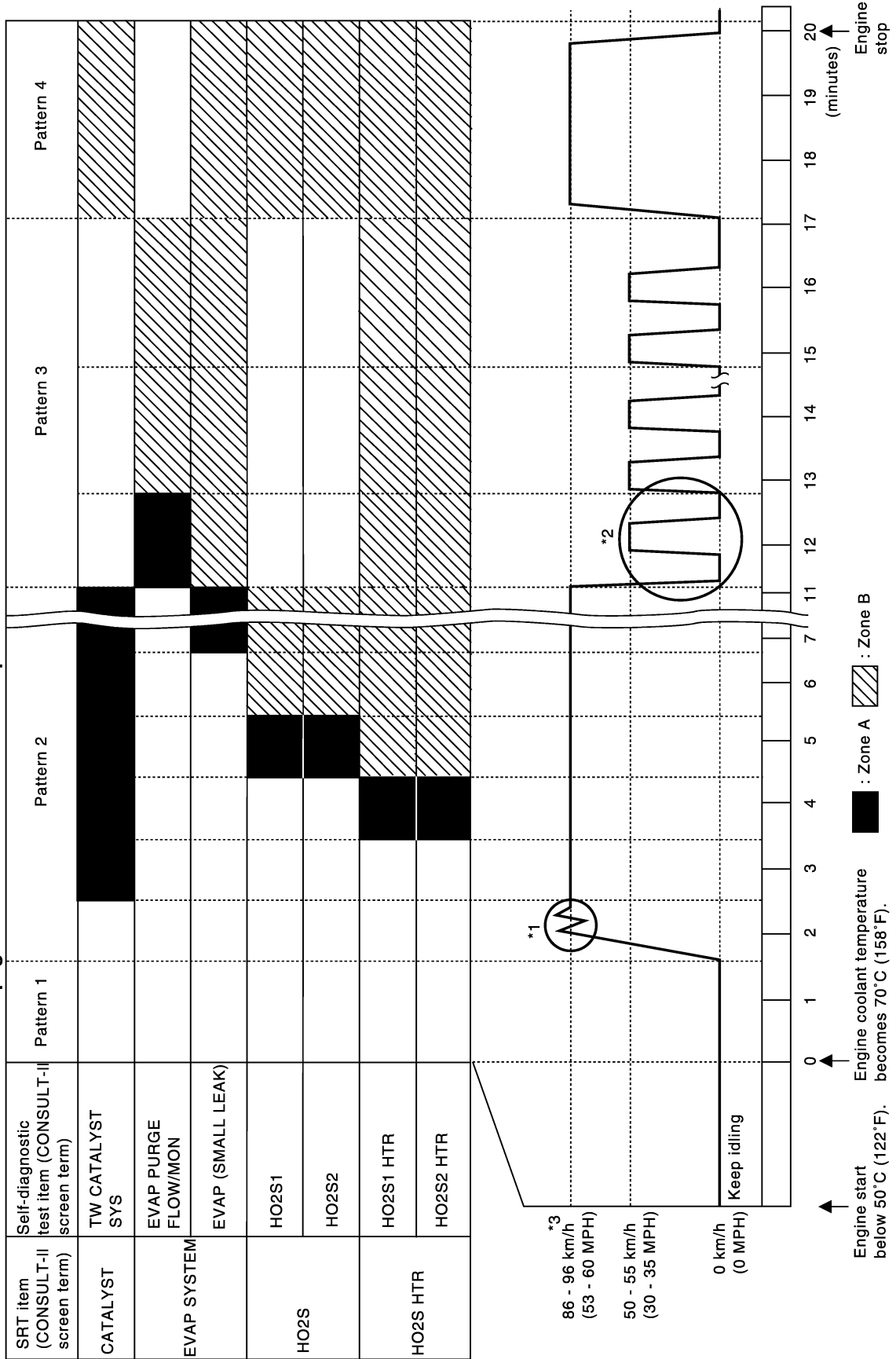

PBIB1053E

A
EC
C
D
E
F
G
H
I
J
K
L
M

ON BOARD DIAGNOSTIC (OBD) SYSTEM

[VK45DE]

- The time required for each diagnosis varies with road surface conditions, weather, altitude, individual driving habits, etc.
Zone A refers to the range where the time, required for the diagnosis under normal conditions*, is the shortest.
Zone B refers to the range where the diagnosis can still be performed if the diagnosis is not completed within zone A.

*: Normal conditions refer to the following:

- Sea level
- Flat road
- Ambient air temperature: 20 - 30°C (68 - 86°F)
- Diagnosis is performed as quickly as possible under normal conditions.
Under different conditions [For example: ambient air temperature other than 20 - 30°C (68 - 86°F)], diagnosis may also be performed.

Pattern 1:

- **The engine is started at the engine coolant temperature of -10 to 35°C (14 to 95°F) (where the voltage between the ECM terminal 73 and ground is 3.0 - 4.3V).**
- **The engine must be operated at idle speed until the engine coolant temperature is greater than 70°C (158°F) (where the voltage between the ECM terminal 73 and ground is lower than 1.4V).**
- **The engine is started at the fuel tank temperature of warmer than 0°C (32°F) (where the voltage between the ECM terminal 107 and ground is less than 4.1V).**

Pattern 2:

- When steady-state driving is performed again even after it is interrupted, each diagnosis can be conducted. In this case, the time required for diagnosis may be extended.

Pattern 3:

- The driving pattern outlined in *2 must be repeated at least 3 times.

Pattern 4:

- Tests are performed after the engine has been operated for at least 17 minutes.
- The accelerator pedal must be held very steady during steady-state driving.
- If the accelerator pedal is moved, the test must be conducted all over again.

*1: Depress the accelerator pedal until vehicle speed is 90 km/h (56 MPH), then release the accelerator pedal and keep it released for more than 10 seconds. Depress the accelerator pedal until vehicle speed is 90 km/h (56 MPH) again.

*2: Operate the vehicle in the following driving pattern.

1. Decelerate vehicle to 0 km/h (0 MPH) and let engine idle.
2. Repeat driving pattern shown at right at least 10 times.
- **During acceleration, hold the accelerator pedal as steady as possible.**

*3: Checking the vehicle speed with GST is advised.

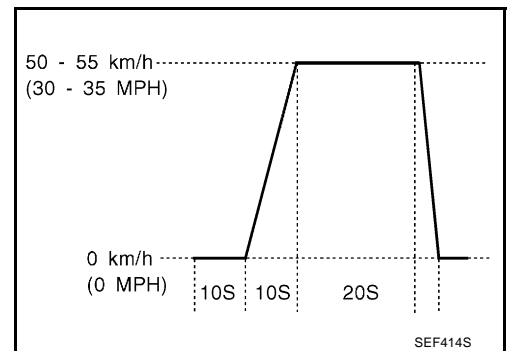

Suggested Transmission Gear Position

Set the selector lever in the D position.

TEST VALUE AND TEST LIMIT (GST ONLY — NOT APPLICABLE TO CONSULT-II)

The following is the information specified in Mode 6 of SAE J1979.

The test value is a parameter used to determine whether a system/circuit diagnostic test is OK or NG while being monitored by the ECM during self-diagnosis. The test limit is a reference value which is specified as the maximum or minimum value and is compared with the test value being monitored.

These data (test value and test limit) are specified by Test ID (TID) and Component ID (CID) and can be displayed on the GST screen.

ON BOARD DIAGNOSTIC (OBD) SYSTEM

[VK45DE]

Item	Self-diagnostic test item	DTC	Test value (GST display)		Test limit	Conversion
			TID	CID		
CATALYST	Three way catalyst function (Bank 1)	P0420	01H	01H	Max.	1/128
		P0420	02H	81H	Min.	1
	Three way catalyst function (Bank 2)	P0430	03H	02H	Max.	1/128
		P0430	04H	82H	Min.	1
EVAP SYSTEM	EVAP control system (Small leak)	P0442	05H	03H	Max.	1/128mm ²
	EVAP control system purge flow monitoring	P0441	06H	83H	Min.	20mV
	EVAP control system (Very small leak)	P0456	07H	03H	Max.	1/128mm ²
HO2S	Heated oxygen sensor 1 (Bank 1)	P0133	09H	04H	Max.	16ms
		P1143	0AH	84H	Min.	10mV
		P1144	0BH	04H	Max.	10mV
		P0132	0CH	04H	Max.	10mV
		P0134	0DH	04H	Max.	1s
	Heated oxygen sensor 1 (Bank 2)	P0153	11H	05H	Max.	16ms
		P1163	12H	85H	Min.	10mV
		P1164	13H	05H	Max.	10mV
		P0152	14H	05H	Max.	10mV
		P0154	15H	05H	Max.	1s
	Heated oxygen sensor 2 (Bank 1)	P0139	19H	86H	Min.	10mV/500ms
		P1147	1AH	86H	Min.	10mV
		P1146	1BH	06H	Max.	10mV
		P0138	1CH	06H	Max.	10mV
	Heated oxygen sensor 2 (Bank 2)	P0159	21H	87H	Min.	10mV/500ms
		P1167	22H	87H	Min.	10mV
P1166		23H	07H	Max.	10mV	
P0158		24H	07H	Max.	10mV	
HO2S HEATER	Heated oxygen sensor 1 heater (Bank 1)	P0032	29H	08H	Max.	20mV
		P0031	2AH	88H	Min.	20mV
	Heated oxygen sensor 1 heater (Bank 2)	P0052	2BH	09H	Max.	20mV
		P0051	2CH	89H	Min.	20mV
	Heated oxygen sensor 2 heater (Bank 1)	P0038	2DH	0AH	Max.	20mV
		P0037	2EH	8AH	Min.	20mV
Heated oxygen sensor 2 heater (Bank 2)	P0058	2FH	0BH	Max.	20mV	
	P0057	30H	8BH	Min.	20mV	

HOW TO ERASE EMISSION-RELATED DIAGNOSTIC INFORMATION

How to Erase DTC

With CONSULT-II

The emission related diagnostic information in the ECM can be erased by selecting "ERASE" in the "SELF-DIAG RESULTS" mode with CONSULT-II.

If DTCs are displayed for both ECM and TCM (Transmission control module), they need to be erased individually from the ECM and TCM (Transmission control module).

NOTE:

If the DTC is not for A/T related items (see [EC-662](#)), skip steps 2 through 4.

1. If the ignition switch stays ON after repair work, be sure to turn ignition switch OFF once. Wait at least 10 seconds and then turn it ON (engine stopped) again.
2. Turn CONSULT-II ON and touch "A/T".

3. Touch "SELF-DIAG RESULTS".
4. Touch "ERASE". [The DTC in the TCM (Transmission control module) will be erased.] Then touch "BACK" twice.
5. Touch "ENGINE".
6. Touch "SELF-DIAG RESULTS".
7. Touch "ERASE". (The DTC in the ECM will be erased.)

How to erase DTC (With CONSULT-II)

1. If the ignition switch stays "ON" after repair work, be sure to turn ignition switch "OFF" once. Wait at least 10 seconds and then turn it "ON" (engine stopped) again.

SELECT SYSTEM
A/T
ENGINE

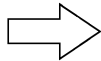

SELECT DIAG MODE
SELF-DIAG RESULTS
DATE MONITOR
CAN DIAG SUPPORT MNTR
DTC WORK SUPPORT
ECU PART NUMBER

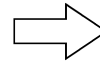

SELF-DIAG RESULTS
DTC RESULTS
TCC SOLENOID/CIRC [P0740]

2. Turn CONSULT-II "ON", and touch "A/T".

3. Touch "SELF-DIAG RESULTS".

4. Touch "ERASE". (The DTC in the TCM will be erased.)

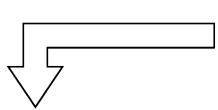

Touch "BACK".

Touch "BACK".

SELECT SYSTEM
A/T
ENGINE

SELECT DIAG MODE
WORK SUPPORT
SELF-DIAG RESULTS
DATE MONITOR
DATA MONITOR(SPEC)
CAN DIAG SUPPORT MNTR
ACTIVE TEST

SELF-DIAG RESULTS	
DTC RESULTS	TIME
TCC SOLENOID/CIRC [P0740]	0

5. Touch "ENGINE".

6. Touch "SELF-DIAG RESULTS".

7. Touch "ERASE". (The DTC in the ECM will be erased.)

SCIA5334E

With GST

The emission related diagnostic information in the ECM can be erased by selecting MODE 4 with GST.

NOTE:

If the DTC is not for A/T related items (see [EC-662](#)), skip step 2.

1. If the ignition switch stays ON after repair work, be sure to turn ignition switch OFF once. Wait at least 10 seconds and then turn it ON (engine stopped) again.
2. Perform [AT-40, "HOW TO ERASE DTC \(WITH GST\)"](#). (The DTC in TCM will be erased.)
3. Select MODE 4 with GST (Generic Scan Tool).

No Tools

NOTE:

If the DTC is not for A/T related items (see [EC-662](#)), skip step 2.

1. If the ignition switch stays ON after repair work, be sure to turn ignition switch OFF once. Wait at least 10 seconds and then turn it ON (engine stopped) again.
 2. Perform [AT-41, "HOW TO ERASE DTC \(NO TOOLS\)"](#). (The DTC in TCM will be erased.)
 3. Change the diagnostic test mode from Mode II to Mode I by depressing the accelerator pedal. Refer to [EC-719, "HOW TO SWITCH DIAGNOSTIC TEST MODE"](#).
- If the battery is disconnected, the emission-related diagnostic information will be lost within 24 hours.

- **The following data are cleared when the ECM memory is erased.**
 - Diagnostic trouble codes
 - 1st trip diagnostic trouble codes
 - Freeze frame data
 - 1st trip freeze frame data
 - System readiness test (SRT) codes
 - Test values
 - Others

Actual work procedures are explained using a DTC as an example. Be careful so that not only the DTC, but all of the data listed above, are cleared from the ECM memory during work procedures.

IVIS (Infiniti Vehicle Immobilizer System — NATS)

ABS00BZL

- If the security indicator lights up with the ignition switch in the ON position or “NATS MALFUNCTION” is displayed on “SELF-DIAG RESULTS” screen, perform self-diagnostic results mode with CONSULT-II using NATS program card. Refer to [BL-206, "IVIS \(INFINITI VEHICLE IMMOBILIZER SYSTEM-NATS\)"](#).
- Confirm no self-diagnostic results of IVIS (NATS) is displayed before touching “ERASE” in “SELF-DIAG RESULTS” mode with CONSULT-II.
- When replacing ECM, initialization of IVIS (NATS) system and registration of all IVIS (NATS) ignition key IDs must be carried out with CONSULT-II using NATS program card.

SELF DIAG RESULTS	
DTC RESULTS	TIME
NATS MALFUNCTION [P1610]	0

SEF543X

Therefore, be sure to receive all keys from vehicle owner. Regarding the procedures of IVIS (NATS) initialization and IVIS (NATS) ignition key ID registration, refer to CONSULT-II operation manual, IVIS/NVIS.

Malfunction Indicator Lamp (MIL) DESCRIPTION

ABS00BZM





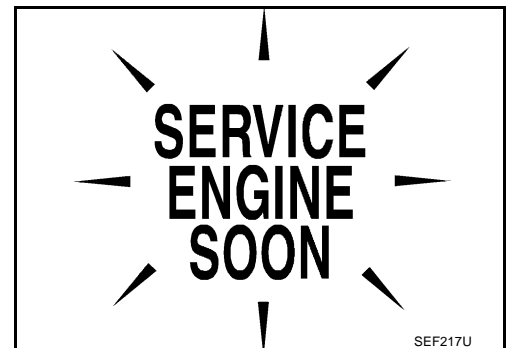

The MIL is located on the instrument panel.

1. The MIL will light up when the ignition switch is turned ON without the engine running. This is a bulb check. If the MIL does not light up, refer to [DI-39, "WARNING LAMPS"](#), or see [EC-1318](#).
2. When the engine is started, the MIL should go off. If the MIL remains on, the on board diagnostic system has detected an engine system malfunction.



ON BOARD DIAGNOSTIC SYSTEM FUNCTION

The on board diagnostic system has the following four functions.

Diagnostic Test Mode	KEY and ENG. Status	Function	Explanation of Function
Mode I	Ignition switch in ON position  Engine stopped 	BULB CHECK	This function checks the MIL bulb for damage (blown, open circuit, etc.). If the MIL does not come on, check MIL circuit.
	Engine running 	MALFUNCTION WARNING	This is a usual driving condition. When a malfunction is detected twice in two consecutive driving cycles (two trip detection logic), the MIL will light up to inform the driver that a malfunction has been detected. The following malfunctions will light up or blink the MIL in the 1st trip. <ul style="list-style-type: none"> ● Misfire (Possible three way catalyst damage) ● One trip detection diagnoses
Mode II	Ignition switch in ON position  Engine stopped 	SELF-DIAGNOSTIC RESULTS	This function allows DTCs and 1st trip DTCs to be read.
	Engine running 	HEATED OXYGEN SENSOR 1 MONITOR	This function allows the fuel mixture condition (lean or rich), monitored by heated oxygen sensor 1, to be read.

When there is an open circuit on MIL circuit, the ECM cannot warn the driver by lighting MIL up when there is malfunction on engine control system.

Therefore, when electrical controlled throttle and part of ECM related diagnoses are continuously detected as NG for 5 trips, ECM warns the driver that engine control system malfunctions and MIL circuit is open by means of operating fail-safe function.

The fail-safe function also operates when above diagnoses except MIL circuit are detected and demands the driver to repair the malfunction.

Engine operating condition in fail-safe mode	Engine speed will not rise more than 2,500 rpm due to the fuel cut
--	--

MIL Flashing Without DTC

If the ECM is in Diagnostic Test Mode II, MIL may flash when engine is running. In this case, check ECM diagnostic test mode. [EC-719, "HOW TO SWITCH DIAGNOSTIC TEST MODE"](#) .

How to switch the diagnostic test (function) modes, and details of the above functions are described later. [EC-719, "HOW TO SWITCH DIAGNOSTIC TEST MODE"](#) .

The following emission-related diagnostic information is cleared when the ECM memory is erased.

- Diagnostic trouble codes
- 1st trip diagnostic trouble codes
- Freeze frame data
- 1st trip freeze frame data
- System readiness test (SRT) codes
- Test values
- Others

HOW TO SWITCH DIAGNOSTIC TEST MODE

NOTE:

- It is better to count the time accurately with a clock.
- It is impossible to switch the diagnostic mode when an accelerator pedal position sensor circuit has a malfunction.
- Always ECM returns to Diagnostic Test Mode I after ignition switch is turned OFF.

How to Set Diagnostic Test Mode II (Self-diagnostic Results)

1. Confirm that accelerator pedal is fully released, turn ignition switch ON and wait 3 seconds.
2. Repeat the following procedure quickly five times within 5 seconds.
 - a. Fully depress the accelerator pedal.
 - b. Fully release the accelerator pedal.
3. Wait 7 seconds, fully depress the accelerator pedal and keep it for approx. 10 seconds until the MIL starts blinking.
4. Fully release the accelerator pedal.
ECM has entered to Diagnostic Test Mode II (Self-diagnostic results).

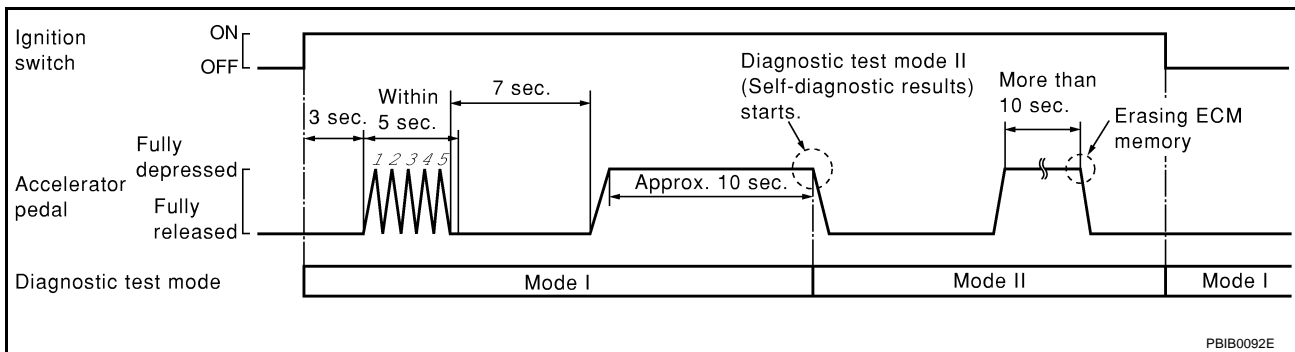

How to Set Diagnostic Test Mode II (Heated Oxygen Sensor 1 Monitor)

1. Set the ECM in Diagnostic Test Mode II (Self-diagnostic results). Refer to [EC-719, "How to Set Diagnostic Test Mode II \(Self-diagnostic Results\)"](#).
2. Start Engine.
ECM has entered to Diagnostic Test Mode II (Heated oxygen sensor 1 monitor).
ECM will start heated oxygen sensor 1 monitoring from the bank 1 sensor.

How to Switch Monitored Sensor From Bank 1 to Bank 2 or Vice Versa

1. Fully depress the accelerator pedal quickly and then release it immediately.
2. Make sure that monitoring sensor has changed by MIL blinking as follows.

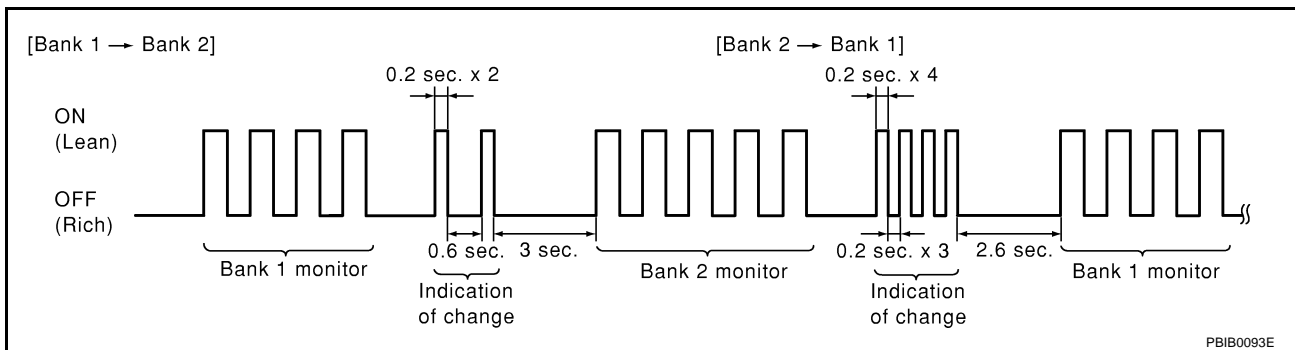

How to Erase Diagnostic Test Mode II (Self-diagnostic Results)

1. Set ECM in Diagnostic Test Mode II (Self-diagnostic results). Refer to [EC-719, "How to Set Diagnostic Test Mode II \(Self-diagnostic Results\)"](#).
2. Fully depress the accelerator pedal and keep it for more than 10 seconds.
The emission-related diagnostic information has been erased from the backup memory in the ECM.
3. Fully release the accelerator pedal, and confirm the DTC 0000 is displayed.

DIAGNOSTIC TEST MODE I — BULB CHECK

In this mode, the MIL on the instrument panel should stay ON. If it remains OFF, check the bulb. Refer to [DI-39, "WARNING LAMPS"](#) or see [EC-1318](#).

DIAGNOSTIC TEST MODE I — MALFUNCTION WARNING

MIL	Condition
ON	When the malfunction is detected.
OFF	No malfunction.

These DTC numbers are clarified in Diagnostic Test Mode II (SELF-DIAGNOSTIC RESULTS)

DIAGNOSTIC TEST MODE II — SELF-DIAGNOSTIC RESULTS

In this mode, the DTC and 1st trip DTC are indicated by the number of blinks of the MIL as shown below. The DTC and 1st trip DTC are displayed at the same time. If the MIL does not illuminate in diagnostic test mode I (Malfunction warning), all displayed items are 1st trip DTCs. If only one code is displayed when the MIL illuminates in diagnostic test mode II (SELF-DIAGNOSTIC RESULTS), it is a DTC; if two or more codes are displayed, they may be either DTCs or 1st trip DTCs. DTC No. is same as that of 1st trip DTC. These unidentified codes can be identified by using the CONSULT-II or GST. A DTC will be used as an example for how to read a code.

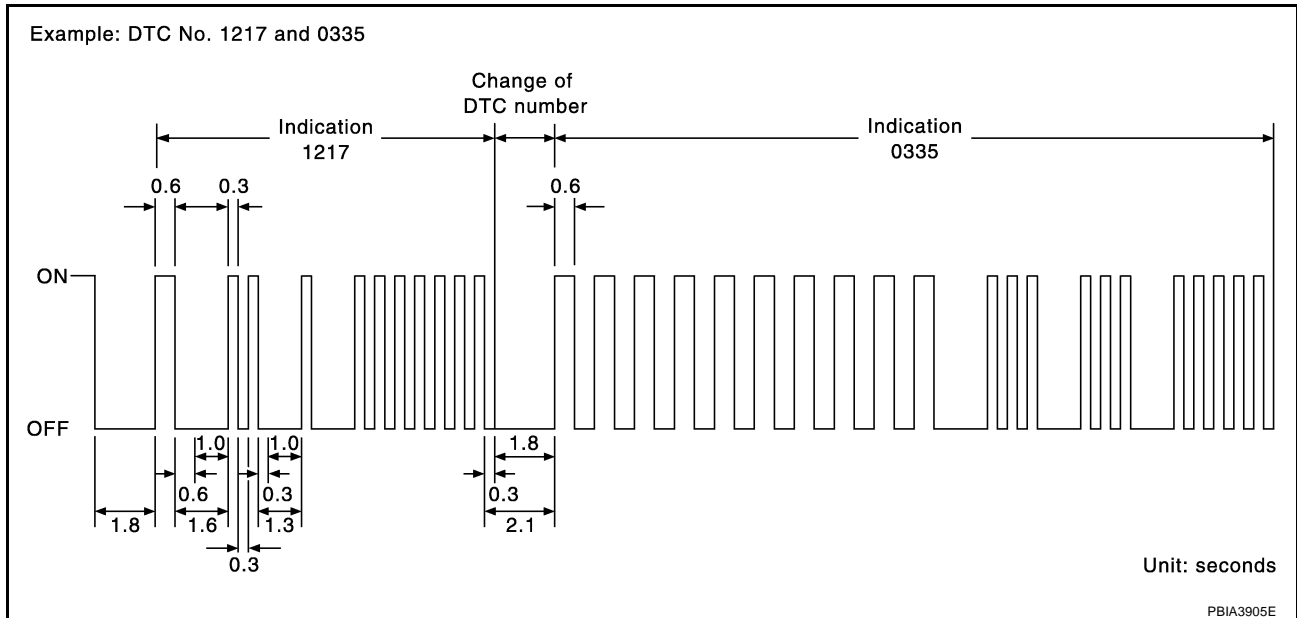

A particular trouble code can be identified by the number of four-digit numeral flashes. The “zero” is indicated by the number of ten flashes. The length of time the 1,000th-digit numeral flashes on and off is 1.2 seconds consisting of an ON (0.6-second) - OFF (0.6-second) cycle.

The 100th-digit numeral and lower digit numerals consist of a 0.3-second ON and 0.3-second OFF cycle.

A change from one digit numeral to another occurs at an interval of 1.0-second OFF. In other words, the later numeral appears on the display 1.3 seconds after the former numeral has disappeared.

A change from one trouble code to another occurs at an interval of 1.8-second OFF.

In this way, all the detected malfunctions are classified by their DTC numbers. The DTC 0000 refers to no malfunction. (See [EC-662, "INDEX FOR DTC"](#))

How to Erase Diagnostic Test Mode II (Self-diagnostic Results)

The DTC can be erased from the back up memory in the ECM by depressing accelerator pedal. Refer to [EC-719, "How to Erase Diagnostic Test Mode II \(Self-diagnostic Results\)"](#).

- If the battery is disconnected, the DTC will be lost from the backup memory within 24 hours.
- Be careful not to erase the stored memory before starting trouble diagnoses.

DIAGNOSTIC TEST MODE II — HEATED OXYGEN SENSOR 1 MONITOR

In this mode, the MIL displays the condition of the fuel mixture (lean or rich) which is monitored by the heated oxygen sensor 1.

ON BOARD DIAGNOSTIC (OBD) SYSTEM

[VK45DE]

MIL	Fuel mixture condition in the exhaust gas	Air fuel ratio feedback control condition
ON	Lean	Closed loop system
OFF	Rich	
*Remains ON or OFF	Any condition	Open loop system

*: Maintains conditions just before switching to open loop.

To check the heated oxygen sensor 1 function, start engine in the Diagnostic Test Mode II and warm it up until engine coolant temperature indicator points to the middle of the gauge.

Next run engine at about 2,000 rpm for about 2 minutes under no load conditions. Then make sure that the MIL comes ON more than 5 times within 10 seconds with engine running at 2,000 rpm under no load.

OBD System Operation Chart

ABS00BZN

RELATIONSHIP BETWEEN MIL, 1ST TRIP DTC, DTC, AND DETECTABLE ITEMS

- When a malfunction is detected for the first time, the 1st trip DTC and the 1st trip freeze frame data are stored in the ECM memory.
- When the same malfunction is detected in two consecutive trips, the DTC and the freeze frame data are stored in the ECM memory, and the MIL will come on. For details, refer to [EC-703, "Two Trip Detection Logic"](#).
- The MIL will go off after the vehicle is driven 3 times with no malfunction. The drive is counted only when the recorded driving pattern is met (as stored in the ECM). If another malfunction occurs while counting, the counter will reset.
- The DTC and the freeze frame data will be stored until the vehicle is driven 40 times (driving pattern A) without the same malfunction recurring (except for Misfire and Fuel Injection System). For Misfire and Fuel Injection System, the DTC and freeze frame data will be stored until the vehicle is driven 80 times (driving pattern C) without the same malfunction recurring. The "TIME" in "SELF-DIAGNOSTIC RESULTS" mode of CONSULT-II will count the number of times the vehicle is driven.
- The 1st trip DTC is not displayed when the self-diagnosis results in OK for the 2nd trip.

SUMMARY CHART

Items	Fuel Injection System	Misfire	Other
MIL (goes off)	3 (pattern B)	3 (pattern B)	3 (pattern B)
DTC, Freeze Frame Data (no display)	80 (pattern C)	80 (pattern C)	40 (pattern A)
1st Trip DTC (clear)	1 (pattern C), *1	1 (pattern C), *1	1 (pattern B)
1st Trip Freeze Frame Data (clear)	*1, *2	*1, *2	1 (pattern B)

For details about patterns B and C under "Fuel Injection System" and "Misfire", see [EC-723](#).

For details about patterns A and B under "Other", see [EC-725](#).

*1: Clear timing is at the moment OK is detected.

*2: Clear timing is when the same malfunction is detected in the 2nd trip.

RELATIONSHIP BETWEEN MIL, DTC, 1ST TRIP DTC AND DRIVING PATTERNS FOR "MISFIRE" "EXHAUST QUALITY DETERIORATION", "FUEL INJECTION SYSTEM"

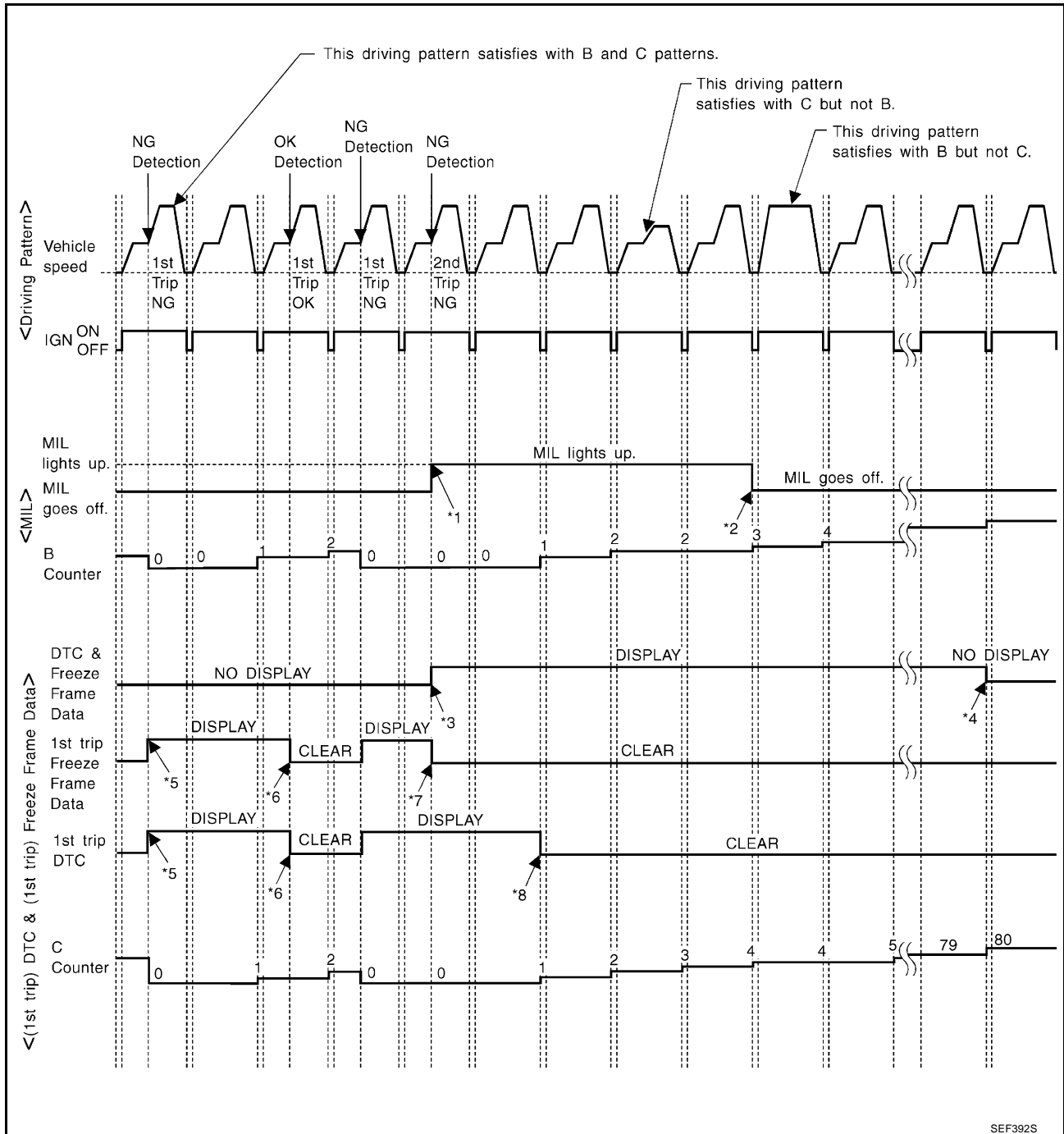

SEF392S

- *1: When the same malfunction is detected in two consecutive trips, MIL will light up.
- *2: MIL will go off after vehicle is driven 3 times (pattern B) without any malfunctions.
- *3: When the same malfunction is detected in two consecutive trips, the DTC and the freeze frame data will be stored in ECM.
- *4: The DTC and the freeze frame data will not be displayed any longer after vehicle is driven 80 times (pattern C) without the same malfunction. (The DTC and the freeze frame data still remain in ECM.)
- *5: When a malfunction is detected for the first time, the 1st trip DTC and the 1st trip freeze frame data will be stored in ECM.
- *6: The 1st trip DTC and the 1st trip freeze frame data will be cleared at the moment OK is detected.
- *7: When the same malfunction is detected in the 2nd trip, the 1st trip freeze frame data will be cleared.
- *8: 1st trip DTC will be cleared when vehicle is driven once (pattern C) without the same malfunction after DTC is stored in ECM.

EXPLANATION FOR DRIVING PATTERNS FOR “MISFIRE <EXHAUST QUALITY DETERIORATION>”, “FUEL INJECTION SYSTEM”**<Driving Pattern B>**

Driving pattern B means the vehicle operation as follows:

All components and systems should be monitored at least once by the OBD system.

- The B counter will be cleared when the malfunction is detected once regardless of the driving pattern.
- The B counter will be counted up when driving pattern B is satisfied without any malfunction.
- The MIL will go off when the B counter reaches 3. (*2 in OBD SYSTEM OPERATION CHART)

<Driving Pattern C>

Driving pattern C means the vehicle operation as follows:

The following conditions should be satisfied at the same time:

Engine speed: (Engine speed in the freeze frame data) ± 375 rpm

Calculated load value: (Calculated load value in the freeze frame data) $\times (1 \pm 0.1)$ [%]

Engine coolant temperature (T) condition:

- When the freeze frame data shows lower than 70°C (158°F), T should be lower than 70°C (158°F).
- When the freeze frame data shows higher than or equal to 70°C (158°F), T should be higher than or equal to 70°C (158°F).

Example:

If the stored freeze frame data is as follows:

Engine speed: 850 rpm, Calculated load value: 30%, Engine coolant temperature: 80°C (176°F)

To be satisfied with driving pattern C, the vehicle should run under the following conditions:

Engine speed: 475 - 1,225 rpm, Calculated load value: 27 - 33%, Engine coolant temperature: more than 70°C (158°F)

- The C counter will be cleared when the malfunction is detected regardless of vehicle conditions above.
- The C counter will be counted up when vehicle conditions above is satisfied without the same malfunction.
- The DTC will not be displayed after C counter reaches 80.
- The 1st trip DTC will be cleared when C counter is counted once without the same malfunction after DTC is stored in ECM.

ON BOARD DIAGNOSTIC (OBD) SYSTEM

[VK45DE]

RELATIONSHIP BETWEEN MIL, DTC, 1ST TRIP DTC AND DRIVING PATTERNS EXCEPT FOR "MISFIRE <EXHAUST QUALITY DETERIORATION>", "FUEL INJECTION SYSTEM"

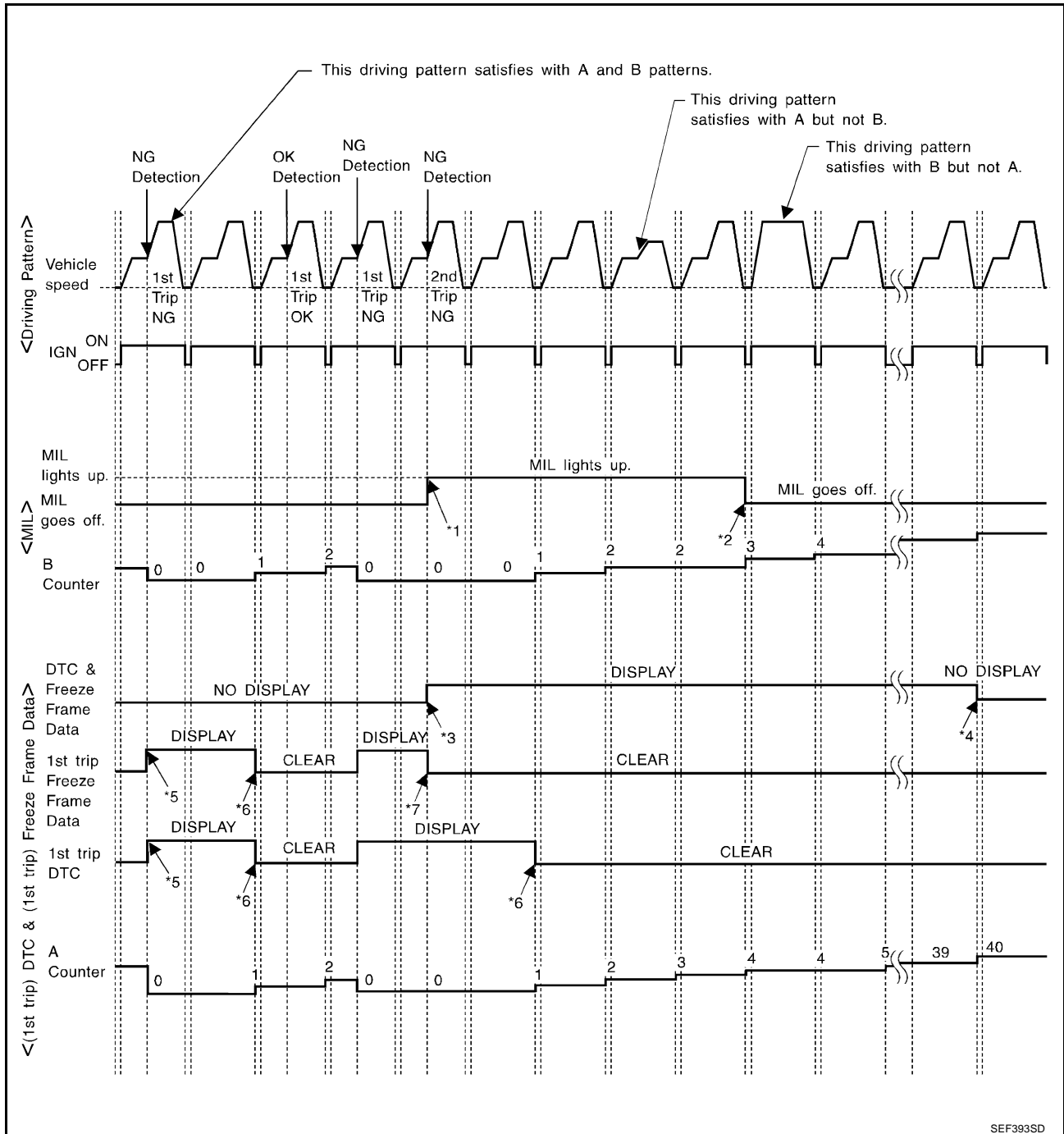

*1: When the same malfunction is detected in two consecutive trips, MIL will light up.

*2: MIL will go off after vehicle is driven 3 times (pattern B) without any malfunctions.

*3: When the same malfunction is detected in two consecutive trips, the DTC and the freeze frame data will be stored in ECM.

*4: The DTC and the freeze frame data will not be displayed any longer after vehicle is driven 40 times (pattern A) without the same malfunction. (The DTC and the freeze frame data still remain in ECM.)

*5: When a malfunction is detected for the first time, the 1st trip DTC and the 1st trip freeze frame data will be stored in ECM.

*6: 1st trip DTC will be cleared after vehicle is driven once (pattern B) without the same malfunction.

*7: When the same malfunction is detected in the 2nd trip, the 1st trip freeze frame data will be cleared.

EXPLANATION FOR DRIVING PATTERNS EXCEPT FOR "MISFIRE <EXHAUST QUALITY DETERIORATION>", "FUEL INJECTION SYSTEM"

<Driving Pattern A>

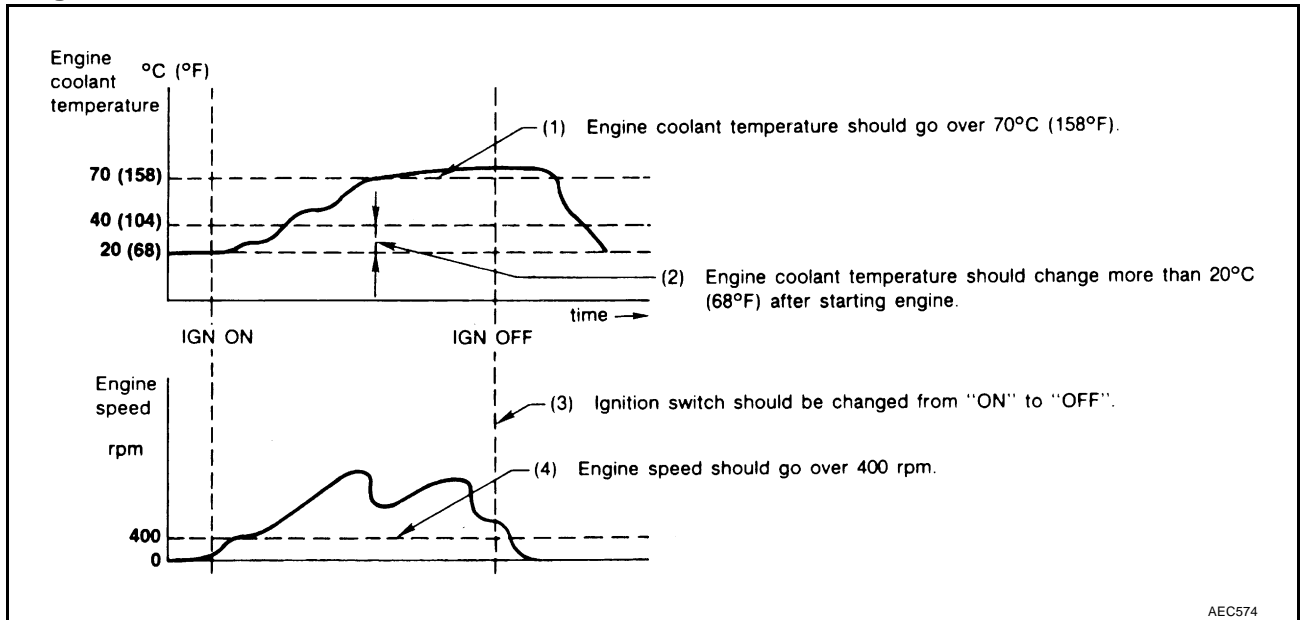

- The A counter will be cleared when the malfunction is detected regardless of (1) - (4).
- The A counter will be counted up when (1) - (4) are satisfied without the same malfunction.
- The DTC will not be displayed after the A counter reaches 40.

<Driving Pattern B>

Driving pattern B means the vehicle operation as follows:

All components and systems should be monitored at least once by the OBD system.

- The B counter will be cleared when the malfunction is detected once regardless of the driving pattern.
- The B counter will be counted up when driving pattern B is satisfied without any malfunctions.
- The MIL will go off when the B counter reaches 3 (*2 in OBD SYSTEM OPERATION CHART).

TROUBLE DIAGNOSIS

PFP:00004

Trouble Diagnosis Introduction
INTRODUCTION

ABS00BZO

The engine has an ECM to control major systems such as fuel control, ignition control, idle air control system, etc. The ECM accepts input signals from sensors and instantly drives actuators. It is essential that both input and output signals are proper and stable. At the same time, it is important that there are no malfunctions such as vacuum leaks, fouled spark plugs, or other malfunctions with the engine.

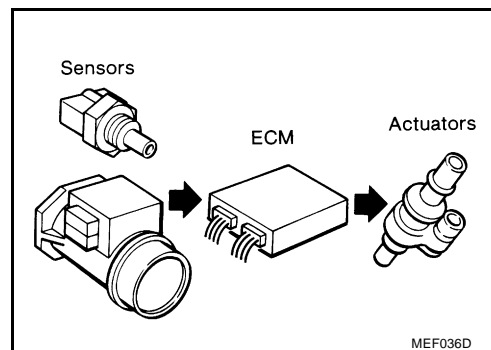

It is much more difficult to diagnose an incident that occurs intermittently rather than continuously. Most intermittent incidents are caused by poor electric connections or improper wiring. In this case, careful checking of suspected circuits may help prevent the replacement of good parts.

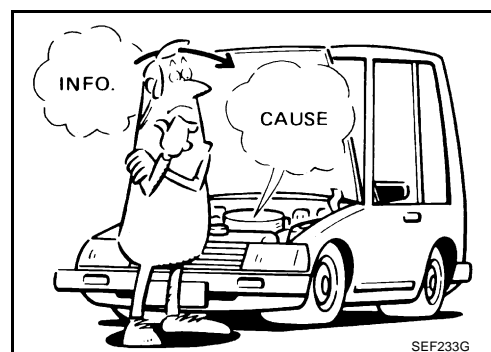

A visual check only may not find the cause of the incidents. A road test with CONSULT-II (or GST) or a circuit tester connected should be performed. Follow the Work Flow on [EC-727](#).

Before undertaking actual checks, take a few minutes to talk with a customer who approaches with a driveability complaint. The customer can supply good information about such incidents, especially intermittent ones. Find out what symptoms are present and under what conditions they occur. A Diagnostic Worksheet like the example on [EC-729](#) should be used.

Start your diagnosis by looking for conventional malfunctions first. This will help troubleshoot driveability malfunctions on an electronically controlled engine vehicle.

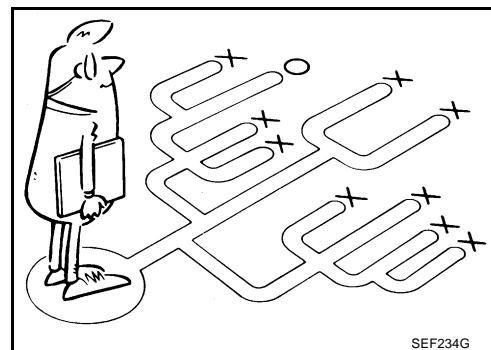

WORK FLOW

Flow Chart

A
EC
C
D
E
F
G
H
I
J
K
L
M

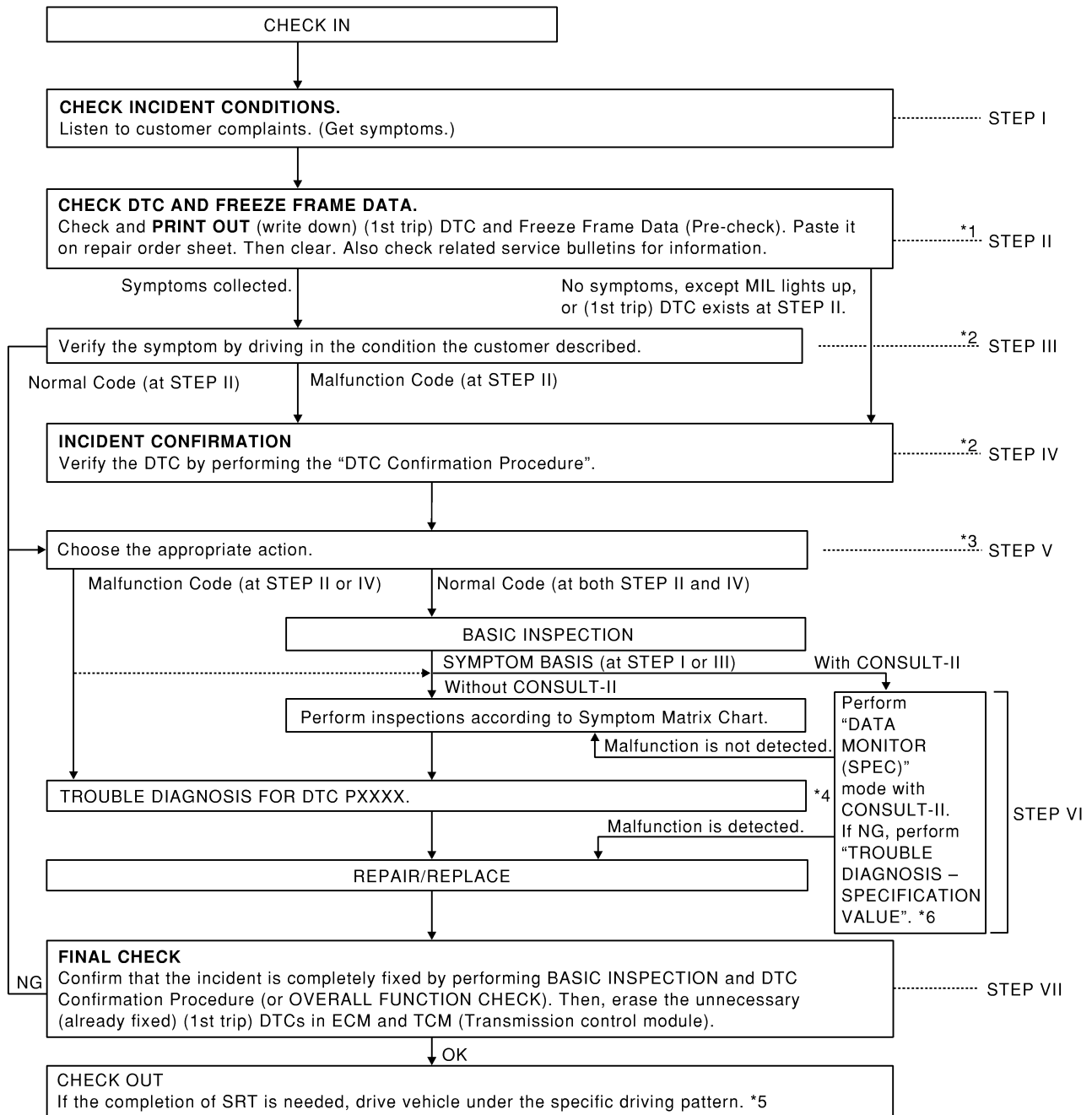

*1 If time data of "SELF-DIAG RESULTS" is other than [0] or [1t], perform [EC-784. "TROUBLE DIAGNOSIS FOR INTERMITTENT INCIDENT"](#).

*4 If malfunctioning part cannot be detected, perform [EC-784. "TROUBLE DIAGNOSIS FOR INTERMITTENT INCIDENT"](#).

*2 If the incident cannot be verified, perform [EC-784. "TROUBLE DIAGNOSIS FOR INTERMITTENT INCIDENT"](#).

*5 [EC-713](#)

*3 If the on board diagnostic system cannot be performed, check main power supply and ground circuit. Refer to [EC-785. "POWER SUPPLY AND GROUND CIRCUIT"](#).

*6 [EC-780](#)

PBIB1043E

TROUBLE DIAGNOSIS

[VK45DE]

Description for Work Flow

STEP	DESCRIPTION
STEP I	Get detailed information about the conditions and the environment when the incident/symptom occurred using the EC-728. "DIAGNOSTIC WORKSHEET" .
STEP II	Before confirming the concern, check and write down (print out using CONSULT-II or GST) the (1st trip) DTC and the (1st trip) freeze frame data, then erase the DTC and the data. (Refer to EC-715 .) The (1st trip) DTC and the (1st trip) freeze frame data can be used when duplicating the incident at STEP III & IV. If the incident cannot be verified, perform EC-784. "TROUBLE DIAGNOSIS FOR INTERMITTENT INCIDENT" . Study the relationship between the cause, specified by (1st trip) DTC, and the symptom described by the customer. (The Symptom Matrix Chart will be useful. See EC-738. "Symptom Matrix Chart" .) Also check related service bulletins for information.
STEP III	Try to confirm the symptom and under what conditions the incident occurs. The DIAGNOSTIC WORK SHEET and the freeze frame data are useful to verify the incident. Connect CONSULT-II to the vehicle in "DATA MONITOR (AUTO TRIG)" mode and check real time diagnosis results. If the incident cannot be verified, perform EC-784. "TROUBLE DIAGNOSIS FOR INTERMITTENT INCIDENT" . If the malfunction code is detected, skip STEP IV and perform STEP V.
STEP IV	Try to detect the (1st trip) DTC by driving in (or performing) the DTC Confirmation Procedure. Check and read the (1st trip) DTC and (1st trip) freeze frame data by using CONSULT-II or GST. During the (1st trip) DTC verification, be sure to connect CONSULT-II to the vehicle in "DATA MONITOR (AUTO TRIG)" mode and check real time diagnosis results. If the incident cannot be verified, perform EC-784. "TROUBLE DIAGNOSIS FOR INTERMITTENT INCIDENT" . In case the DTC Confirmation Procedure is not available, perform the Overall Function Check instead. The (1st trip) DTC cannot be displayed by this check, however, this simplified check is an effective alternative. The NG result of the Overall Function Check is the same as the (1st trip) DTC detection.
STEP V	Take the appropriate action based on the results of STEP I through IV. If the malfunction code is indicated, proceed to TROUBLE DIAGNOSIS FOR DTC PXXXX. If the normal code is indicated, proceed to the BASIC INSPECTION. (Refer to EC-733 .) Then perform inspections according to the Symptom Matrix Chart. (Refer to EC-738 .)
STEP VI	Identify where to begin diagnosis based on the relationship study between symptom and possible causes. Inspect the system for mechanical binding, loose connectors or wiring damage using (tracing) "Harness Layouts". Gently shake the related connectors, components or wiring harness with CONSULT-II set in "DATA MONITOR (AUTO TRIG)" mode. Check the voltage of the related ECM terminals or monitor the output data from the related sensors with CONSULT-II. Refer to EC-750 , EC-775 . The Diagnostic Procedure in EC section contains a description based on open circuit inspection. A short circuit inspection is also required for the circuit check in the Diagnostic Procedure. For details, refer to "Circuit Inspection" in GI-27. "How to Perform Efficient Diagnosis for an Electrical Incident" . Repair or replace the malfunction parts. If malfunctioning part cannot be detected, perform EC-784. "TROUBLE DIAGNOSIS FOR INTERMITTENT INCIDENT" .
STEP VII	Once you have repaired the circuit or replaced a component, you need to run the engine in the same conditions and circumstances which resulted in the customer's initial complaint. Perform the DTC Confirmation Procedure and confirm the normal code [DTC No. P0000] is detected. If the incident is still detected in the final check, perform STEP VI by using a method different from the previous one. Before returning the vehicle to the customer, be sure to erase the unnecessary (already fixed) (1st trip) DTC in ECM and TCM (Transmission control module). (Refer to EC-715. "HOW TO ERASE EMISSION-RELATED DIAGNOSTIC INFORMATION" and AT-39. "HOW TO ERASE DTC" .)

DIAGNOSTIC WORKSHEET

Description

There are many operating conditions that lead to the malfunction of engine components. A good grasp of such conditions can make troubleshooting faster and more accurate.

In general, each customer feels differently about an incident. It is important to fully understand the symptoms or conditions for a customer complaint.

Utilize a diagnostic worksheet like the one on the next page in order to organize all the information for troubleshooting.

Some conditions may cause the MIL to come on steady or blink and DTC to be detected. Examples:

- Vehicle ran out of fuel, which caused the engine to misfire.

KEY POINTS

WHAT Vehicle & engine model
WHEN Date, Frequencies
WHERE..... Road conditions
HOW Operating conditions,
 Weather conditions,
 Symptoms

SEF907L

TROUBLE DIAGNOSIS

[VK45DE]

- Fuel filler cap was left off or incorrectly screwed on, allowing fuel to evaporate into the atmosphere.

Worksheet Sample

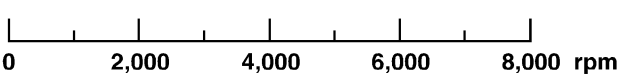
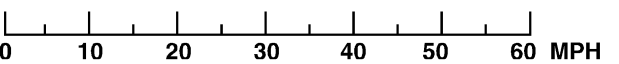
Customer name MR/MS		Model & Year	VIN
Engine #		Trans.	Mileage
Incident Date		Manuf. Date	In Service Date
Fuel and fuel filler cap		<input type="checkbox"/> Vehicle ran out of fuel causing misfire <input type="checkbox"/> Fuel filler cap was left off or incorrectly screwed on.	
Symptoms	<input type="checkbox"/> Startability	<input type="checkbox"/> Impossible to start <input type="checkbox"/> No combustion <input type="checkbox"/> Partial combustion <input type="checkbox"/> Partial combustion affected by throttle position <input type="checkbox"/> Partial combustion NOT affected by throttle position <input type="checkbox"/> Possible but hard to start <input type="checkbox"/> Others []	
	<input type="checkbox"/> Idling	<input type="checkbox"/> No fast idle <input type="checkbox"/> Unstable <input type="checkbox"/> High idle <input type="checkbox"/> Low idle <input type="checkbox"/> Others []	
	<input type="checkbox"/> Driveability	<input type="checkbox"/> Stumble <input type="checkbox"/> Surge <input type="checkbox"/> Knock <input type="checkbox"/> Lack of power <input type="checkbox"/> Intake backfire <input type="checkbox"/> Exhaust backfire <input type="checkbox"/> Others []	
	<input type="checkbox"/> Engine stall	<input type="checkbox"/> At the time of start <input type="checkbox"/> While idling <input type="checkbox"/> While accelerating <input type="checkbox"/> While decelerating <input type="checkbox"/> Just after stopping <input type="checkbox"/> While loading	
Incident occurrence		<input type="checkbox"/> Just after delivery <input type="checkbox"/> Recently <input type="checkbox"/> In the morning <input type="checkbox"/> At night <input type="checkbox"/> In the daytime	
Frequency		<input type="checkbox"/> All the time <input type="checkbox"/> Under certain conditions <input type="checkbox"/> Sometimes	
Weather conditions		<input type="checkbox"/> Not affected	
	Weather	<input type="checkbox"/> Fine <input type="checkbox"/> Raining <input type="checkbox"/> Snowing <input type="checkbox"/> Others []	
	Temperature	<input type="checkbox"/> Hot <input type="checkbox"/> Warm <input type="checkbox"/> Cool <input type="checkbox"/> Cold <input type="checkbox"/> Humid °F	
Engine conditions		<input type="checkbox"/> Cold <input type="checkbox"/> During warm-up <input type="checkbox"/> After warm-up Engine speed 	
Road conditions		<input type="checkbox"/> In town <input type="checkbox"/> In suburbs <input type="checkbox"/> Highway <input type="checkbox"/> Off road (up/down)	
Driving conditions		<input type="checkbox"/> Not affected <input type="checkbox"/> At starting <input type="checkbox"/> While idling <input type="checkbox"/> At racing <input type="checkbox"/> While accelerating <input type="checkbox"/> While cruising <input type="checkbox"/> While decelerating <input type="checkbox"/> While turning (RH/LH) Vehicle speed 	
Malfunction indicator lamp		<input type="checkbox"/> Turned on <input type="checkbox"/> Not turned on	

MTBL0017
ABS00BZP

DTC Inspection Priority Chart

If some DTCs are displayed at the same time, perform inspections one by one based on the following priority chart.

NOTE:

If DTC U1000 and/or U1001 is displayed with other DTC, first perform the trouble diagnosis for DTC U1000, U1001. Refer to [EC-792](#).

TROUBLE DIAGNOSIS

[VK45DE]

Priority	Detected items (DTC)
1	<ul style="list-style-type: none">● U1000 U1001 CAN communication line● P0101 P0102 P0103 P1102 Mass air flow sensor● P0112 P0113 P0127 Intake air temperature sensor● P0117 P0118 P0125 Engine coolant temperature sensor● P0122 P0123 P0222 P0223 P1225 P1226 P2135 Throttle position sensor● P0128 Thermostat function● P0181 P0182 P0183 Fuel tank temperature sensor● P0327 P0328 P0332 P0333 Knock sensor● P0335 Crankshaft position sensor (POS)● P0340 Camshaft position sensor (PHASE)● P0460 P0461 P0462 P0463 Fuel level sensor● P0500 Vehicle speed sensor● P0605 ECM● P0705 Park/Neutral position (PNP) switch● P1229 Sensor power supply● P1610 - P1615 NATS● P1706 Park/Neutral position (PNP) switch● P2122 P2123 P2127 P2128 P2138 Accelerator pedal position sensor

TROUBLE DIAGNOSIS

[VK45DE]

Priority	Detected items (DTC)	
2	<ul style="list-style-type: none"> ● P0031 P0032 P0051 P0052 Heated oxygen sensor 1 heater ● P0037 P0038 P0057 P0058 Heated oxygen sensor 2 heater ● P0132 P0133 P0134 P0152 P0153 P0154 P1143 P1144 P1163 P1164 Heated oxygen sensor 1 ● P0138 P0139 P0158 P0159 P1146 P1147 P1166 P1167 Heated oxygen sensor 2 ● P0441 EVAP control system purge flow monitoring ● P0444 P0445 P1444 EVAP canister purge volume control solenoid valve ● P0447 P1446 EVAP canister vent control valve ● P0451 P0452 P0453 EVAP control system pressure sensor ● P0550 Power steering pressure sensor ● P0710 P0720 P0740 P0744 P0745 P1716 P1720 P1730 P1752 P1754 P1757 P1759 P1762 P1764 P1767 P1769 P1772 P1774 A/T related sensors, solenoid valves and switches ● P1065 ECM power supply ● P1111 P1136 Intake valve timing control solenoid valve ● P1122 Electric throttle control function ● P1124 P1126 P1128 Electric throttle control actuator ● P1140 P1145 Intake valve timing control position sensor ● P1217 Engine over temperature (OVERHEAT) ● P1805 Brake switch 	<p>A</p> <p>EC</p> <p>C</p> <p>D</p> <p>E</p> <p>F</p> <p>G</p>
3	<ul style="list-style-type: none"> ● P0011 P0021 Intake valve timing control ● P0171 P0172 P0174 P0175 Fuel injection system function ● P0300 - P0308 Misfire ● P0420 P0430 Three way catalyst function ● P0442 P0456 EVAP control system (SMALL LEAK, VERY SMALL LEAK) ● P0455 EVAP control system (GROSS LEAK) ● P0506 P0507 Idle speed control system ● P1121 Electric throttle control actuator ● P1148 P1168 Closed loop control ● P1211 TCS control unit ● P1212 TCS communication line ● P1564 ICC steering switch/ASCD steering switch ● P1568 ICC command value ● P1572 ICC brake switch/ASCD brake switch ● P1574 ICC vehicle speed sensor/ASCD vehicle speed sensor ● P1780 Shift change signal 	<p>H</p> <p>I</p> <p>J</p> <p>K</p> <p>L</p> <p>M</p>

Fail-safe Chart

ABS00BZO

When the DTC listed below is detected, the ECM enters fail-safe mode and the MIL lights up.

DTC No.	Detected items	Engine operating condition in fail-safe mode
P0102 P0103 P1102	Mass air flow sensor circuit	Engine speed will not rise more than 2,400 rpm due to the fuel cut.

TROUBLE DIAGNOSIS

[VK45DE]

DTC No.	Detected items	Engine operating condition in fail-safe mode	
P0117 P0118	Engine coolant temperature sensor circuit	Engine coolant temperature will be determined by ECM based on the time after turning ignition switch ON or START. CONSULT-II displays the engine coolant temperature decided by ECM.	
		Condition	Engine coolant temperature decided (CONSULT-II display)
		Just as ignition switch is turned ON or START	40°C (104°F)
		More than approx. 4 minutes after ignition ON or START	80°C (176°F)
		Except as shown above	40 - 80°C (104 - 176°F) (Depends on the time)
		When the fail-safe system for engine coolant temperature sensor is activated, the cooling fan operates while engine is running.	
P0122 P0123 P0222 P0223 P2135	Throttle position sensor	The ECM controls the electric throttle control actuator in regulating the throttle opening in order for the idle position to be within +10 degrees. The ECM regulates the opening speed of the throttle valve to be slower than the normal condition. So, the acceleration will be poor.	
P1121	Electric throttle control actuator	(When electric throttle control actuator does not function properly due to the return spring malfunction:) ECM controls the electric throttle actuator by regulating the throttle opening around the idle position. The engine speed will not rise more than 2,000 rpm.	
		(When throttle valve opening angle in fail-safe mode is not in specified range:) ECM controls the electric throttle control actuator by regulating the throttle opening to 20 degrees or less.	
		(When ECM detects the throttle valve is stuck open:) While the vehicle is driving, it slows down gradually by fuel cut. After the vehicle stops, the engine stalls. The engine can restart in N or P position, and engine speed will not exceed 1,000 rpm or more.	
P1122	Electric throttle control function	ECM stops the electric throttle control actuator control, throttle valve is maintained at a fixed opening (approx. 5 degrees) by the return spring.	
P1124 P1126	Throttle control motor relay	ECM stops the electric throttle control actuator control, throttle valve is maintained at a fixed opening (approx. 5 degrees) by the return spring.	
P1128	Throttle control motor	ECM stops the electric throttle control actuator control, throttle valve is maintained at a fixed opening (approx. 5 degrees) by the return spring.	
P1229	Sensor power supply	ECM stops the electric throttle control actuator control, throttle valve is maintained at a fixed opening (approx. 5 degrees) by the return spring.	
P2122 P2123 P2127 P2128 P2138	Accelerator pedal position sensor	The ECM controls the electric throttle control actuator in regulating the throttle opening in order for the idle position to be within +10 degrees. The ECM regulates the opening speed of the throttle valve to be slower than the normal condition. So, the acceleration will be poor.	

- When there is an open circuit on MIL circuit, the ECM cannot warn the driver by lighting up MIL when there is malfunction on engine control system.
Therefore, when electrical controlled throttle and part of ECM related diagnoses are continuously detected as NG for 5 trips, ECM warns the driver that engine control system malfunctions and MIL circuit is open by means of operating fail-safe function.
The fail-safe function also operates when above diagnoses except MIL circuit are detected and demands the driver to repair the malfunction.

Engine operating condition in fail-safe mode	Engine speed will not rise more than 2,500 rpm due to the fuel cut
--	--

Basic Inspection**1. INSPECTION START**

1. Check service records for any recent repairs that may indicate a related malfunction, or a current need for scheduled maintenance.
2. Open engine hood and check the following:
 - Harness connectors for improper connections
 - Wiring harness for improper connections, pinches and cut
 - Vacuum hoses for splits, kinks and improper connections
 - Hoses and ducts for leaks
 - Air cleaner clogging
 - Gasket
3. Confirm that electrical or mechanical loads are not applied.
 - Head lamp switch is OFF.
 - Air conditioner switch is OFF.
 - Rear window defogger switch is OFF.
 - Steering wheel is in the straight-ahead position, etc.
4. Start engine and warm it up until engine coolant temperature indicator points the middle of gauge. Ensure engine stays below 1,000 rpm.

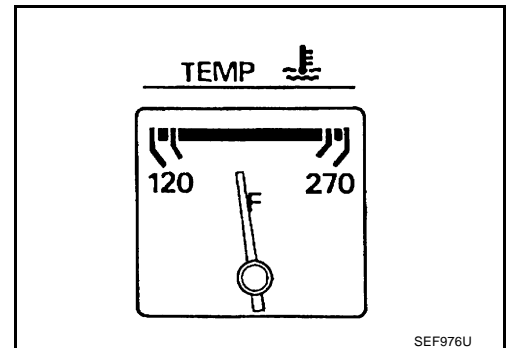
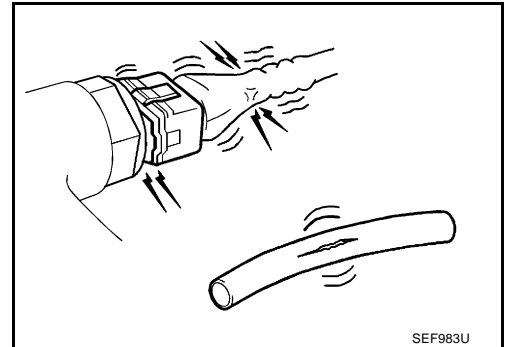

5. Run engine at about 2,000 rpm for about 2 minutes under no load.
6. Make sure that no DTC is displayed with CONSULT-II or GST.

OK or NG

- OK >> GO TO 3.
 NG >> GO TO 2.

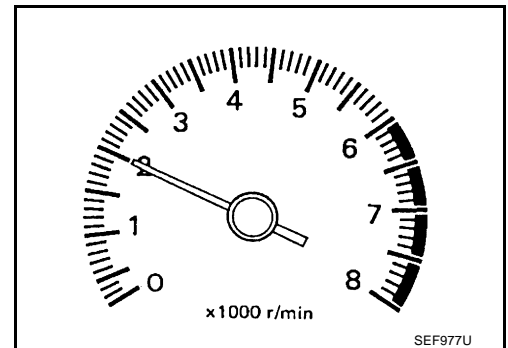
**2. REPAIR OR REPLACE**

Repair or replace components as necessary according to corresponding Diagnostic Procedure.

>> GO TO 3.

A
 EC
 C
 D
 E
 F
 G
 H
 I
 J
 K
 L
 M

3. CHECK TARGET IDLE SPEED

④ With CONSULT-II

1. Run engine at about 2,000 rpm for about 2 minutes under no load.
2. Rev engine (2,000 to 3,000 rpm) two or three times under no load, then run engine at idle speed for about 1 minute.

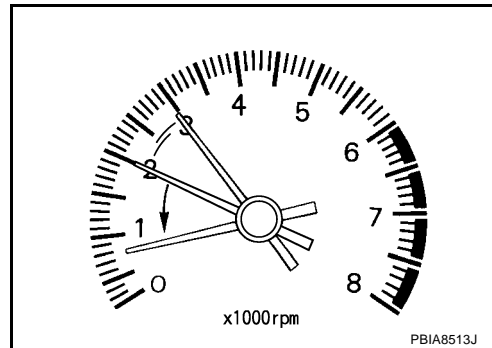

3. Read idle speed in "DATA MONITOR" mode with CONSULT-II.
650 ± 50 rpm (in P or N position)

DATA MONITOR	
MONITOR	NO DTC
ENG SPEED	XXX rpm

SEF058Y

⊗ Without CONSULT-II

1. Run engine at about 2,000 rpm for about 2 minutes under no load.
2. Rev engine (2,000 to 3,000 rpm) two or three times under no load, then run engine at idle speed for about 1 minute.
3. Check idle speed.

650 ± 50 rpm (in P or N position)

OK or NG

- OK >> GO TO 9.
NG >> GO TO 4.

4. PERFORM ACCELERATOR PEDAL RELEASED POSITION LEARNING

1. Stop engine.
2. Perform [EC-698, "Accelerator Pedal Released Position Learning"](#) .

>> GO TO 5.

5. PERFORM THROTTLE VALVE CLOSED POSITION LEARNING

Perform [EC-698, "Throttle Valve Closed Position Learning"](#) .

>> GO TO 6.

6. PERFORM IDLE AIR VOLUME LEARNING

Refer to [EC-698, "Idle Air Volume Learning"](#) .

Is Idle Air Volume Learning carried out successfully?

Yes or No

Yes >> GO TO 7.

No >> 1. Follow the instruction of Idle Air Volume Learning.
2. GO TO 4.

7. CHECK TARGET IDLE SPEED AGAIN

(P) With CONSULT-II

1. Start engine and warm it up to normal operating temperature.
2. Read idle speed in "DATA MONITOR" mode with CONSULT-II.

650 ± 50 rpm (in P or N position)

(X) Without CONSULT-II

1. Start engine and warm it up to normal operating temperature.
2. Check idle speed.

650 ± 50 rpm (in P or N position)

OK or NG

OK >> GO TO 10.

NG >> GO TO 8.

DATA MONITOR	
MONITOR	NO DTC
ENG SPEED	XXX rpm

SEP058Y

8. DETECT MALFUNCTIONING PART

Check the following.

- Check camshaft position sensor (PHASE) and circuit. Refer to [EC-966](#) .
- Check crankshaft position sensor (POS) and circuit. Refer to [EC-960](#) .

OK or NG

OK >> GO TO 9.

NG >> 1. Repair or replace.
2. GO TO 4.

9. CHECK ECM FUNCTION

1. Substitute another known-good ECM to check ECM function. (ECM may be the cause of an incident, but this is a rare case.)
2. Perform initialization of IVIS (NATS) system and registration of all IVIS (NATS) ignition key IDs. Refer to [EC-717, "IVIS \(Infiniti Vehicle Immobilizer System — NATS\)"](#) .

>> GO TO 4.

10. CHECK IGNITION TIMING

1. Run engine at idle.
2. Check ignition timing with a timing light.

12 ± 5° BTDC (in P or N position)

OK or NG

- OK >> **INSPECTION END**
 NG >> GO TO 11.

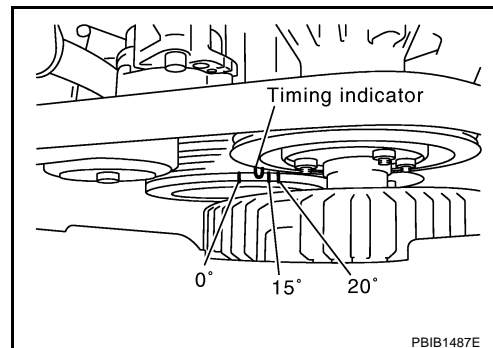

11. PERFORM ACCELERATOR PEDAL RELEASED POSITION LEARNING

1. Stop engine.
2. Perform [EC-698, "Accelerator Pedal Released Position Learning"](#) .

>> GO TO 12.

12. PERFORM THROTTLE VALVE CLOSED POSITION LEARNING

Perform [EC-698, "Throttle Valve Closed Position Learning"](#) .

>> GO TO 13.

13. PERFORM IDLE AIR VOLUME LEARNING

Refer to [EC-698, "Idle Air Volume Learning"](#) .

Is Idle Air Volume Learning carried out successfully?

Yes or No

- Yes >> GO TO 14.
 No >> 1. Follow the instruction of Idle Air Volume Learning.
 2. GO TO 4.

14. CHECK TARGET IDLE SPEED AGAIN

 **With CONSULT-II**

1. Start engine and warm it up to normal operating temperature.
2. Read idle speed in "DATA MONITOR" mode with CONSULT-II.

650 ± 50 rpm (in P or N position)

 **Without CONSULT-II**

1. Start engine and warm it up to normal operating temperature.
2. Check idle speed.

650 ± 50 rpm (in P or N position)

OK or NG

- OK >> GO TO 15.
 NG >> GO TO 17.

DATA MONITOR	
MONITOR	NO DTC
ENG SPEED	XXX rpm

SEF058Y

15. CHECK IGNITION TIMING AGAIN

1. Run engine at idle.
2. Check ignition timing with a timing light.

12 ± 5° BTDC (in P or N position)

OK or NG

- OK >> **INSPECTION END**
 NG >> GO TO 16.

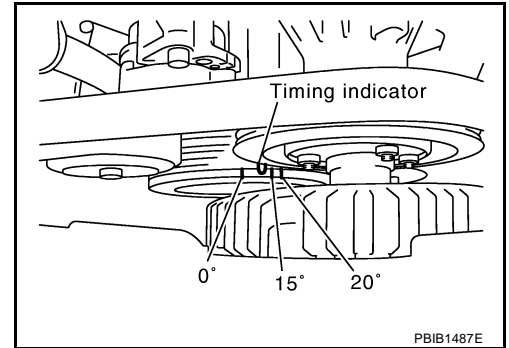
**16. CHECK TIMING CHAIN INSTALLATION**

Check timing chain installation. Refer to [EM-196, "TIMING CHAIN"](#) .

OK or NG

- OK >> GO TO 17.
 NG >> 1. Repair the timing chain installation.
 2. GO TO 4.

17. DETECT MALFUNCTIONING PART

Check the following.

- Check camshaft position sensor (PHASE) and circuit. Refer to [EC-966](#) .
- Check crankshaft position sensor (POS) and circuit. Refer to [EC-960](#) .

OK or NG

- OK >> GO TO 18.
 NG >> 1. Repair or replace.
 2. GO TO 4.

18. CHECK ECM FUNCTION

1. Substitute another known-good ECM to check ECM function. (ECM may be the cause of an incident, but this is a rare case.)
2. Perform initialization of IVIS (NATS) system and registration of all IVIS (NATS) ignition key IDs. Refer to [EC-717, "IVIS \(Infiniti Vehicle Immobilizer System — NATS\)"](#) .

>> GO TO 4.

TROUBLE DIAGNOSIS

[VK45DE]

Symptom Matrix Chart SYSTEM — BASIC ENGINE CONTROL SYSTEM

ABS00BZS

		SYMPTOM												Reference page	
		HARD/NO START/RESTART (EXCP. HA)	ENGINE STALL	HESITATION/SURGING/FLAT SPOT	SPARK KNOCK/DETONATION	LACK OF POWER/POOR ACCELERATION	HIGH IDLE/LOW IDLE	ROUGH IDLE/HUNTING	IDLING VIBRATION	SLOW/NO RETURN TO IDLE	OVERHEATS/WATER TEMPERATURE HIGH	EXCESSIVE FUEL CONSUMPTION	EXCESSIVE OIL CONSUMPTION		BATTERY DEAD (UNDER CHARGE)
Warranty symptom code		AA	AB	AC	AD	AE	AF	AG	AH	AJ	AK	AL	AM	HA	
Fuel	Fuel pump circuit	1	1	2	3	2		2	2			3		2	EC-1280
	Fuel pressure regulator system	3	3	4	4	4	4	4	4	4		4			EC-700
	Injector circuit	1	1	2	3	2		2	2			2			EC-1274
	Evaporative emission system	3	3	4	4	4	4	4	4	4		4			EC-1320
Air	Positive crankcase ventilation system	3	3	4	4	4	4	4	4	4		4	1		EC-1332
	Incorrect idle speed adjustment						1	1	1	1		1			EC-687
	Electric throttle control actuator	1	1	2	3	3	2	2	2	2		2		2	EC-1077 , EC-1079
Ignition	Incorrect ignition timing adjustment	3	3	1	1	1		1	1			1			EC-687
	Ignition circuit	1	1	2	2	2		2	2			2			EC-1262
Power supply and ground circuit		2	2	3	3	3		3	3		2	3			EC-785
Mass air flow sensor circuit		1			2										EC-822 , EC-830 , EC-1064
Engine coolant temperature sensor circuit							3			3					EC-842 , EC-855
Heated oxygen sensor 1 circuit			1	2	3	2		2	2			2			EC-863 , EC-872 , EC-884 , EC-1103 , EC-1109
Throttle position sensor circuit							2			2					EC-848 , EC-942 , EC-1152 , EC-1154 , EC-1156 , EC-1239
Accelerator pedal position sensor circuit				3	2	1									EC-1225 , EC-1232 , EC-1246
Knock sensor circuit				2								3			EC-955
Crankshaft position sensor (POS) circuit		2	2												EC-960
Camshaft position sensor (PHASE) circuit		3	2												EC-966
Vehicle speed signal circuit			2	3		3						3			EC-1046

TROUBLE DIAGNOSIS

[VK45DE]

	SYMPTOM													Reference page
	HARD/NO START/RESTART (EXCP. HA)	ENGINE STALL	HESITATION/SURGING/FLAT SPOT	SPARK KNOCK/DETONATION	LACK OF POWER/POOR ACCELERATION	HIGH IDLE/LOW IDLE	ROUGH IDLE/HUNTING	IDLING VIBRATION	SLOW/NO RETURN TO IDLE	OVERHEATS/WATER TEMPERATURE HIGH	EXCESSIVE FUEL CONSUMPTION	EXCESSIVE OIL CONSUMPTION	BATTERY DEAD (UNDER CHARGE)	
Warranty symptom code	AA	AB	AC	AD	AE	AF	AG	AH	AJ	AK	AL	AM	HA	
Power steering pressure sensor circuit		2					3	3						EC-1052
ECM	2	2	3	3	3	3	3	3	3	3	3			EC-1057 , EC-1060
Intake valve timing control solenoid valve circuit		3	2		1	3	2	2	3		3			EC-1070
PNP switch circuit			3		3		3	3			3			EC-1211
Refrigerant pressure sensor circuit		2				3			3		4			EC-1287
Electrical load signal circuit							3							EC-1292
Air conditioner circuit	2	2	3	3	3	3	3	3	3		3		2	ATC-40
VIAS control solenoid valve circuit					1									EC-1254
ABS actuator and electric unit (control unit)			4											EC-1140

1 - 6: The numbers refer to the order of inspection.
(continued on next page)

A
EC
C
D
E
F
G
H
I
J
K
L
M

TROUBLE DIAGNOSIS

[VK45DE]

SYSTEM — ENGINE MECHANICAL & OTHER

		SYMPTOM													Reference page											
		HARD/NO START/RESTART (EXCP. HA)	ENGINE STALL	HESITATION/SURGING/FLAT SPOT	SPARK KNOCK/DETONATION	LACK OF POWER/POOR ACCELERATION	HIGH IDLE/LOW IDLE	ROUGH IDLE/HUNTING	IDLING VIBRATION	SLOW/NO RETURN TO IDLE	OVERHEATS/WATER TEMPERATURE HIGH	EXCESSIVE FUEL CONSUMPTION	EXCESSIVE OIL CONSUMPTION	BATTERY DEAD (UNDER CHARGE)												
Warranty symptom code		AA	AB	AC	AD	AE	AF	AG	AH	AJ	AK	AL	AM	HA												
Fuel	Fuel tank	5	5												FL-10											
	Fuel piping			5	5	5		5	5			5			EM-188											
	Vapor lock															—										
	Valve deposit															—										
	Poor fuel (Heavy weight gasoline, Low octane)	5		5	5	5		5	5			5			—											
Air	Air duct		5	5	5	5	5	5	5	5	5	5	5	5	EM-172											
	Air cleaner														EM-172											
	Air leakage from air duct (Mass air flow sensor — electric throttle control actuator)	5																								EM-172
	Electric throttle control actuator																									EM-174
	Air leakage from intake manifold/Collector/Gasket														EM-174											
Cranking	Battery	1	1	1	1	1	1	1	1	1	1	1	1	1	SC-4											
	Generator circuit																									
	Starter circuit	3										1			SC-10											
	Signal plate	6													EM-240											
	PNP switch	4													AT-112											
Engine	Cylinder head	5	5	5	5	5	5	5	5	5	5	5	3	3	EM-224											
	Cylinder head gasket																									
	Cylinder block																									
	Piston												4													
	Piston ring	6	6	6	6	6	6	6	6	6	6	6	6	6	EM-240											
	Connecting rod																									
	Bearing																									
Crankshaft																										
Valve mechanism	Timing chain														EM-196											
	Camshaft														EM-208											
	Intake valve timing control	5	5	5	5	5	5	5	5	5	5	5	5	EM-196												
	Intake valve																									
	Exhaust valve												3	EM-196												

TROUBLE DIAGNOSIS

[VK45DE]

		SYMPTOM												Reference page	
		HARD/NO START/RESTART (EXCP. HA)	ENGINE STALL	HESITATION/SURGING/FLAT SPOT	SPARK KNOCK/DETONATION	LACK OF POWER/POOR ACCELERATION	HIGH IDLE/LOW IDLE	ROUGH IDLE/HUNTING	IDLING VIBRATION	SLOW/NO RETURN TO IDLE	OVERHEATS/WATER TEMPERATURE HIGH	EXCESSIVE FUEL CONSUMPTION	EXCESSIVE OIL CONSUMPTION		BATTERY DEAD (UNDER CHARGE)
Warranty symptom code		AA	AB	AC	AD	AE	AF	AG	AH	AJ	AK	AL	AM	HA	
Exhaust	Exhaust manifold/Tube/Muffler/Gasket	5	5	5	5	5		5	5			5			EM-178 , EX-3
	Three way catalyst														
Lubrica-tion	Oil pan/Oil strainer/Oil pump/Oil filter/Oil gallery/Oil cooler	5	5	5	5	5		5	5			5			EM-181 , LU-31 , LU-28 , LU-29
	Oil level (Low)/Filthy oil														LU-25
Cooling	Radiator/Hose/Radiator filler cap														CO-39 , CO-43
	Thermostat								5						CO-51
	Water pump	5	5	5	5	5		5	5		4	5			CO-49
	Water gallery														CO-34
	Cooling fan														CO-47
	Coolant level (Low)/Contami-nated coolant									5					CO-36
IVIS (INFINITI Vehicle Immobilizer System — NATS)		1	1												EC-717 or BL-206

1 - 6: The numbers refer to the order of inspection.

A
EC
C
D
E
F
G
H
I
J
K
L
M

Engine Control Component Parts Location

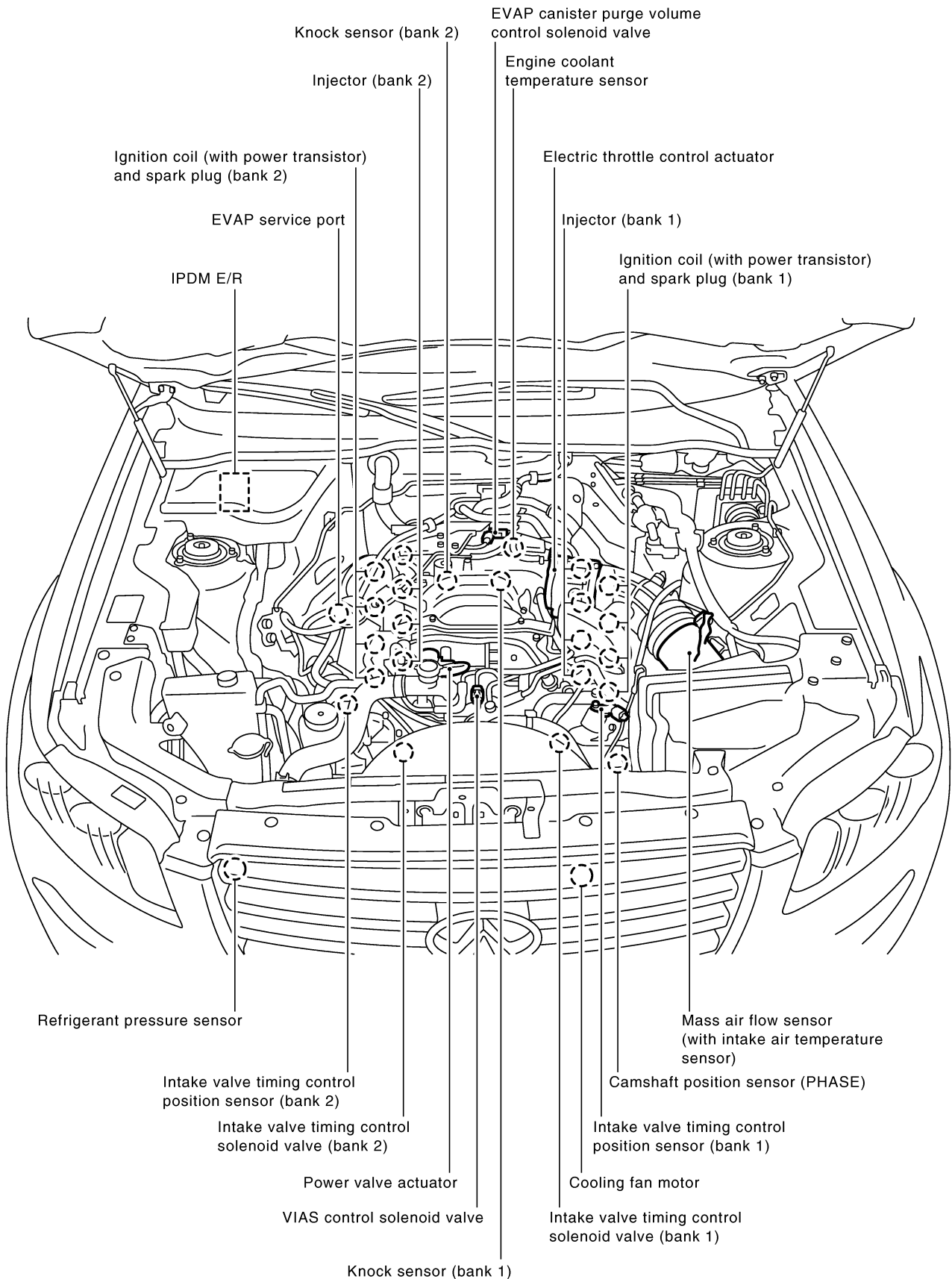

TROUBLE DIAGNOSIS

[VK45DE]

A
EC
C
D
E
F
G
H
I
J
K
L
M

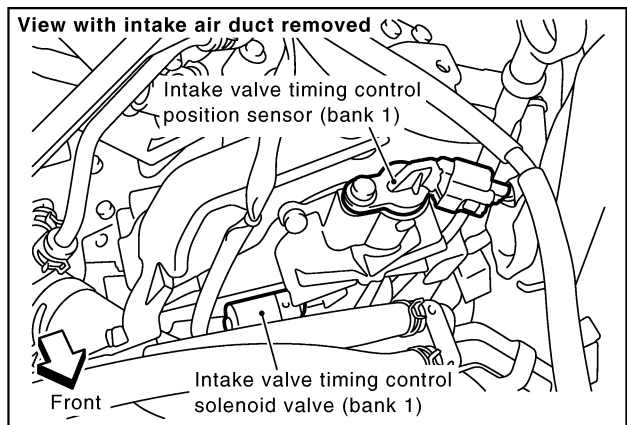
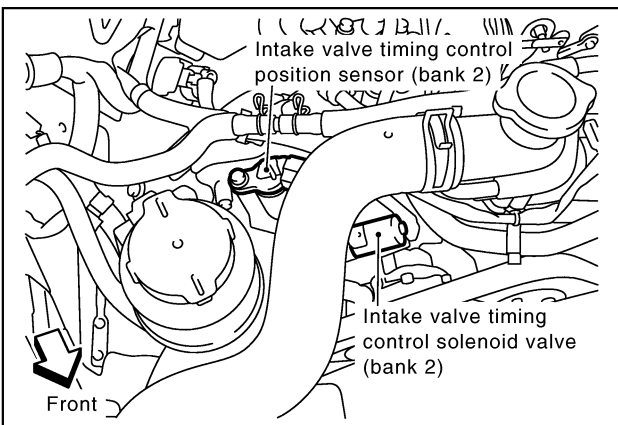
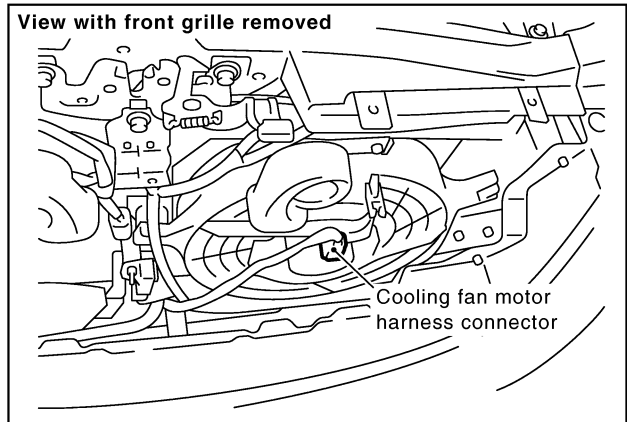
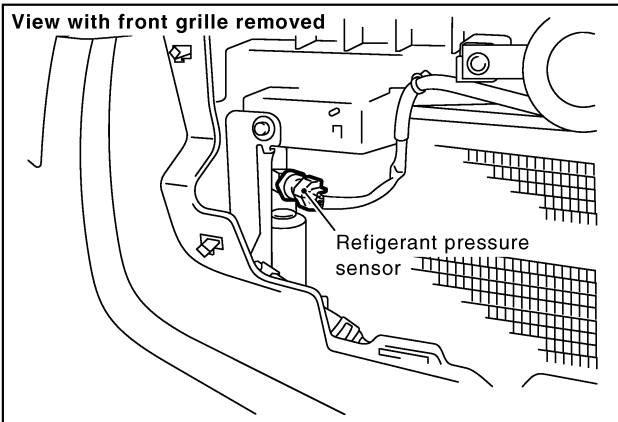
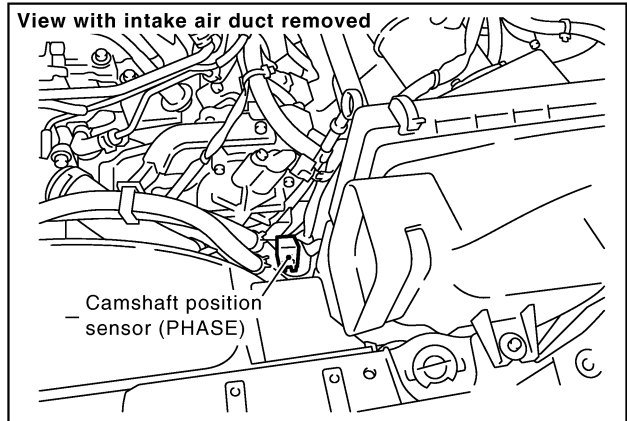
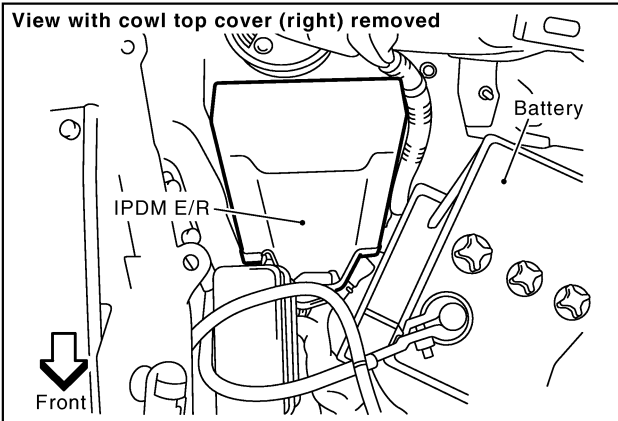
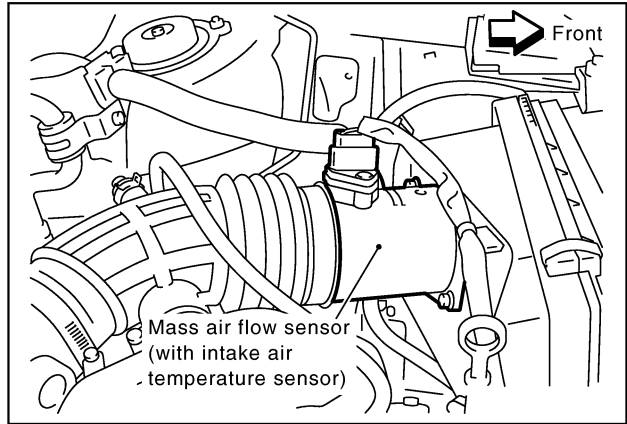
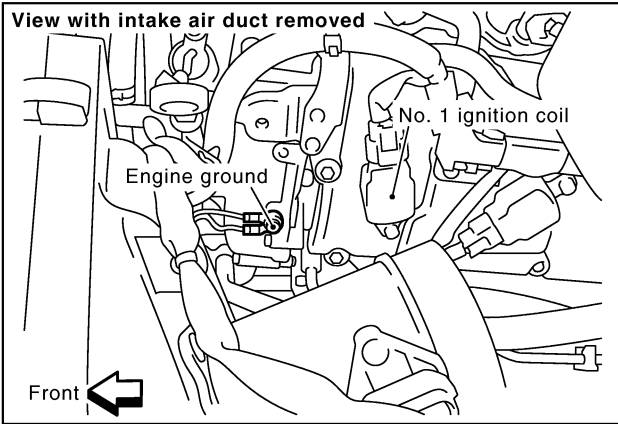

PBIB1544E

TROUBLE DIAGNOSIS

[VK45DE]

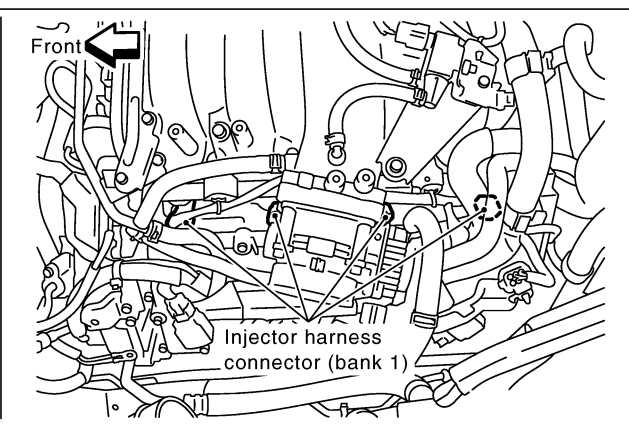
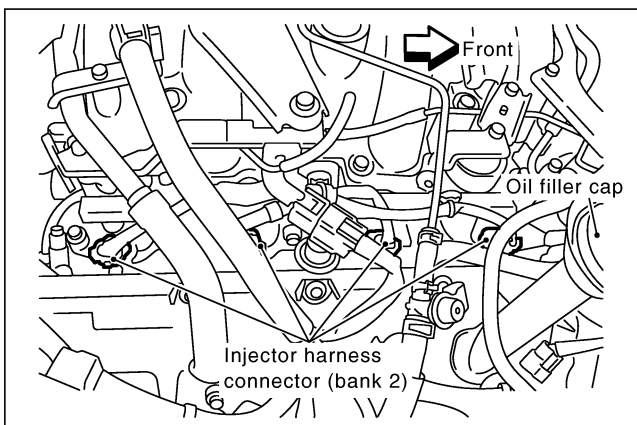
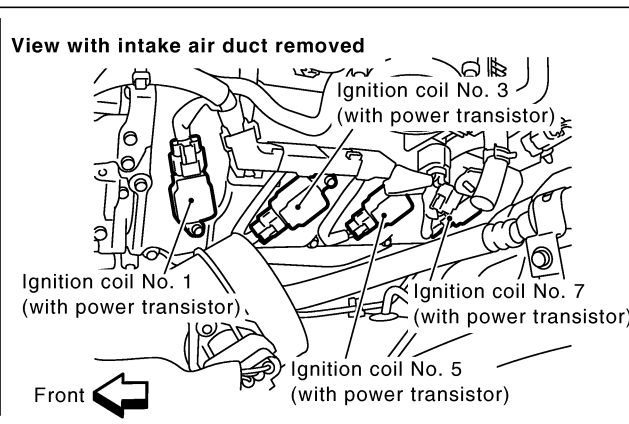
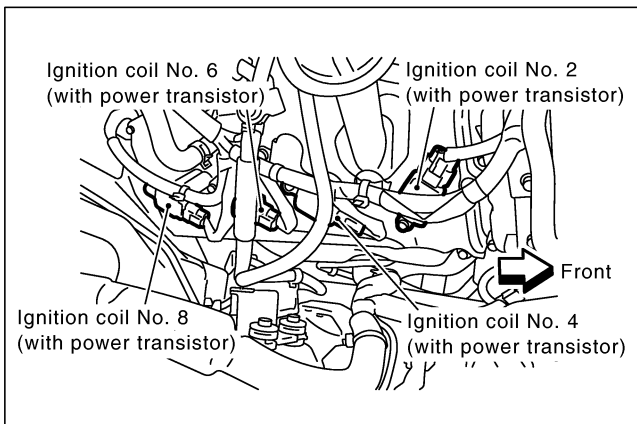
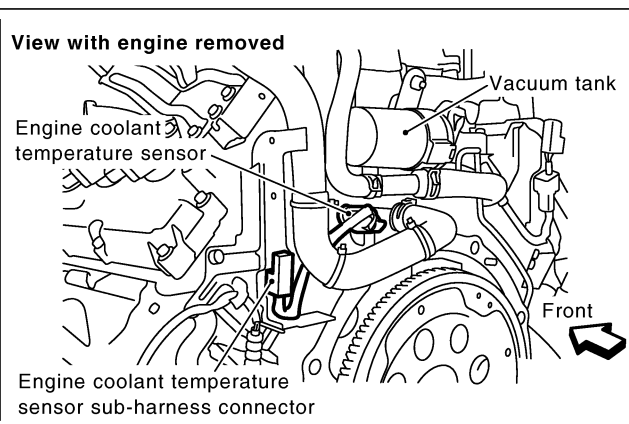
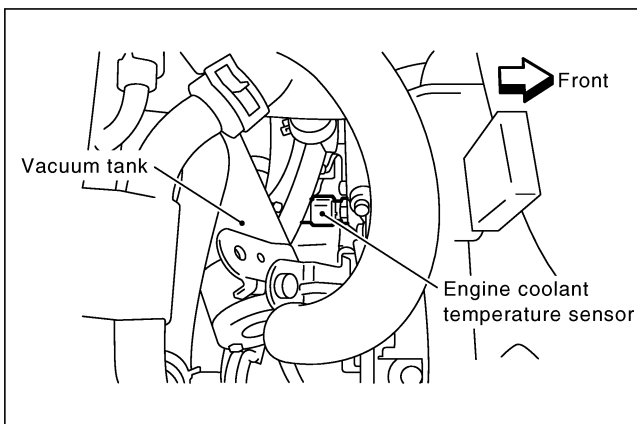
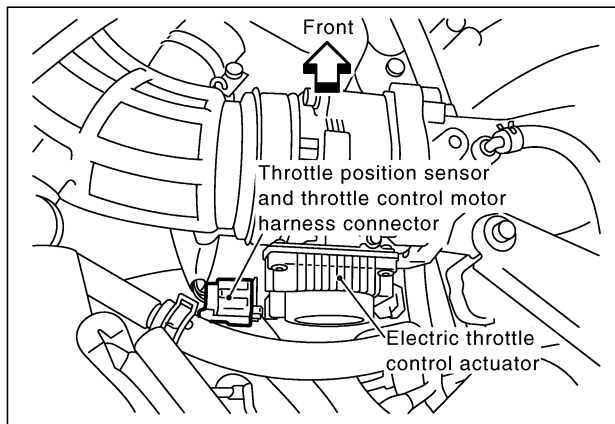
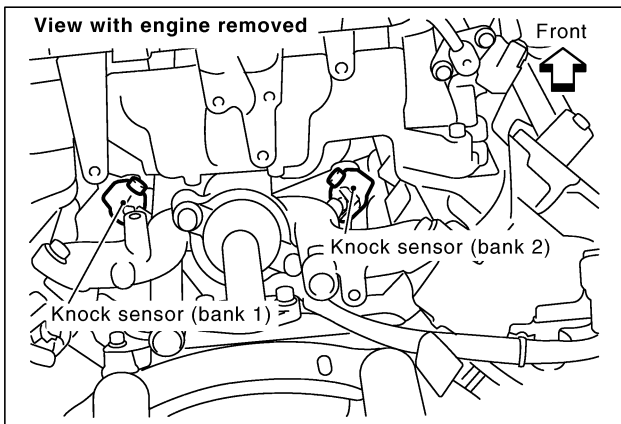

PBIB1545E

TROUBLE DIAGNOSIS

[VK45DE]

A
EC
C
D
E
F
G
H
I
J
K
L
M

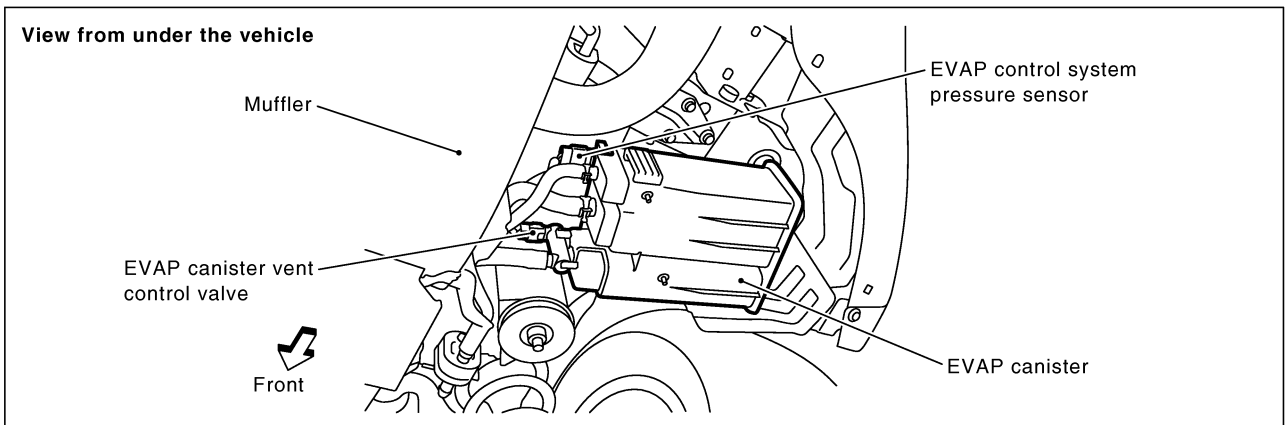
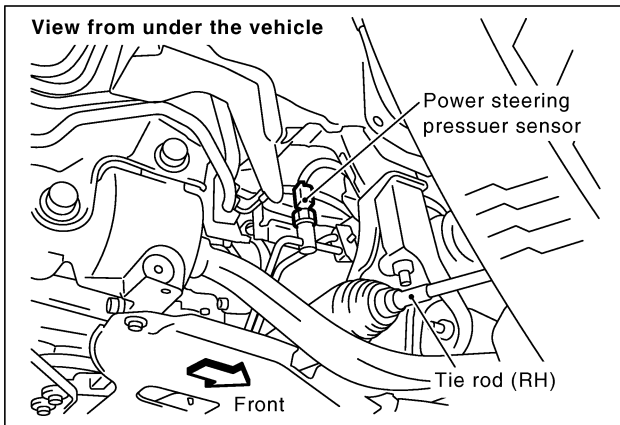
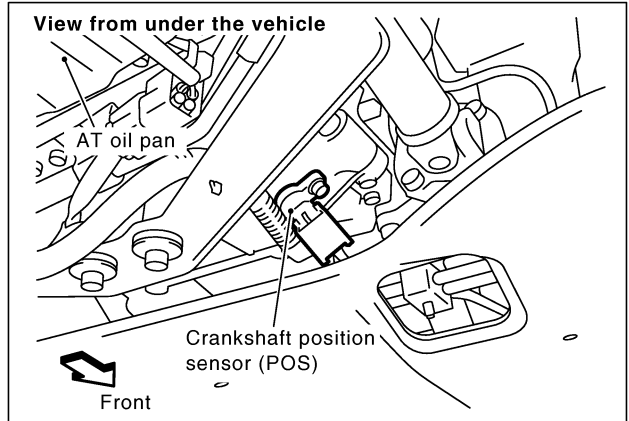
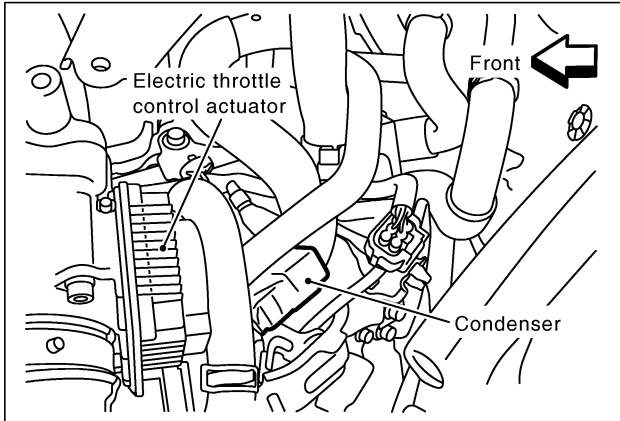
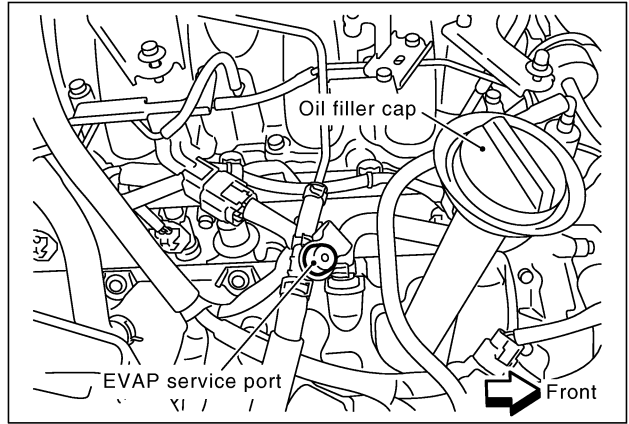
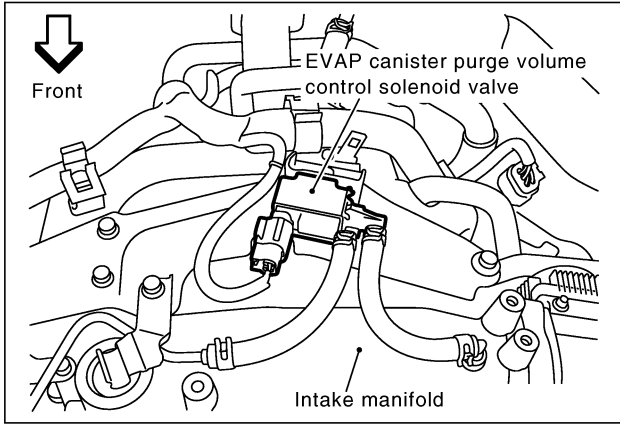

PBIB1546E

TROUBLE DIAGNOSIS

[VK45DE]

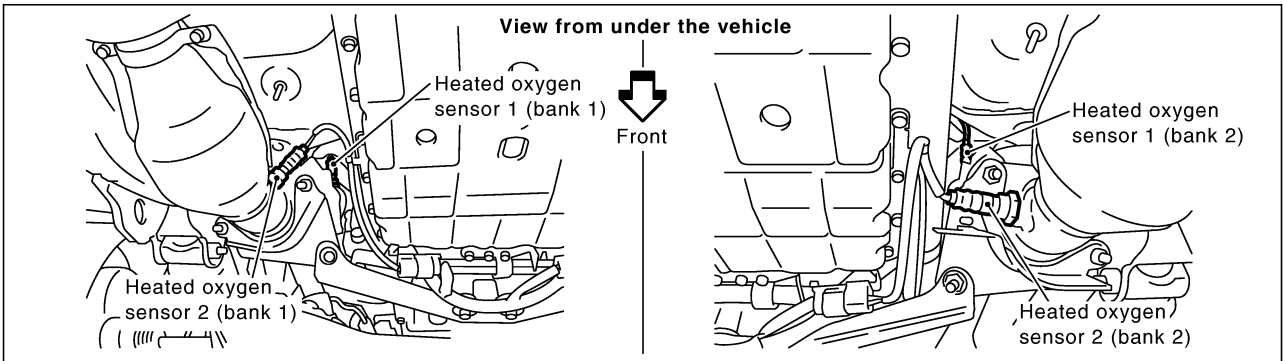
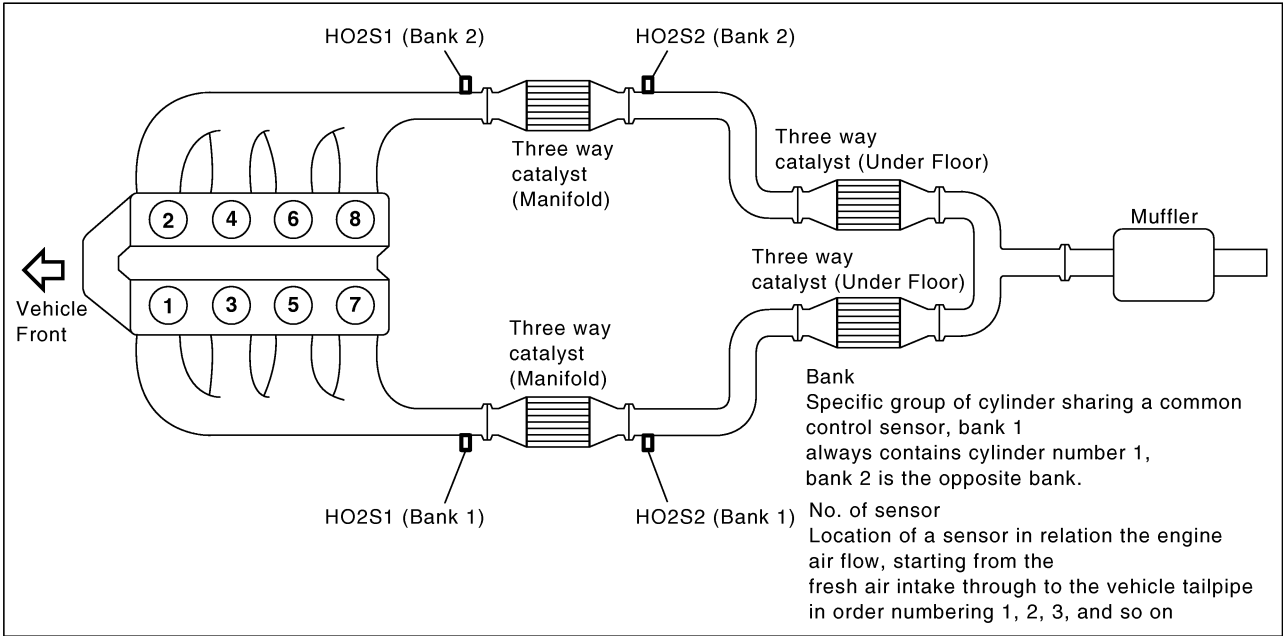

PBIB1543E

TROUBLE DIAGNOSIS

[VK45DE]

A
EC
C
D
E
F
G
H
I
J
K
L
M

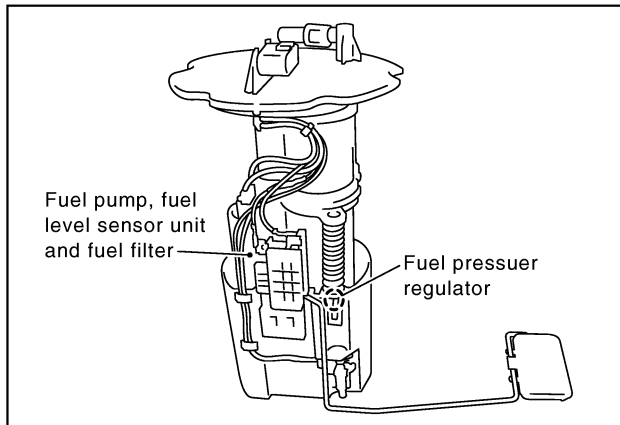
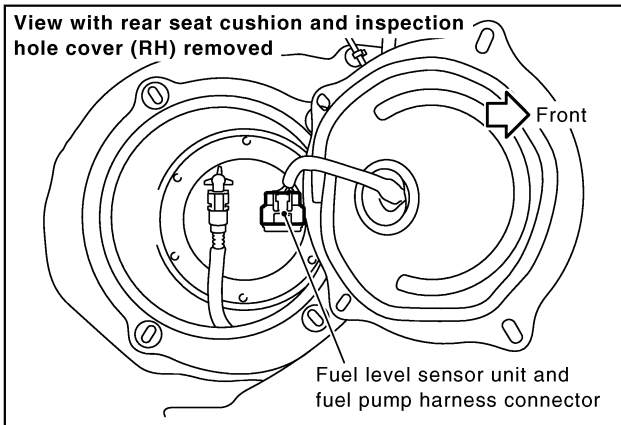
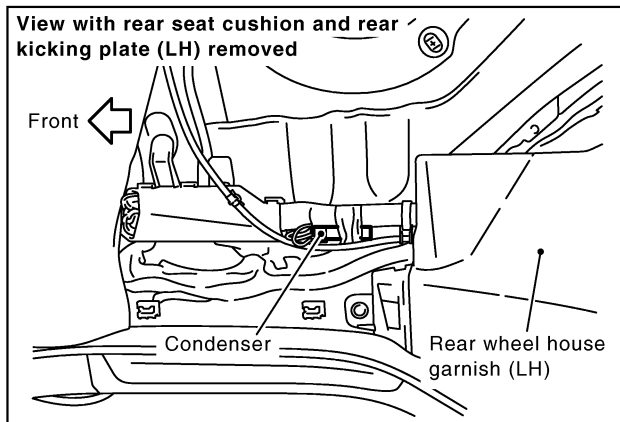
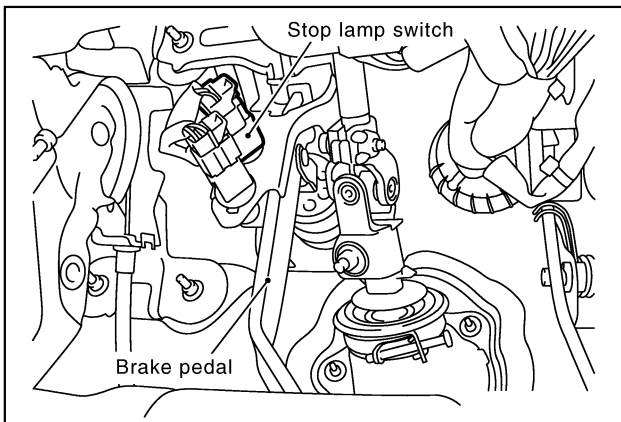
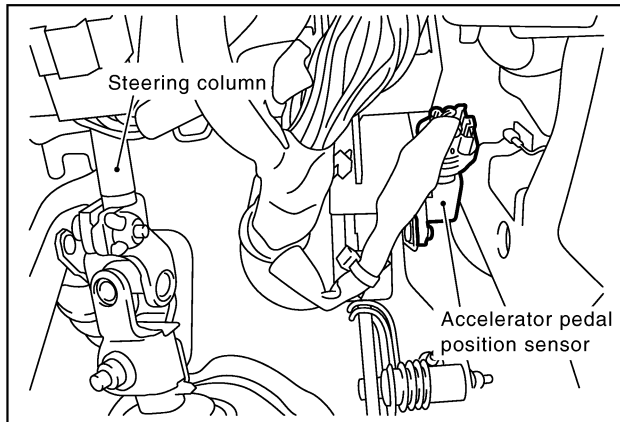
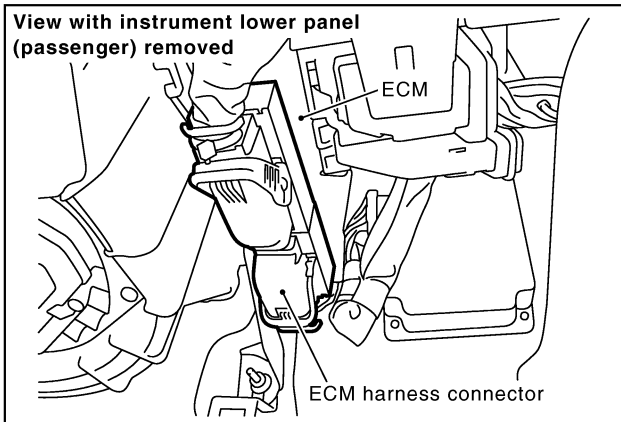

PBIB1547E

Circuit Diagram

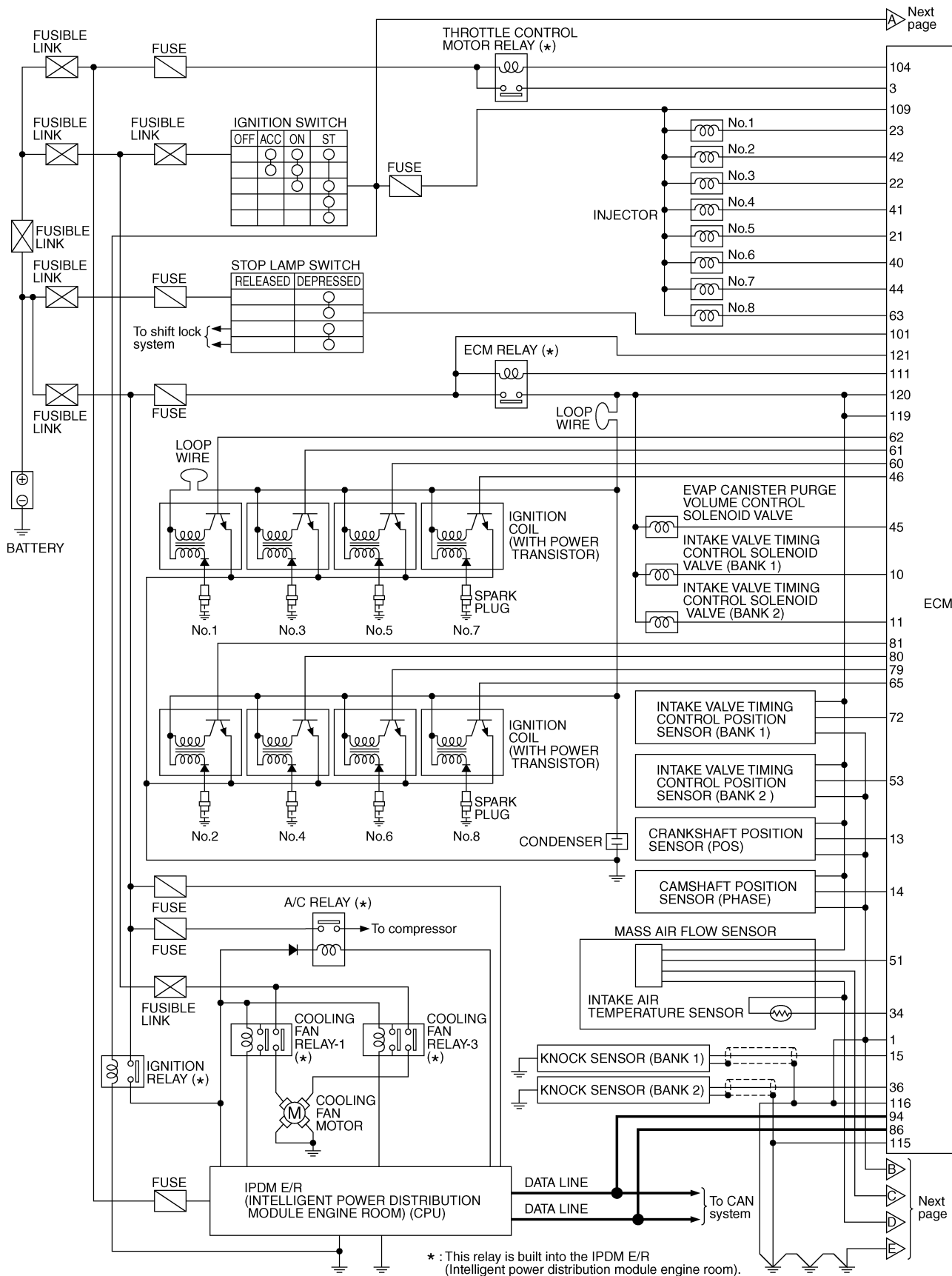

TROUBLE DIAGNOSIS

[VK45DE]

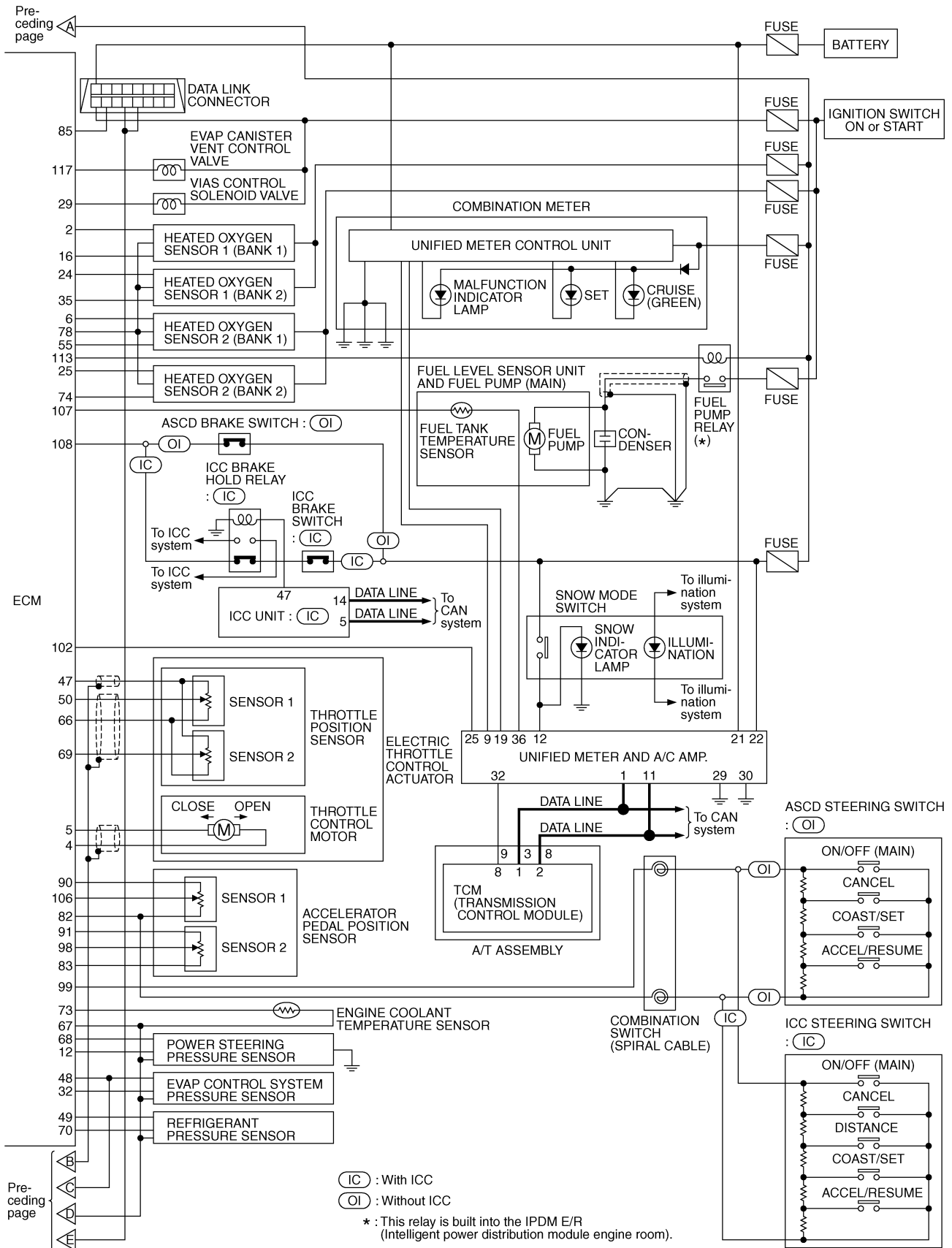

A

EC

C

D

E

F

G

H

I

J

K

L

M

TBWM0520E

ECM Harness Connector Terminal Layout

ABS00BZV

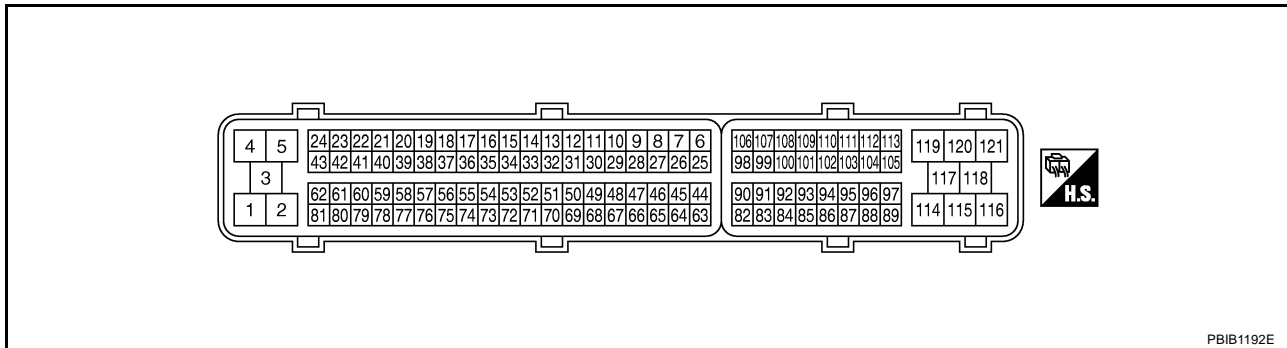

PBIB1192E

ECM Terminals and Reference Value PREPARATION

ABS00BZW

1. ECM is located behind the passenger side instrument lower panel. For this inspection, remove passenger side instrument lower panel.
2. Remove ECM harness connector.

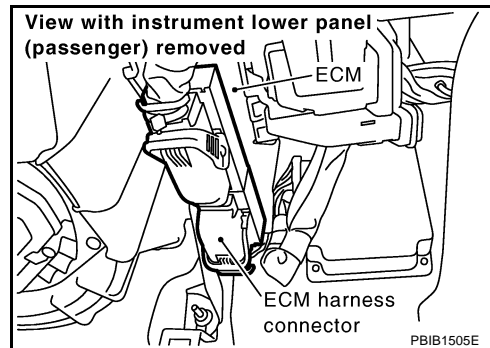

PBIB1505E

3. When disconnecting ECM harness connector, loosen it with levers as far as they will go as shown at right.
4. Connect a break-out box (SST) and Y-cable adapter (SST) between the ECM and ECM harness connector.
 - Use extreme care not to touch 2 pins at one time.
 - Data is for comparison and may not be exact.

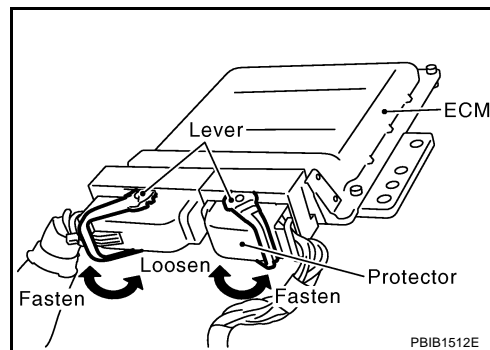

PBIB1512E

ECM INSPECTION TABLE

Specification data are reference values and are measured between each terminal and ground. Pulse signal is measured by CONSULT-II.



CAUTION:

Do not use ECM ground terminals when measuring input/output voltage. Doing so may result in damage to the ECM's transistor. Use a ground other than ECM terminals, such as the ground.

TER-MINAL NO.	WIRE COLOR	ITEM	CONDITION	DATA (DC Voltage)
1	B	ECM ground	[Engine is running] ● Idle speed	Body ground

TROUBLE DIAGNOSIS

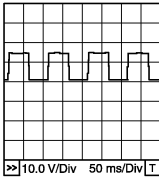
[VK45DE]

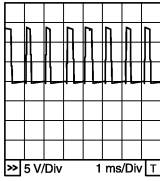
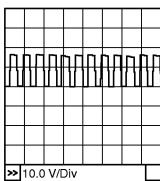
TER-MINAL NO.	WIRE COLOR	ITEM	CONDITION	DATA (DC Voltage)
2	L	Heated oxygen sensor 1 heater (bank 1)	[Engine is running] <ul style="list-style-type: none"> ● Warm-up condition ● Engine speed is below 3,000 rpm 	Approximately 7V★  <small>PBIB0519E</small>
			[Engine is running] <ul style="list-style-type: none"> ● Engine speed is above 3,000 rpm 	BATTERY VOLTAGE (11 - 14V)
3	P	Throttle control motor relay power supply	[Ignition switch: ON]	BATTERY VOLTAGE (11 - 14V)
4	L/W	Throttle control motor (Close)	[Ignition switch: ON] <ul style="list-style-type: none"> ● Engine stopped ● Shift lever position is D ● Accelerator pedal is released 	0 - 14V★  <small>PBIB1104E</small>
5	L/B	Throttle control motor (Open)	[Ignition switch: ON] <ul style="list-style-type: none"> ● Engine stopped ● Shift lever position is D ● Accelerator pedal is fully depressed 	0 - 14V★  <small>PBIB1105E</small>
6	R	Heated oxygen sensor 2 heater (bank 1)	[Engine is running] <ul style="list-style-type: none"> ● Engine speed is below 3,600 rpm after the following conditions are met <ul style="list-style-type: none"> - Engine: after warming up - Keeping the engine speed between 3,500 and 4,000 rpm for 1 minute and at idle for 1 minute under no load 	0 - 1.0V
			[Ignition switch: ON] <ul style="list-style-type: none"> ● Engine stopped [Engine is running] <ul style="list-style-type: none"> ● Engine speed is above 3,600 rpm 	BATTERY VOLTAGE (11 - 14V)
10	OR	Intake valve timing control solenoid valve (bank 1)	[Engine is running] <ul style="list-style-type: none"> ● Warm-up condition ● Idle speed 	BATTERY VOLTAGE (11 - 14V)
			[Engine is running] <ul style="list-style-type: none"> ● Warm-up condition ● Engine speed is 2,000rpm 	7 - 12V★  <small>PBIB1790E</small>

A
EC
C
D
E
F
G
H
I
J
K
L
M

TROUBLE DIAGNOSIS

[VK45DE]

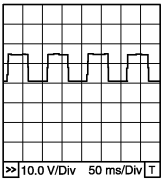
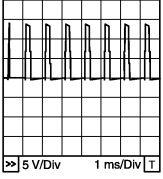
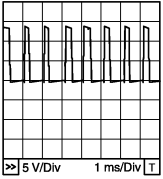
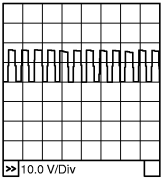
TER-MINAL NO.	WIRE COLOR	ITEM	CONDITION	DATA (DC Voltage)
2	L	Heated oxygen sensor 1 heater (bank 1)	<p>[Engine is running]</p> <ul style="list-style-type: none"> ● Warm-up condition ● Engine speed is below 3,000 rpm 	<p>A</p>  <p style="text-align: right; font-size: small;">PBIB0519E</p>
			<p>[Engine is running]</p> <ul style="list-style-type: none"> ● Engine speed is above 3,000 rpm 	<p>BATTERY VOLTAGE (11 - 14V)</p>
3	P	Throttle control motor relay power supply	<p>[Ignition switch: ON]</p>	<p>BATTERY VOLTAGE (11 - 14V)</p>
4	L/W	Throttle control motor (Close)	<p>[Ignition switch: ON]</p> <ul style="list-style-type: none"> ● Engine stopped ● Shift lever position is D ● Accelerator pedal is released 	<p>0</p>  <p style="text-align: right; font-size: small;">PBIB1104E</p>
5	L/B	Throttle control motor (Open)	<p>[Ignition switch: ON]</p> <ul style="list-style-type: none"> ● Engine stopped ● Shift lever position is D ● Accelerator pedal is fully depressed 	<p>0</p>  <p style="text-align: right; font-size: small;">PBIB1105E</p>
6	R	Heated oxygen sensor 2 heater (bank 1)	<p>[Engine is running]</p> <ul style="list-style-type: none"> ● Engine speed is below 3,600 rpm after the following conditions are met <ul style="list-style-type: none"> - Engine: after warming up - Keeping the engine speed between 3,500 and 4,000 rpm for 1 minute and at idle for 1 minute under no load 	<p>0 - 1.0V</p>
			<p>[Ignition switch: ON]</p> <ul style="list-style-type: none"> ● Engine stopped <p>[Engine is running]</p> <ul style="list-style-type: none"> ● Engine speed is above 3,600 rpm 	<p>BATTERY VOLTAGE (11 - 14V)</p>
10	OR	Intake valve timing control solenoid valve (bank 1)	<p>[Engine is running]</p> <ul style="list-style-type: none"> ● Warm-up condition ● Idle speed 	<p>BATTERY VOLTAGE (11 - 14V)</p>
			<p>[Engine is running]</p> <ul style="list-style-type: none"> ● Warm-up condition ● Engine speed is 2,000rpm 	<p>7</p>  <p style="text-align: right; font-size: small;">PBIB1790E</p>

TROUBLE DIAGNOSIS

[VK45DE]

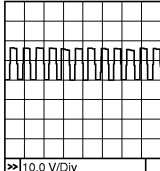
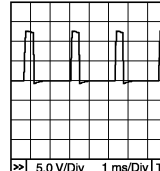
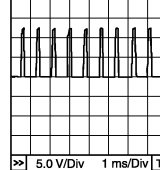
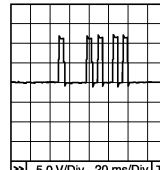
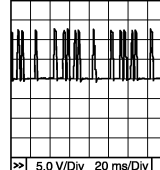
TER-MINAL NO.	WIRE COLOR	ITEM	CONDITION	DATA (DC Voltage)
11	BR	Intake valve timing control solenoid valve (bank 2)	[Engine is running] ● Warm-up condition ● Idle speed	BATTERY VOLTAGE (11 - 14V)
			[Engine is running] ● Warm-up condition ● Engine speed is 2,000rpm	7 - 12V★  PBIB1790E
12	R/G	Power steering pressure sensor	[Engine is running] ● Steering wheel is being turned	0.5 - 4.5V
			[Engine is running] ● Steering wheel is not being turned	0.4 - 0.8V
13	Y	Crankshaft position sensor (POS)	[Engine is running] ● Warm-up condition ● Idle speed NOTE: The pulse cycle changes depending on rpm at idle	1.0 - 2.0V★  PBIB1041E
			[Engine is running] ● Engine speed is 2,000 rpm	1.0 - 2.0V★  PBIB1042E
14	W	Camshaft position sensor (PHASE)	[Engine is running] ● Warm-up condition ● Idle speed NOTE: The pulse cycle changes depending on rpm at idle	1.0 - 4.0V★  PBIB1039E
			[Engine is running] ● Engine speed is 2,000 rpm	1.0 - 4.0V★  PBIB1040E
15	W	Knock sensor 1	[Engine is running] ● Idle speed	Approximately 2.5V
16	R/L	Heated oxygen sensor 1 (bank 1)	[Engine is running] ● Warm-up condition ● Engine speed is 2,000 rpm	0 - Approximately 1.0V (Periodically change)

A
EC
C
D
E
F
G
H
I
J
K
L
M

TROUBLE DIAGNOSIS

[VK45DE]

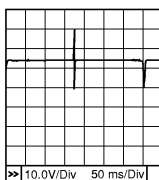
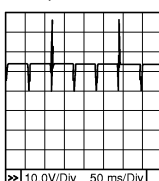
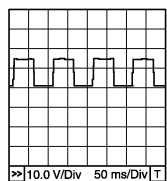
TER-MINAL NO.	WIRE COLOR	ITEM	CONDITION	DATA (DC Voltage)
21 22 23 40 41 42 44 63	W R P PU BR B OR G	Injector No. 5 Injector No. 3 Injector No. 1 Injector No. 6 Injector No. 4 Injector No. 2 Injector No. 7 Injector No. 8	<p>[Engine is running]</p> <ul style="list-style-type: none"> ● Warm-up condition ● Idle speed <p>NOTE: The pulse cycle changes depending on rpm at idle</p>	<p>BATTERY VOLTAGE (11 - 14V)★</p>  <p style="text-align: right; font-size: small;">PBIB0042E</p>
			<p>[Engine is running]</p> <ul style="list-style-type: none"> ● Warm-up condition ● Engine speed is 2,000 rpm 	<p>BATTERY VOLTAGE (11 - 14V)★</p>  <p style="text-align: right; font-size: small;">PBIB0043E</p>
24	BR	Heated oxygen sensor 1 heater (bank 2)	<p>[Engine is running]</p> <ul style="list-style-type: none"> ● Warm-up condition ● Engine speed is below 3,000 rpm 	<p>Approximately 7V★</p>  <p style="text-align: right; font-size: small;">PBIB0519E</p>
			<p>[Engine is running]</p> <ul style="list-style-type: none"> ● Engine speed is above 3,000 rpm 	<p>BATTERY VOLTAGE (11 - 14V)</p>
25	P	Heated oxygen sensor 2 heater (bank 2)	<p>[Engine is running]</p> <ul style="list-style-type: none"> ● Engine speed is below 3,600 rpm after the following conditions are met <ul style="list-style-type: none"> - Engine: after warming up - Keeping the engine speed between 3,500 and 4,000 rpm for 1 minute and at idle for 1 minute under no load 	<p>0 - 1.0V</p>
			<p>[Ignition switch: ON]</p> <ul style="list-style-type: none"> ● Engine stopped <p>[Engine is running]</p> <ul style="list-style-type: none"> ● Engine speed is above 3,600 rpm 	<p>BATTERY VOLTAGE (11 - 14V)</p>
29	GY	VIAS control solenoid valve	<p>[Engine is running]</p> <ul style="list-style-type: none"> ● Shift lever position is P or N 	<p>0 - 1.0V</p>
			<p>[Engine is running]</p> <ul style="list-style-type: none"> ● Shift lever position is D 	<p>BATTERY VOLTAGE (11 - 14V)</p>
			<p>[Engine is running]</p> <ul style="list-style-type: none"> ● Engine speed is above 5,000 rpm 	<p>0 - 1.0V</p>
32	OR	EVAP control system pressure sensor	<p>[Ignition switch: ON]</p>	<p>Approximately 1.8 - 4.8V</p>
34	Y	Intake air temperature sensor	<p>[Engine is running]</p>	<p>Approximately 0 - 4.8V Output voltage varies with intake air temperature.</p>

TROUBLE DIAGNOSIS

[VK45DE]

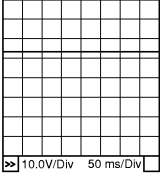
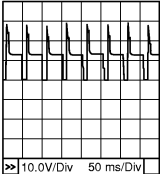
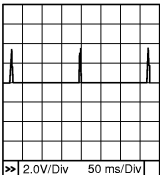
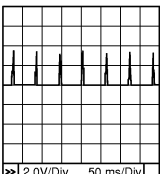
TER-MINAL NO.	WIRE COLOR	ITEM	CONDITION	DATA (DC Voltage)
35	BR	Heated oxygen sensor 1 (bank 2)	[Engine is running] <ul style="list-style-type: none"> ● Warm-up condition ● Engine speed is 2,000 rpm 	0 - Approximately 1.0V (Periodically change)
36	W	Knock sensor 2	[Engine is running] <ul style="list-style-type: none"> ● Idle speed 	Approximately 2.5V
45	W	EVAP canister purge volume control solenoid valve	[Engine is running] <ul style="list-style-type: none"> ● Idle speed 	BATTERY VOLTAGE (11 - 14V)★  <small>PBIB0050E</small>
			[Engine is running] <ul style="list-style-type: none"> ● Engine speed is about 2,000 rpm (More than 100 seconds after starting engine) 	11 - 14V★  <small>PBIB0051E</small>
46 60 61 62 65 79 80 81	L SB L Y Y LG GY G	Ignition signal No. 7 Ignition signal No. 5 Ignition signal No. 3 Ignition signal No. 1 Ignition signal No. 8 Ignition signal No. 6 Ignition signal No. 4 Ignition signal No. 2	[Engine is running] <ul style="list-style-type: none"> ● Warm-up condition ● Idle speed NOTE: The pulse cycle changes depending on rpm at idle	0 - 0.2V★  <small>PBIB0044E</small>
			[Engine is running] <ul style="list-style-type: none"> ● Warm-up condition ● Engine speed is 2,000 rpm 	0.1 - 0.4V★  <small>PBIB0045E</small>
47	L	Sensor power supply (Throttle position sensor)	[Ignition switch: ON]	Approximately 5V
48	L	Sensor power supply (Mass air flow sensor / EVAP control system pressure sensor)	[Ignition switch: ON]	Approximately 5V
49	PU	Sensor power supply (Refrigerant pressure sensor)	[Ignition switch: ON]	Approximately 5V

A
EC
C
D
E
F
G
H
I
J
K
L
M

TROUBLE DIAGNOSIS

[VK45DE]

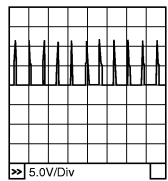
TER-MINAL NO.	WIRE COLOR	ITEM	CONDITION	DATA (DC Voltage)
50	W	Throttle position sensor 1	[Ignition switch: ON] <ul style="list-style-type: none"> ● Engine stopped ● Shift lever position is D ● Accelerator pedal is fully released 	More than 0.36V
			[Ignition switch: ON] <ul style="list-style-type: none"> ● Engine stopped ● Shift lever position is D ● Accelerator pedal is fully depressed 	Less than 4.75V
51	L/W	Mass air flow sensor	[Engine is running] <ul style="list-style-type: none"> ● Warm-up condition ● Idle speed 	1.2 - 1.8V
			[Engine is running] <ul style="list-style-type: none"> ● Warm-up condition ● Engine speed is 2,500 rpm 	1.7 - 2.4V
53	R/L	Intake valve timing control position sensor (bank 2)	[Engine is running] <ul style="list-style-type: none"> ● Warm-up condition ● Idle speed 	0 - 1.0V
			[Engine is running] <ul style="list-style-type: none"> ● Engine speed is 2,000 rpm 	0 - 1.0V★  <small>PBIB2046E</small>
55	W/R	Heated oxygen sensor 2 (bank 1)	[Engine is running] <ul style="list-style-type: none"> ● Warm-up condition ● Revving engine from idle to 3,000 rpm quickly after the following conditions are met <ul style="list-style-type: none"> - After keeping the engine speed between 3,500 and 4,000 rpm for 1 minute and at idle for 1 minute under no load 	0 - Approximately 1.0V
66	B	Sensor ground (Throttle position sensor)	[Engine is running] <ul style="list-style-type: none"> ● Warm-up condition ● Idle speed 	Approximately 0V
67	B/W	Sensor ground (Mass air flow sensor / IAT sensor / Power steering pressure sensor / EVAP control system pressure sensor / Refrigerant pressure sensor / ECT sensor)	[Engine is running] <ul style="list-style-type: none"> ● Warm-up condition ● Idle speed 	Approximately 0V
68	SB	Sensor power supply (Power steering pressure sensor)	[Ignition switch: ON]	Approximately 5V

TROUBLE DIAGNOSIS

[VK45DE]

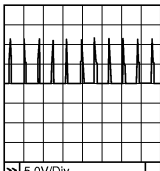
TER-MINAL NO.	WIRE COLOR	ITEM	CONDITION	DATA (DC Voltage)
69	R	Throttle position sensor 2	[Ignition switch: ON] <ul style="list-style-type: none"> ● Engine stopped ● Shift lever position is D ● Accelerator pedal is fully released 	Less than 4.75V
			[Ignition switch: ON] <ul style="list-style-type: none"> ● Engine stopped ● Shift lever position is D ● Accelerator pedal is fully depressed 	More than 0.36V
70	L/R	Refrigerant pressure sensor	[Engine is running] <ul style="list-style-type: none"> ● Warm-up condition ● Both A/C switch and blower switch are ON (Compressor operates) 	1.0 - 4.0V
72	BR	Intake valve timing control position sensor (bank 1)	[Engine is running] <ul style="list-style-type: none"> ● Warm-up condition ● Idle speed 	0 - 1.0V
			[Engine is running] <ul style="list-style-type: none"> ● Engine speed is 2,000rpm 	0 - 1.0V★  <small>PBIB2046E</small>
73	OR	Engine coolant temperature sensor	[Engine is running]	Approximately 0 - 4.8V Output voltage varies with engine coolant temperature.
74	LG/B	Heated oxygen sensor 2 (bank 2)	[Engine is running] <ul style="list-style-type: none"> ● Warm-up condition ● Revving engine from idle to 3,000 rpm quickly after the following conditions are met - After keeping the engine speed between 3,500 and 4,000 rpm for 1 minute and at idle for 1 minute under no load 	0 - Approximately 1.0V
78	B/R	Sensor ground (Heated oxygen sensor)	[Engine is running] <ul style="list-style-type: none"> ● Warm-up condition ● Idle speed 	Approximately 0V
82	B/W	Sensor ground (APP sensor 1 / Steering switch)	[Engine is running] <ul style="list-style-type: none"> ● Warm-up condition ● Idle speed 	Approximately 0V
83	G/OR	Sensor ground (APP sensor 2)	[Engine is running] <ul style="list-style-type: none"> ● Warm-up condition ● Idle speed 	Approximately 0V
85	PU	Data link connector	[Ignition switch: ON] <ul style="list-style-type: none"> ● CONSULT-II or GST is disconnected 	Approximately 5V - Battery voltage (11 - 14V)
86	R	CAN communication line	[Ignition switch: ON]	Approximately 1.1 - 2.3V Output voltage varies with the communication status.
90	L/B	Sensor power supply (APP sensor 1)	[Ignition switch: ON]	Approximately 5V

A
EC
C
D
E
F
G
H
I
J
K
L
M

TROUBLE DIAGNOSIS

[VK45DE]

TER-MINAL NO.	WIRE COLOR	ITEM	CONDITION	DATA (DC Voltage)
91	G	Sensor power supply (APP sensor 2)	[Ignition switch: ON]	Approximately 5V
94	L	CAN communication line	[Ignition switch: ON]	Approximately 2.6 - 3.2V Output voltage varies with the communication status.
98	B/P	Accelerator pedal position sensor 2	[Ignition switch: ON] ● Engine stopped ● Accelerator pedal is fully released	0.15 - 0.60V
			[Ignition switch: ON] ● Engine stopped ● Accelerator pedal is fully depressed	1.95 - 2.40V
99	G/Y	ICC steering switch (models with ICC system)	[Ignition switch: ON] ● ICC steering switch: OFF	Approximately 4.3V
			[Ignition switch: ON] ● ON/OFF (MAIN) switch: Pressed	Approximately 0V
			[Ignition switch: ON] ● CANCEL switch: Pressed	Approximately 1.3V
			[Ignition switch: ON] ● DISTANCE switch: Pressed	Approximately 2.2V
			[Ignition switch: ON] ● COAST/SET switch: Pressed	Approximately 3V
			[Ignition switch: ON] ● ACCEL/RESUME switch: Pressed	Approximately 3.7V
99	G/Y	ASCD steering switch (models with ASCD system)	[Ignition switch: ON] ● ASCD steering switch: OFF	Approximately 4V
			[Ignition switch: ON] ● ON/OFF (MAIN) switch: Pressed	Approximately 0V
			[Ignition switch: ON] ● CANCEL switch: Pressed	Approximately 1V
			[Ignition switch: ON] ● COAST/SET switch: Pressed	Approximately 2V
			[Ignition switch: ON] ● ACCEL/RESUME switch: Pressed	Approximately 3V
101	P/L	Stop lamp switch	[Ignition switch: OFF] ● Brake pedal is fully released	Approximately 0V
			[Ignition switch: OFF] ● Brake pedal is depressed	BATTERY VOLTAGE (11 - 14V)
102	LG/B	PNP switch	[Ignition switch: ON] ● Shift lever position is P or N	Approximately 0V
			[Ignition switch: ON] ● Except above position	BATTERY VOLTAGE (11 - 14V)
104	L/OR	Throttle control motor relay	[Ignition switch: OFF]	BATTERY VOLTAGE (11 - 14V)
			[Ignition switch: ON]	0 - 1.0V

TROUBLE DIAGNOSIS

[VK45DE]

TER-MINAL NO.	WIRE COLOR	ITEM	CONDITION	DATA (DC Voltage)	
106	R/B	Accelerator pedal position sensor 1	[Ignition switch: ON] ● Engine stopped ● Accelerator pedal is fully released	0.5 - 1.0V	A
			[Ignition switch: ON] ● Engine stopped ● Accelerator pedal is fully depressed	3.9 - 4.7V	EC
107	PU/W	Fuel tank temperature sensor	[Engine is running]	Approximately 0 - 4.8V Output voltage varies with fuel tank temperature.	C
108	SB	ICC brake switch (models with ICC system) ASCD brake switch (models with ASCD system)	[Ignition switch: ON] ● Brake pedal is depressed	Approximately 0V	D
			[Ignition switch: ON] ● Brake pedal is fully released	BATTERY VOLTAGE (11 - 14V)	E
109	W/L	Ignition switch	[Ignition switch: OFF]	0V	F
			[Ignition switch: ON]	BATTERY VOLTAGE (11 - 14V)	G
111	W/B	ECM relay (Self shut-off)	[Engine is running] [Ignition switch: OFF] ● For a few seconds after turning ignition switch OFF	0 - 1.5V	H
			[Ignition switch: OFF] ● More than a few seconds after turning ignition switch OFF	BATTERY VOLTAGE (11 - 14V)	I
113	GY/R	Fuel pump relay	[Ignition switch: ON] ● For 1 second after turning ignition switch ON [Engine is running]	0 - 1.5V	J
			[Ignition switch: ON] ● More than 1 second after turning ignition switch ON	BATTERY VOLTAGE (11 - 14V)	K
115 116	B/R B/W	ECM ground	[Engine is running] ● Idle speed	Body ground	L
117	R/Y	EVAP canister vent control valve	[Ignition switch: ON]	BATTERY VOLTAGE (11 - 14V)	M
119 120	R R	Power supply for ECM	[Ignition switch: ON]	BATTERY VOLTAGE (11 - 14V)	
121	R/W	Power supply for ECM (Back-up)	[Ignition switch: OFF]	BATTERY VOLTAGE (11 - 14V)	

★: Average voltage for pulse signal (Actual pulse signal can be confirmed by oscilloscope.)

CONSULT-II Function FUNCTION

ABS00BZX

Diagnostic test mode	Function
Work support	This mode enables a technician to adjust some devices faster and more accurately by following the indications on the CONSULT-II unit.
Self-diagnostic results	Self-diagnostic results such as 1st trip DTC, DTCs and 1st trip freeze frame data or freeze frame data can be read and erased quickly.*
Data monitor	Input/Output data in the ECM can be read.
Data monitor (SPEC)	Input/Output of the specification for Basic fuel schedule, AFM, A/F feedback control value and the other data monitor items can be read.

TROUBLE DIAGNOSIS

[VK45DE]

Diagnostic test mode	Function
CAN diagnostic support monitor	The results of transmit/receive diagnosis of CAN communication can be read.
Active test	Diagnostic Test Mode in which CONSULT-II drives some actuators apart from the ECMs and also shifts some parameters in a specified range.
DTC & SRT confirmation	The status of system monitoring tests and the self-diagnosis status/result can be confirmed.
Function test	This mode is used to inform customers when their vehicle condition requires periodic maintenance.
ECM part number	ECM part number can be read.

*: The following emission-related diagnostic information is cleared when the ECM memory is erased.

- Diagnostic trouble codes
- 1st trip diagnostic trouble codes
- Freeze frame data
- 1st trip freeze frame data
- System readiness test (SRT) codes
- Test values
- Others

TROUBLE DIAGNOSIS

[VK45DE]

ENGINE CONTROL COMPONENT PARTS/CONTROL SYSTEMS APPLICATION

Item		DIAGNOSTIC TEST MODE							
		WORK SUP-PORT	SELF-DIAGNOS-TIC RESULTS		DATA MONI-TOR	DATA MONI-TOR (SPEC)	ACTIVE TEST	DTC & SRT CONFIRMATION	
			DTC*1	FREEZE FRAME DATA*2				SRT STATUS	DTC WORK SUP-PORT
ENGINE CONTROL COMPONENT PARTS INPUT	Crankshaft position sensor (POS)		×	×	×	×			
	Camshaft position sensor (PHASE)		×	×	×	×			
	Mass air flow sensor		×		×	×			
	Engine coolant temperature sensor		×	×	×	×	×		
	Heated oxygen sensor 1		×		×	×		×	×
	Heated oxygen sensor 2		×		×	×		×	×
	Wheel sensor		×	×	×	×			
	Accelerator pedal position sensor		×		×	×			
	Throttle position sensor		×		×	×			
	Fuel tank temperature sensor		×		×	×	×		
	EVAP control system pressure sensor		×		×	×			
	Intake air temperature sensor		×	×	×	×			
	Knock sensor		×						
	Refrigerant pressure sensor				×	×			
	Closed throttle position switch (accelerator pedal position sensor signal)				×	×			
	Air conditioner switch				×	×			
	Park/neutral position (PNP) switch		×		×	×			
	Stop lamp switch		×		×	×			
	Power steering pressure sensor		×		×	×			
	Battery voltage				×	×			
	Load signal				×	×			
	Snow mode switch				×	×			
	Intake valve timing control position sensor		×		×	×			
	Fuel level sensor		×		×	×			
	ICC steering switch		×		×	×			
	ASCD steering switch		×		×	×			
ICC brake switch		×		×	×				
ASCD brake switch		×		×	×				

TROUBLE DIAGNOSIS

[VK45DE]

Item		DIAGNOSTIC TEST MODE							
		WORK SUP-PORT	SELF-DIAGNOS-TIC RESULTS		DATA MONI-TOR	DATA MONI-TOR (SPEC)	ACTIVE TEST	DTC & SRT CONFIRMATION	
			DTC*1	FREEZE FRAME DATA*2				SRT STATUS	DTC WORK SUP-PORT
ENGINE CONTROL COMPONENT PARTS OUTPUT	Fuel injector				×	×	×		
	Power transistor (Ignition timing)				×	×	×		
	Throttle control motor relay		×		×	×			
	Throttle control motor		×						
	EVAP canister purge volume control solenoid valve		×		×	×	×		×
	Air conditioner relay				×	×			
	Fuel pump relay	×			×	×	×		
	Cooling fan relay		×		×	×	×		
	Heated oxygen sensor 1 heater		×		×	×		×	
	Heated oxygen sensor 2 heater		×		×	×		×	
	EVAP canister vent control valve	×	×		×	×	×		
	Intake valve timing control solenoid valve		×		×	×	×		
	VIAS control solenoid valve				×	×	×		
	Calculated load value			×	×	×			

X: Applicable

*1: This item includes 1st trip DTCs.

*2: This mode includes 1st trip freeze frame data or freeze frame data. The items appear on CONSULT-II screen in freeze frame data mode only if a 1st trip DTC or DTC is detected. For details, refer to [EC-708](#).

INSPECTION PROCEDURE

CAUTION:

If CONSULT-II is used with no connection of CONSULT-II CONVERTER, malfunctions might be detected in self-diagnosis depending on control unit which carry out CAN communication.

1. Turn ignition switch OFF.
2. Connect CONSULT-II and CONSULT-II CONVERTER to data link connector, which is located under LH dash panel near the hood opener handle.
3. Turn ignition switch ON.

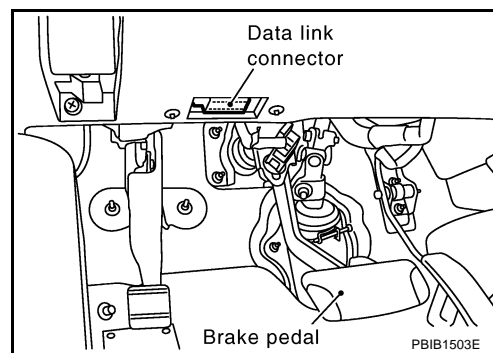

TROUBLE DIAGNOSIS

[VK45DE]

4. Touch "START (NISSAN BASED VHCL)".

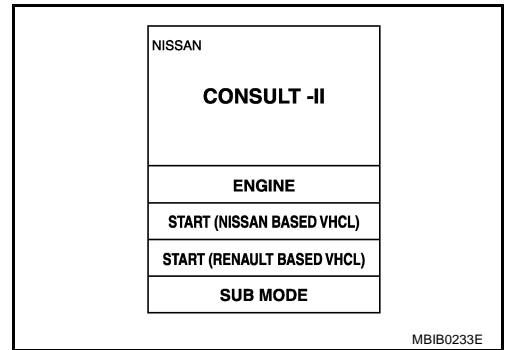

5. Touch "ENGINE".
If "ENGINE" is not indicated, go to [GI-40, "CONSULT-II Data Link Connector \(DLC\) Circuit"](#).

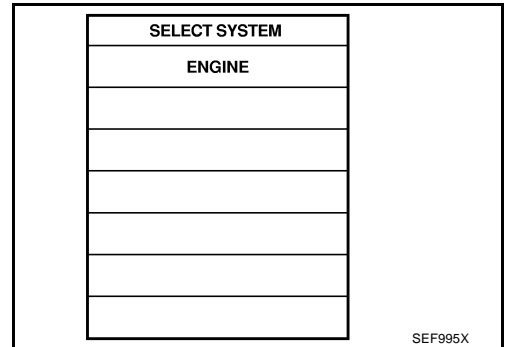

6. Perform each diagnostic test mode according to each service procedure.
For further information, see the CONSULT-II Operation Manual.

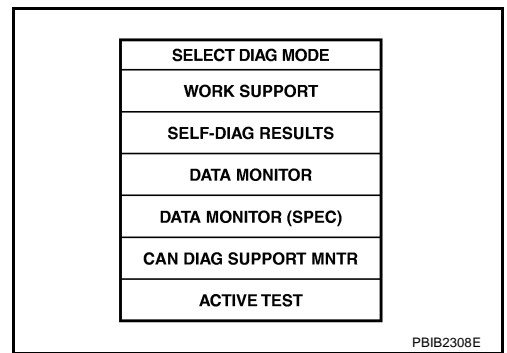

WORK SUPPORT MODE

Work Item

WORK ITEM	CONDITION	USAGE
FUEL PRESSURE RELEASE	<ul style="list-style-type: none"> FUEL PUMP WILL STOP BY TOUCHING "START" DURING IDLING. CRANK A FEW TIMES AFTER ENGINE STALLS. 	When releasing fuel pressure from fuel line
IDLE AIR VOL LEARN	<ul style="list-style-type: none"> THE IDLE AIR VOLUME THAT KEEPS THE ENGINE WITHIN THE SPECIFIED RANGE IS MEMORIZED IN ECM. 	When learning the idle air volume
SELF-LEARNING CONT	<ul style="list-style-type: none"> THE COEFFICIENT OF SELF-LEARNING CONTROL MIXTURE RATIO RETURNS TO THE ORIGINAL COEFFICIENT. 	When clearing the coefficient of self-learning control value

TROUBLE DIAGNOSIS

[VK45DE]

WORK ITEM	CONDITION	USAGE
EVAP SYSTEM CLOSE	<p>CLOSE THE EVAP CANISTER VENT CONTROL VALVE IN ORDER TO MAKE EVAP SYSTEM CLOSE UNDER THE FOLLOWING CONDITIONS.</p> <ul style="list-style-type: none"> ● IGN SW ON ● ENGINE NOT RUNNING ● AMBIENT TEMPERATURE IS ABOVE 0°C (32°F). ● NO VACUUM AND NO HIGH PRESSURE IN EVAP SYSTEM ● FUEL TANK TEMP. IS MORE THAN 0°C (32°F). ● WITHIN 10 MINUTES AFTER STARTING "EVAP SYSTEM CLOSE" ● WHEN TRYING TO EXECUTE "EVAP SYSTEM CLOSE" UNDER THE CONDITION EXCEPT ABOVE, CONSULT-II WILL DISCONTINUE IT AND DISPLAY APPROPRIATE INSTRUCTION. <p>NOTE: WHEN STARTING ENGINE, CONSULT-II MAY DISPLAY "BATTERY VOLTAGE IS LOW. CHARGE BATTERY", EVEN IN USING CHARGED BATTERY.</p>	When detecting EVAP vapor leak point of EVAP system
TARGET IDLE RPM ADJ*	● IDLE CONDITION	When setting target idle speed
TARGET IGN TIM ADJ*	● IDLE CONDITION	When adjusting target ignition timing

*: This function is not necessary in the usual service procedure.

SELF-DIAG RESULTS MODE

Self Diagnostic Item

Regarding items of DTC and 1st trip DTC, refer to [EC-662, "INDEX FOR DTC" .](#))

Freeze Frame Data and 1st Trip Freeze Frame Data

Freeze frame data item*	Description
DIAG TROUBLE CODE [PXXXX]	● The engine control component part/control system has a trouble code, it is displayed as PXXXX. (Refer to EC-662, "INDEX FOR DTC" .)
FUEL SYS-B1	● "Fuel injection system status" at the moment a malfunction is detected is displayed.
FUEL SYS-B2	<ul style="list-style-type: none"> ● One mode in the following is displayed. Mode2: Open loop due to detected system malfunction Mode3: Open loop due to driving conditions (power enrichment, deceleration enrichment) Mode4: Closed loop - using oxygen sensor(s) as feedback for fuel control Mode5: Open loop - has not yet satisfied condition to go to closed loop
CAL/LD VALUE [%]	● The calculated load value at the moment a malfunction is detected is displayed.
COOLANT TEMP [°C] or [°F]	● The engine coolant temperature at the moment a malfunction is detected is displayed.
L-FUEL TRM-B1 [%]	● "Long-term fuel trim" at the moment a malfunction is detected is displayed.
L-FUEL TRM-B2 [%]	● The long-term fuel trim indicates much more gradual feedback compensation to the base fuel schedule than short-term fuel trim.
S-FUEL TRM-B1 [%]	● "Short-term fuel trim" at the moment a malfunction is detected is displayed.
S-FUEL TRM-B2 [%]	● The short-term fuel trim indicates dynamic or instantaneous feedback compensation to the base fuel schedule.
ENGINE SPEED [rpm]	● The engine speed at the moment a malfunction is detected is displayed.
VEHICL SPEED [km/h] or [mph]	● The vehicle speed at the moment a malfunction is detected is displayed.

TROUBLE DIAGNOSIS

[VK45DE]

Freeze frame data item*	Description
B/FUEL SCHDL [msec]	<ul style="list-style-type: none"> The base fuel schedule at the moment a malfunction is detected is displayed.
INT/A TEMP SE [°C] or [°F]	<ul style="list-style-type: none"> The intake air temperature at the moment a malfunction is detected is displayed.

*: The items are the same as those of 1st trip freeze frame data.

DATA MONITOR MODE

Monitored Item

×: Applicable

Monitored item [Unit]	ECM INPUT SIGNALS	MAIN SIGNALS	Description	Remarks
ENG SPEED [rpm]	×	×	<ul style="list-style-type: none"> Indicates the engine speed computed from the signal of the crankshaft position sensor (POS) and camshaft position sensor (PHASE). 	<ul style="list-style-type: none"> Accuracy becomes poor if engine speed drops below the idle rpm. If the signal is interrupted while the engine is running, an abnormal value may be indicated.
MAS A/F SE-B1 [V]	×	×	<ul style="list-style-type: none"> The signal voltage of the mass air flow sensor is displayed. 	<ul style="list-style-type: none"> When the engine is stopped, a certain value is indicated.
B/FUEL SCHDL [msec]		×	<ul style="list-style-type: none"> "Base fuel schedule" indicates the fuel injection pulse width programmed into ECM, prior to any learned on board correction. 	
A/F ALPHA-B1 [%]		×	<ul style="list-style-type: none"> The mean value of the air-fuel ratio feedback correction factor per cycle is indicated. 	<ul style="list-style-type: none"> When the engine is stopped, a certain value is indicated. This data also includes the data for the air-fuel ratio learning control.
A/F ALPHA-B2 [%]		×		
COOLAN TEMP/S [°C] or [°F]	×	×	<ul style="list-style-type: none"> The engine coolant temperature (determined by the signal voltage of the engine coolant temperature sensor) is displayed. 	<ul style="list-style-type: none"> When the engine coolant temperature sensor is open or short-circuited, ECM enters fail-safe mode. The engine coolant temperature determined by the ECM is displayed.
HO2S1 (B1) [V]	×	×	<ul style="list-style-type: none"> The signal voltage of the heated oxygen sensor 1 is displayed. 	
HO2S1 (B2) [V]	×			
HO2S2 (B1) [V]	×		<ul style="list-style-type: none"> The signal voltage of the heated oxygen sensor 2 is displayed. 	
HO2S2 (B2) [V]	×			
HO2S1 MNTR (B1) [RICH/LEAN]	×	×	<ul style="list-style-type: none"> Display of heated oxygen sensor 1 signal during air-fuel ratio feedback control: RICH: means the mixture became "rich", and control is being affected toward a leaner mixture. LEAN: means the mixture became "lean", and control is being affected toward a rich mixture. 	<ul style="list-style-type: none"> After turning ON the ignition switch, "RICH" is displayed until air-fuel mixture ratio feedback control begins. When the air-fuel ratio feedback is clamped, the value just before the clamping is displayed continuously.
HO2S1 MNTR (B2) [RICH/LEAN]	×			
HO2S2 MNTR (B1) [RICH/LEAN]	×		<ul style="list-style-type: none"> Display of heated oxygen sensor 2 signal: RICH: means the amount of oxygen after three way catalyst is relatively small. LEAN: means the amount of oxygen after three way catalyst is relatively large. 	<ul style="list-style-type: none"> When the engine is stopped, a certain value is indicated.
HO2S2 MNTR (B2) [RICH/LEAN]	×			
VHCL SPEED SE [km/h] or [mph]	×	×	<ul style="list-style-type: none"> The vehicle speed computed from the vehicle speed signal sent from combination meter is displayed. 	

TROUBLE DIAGNOSIS

[VK45DE]

Monitored item [Unit]	ECM INPUT SIGNALS	MAIN SIGNALS	Description	Remarks
BATTERY VOLT [V]	×	×	<ul style="list-style-type: none"> The power supply voltage of ECM is displayed. 	
ACCEL SEN 1 [V]	×	×	<ul style="list-style-type: none"> The accelerator pedal position sensor signal voltage is displayed. 	<ul style="list-style-type: none"> ACCEL SEN 2 signal is converted by ECM internally. Thus, they differs from ECM terminal voltage signal.
ACCEL SEN 2 [V]	×			
THRTL SEN 1 [V]	×	×	<ul style="list-style-type: none"> The throttle position sensor signal voltage is displayed. 	<ul style="list-style-type: none"> THRTL SEN 2 signal is converted by ECM internally. Thus, they differs from ECM terminal voltage signal.
THRTL SEN 2 [V]	×			
FUEL T/TEMP SE [°C] or [°F]	×		<ul style="list-style-type: none"> The fuel temperature (determined by the signal voltage of the fuel tank temperature sensor) is displayed. 	
INT/A TEMP SE [°C] or [°F]	×	×	<ul style="list-style-type: none"> The intake air temperature (determined by the signal voltage of the intake air temperature sensor) is indicated. 	
EVAP SYS PRES [V]	×		<ul style="list-style-type: none"> The signal voltage of EVAP control system pressure sensor is displayed. 	
FUEL LEVEL SE [V]	×		<ul style="list-style-type: none"> The signal voltage of the fuel level sensor is displayed. 	
START SIGNAL [ON/OFF]	×	×	<ul style="list-style-type: none"> Indicates start signal status [ON/OFF] computed by the ECM according to the signals of engine speed and battery voltage. 	<ul style="list-style-type: none"> After starting the engine, [OFF] is displayed regardless of the starter signal.
CLSD THL POS [ON/OFF]	×	×	<ul style="list-style-type: none"> Indicates idle position [ON/OFF] computed by ECM according to the accelerator pedal position sensor signal. 	
AIR COND SIG [ON/OFF]	×	×	<ul style="list-style-type: none"> Indicates [ON/OFF] condition of the air conditioner switch as determined by the air conditioner signal. 	
P/N POSI SW [ON/OFF]	×	×	<ul style="list-style-type: none"> Indicates [ON/OFF] condition from the park/neutral position (PNP) switch signal. 	
PW/ST SIGNAL [ON/OFF]	×	×	<ul style="list-style-type: none"> [ON/OFF] condition of the power steering system (determined by the signal voltage of the power steering pressure sensor signal) is indicated. 	
LOAD SIGNAL [ON/OFF]	×	×	<ul style="list-style-type: none"> Indicates [ON/OFF] condition from the electrical load signal. ON: Rear window defogger switch is ON and/or lighting switch is in 2nd position. OFF: Both rear window defogger switch and lighting switch are OFF. 	
SNOW MODE SW [ON/OFF]			<ul style="list-style-type: none"> Indicates [ON/OFF] condition from the snow mode switch signal. 	
IGNITION SW [ON/OFF]	×		<ul style="list-style-type: none"> Indicates [ON/OFF] condition from ignition switch signal. 	
HEATER FAN SW [ON/OFF]	×		<ul style="list-style-type: none"> Indicates [ON/OFF] condition from the heater fan switch signal. 	
BRAKE SW [ON/OFF]			<ul style="list-style-type: none"> Indicates [ON/OFF] condition from the stop lamp switch signal. 	
INJ PULSE-B1 [msec]		×	<ul style="list-style-type: none"> Indicates the actual fuel injection pulse width compensated by ECM according to the input signals. 	<ul style="list-style-type: none"> When the engine is stopped, a certain computed value is indicated.
INJ PULSE-B2 [msec]				

TROUBLE DIAGNOSIS

[VK45DE]

Monitored item [Unit]	ECM INPUT SIGNALS	MAIN SIGNALS	Description	Remarks	
IGN TIMING [BTDC]		×	<ul style="list-style-type: none"> Indicates the ignition timing computed by ECM according to the input signals. 	<ul style="list-style-type: none"> When the engine is stopped, a certain value is indicated. 	A EC
CAL/LD VALUE [%]			<ul style="list-style-type: none"> "Calculated load value" indicates the value of the current air flow divided by peak air flow. 		C
MASS AIRFLOW [g·m/s]			<ul style="list-style-type: none"> Indicates the mass air flow computed by ECM according to the signal voltage of the mass air flow sensor. 		D
PURG VOL C/V [%]			<ul style="list-style-type: none"> Indicates the EVAP canister purge volume control solenoid valve control value computed by the ECM according to the input signals. The opening becomes larger as the value increases. 		E
INT/V TIM (B1) [°CA]			<ul style="list-style-type: none"> Indicates [°CA] of intake camshaft advanced angle. 		F
INT/V TIM (B2) [°CA]				G	
INT/V SOL (B1) [%]			<ul style="list-style-type: none"> The control value of the intake valve timing control solenoid valve (determined by ECM according to the input signals) is indicated. The advance angle becomes larger as the value increases. 		H
INT/V SOL (B2) [%]				I	
VIAS S/V [ON/OFF]			<ul style="list-style-type: none"> The control condition of the VIAS control solenoid valve (determined by ECM according to the input signals) is indicated. OFF: VIAS control solenoid valve is not operating. ON: VIAS control solenoid valve is operating. 		J
AIR COND RLY [ON/OFF]		×	<ul style="list-style-type: none"> The air conditioner relay control condition (determined by ECM according to the input signals) is indicated. 		K
FUEL PUMP RLY [ON/OFF]		×	<ul style="list-style-type: none"> Indicates the fuel pump relay control condition determined by ECM according to the input signals. 		L
VENT CONT/V [ON/OFF]			<ul style="list-style-type: none"> The control condition of the EVAP canister vent control valve (determined by ECM according to the input signals) is indicated. ON: Closed OFF: Open 		M
THRTL RELAY [ON/OFF]			<ul style="list-style-type: none"> Indicates the throttle control motor relay control condition determined by the ECM according to the input signals. 		
COOLING FAN [HI/OFF]			<ul style="list-style-type: none"> The control condition of the cooling fan (determined by ECM according to the input signals) is indicated. HI: High speed operation OFF: Stop 		
HO2S1 HTR (B1) [ON/OFF]			<ul style="list-style-type: none"> Indicates [ON/OFF] condition of heated oxygen sensor 1 heater determined by ECM according to the input signals. 		
HO2S1 HTR (B2) [ON/OFF]					

TROUBLE DIAGNOSIS

[VK45DE]

Monitored item [Unit]	ECM INPUT SIGNALS	MAIN SIGNALS	Description	Remarks
HO2S2 HTR (B1) [ON/OFF]			<ul style="list-style-type: none"> Indicates [ON/OFF] condition of heated oxygen sensor 2 heater determined by ECM according to the input signals. 	
HO2S2 HTR (B2) [ON/OFF]				
I/P PULLY SPD [rpm]			<ul style="list-style-type: none"> Indicates the engine speed computed from the turbine revolution sensor signal. 	
VEHICLE SPEED [km/h] or [MPH]			<ul style="list-style-type: none"> Indicates the vehicle speed computed from the revolution sensor signal. 	
IDL A/V LEARN [YET/CMPLT]			<ul style="list-style-type: none"> Display the condition of idle air volume learning YET: Idle air volume learning has not been performed yet. CMPLT: Idle air volume learning has already been performed successfully. 	
TRVL AFTER MIL [km] or [mile]			<ul style="list-style-type: none"> Distance traveled while MIL is activated. 	
O2SEN HTR DTY [%]			<ul style="list-style-type: none"> Indicates the heated oxygen sensor 1 heater control value computed by the ECM according to the input signals. 	
AC PRESS SEN [V]			<ul style="list-style-type: none"> The signal voltage from the refrigerant pressure sensor is displayed. 	
VHCL SPEED SE [km/h] or [mph]			<ul style="list-style-type: none"> The vehicle speed computed from the vehicle speed signal sent from TCM is displayed. 	
MAIN SW [ON/OFF]			<ul style="list-style-type: none"> Indicates [ON/OFF] condition from ON/OFF (MAIN) switch signal. 	
CANCEL SW [ON/OFF]			<ul style="list-style-type: none"> Indicates [ON/OFF] condition from CANCEL switch signal. 	
RESUME/ACC SW [ON/OFF]			<ul style="list-style-type: none"> Indicates [ON/OFF] condition from ACCEL/RESUME switch signal. 	
SET SW [ON/OFF]			<ul style="list-style-type: none"> Indicates [ON/OFF] condition from COAST/SET switch signal. 	
BRAKE SW1 [ON/OFF]			<ul style="list-style-type: none"> Indicates [ON/OFF] condition from ASCD brake switch signal. 	
BRAKE SW2 [ON/OFF]			<ul style="list-style-type: none"> Indicates [ON/OFF] condition of stop lamp switch signal. 	
DIST SW [ON/OFF]			<ul style="list-style-type: none"> Indicates [ON/OFF] condition from DISTANCE switch signal. 	
CRUISE LAMP [ON/OFF]			<ul style="list-style-type: none"> Indicates [ON/OFF] condition of CRUISE lamp determined by the ECM according to the input signals. 	
Voltage [V]			<ul style="list-style-type: none"> Voltage, frequency, duty cycle or pulse width measured by the probe. 	<ul style="list-style-type: none"> Only “#” is displayed if item is unable to be measured. Figures with “#”s are temporary ones. They are the same figures as an actual piece of data which was just previously measured.
Frequency [msec], [Hz] or [%]				
DUTY-HI				
DUTY-LOW				
PLS WIDTH-HI				
PLS WIDTH-LOW				

NOTE:

Any monitored item that does not match the vehicle being diagnosed is deleted from the display automatically.

TROUBLE DIAGNOSIS

[VK45DE]

DATA MONITOR (SPEC) MODE

Monitored Item

Monitored item [Unit]	ECM input signals	Main signals	Description	Remarks
ENG SPEED [rpm]	×	×	<ul style="list-style-type: none"> Indicates the engine speed computed from the signal of the crankshaft position sensor (POS) and camshaft position sensor (PHASE). 	
MAS A/F SE-B1 [V]	×	×	<ul style="list-style-type: none"> The signal voltage of the mass air flow sensor specification is displayed. 	<ul style="list-style-type: none"> When engine is running specification range is indicated.
B/FUEL SCHDL [msec]		×	<ul style="list-style-type: none"> "Base fuel schedule" indicates the fuel injection pulse width programmed into ECM, prior to any learned on board correction. 	<ul style="list-style-type: none"> When engine is running specification range is indicated.
A/F ALPHA-B1 [%] A/F ALPHA-B2 [%]		×	<ul style="list-style-type: none"> The mean value of the air-fuel ratio feedback correction factor per cycle is indicated. 	<ul style="list-style-type: none"> When engine is running specification range is indicated. This data also includes the data for the air-fuel ratio learning control.

NOTE:

Any monitored item that does not match the vehicle being diagnosed is deleted from the display automatically.

ACTIVE TEST MODE

Test Item

TEST ITEM	CONDITION	JUDGEMENT	CHECK ITEM (REMEDY)
FUEL INJECTION	<ul style="list-style-type: none"> Engine: Return to the original trouble condition Change the amount of fuel injection using CONSULT-II. 	If trouble symptom disappears, see CHECK ITEM.	<ul style="list-style-type: none"> Harness and connectors Fuel injector Heated oxygen sensor 1
IGNITION TIMING	<ul style="list-style-type: none"> Engine: Return to the original trouble condition Timing light: Set Retard the ignition timing using CONSULT-II. 	If trouble symptom disappears, see CHECK ITEM.	<ul style="list-style-type: none"> Perform Idle Air Volume Learning.
POWER BALANCE	<ul style="list-style-type: none"> Engine: After warming up, idle the engine. A/C switch OFF Shift lever: N Cut off each injector signal one at a time using CONSULT-II. 	Engine runs rough or dies.	<ul style="list-style-type: none"> Harness and connectors Compression Fuel injector Power transistor Spark plug Ignition coil
COOLING FAN*	<ul style="list-style-type: none"> Ignition switch: ON Turn the cooling fan "HI" and "OFF" using CONSULT-II. 	Cooling fan moves and stops.	<ul style="list-style-type: none"> Harness and connectors Cooling fan motor IPDM E/R
ENG COOLANT TEMP	<ul style="list-style-type: none"> Engine: Return to the original trouble condition Change the engine coolant temperature using CONSULT-II. 	If trouble symptom disappears, see CHECK ITEM.	<ul style="list-style-type: none"> Harness and connectors Engine coolant temperature sensor Fuel injector
FUEL PUMP RELAY	<ul style="list-style-type: none"> Ignition switch: ON (Engine stopped) Turn the fuel pump relay ON and OFF using CONSULT-II and listen to operating sound. 	Fuel pump relay makes the operating sound.	<ul style="list-style-type: none"> Harness and connectors Fuel pump relay

TROUBLE DIAGNOSIS

[VK45DE]

TEST ITEM	CONDITION	JUDGEMENT	CHECK ITEM (REMEDY)
VIAS SOL VALVE	<ul style="list-style-type: none"> ● Ignition switch: ON ● Turn solenoid valve ON and OFF with CONSULT-II and listen to operating sound. 	Solenoid valve makes an operating sound.	<ul style="list-style-type: none"> ● Harness and connectors ● Solenoid valve
PURG VOL CONT/V	<ul style="list-style-type: none"> ● Engine: After warming up, run engine at 1,500 rpm. ● Change the EVAP canister purge volume control solenoid valve opening percent using CONSULT-II. 	Engine speed changes according to the opening percent.	<ul style="list-style-type: none"> ● Harness and connectors ● Solenoid valve
FUEL/T TEMP SEN	<ul style="list-style-type: none"> ● Change the fuel tank temperature using CONSULT-II. 		
VENT CONTROL/V	<ul style="list-style-type: none"> ● Ignition switch: ON (Engine stopped) ● Turn solenoid valve ON and OFF with the CONSULT-II and listen to operating sound. 	Solenoid valve makes an operating sound.	<ul style="list-style-type: none"> ● Harness and connectors ● Solenoid valve
V/T ASSIGN ANGLE	<ul style="list-style-type: none"> ● Engine: Return to the original trouble condition ● Change intake valve timing using CONSULT-II. 	If trouble symptom disappears, see CHECK ITEM.	<ul style="list-style-type: none"> ● Harness and connectors ● Intake valve timing control solenoid valve

*: Leaving cooling fan OFF with CONSULT-II while engine is running may cause the engine to overheat.

DTC & SRT CONFIRMATION MODE

SRT STATUS Mode

For details, refer to [EC-709, "SYSTEM READINESS TEST \(SRT\) CODE"](#) .

SRT Work Support Mode

This mode enables a technician to drive a vehicle to set the SRT while monitoring the SRT status.

DTC Work Support Mode

Test mode	Test item	Condition	Reference page
EVAPORATIVE SYSTEM	PURG FLOW P0441	Refer to corresponding trouble diagnosis for DTC.	EC-976
	EVP SML LEAK P0442/P1442*		EC-981
	EVAP V/S LEAK P0456/P1456*		EC-1030
	PURG VOL CN/V P1444		EC-1160
HO2S1	HO2S1 (B1) P0133		EC-872
	HO2S1 (B1) P0134		EC-884
	HO2S1 (B1) P1143		EC-1103
	HO2S1 (B1) P1144		EC-1109
	HO2S1 (B2) P0153		EC-872
	HO2S1 (B2) P0154		EC-884
	HO2S1 (B2) P1163		EC-1103
	HO2S1 (B2) P1164		EC-1109
HO2S2	HO2S2 (B1) P0139	EC-903	
	HO2S2 (B1) P1146	EC-1116	
	HO2S2 (B1) P1147	EC-1127	
	HO2S2 (B2) P0159	EC-903	
	HO2S2 (B2) P1166	EC-1116	
	HO2S2 (B2) P1167	EC-1127	

*: DTC P1442 and P1456 does not apply to S50 models but appears in DTC Work Support Mode screens.

REAL TIME DIAGNOSIS IN DATA MONITOR MODE (RECORDING VEHICLE DATA)

Description

CONSULT-II has two kinds of triggers and they can be selected by touching "SETTING" in "DATA MONITOR" mode.

1. "AUTO TRIG" (Automatic trigger):

- The malfunction will be identified on the CONSULT-II screen in real time.

In other words, DTC/1st trip DTC and malfunction item will be displayed if the malfunction is detected by ECM.

At the moment a malfunction is detected by ECM, "MONITOR" in "DATA MONITOR" screen is changed to "Recording Data ... xx%" as shown at right, and the data after the malfunction detection is recorded. Then when the percentage reached 100%, "REAL-TIME DIAG" screen is displayed. If "STOP" is touched on the screen during "Recording Data ... xx%", "REAL-TIME DIAG" screen is also displayed.

The recording time after the malfunction detection and the recording speed can be changed by "TRIGGER POINT" and "Recording Speed". Refer to CONSULT-II OPERATION MANUAL.

DATA MONITOR	
Recording Data...11%	NO DTC
ENG SPEED	XXX rpm
MAS A/F SE-B1	XXX V
COOLAN TEMP/S	XXX °C
HO2S1 (B1)	XXX V
VHCL SPEED SE	XXX km/h

SEF705Y

2. "MANU TRIG" (Manual trigger):

- DTC/1st trip DTC and malfunction item will not be displayed automatically on CONSULT-II screen even though a malfunction is detected by ECM.

DATA MONITOR can be performed continuously even though a malfunction is detected.

SET RECORDING CONDITION
AUTO TRIG
MANU TRIG
TRIGGER POINT
<div style="display: flex; justify-content: space-between; align-items: center;"> <div style="width: 100%; border-bottom: 1px solid black; position: relative;"> <div style="position: absolute; left: 0; top: -5px; font-size: 8px;">0%</div> <div style="position: absolute; left: 20%; top: -5px; font-size: 8px;">20%</div> <div style="position: absolute; left: 40%; top: -5px; font-size: 8px;">40%</div> <div style="position: absolute; left: 60%; top: -5px; font-size: 8px;">60%</div> <div style="position: absolute; left: 80%; top: -5px; font-size: 8px;">80%</div> <div style="position: absolute; left: 100%; top: -5px; font-size: 8px;">100%</div> </div> </div>
RECORDING SPEED
<div style="display: flex; justify-content: space-between; align-items: center;"> <div style="width: 100%; border-bottom: 1px solid black; position: relative;"> <div style="position: absolute; left: 0; top: -5px; font-size: 8px;">MIN</div> <div style="position: absolute; right: 0; top: -5px; font-size: 8px;">MAX</div> </div> </div>
/64 /32 /16 /8 /4 /2 FULL

SEF707X

A
EC
C
D
E
F
G
H
I
J
K
L
M

Operation

1. "AUTO TRIG"

- While trying to detect the DTC/1st trip DTC by performing the "DTC Confirmation Procedure", be sure to select to "DATA MONITOR (AUTO TRIG)" mode. You can confirm the malfunction at the moment it is detected.
- While narrowing down the possible causes, CONSULT-II should be set in "DATA MONITOR (AUTO TRIG)" mode, especially in case the incident is intermittent. When you are inspecting the circuit by gently shaking (or twisting) the suspicious connectors, components and harness in the "DTC Confirmation Procedure", the moment a malfunction is found the DTC/1st trip DTC will be displayed. (Refer to "INCIDENT SIMULATION TESTS" in [GI-27, "How to Perform Efficient Diagnosis for an Electrical Incident"](#) .)

2. "MANU TRIG"

- If the malfunction is displayed as soon as "DATA MONITOR" is selected, reset CONSULT-II to "MANU TRIG". By selecting "MANU TRIG" you can monitor and store the data. The data can be utilized for further diagnosis, such as a comparison with the value for the normal operating condition.

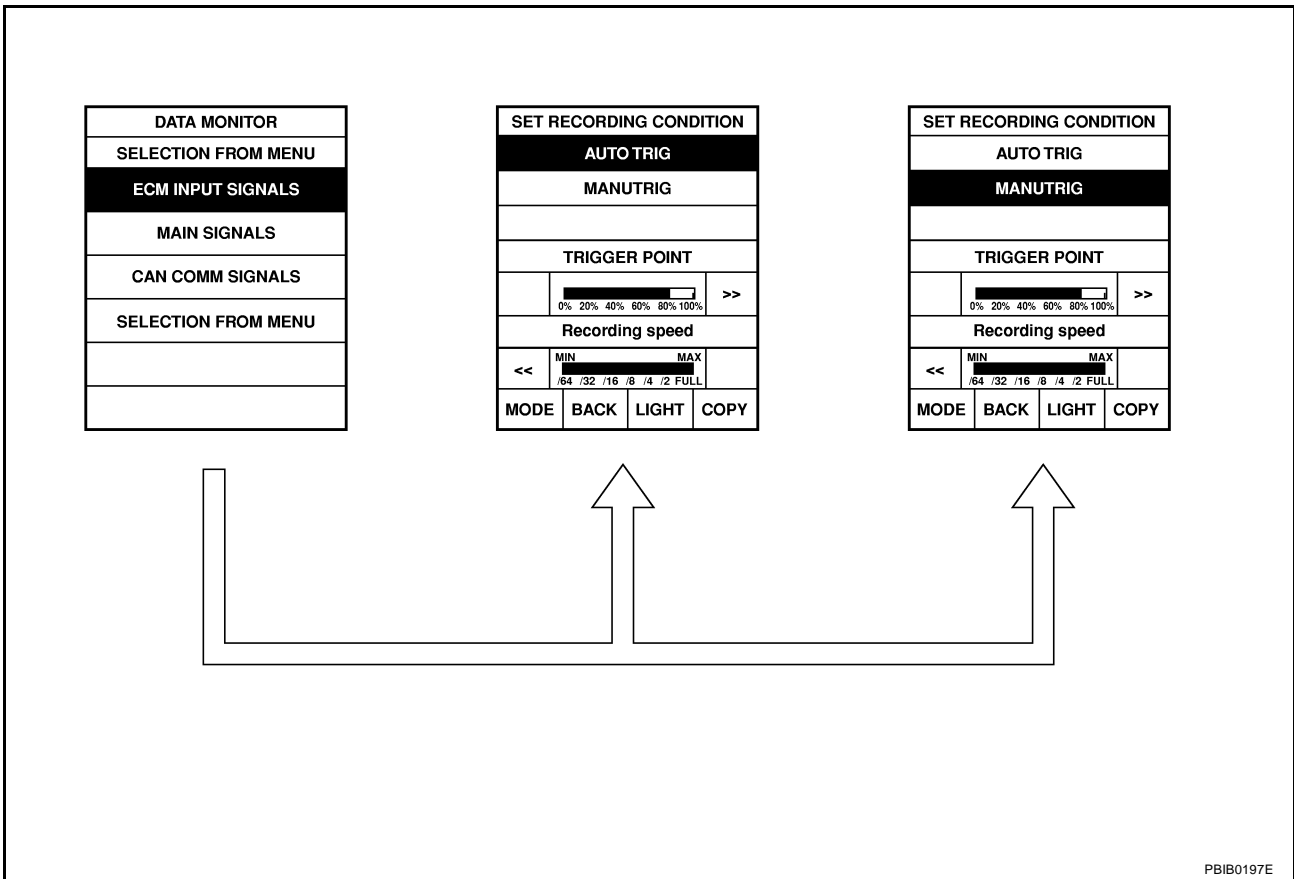

Generic Scan Tool (GST) Function DESCRIPTION

ABS00BZY

Generic Scan Tool (OBDII scan tool) complying with SAE J1978 has 8 different functions explained below. ISO9141 is used as the protocol. The name "GST" or "Generic Scan Tool" is used in this service manual.

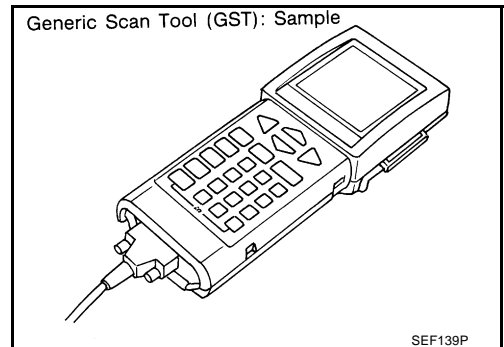

TROUBLE DIAGNOSIS

[VK45DE]

FUNCTION

Diagnostic test mode		Function
MODE 1	READINESS TESTS	This mode gains access to current emission-related data values, including analog inputs and outputs, digital inputs and outputs, and system status information.
MODE 2	(FREEZE DATA)	This mode gains access to emission-related data value which were stored by ECM during the freeze frame. For details, refer to EC-708, "FREEZE FRAME DATA AND 1ST TRIP FREEZE FRAME DATA" .
MODE 3	DTCs	This mode gains access to emission-related power train trouble codes which were stored by ECM.
MODE 4	CLEAR DIAG INFO	This mode can clear all emission-related diagnostic information. This includes: <ul style="list-style-type: none"> ● Clear number of diagnostic trouble codes (MODE 1) ● Clear diagnostic trouble codes (MODE 3) ● Clear trouble code for freeze frame data (MODE 1) ● Clear freeze frame data (MODE 2) ● Reset status of system monitoring test (MODE 1) ● Clear on board monitoring test results (MODE 6 and 7)
MODE 6	(ON BOARD TESTS)	This mode accesses the results of on board diagnostic monitoring tests of specific components/systems that are not continuously monitored.
MODE 7	(ON BOARD TESTS)	This mode enables the off board test drive to obtain test results for emission-related powertrain components/systems that are continuously monitored during normal driving conditions.
MODE 8	—	This mode can close EVAP system in ignition switch ON position (Engine stopped). When this mode is performed, EVAP canister vent control valve can be closed. In the following conditions, this mode cannot function. <ul style="list-style-type: none"> ● Low ambient temperature ● Low battery voltage ● Engine running ● Ignition switch OFF ● Low fuel temperature ● Too much pressure is applied to EVAP system
MODE 9	(CALIBRATION ID)	This mode enables the off-board test device to request specific vehicle information such as Vehicle Identification Number (VIN) and Calibration IDs.

INSPECTION PROCEDURE

1. Turn ignition switch OFF.
2. Connect "GST" to data link connector, which is located under LH dash panel near the hood opener handle.

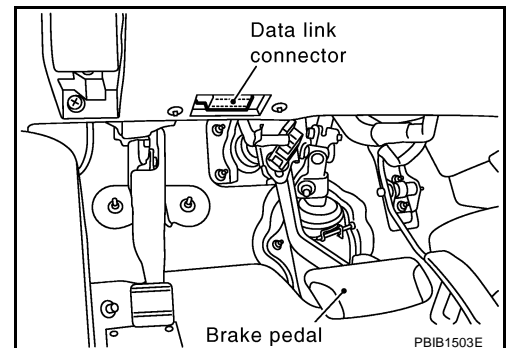

TROUBLE DIAGNOSIS

[VK45DE]

3. Turn ignition switch ON.
4. Enter the program according to instruction on the screen or in the operation manual.
(*: Regarding GST screens in this section, sample screens are shown.)

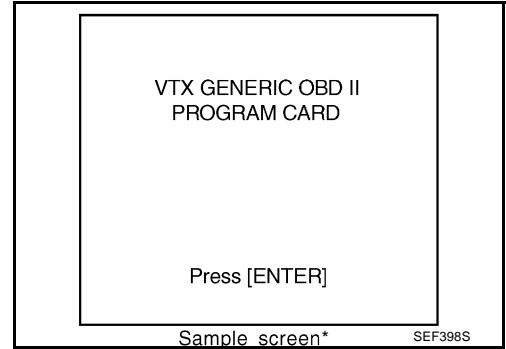

5. Perform each diagnostic mode according to each service procedure.
For further information, see the GST Operation Manual of the tool maker.

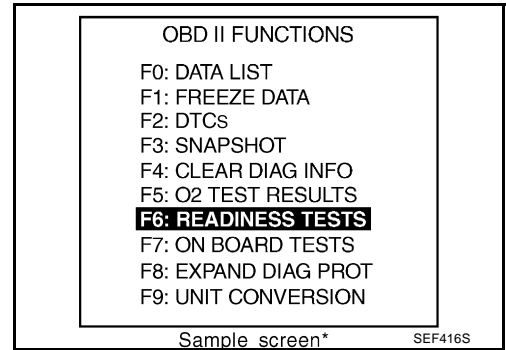

TROUBLE DIAGNOSIS

[VK45DE]

ABS00BZZ

CONSULT-II Reference Value in Data Monitor

Remarks:

● Specification data are reference values.

● Specification data are output/input values which are detected or supplied by the ECM at the connector.

* Specification data may not be directly related to their components signals/values/operations.

i.e. Adjust ignition timing with a timing light before monitoring IGN TIMING, because the monitor may show the specification data in spite of the ignition timing not being adjusted to the specification data. This IGN TIMING monitors the data calculated by the ECM according to the signals input from the camshaft position sensor and other ignition timing related sensors.

MONITOR ITEM	CONDITION		SPECIFICATION
ENG SPEED	● Run engine and compare the CONSULT-II value with tachometer indication		Almost the same speed as the tachometer indication
MAS A/F SE-B1	See EC-780, "TROUBLE DIAGNOSIS - SPECIFICATION VALUE" .		
B/FUEL SCHDL	See EC-780, "TROUBLE DIAGNOSIS - SPECIFICATION VALUE" .		
A/F ALPHA-B1 A/F ALPHA-B2	See EC-780, "TROUBLE DIAGNOSIS - SPECIFICATION VALUE" .		
COOLAN TEMP/S	● Engine: After warming up		More than 70°C (158°F)
HO2S1 (B1) HO2S1 (B2)	● Engine: After warming up	Maintaining engine speed at 2,000 rpm	0 - 0.3V ↔ Approx. 0.6 - 1.0V
HO2S2 (B1) HO2S2 (B2)	● Warm-up condition ● After keeping engine speed between 3,500 and 4,000 rpm for 1 minute and at idle for 1 minute under no load	Revving engine from idle to 3,000 rpm quickly	0 - 0.3V ↔ Approx. 0.6 - 1.0V
HO2S1 MNTR (B1) HO2S1 MNTR (B2)	● Engine: After warming up	Maintaining engine speed at 2,000 rpm	LEAN ↔ RICH Changes more than 5 times during 10 seconds
HO2S2 MNTR (B1) HO2S2 MNTR (B2)	● Warm-up condition ● After keeping engine speed between 3,500 and 4,000 rpm for 1 minute and at idle for 1 minute under no load	Revving engine from idle to 3,000 rpm quickly	LEAN ↔ RICH
VEH SPEED SE	● Turn drive wheels and compare the CONSULT-II value with speedometer indication		Almost the same speed as the speedometer indication
BATTERY VOLT	● Ignition switch: ON (Engine stopped)		11 - 14V
ACCEL SEN1	● Ignition switch: ON (Engine stopped)	Accelerator pedal: Fully released	0.5 - 1.0V
		Accelerator pedal: Fully depressed	4.0 - 4.7V
ACCEL SEN2*	● Ignition switch: ON (Engine stopped)	Accelerator pedal: Fully released	0.3 - 1.2V
		Accelerator pedal: Fully depressed	3.9 - 4.8V
THRTL SEN1 THRTL SEN2*	● Ignition switch: ON (Engine stopped) ● Shift lever: D	Accelerator pedal: Fully released	More than 0.36V
		Accelerator pedal: Fully depressed	Less than 4.75V
EVAP SYS PRES	● Ignition switch: ON		Approx. 1.8 - 4.8V
START SIGNAL	● Ignition switch: ON → START → ON		OFF → ON → OFF
CLSD THL POS	● Ignition switch: ON (Engine stopped)	Accelerator pedal: Fully released	ON
		Accelerator pedal: Slightly depressed	OFF
AIR COND SIG	● Engine: After warming up, idle the engine	Air conditioner switch: OFF	OFF
		Air conditioner switch: ON (Compressor operates)	ON
P/N POSI SW	● Ignition switch: ON	Shift lever: P or N	ON
		Shift lever: Except above	OFF
PW/ST SIGNAL	● Engine: After warming up, idle the engine	Steering wheel is in neutral position (Forward direction)	OFF
		Steering wheel is turned	ON

TROUBLE DIAGNOSIS

[VK45DE]

MONITOR ITEM	CONDITION	SPECIFICATION	
LOAD SIGNAL	● Ignition switch: ON	Rear window defogger switch is ON and/or lighting switch is in 2nd	ON
		Rear window defogger switch is OFF and lighting switch is OFF	OFF
SNOW MODE SW	● Ignition switch: ON	Snow mode switch: ON	ON
		Snow mode switch: OFF	OFF
IGNITION SW	● Ignition switch: ON → OFF → ON	ON → OFF → ON	
HEATER FAN SW	● Engine: After warming up, idle the engine	Heater fan is operating	ON
		Heater fan is not operating	OFF
BRAKE SW	● Ignition switch: ON	Brake pedal: Fully released	OFF
		Brake pedal: Slightly depressed	ON
INJ PULSE-B1 INJ PULSE-B2	● Engine: After warming up ● Air conditioner switch: OFF ● Shift lever: N ● No load	Idle	2.0 - 3.0 msec
		2,000 rpm	1.9 - 2.9 msec
IGN TIMING	● Engine: After warming up ● Air conditioner switch: OFF ● Shift lever: N ● No load	Idle	10° - 14° BTDC
		2,000 rpm	25° - 45° BTDC
CAL/LD VALUE	● Engine: After warming up ● Air conditioner switch: OFF ● Shift lever: N ● No load	Idle	14% - 33%
		2,500 rpm	12% - 25%
MASS AIRFLOW	● Engine: After warming up ● Air conditioner switch: OFF ● Shift lever: N ● No load	Idle	2.0 - 6.0 g-m/s
		2,500 rpm	7.0 - 20.0 g-m/s
PURG VOL C/V	● Engine: After warming up ● Air conditioner switch: OFF ● Shift lever: N ● No load	Idle	0%
		2,000 rpm	—
INT/V TIM (B1) INT/V TIM (B2)	● Engine: After warming up ● Air conditioner switch: OFF ● Shift lever: N ● No load	Idle	-5° - 5°CA
		2,000 rpm	Approx. 0° - 20°CA
INT/V SOL (B1) INT/V SOL (B2)	● Engine: After warming up ● Air conditioner switch: OFF ● Shift lever: N ● No load	Idle	0% - 2%
		2,000 rpm	Approx. 25% - 50%
VIAS S/V	● Engine speed: Idle	Shift lever position: P or N	ON
		Except above	OFF
AIR COND RLY	● Engine: After warming up, idle the engine	Air conditioner switch: OFF	OFF
		Air conditioner switch: ON (Compressor operates)	ON
FUEL PUMP RLY	● For 1 second after turning ignition switch ON	ON	
	● Engine running or cranking ● Except above conditions	OFF	

TROUBLE DIAGNOSIS

[VK45DE]

MONITOR ITEM	CONDITION	SPECIFICATION
VENT CONT/V	● Ignition switch: ON	OFF
THRTL RELAY	● Ignition switch: ON	ON
COOLING FAN	● Engine: After warming up, idle the engine ● Air conditioner switch: OFF	Engine coolant temperature is 94°C (201°F) or less OFF
		Engine coolant temperature is 95°C (203°F) or more HI
HO2S1 HTR (B1) HO2S1 HTR (B2)	● Engine: After warming up ● Engine speed: Below 3,000 rpm	ON
	● Engine speed: Above 3,000 rpm	OFF
HO2S2 HTR (B1) HO2S2 HTR (B2)	● Engine speed is below 3,600 rpm after the following conditions are met. – Engine: After warming up – Keeping the engine speed between 3,500 and 4,000 rpm for 1 minute and at idle for 1 minute under no load	ON
	● Engine speed: Above 3,600 rpm	OFF
I/P PULLY SPD	● Vehicle speed: More than 20 km/h (12 MPH)	Almost the same speed as the tachometer indication
VEHICLE SPEED	● Turn drive wheels and compare the CONSULT-II value with speedometer indication	Almost the same speed as the speedometer indication
TRVL AFTER MIL	● Ignition switch: ON	Vehicle has traveled after MIL has turned ON. 0 - 65,535 km (0 - 40,723 miles)
O2SEN HTR DTY	● Engine coolant temperature when engine started: More than 80°C (176°F) ● Engine speed: Below 3,000 rpm	Approx. 40%
AC PRESS SEN	● Engine: Idle ● Both A/C switch and blower fan switch: ON (Compressor operates)	1.0 - 4.0V
VEH SPEED SE	● Turn drive wheels and compare the CONSULT-II value with speedometer indication	Almost the same speed as the speedometer indication
SET VHCL SPD	● Engine: Running	ASCD: Operating The preset vehicle speed is displayed
MAIN SW	● Ignition switch: ON	ON/OFF (MAIN) switch: Pressed ON
		ON/OFF (MAIN) switch: Released OFF
CANCEL SW	● Ignition switch: ON	CANCEL switch: Pressed ON
		CANCEL switch: Released OFF
RESUME/ACC SW	● Ignition switch: ON	ACCEL/RESUME switch: Pressed ON
		ACCEL/RESUME switch: Released OFF
SET SW	● Ignition switch: ON	COAST/SET switch: Pressed ON
		COAST/SET switch: Released OFF
BRAKE SW1	● Ignition switch: ON	Brake pedal: Fully released ON
		Brake pedal: Slightly depressed OFF
BRAKE SW2	● Ignition switch: ON	Brake pedal: Fully released OFF
		Brake pedal: Slightly depressed ON
DIST SW	● Ignition switch: ON	DISTANCE switch: Pressed ON
		DISTANCE switch: Released OFF
CRUISE LAMP	● Ignition switch: ON	ON/OFF (MAIN) switch: Pressed at the 1st time → at the 2nd time ON → OFF
SET LAMP	● Ignition switch: ON	ASCD is operating ON
		ASCD is not operating OFF

A
EC
C
D
E
F
G
H
I
J
K
L
M

*: Accelerator pedal position sensor 2 signal and throttle position sensor 2 signal are converted by ECM internally. Thus, they differ from ECM terminals voltage signal.

Major Sensor Reference Graph in Data Monitor Mode

The following are the major sensor reference graphs in "DATA MONITOR" mode.

CLSD THL POS, ACCEL SEN 1, THRTL SEN 1

Below is the data for "CLSD THL POS", "ACCEL SEN 1" and "THRTL SEN 1" when depressing the accelerator pedal with the ignition switch ON and with selector lever in D position.

The signal of "ACCEL SEN 1" and "THRTL SEN 1" should rise gradually without any intermittent drop or rise after "CLSD THL POS" is changed from "ON" to "OFF".

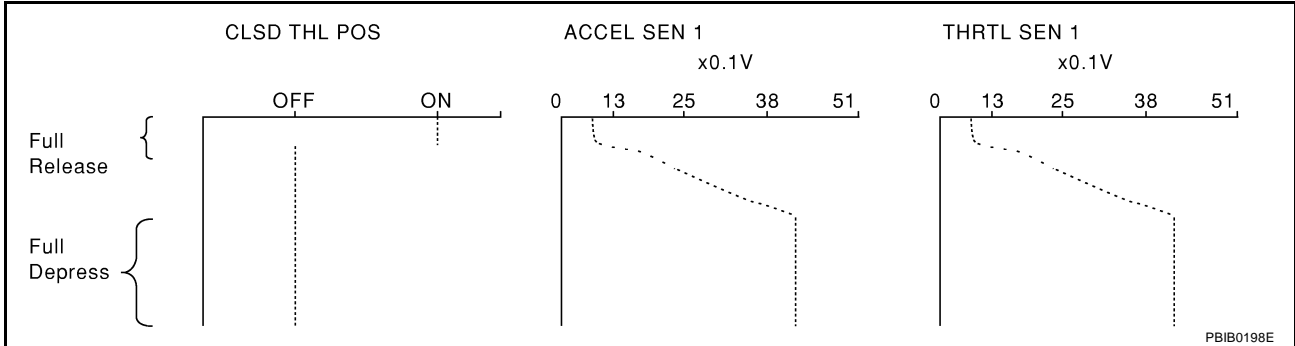

ENG SPEED, MAS A/F SE-B1, THRTL SEN 1, HO2S2 (B1), HO2S1 (B1), INJ PULSE-B1

Below is the data for "ENG SPEED", "MAS A/F SE-B1", "THRTL SEN 1", "HO2S2 (B1)", "HO2S1 (B1)" and "INJ PULSE-B1" when revving engine quickly up to 4,800 rpm under no load after warming up engine sufficiently.

Each value is for reference, the exact value may vary.

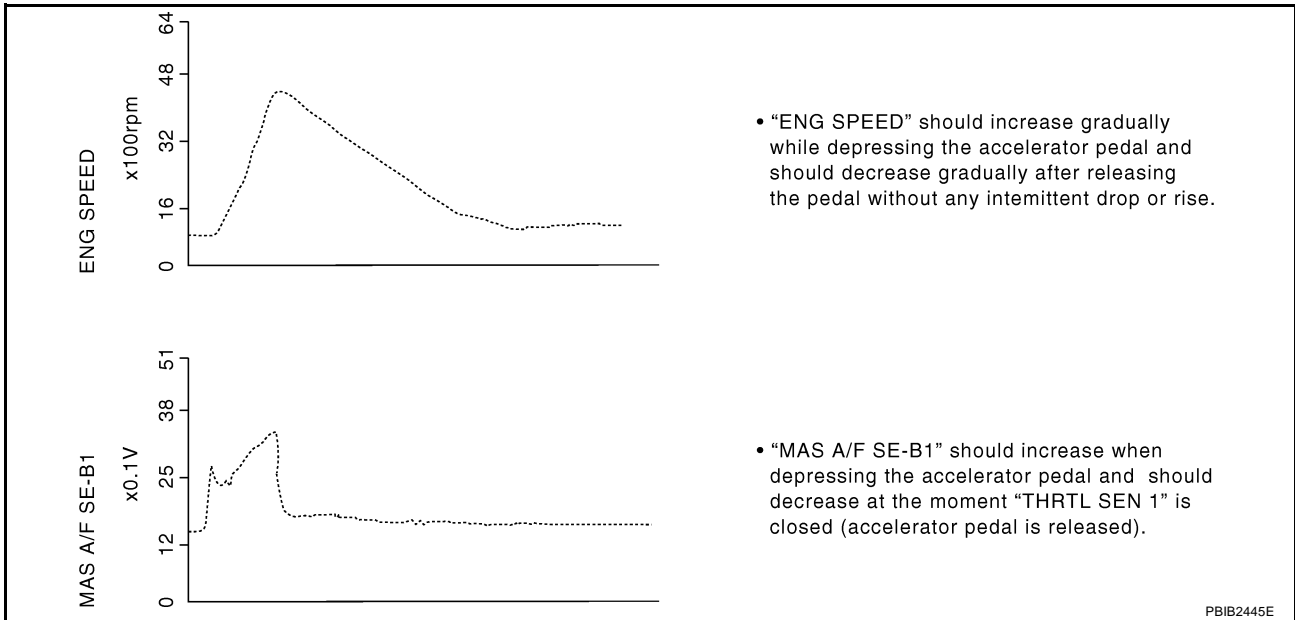

A
EC
C
D
E
F
G
H
I
J
K
L
M

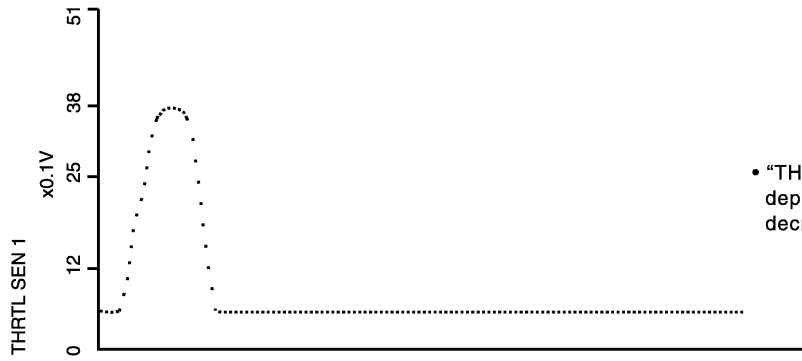

- "THRTL SEN 1" should increase while depressing the accelerator pedal and should decrease while releasing it.



- "HO2S2 (B1)" may increase immediately after depressing the accelerator pedal and may decrease after releasing the pedal.

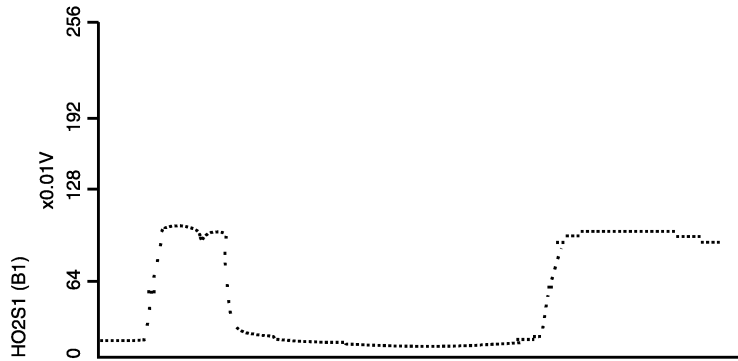

- "HO2S1 (B1)" may increase immediately after depressing the accelerator pedal and may decrease after releasing the pedal.

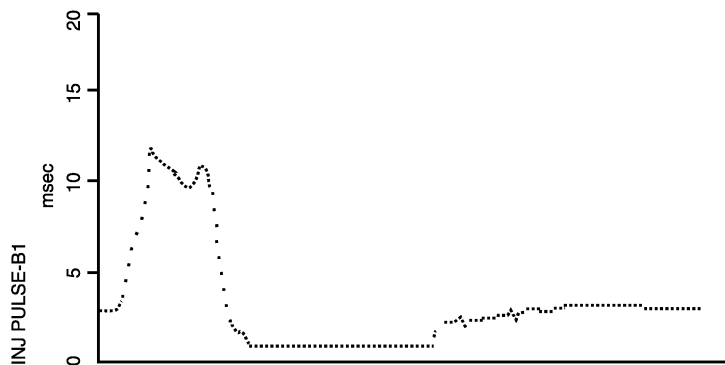

- "INJ PULSE-B1" should increase when depressing the accelerator pedal and should decrease when the pedal is released.

PBIB0668E

TROUBLE DIAGNOSIS - SPECIFICATION VALUE

PFP:00031

Description

ABS00C01

The specification (SP) value indicates the tolerance of the value that is displayed in "DATA MONITOR (SPEC)" mode of CONSULT-II during normal operation of the Engine Control System. When the value in "DATA MONITOR (SPEC)" mode is within the SP value, the Engine Control System is confirmed OK. When the value in "DATA MONITOR (SPEC)" mode is NOT within the SP value, the Engine Control System may have one or more malfunctions.

The SP value is used to detect malfunctions that may affect the Engine Control System, but will not light the MIL.

The SP value will be displayed for the following three items:

- B/FUEL SCHDL (The fuel injection pulse width programmed into ECM prior to any learned on board correction)
- A/F ALPHA-B1/B2 (The mean value of air-fuel ratio feedback correction factor per cycle)
- MAS A/F SE-B1 (The signal voltage of the mass air flow sensor)

Testing Condition

ABS00C02

- Vehicle driven distance: More than 5,000 km (3,017 miles)
- Barometric pressure: 98.3 - 104.3 kPa (1.003 - 1.064 kg/cm², 14.25 - 15.12 psi)
- Atmospheric temperature: 20 - 30°C (68 - 86°F)
- Engine coolant temperature: 75 - 95°C (167 - 203°F)
- Transmission: Warmed-up*¹
- Electrical load: Not applied*²
- Engine speed: Idle

*1: After the engine is warmed up to normal operating temperature, drive vehicle until "FLUID TEMP SE" (A/T fluid temperature sensor signal) indicates more than 60°C (140°F).

*2: Rear window defogger switch, air conditioner switch, lighting switch are OFF. Steering wheel is straight ahead.

Inspection Procedure

ABS00C03

NOTE:

Perform "DATA MONITOR (SPEC)" mode in maximum scale display.

1. Perform [EC-733, "Basic Inspection"](#) .
2. Confirm that the testing conditions indicated above are met.
3. Select "B/FUEL SCHDL", "A/F ALPHA-B1", "A/F ALPHA-B2" and "MAS A/F SE-B1" in "DATA MONITOR (SPEC)" mode with CONSULT-II.
4. Make sure that monitor items are within the SP value.
5. If NG, go to [EC-781, "Diagnostic Procedure"](#) .

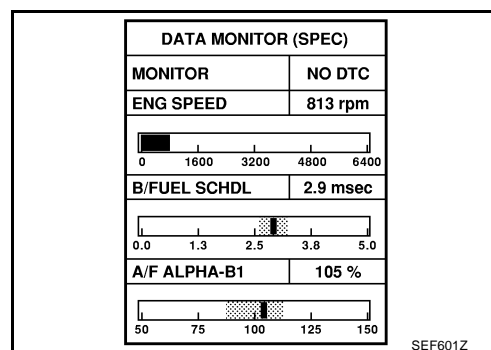

Diagnostic Procedure

ABS00C04

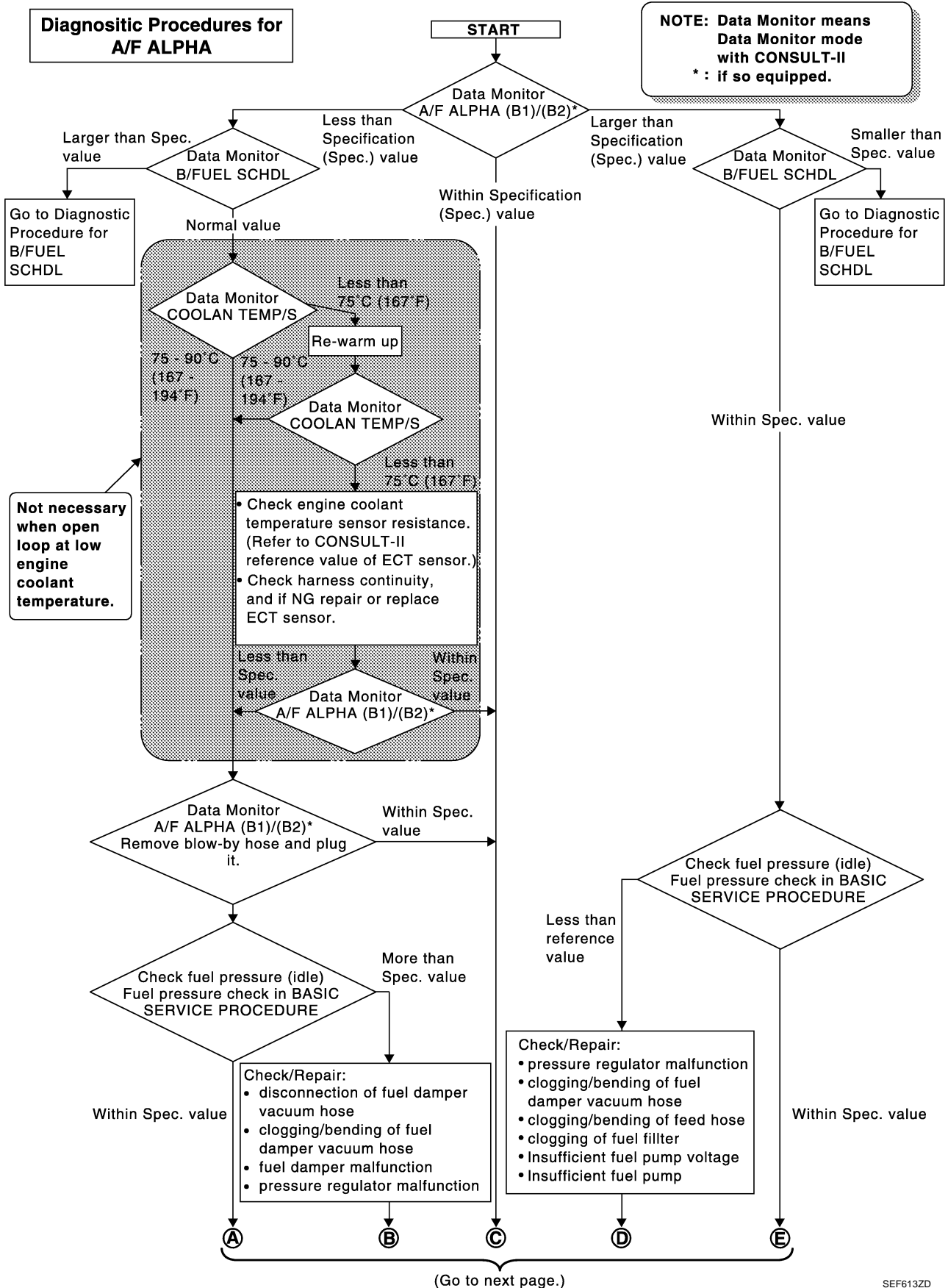

A
EC
C
D
E
F
G
H
I
J
K
L
M

TROUBLE DIAGNOSIS - SPECIFICATION VALUE

[VK45DE]

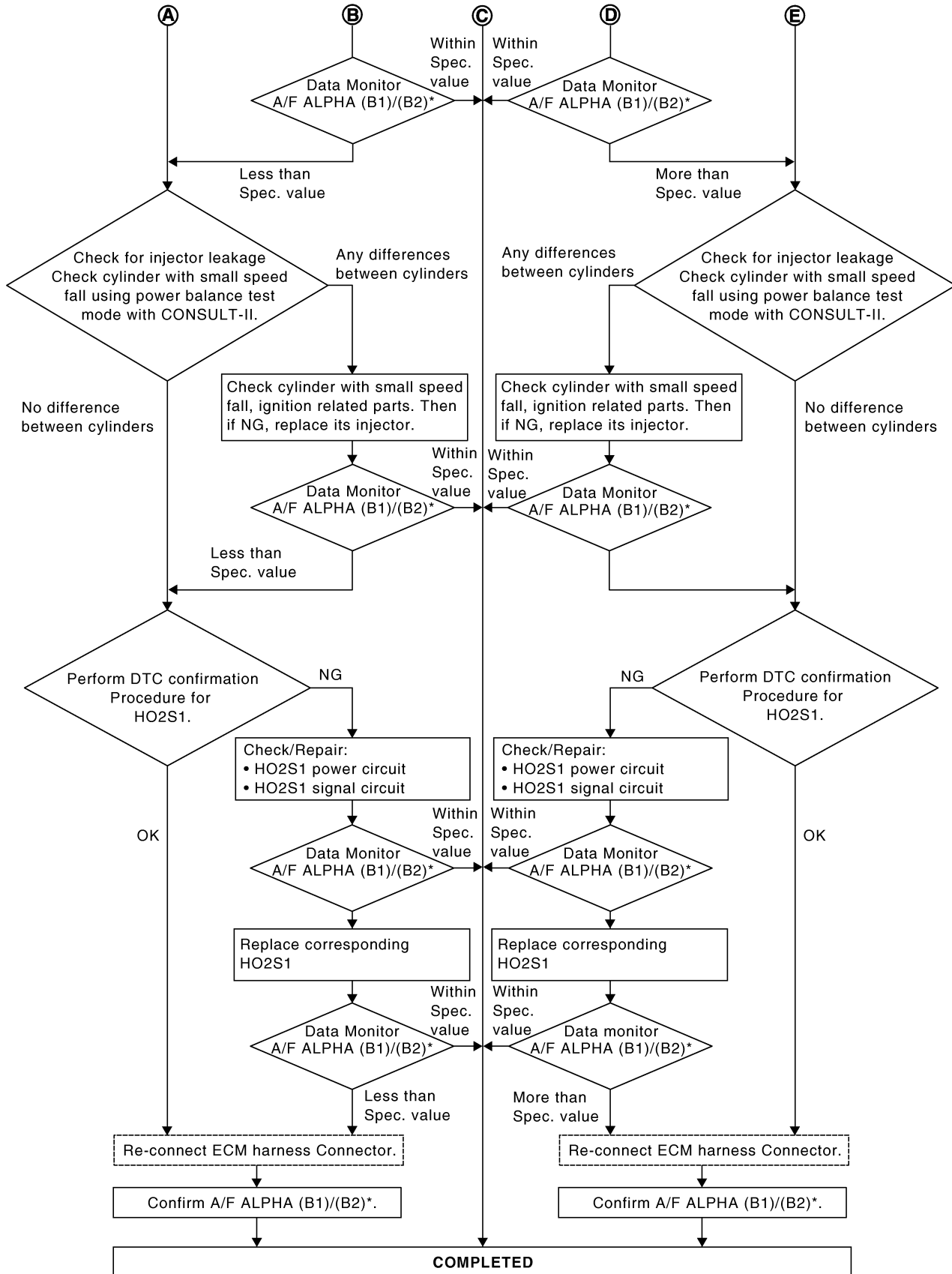

SEF768Z

TROUBLE DIAGNOSIS - SPECIFICATION VALUE

[VK45DE]

A
EC
C
D
E
F
G
H
I
J
K
L
M

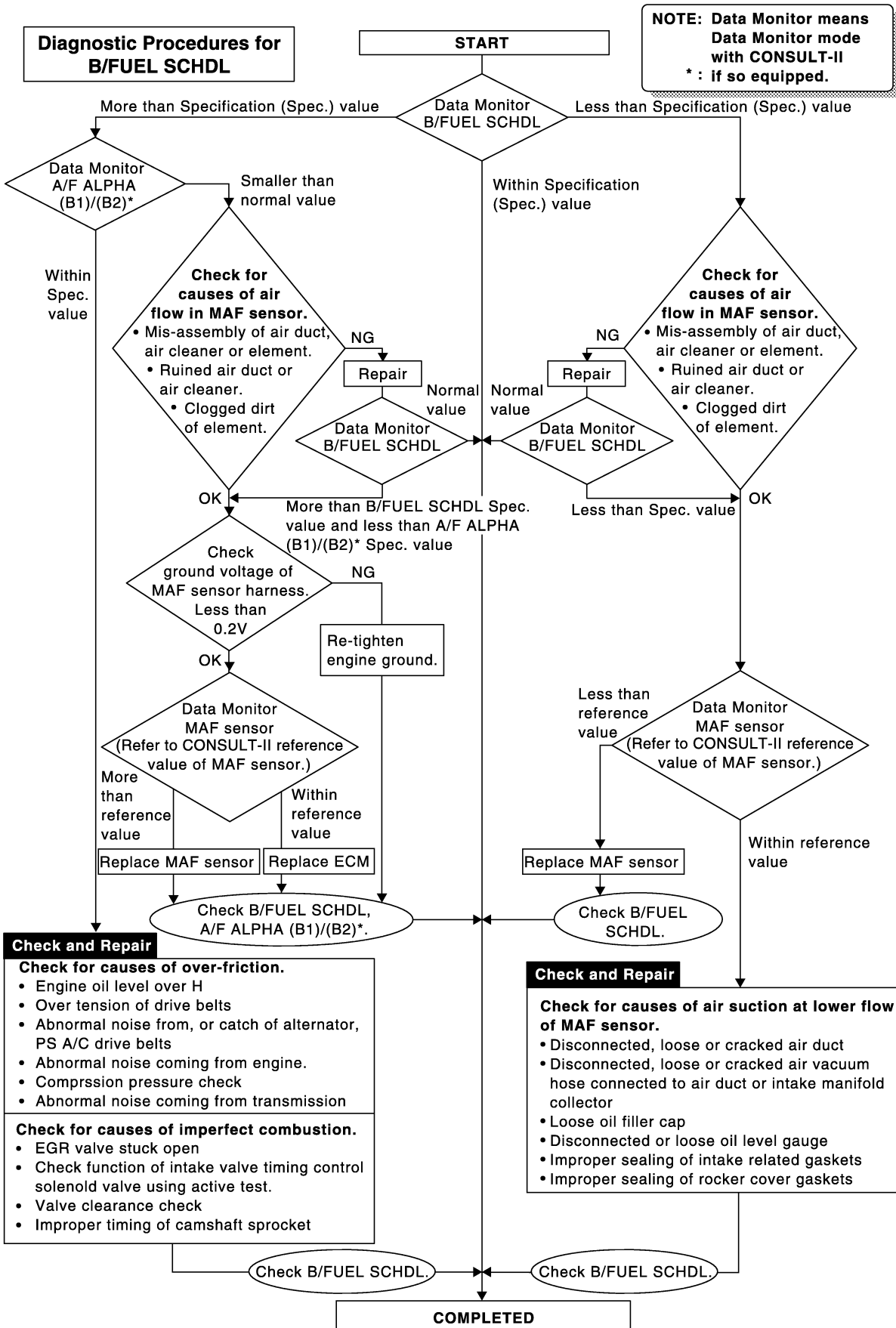

SEF615ZA

TROUBLE DIAGNOSIS FOR INTERMITTENT INCIDENT

PFP:00006

Description

ABS00C05

Intermittent incidents (I/I) may occur. In many cases, the malfunction resolves itself (the part or circuit function returns to normal without intervention). It is important to realize that the symptoms described in the customer's complaint often do not recur on (1st trip) DTC visits. Realize also that the most frequent cause of I/I occurrences is poor electrical connections. Because of this, the conditions under which the incident occurred may not be clear. Therefore, circuit checks made as part of the standard diagnostic procedure may not indicate the specific malfunctioning area.

Common I/I Report Situations

STEP in Work Flow	Situation
II	The CONSULT-II is used. The SELF-DIAG RESULTS screen shows time data other than [0] or [1t].
III	The symptom described by the customer does not recur.
IV	(1st trip) DTC does not appear during the DTC Confirmation Procedure.
VI	The Diagnostic Procedure for PXXXX does not indicate the malfunctioning area.

Diagnostic Procedure

ABS00C06

1. INSPECTION START

Erase (1st trip) DTCs. Refer to [EC-715, "HOW TO ERASE EMISSION-RELATED DIAGNOSTIC INFORMATION"](#) .

>> GO TO 2.

2. CHECK GROUND TERMINALS

Check ground terminals for corroding or loose connection.

Refer to [GI-27, "How to Perform Efficient Diagnosis for an Electrical Incident"](#) , "CIRCUIT INSPECTION", "Ground Inspection".

OK or NG

OK >> GO TO 3.

NG >> Repair or replace.

3. SEARCH FOR ELECTRICAL INCIDENT

Perform [GI-27, "How to Perform Efficient Diagnosis for an Electrical Incident"](#) , "INCIDENT SIMULATION TESTS".

OK or NG

OK >> GO TO 4.

NG >> Repair or replace.

4. CHECK CONNECTOR TERMINALS

Refer to [GI-24, "How to Check Terminal"](#) , "HOW TO PROBE CONNECTORS", "How to Check Enlarged Contact Spring of Terminal".

OK or NG

OK >> **INSPECTION END**

NG >> Repair or replace connector.

POWER SUPPLY AND GROUND CIRCUIT

[VK45DE]

POWER SUPPLY AND GROUND CIRCUIT

PPF:24110

Wiring Diagram

ABS00C07

EC-MAIN-01

— : DETECTABLE LINE FOR DTC
 — : NON-DETECTABLE LINE FOR DTC

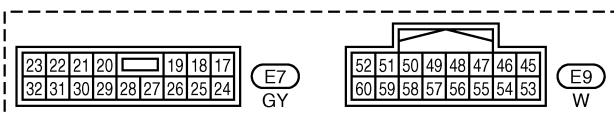
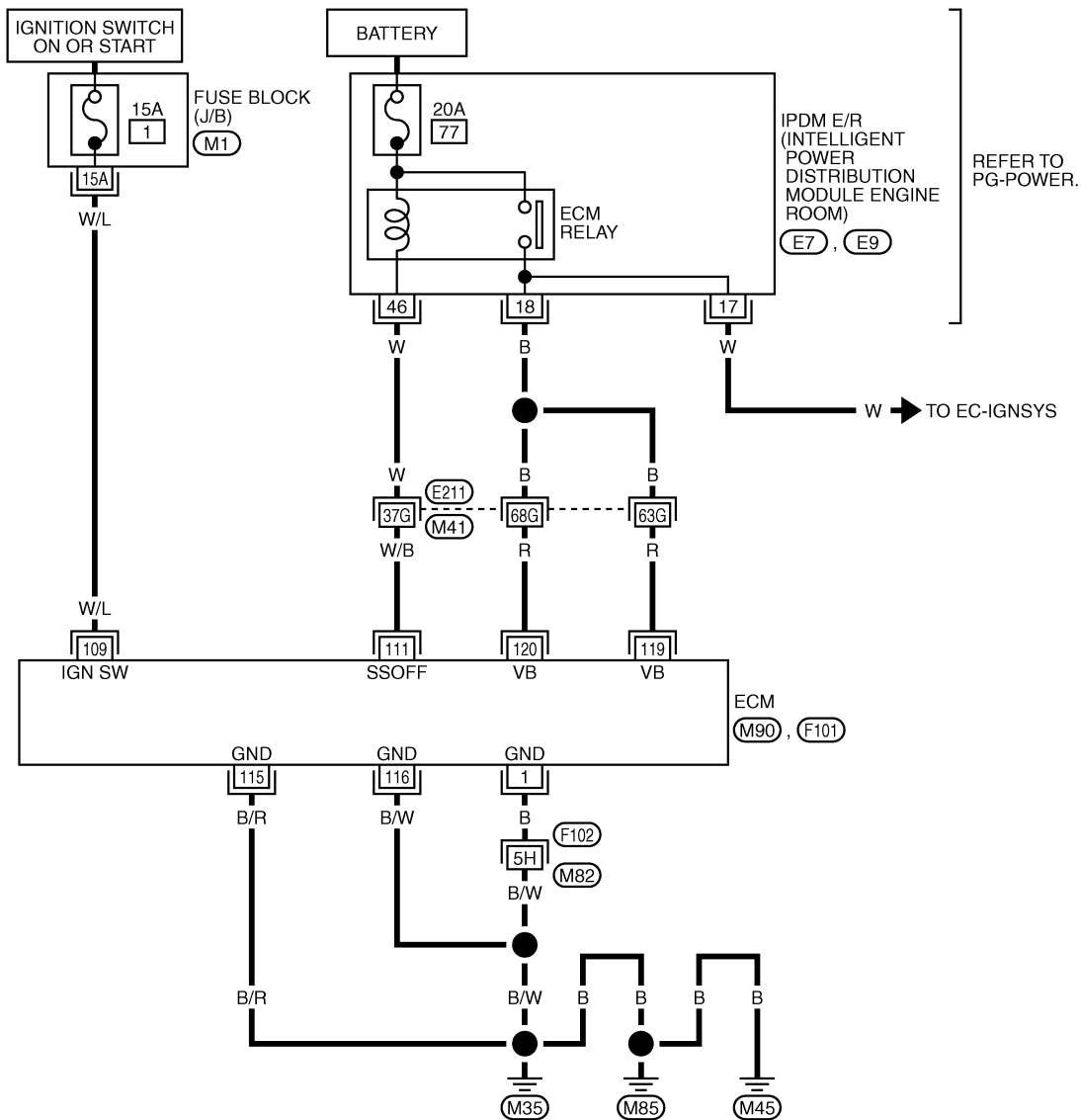

REFER TO THE FOLLOWING.
 (E211), (F102) -SUPER MULTIPLE JUNCTION (SMJ)
 (M1) -FUSE BLOCK-JUNCTION BOX (J/B)

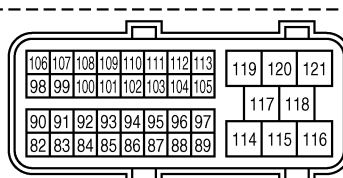
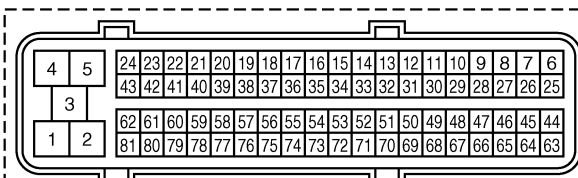

TBWM0217E

POWER SUPPLY AND GROUND CIRCUIT

[VK45DE]

Specification data are reference values and are measured between each terminal and ground.

CAUTION:

Do not use ECM ground terminals when measuring input/output voltage. Doing so may result in damage to the ECM's transistor. Use a ground other than ECM terminals, such as the ground.

TER-MINAL NO.	WIRE COLOR	ITEM	CONDITION	DATA (DC Voltage)
1	B	ECM ground	[Engine is running] ● Idle speed	Body ground
109	W/L	Ignition switch	[Ignition switch: OFF]	0V
			[Ignition switch: ON]	BATTERY VOLTAGE (11 - 14V)
111	W/B	ECM relay (Self shut-off)	[Engine is running] [Ignition switch: OFF] ● For a few seconds after turning ignition switch OFF	0 - 1.5V
			[Ignition switch: OFF] ● More than a few seconds after turning ignition switch OFF	BATTERY VOLTAGE (11 - 14V)
115 116	B/R B/W	ECM ground	[Engine is running] ● Idle speed	Body ground
119 120	R R	Power supply for ECM	[Ignition switch: ON]	BATTERY VOLTAGE (11 - 14V)

Diagnostic Procedure

ABS00C08

1. INSPECTION START

Start engine.

Is engine running?

Yes or No

- Yes >> GO TO 8.
- No >> GO TO 2.

2. CHECK ECM POWER SUPPLY CIRCUIT-I

1. Turn ignition switch OFF and then ON.
2. Check voltage between ECM terminal 109 and ground with CONSULT-II or tester.

Voltage: Battery voltage

OK or NG

- OK >> GO TO 4.
- NG >> GO TO 3.

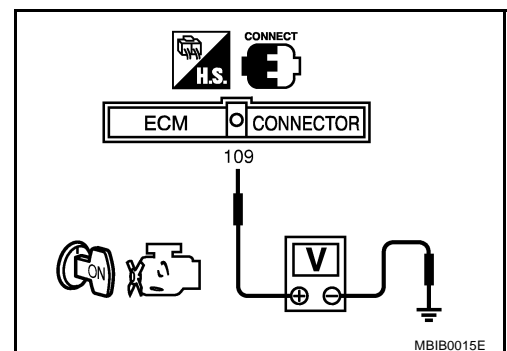

3. DETECT MALFUNCTIONING PART

Check the following.

- Fuse block (J/B) connector M1
- 15A fuse
- Harness for open or short between ECM and fuse

>> Repair open circuit or short to ground or short to power in harness or connectors.

4. CHECK GROUND CONNECTIONS

1. Turn ignition switch OFF.
2. Loosen and retighten three ground screws on the body.
Refer to [EC-791, "Ground Inspection"](#) .

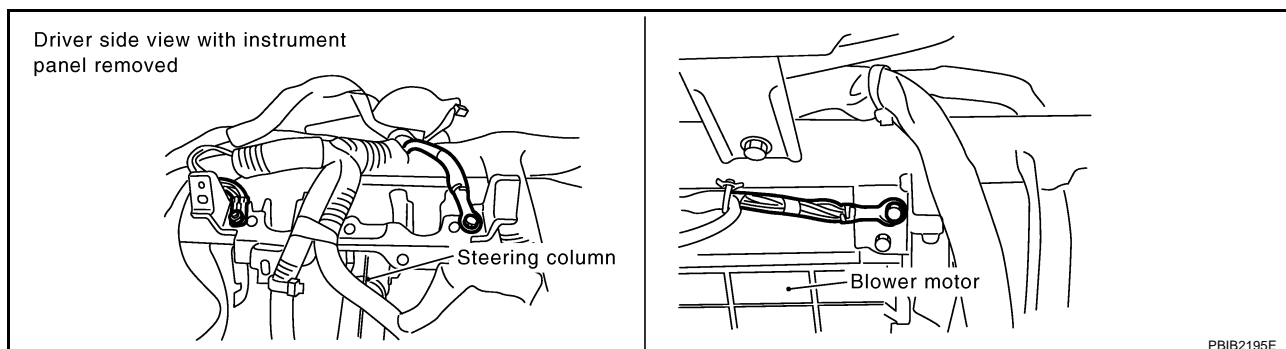

OK or NG

- OK >> GO TO 5.
NG >> Repair or replace ground connections.

5. CHECK ECM GROUND CIRCUIT FOR OPEN AND SHORT-I

1. Disconnect ECM harness connector.
2. Check harness continuity between ECM terminals 1, 115, 116 and ground.
Refer to Wiring Diagram.

Continuity should exist.

3. Also check harness for short to power.

OK or NG

- OK >> GO TO 7.
NG >> GO TO 6.

6. DETECT MALFUNCTIONING PART

Check the following.

- Harness connectors F102, M82
- Harness for open or short between ECM and ground

>> Repair open circuit or short to power in harness or connectors.

7. CHECK ECM POWER SUPPLY CIRCUIT-II

1. Reconnect ECM harness connector.
2. Turn ignition switch ON.
3. Check voltage between IPDM E/R terminal 17 and ground with CONSULT-II or tester.

Voltage: Battery voltage

OK or NG

- OK >> Go to [EC-1262, "IGNITION SIGNAL"](#) .
 NG >> GO TO 8.

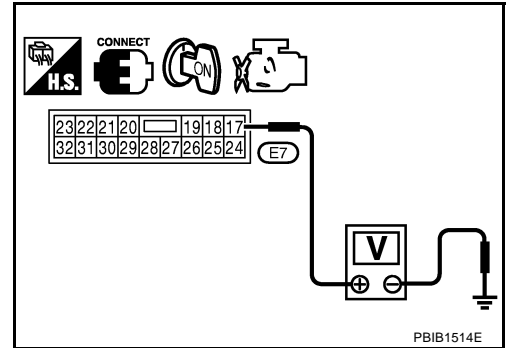

8. CHECK ECM POWER SUPPLY CIRCUIT-III

1. Turn ignition switch OFF and wait at least 10 seconds.
2. Turn ignition switch ON and then OFF.
3. Check voltage between ECM terminals 119, 120 and ground with CONSULT-II or tester.

Voltage: After turning ignition switch OFF, battery voltage will exist for a few seconds, then drop approximately 0V.

OK or NG

- OK >> GO TO 18.
 NG (Battery voltage does not exist.)>>GO TO 9.
 NG (Battery voltage exists for more than a few seconds.)>>GO TO 18.

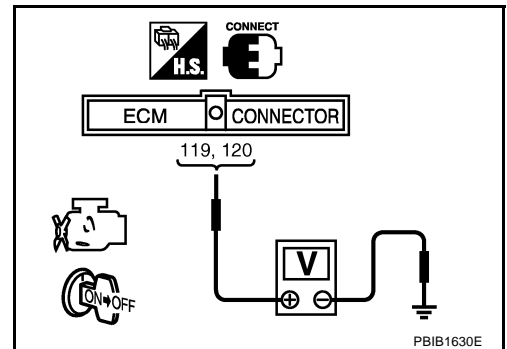

9. CHECK ECM POWER SUPPLY CIRCUIT-IV

1. Turn ignition switch OFF and wait at least 10 seconds.
2. Check voltage between ECM terminal 111 and ground with CONSULT-II or tester.

Voltage: Battery voltage

OK or NG

- OK >> GO TO 10.
 NG >> GO TO 12.

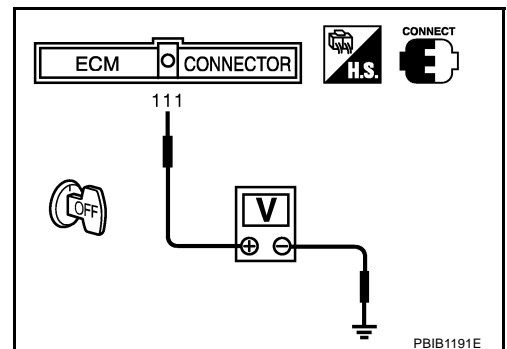

10. CHECK ECM POWER SUPPLY CIRCUIT-V

1. Disconnect ECM harness connector.
2. Disconnect IPDM E/R harness connector E7.
3. Check harness continuity between ECM terminals 119, 120 and IPDM E/R terminal 18.
Refer to Wiring Diagram.

Continuity should exist.

4. Also check harness for short to ground and short to power.

OK or NG

- OK >> GO TO 15.
NG >> GO TO 11.

11. DETECT MALFUNCTIONING PART

Check the following.

- Harness or connectors E211, M41
- Harness for open or short between ECM and IPDM E/R

>> Repair open circuit or short to ground or short to power in harness or connectors.

12. CHECK ECM POWER SUPPLY CIRCUIT-VI

1. Disconnect ECM harness connector.
2. Disconnect IPDM E/R harness connector E9.
3. Check harness continuity between ECM terminal 111 and IPDM E/R terminal 46.
Refer to Wiring Diagram.

Continuity should exist.

4. Also check harness for short to ground and short to power.

OK or NG

- OK >> GO TO 14.
NG >> GO TO 13.

13. DETECT MALFUNCTIONING PART

Check the following.

- Harness or connectors E211, M41
- Harness for open or short between ECM and IPDM E/R

>> Repair open circuit or short to ground or short to power in harness or connectors.

14. CHECK 20A FUSE

1. Disconnect 20A fuse from IPDM E/R.
2. Check 20A fuse.

OK or NG

- OK >> GO TO 18.
NG >> Replace 20A fuse.

A

EC

C

D

E

F

G

H

I

J

K

L

M

15. CHECK GROUND CONNECTIONS

- Loosen and retighten three ground screws on the body.
Refer to [EC-791, "Ground Inspection"](#) .

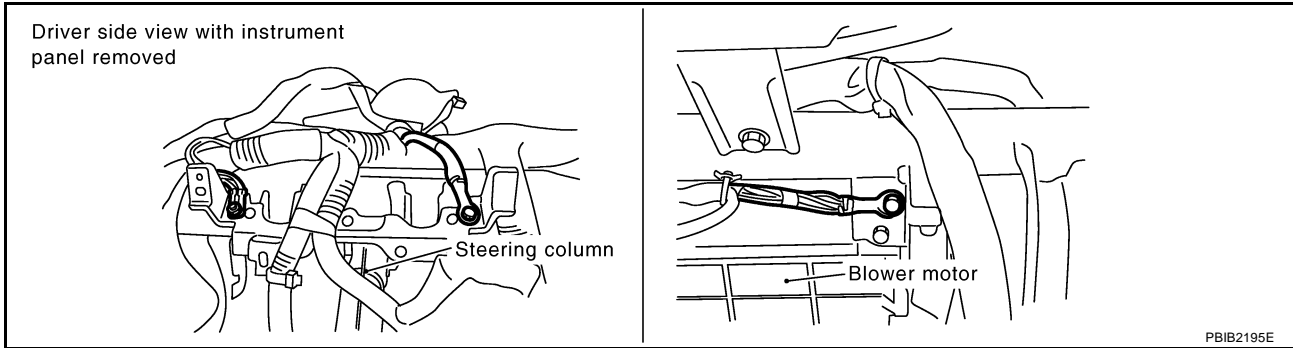

OK or NG

- OK >> GO TO 16.
NG >> Repair or replace ground connections.

16. CHECK ECM GROUND CIRCUIT FOR OPEN AND SHORT-II

- Disconnect ECM harness connector.
- Check harness continuity between ECM terminals 1, 115, 116 and ground.
Refer to Wiring Diagram.

Continuity should exist.

- Also check harness for short to power.

OK or NG

- OK >> GO TO 18.
NG >> GO TO 17.

17. DETECT MALFUNCTIONING PART

Check the following.

- Harness or connectors F102, M82
- Harness for open or short between ECM and ground

>> Repair open circuit or short to power in harness or connectors.

18. CHECK INTERMITTENT INCIDENT

Refer to [EC-784, "TROUBLE DIAGNOSIS FOR INTERMITTENT INCIDENT"](#) .

OK or NG

- OK >> Replace IPDM E/R.
NG >> Repair open circuit or short to power in harness or connectors.

Ground Inspection

Ground connections are very important to the proper operation of electrical and electronic circuits. Ground connections are often exposed to moisture, dirt and other corrosive elements. The corrosion (rust) can become an unwanted resistance. This unwanted resistance can change the way a circuit works.

Electronically controlled circuits are very sensitive to proper grounding. A loose or corroded ground can drastically affect an electronically controlled circuit. A poor or corroded ground can easily affect the circuit. Even when the ground connection looks clean, there can be a thin film of rust on the surface.

When inspecting a ground connection follow these rules:

- Remove the ground bolt or screw.
- Inspect all mating surfaces for tarnish, dirt, rust, etc.
- Clean as required to assure good contact.
- Reinstall bolt or screw securely.
- Inspect for "add-on" accessories which may be interfering with the ground circuit.
- If several wires are crimped into one ground eyelet terminal, check for proper crimps. Make sure all of the wires are clean, securely fastened and providing a good ground path. If multiple wires are cased in one eyelet make sure no ground wires have excess wire insulation.

For detailed ground distribution information, refer to [PG-31, "Ground Distribution"](#) .

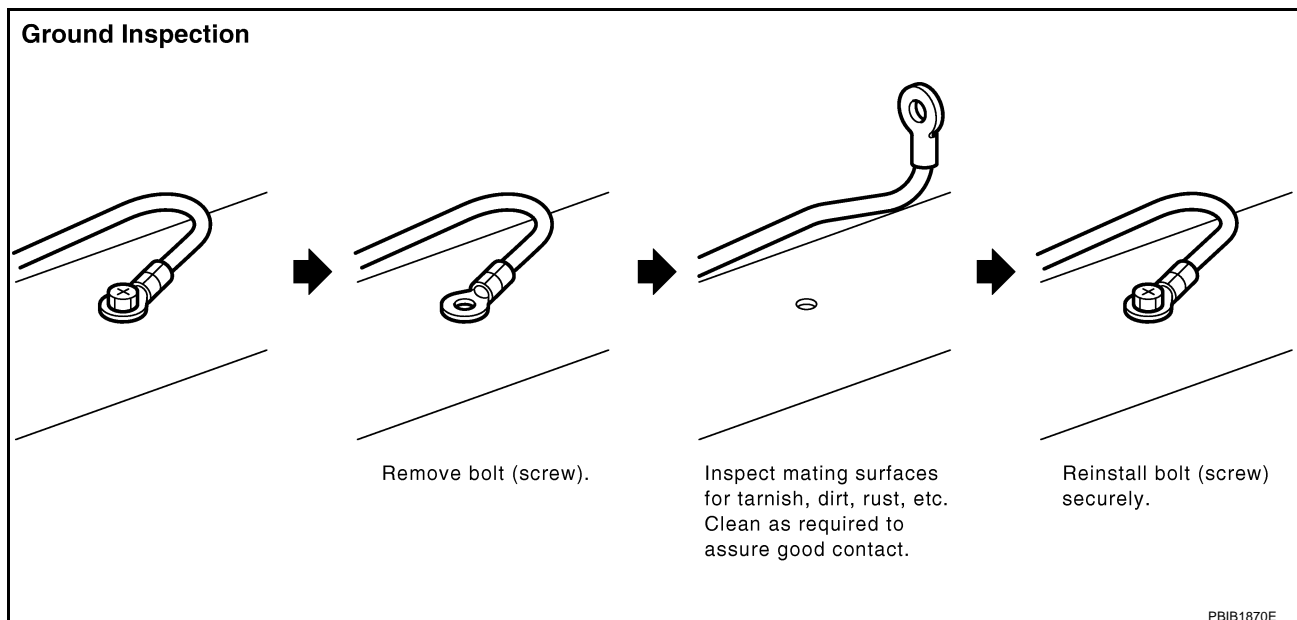

DTC U1000, U1001 CAN COMMUNICATION LINE

PFP:23710

Description

ABS00C0A

CAN (Controller Area Network) is a serial communication line for real time application. It is an on-vehicle multiplex communication line with high data communication speed and excellent error detection ability. Many electronic control units are equipped onto a vehicle, and each control unit shares information and links with other control units during operation (not independent). In CAN communication, control units are connected with 2 communication lines (CAN H line, CAN L line) allowing a high rate of information transmission with less wiring. Each control unit transmits/receives data but selectively reads required data only.

On Board Diagnosis Logic

ABS00C0B

DTC No.	Trouble diagnosis name	DTC detecting condition	Possible cause
U1000*1 1000*1	CAN communication line	<ul style="list-style-type: none"> ● ECM cannot communicate to other control units. ● ECM cannot communicate for more than the specified time. 	<ul style="list-style-type: none"> ● Harness or connectors (CAN communication line is open or shorted)
U1001*2 1001*2			

*1: This self-diagnosis has the one trip detection logic.

*2: The MIL will not light up for this diagnosis.

DTC Confirmation Procedure

ABS00C0C

1. Turn ignition switch ON and wait at least 3 seconds.
2. Select "DATA MONITOR" mode with CONSULT-II.
3. If 1st trip DTC is detected, go to [EC-794, "Diagnostic Procedure"](#).



DTC U1000, U1001 CAN COMMUNICATION LINE

[VK45DE]

Wiring Diagram

ABS00C0D

EC-CAN-01

-  : DETECTABLE LINE FOR DTC
-  : NON-DETECTABLE LINE FOR DTC
-  : DATA LINE

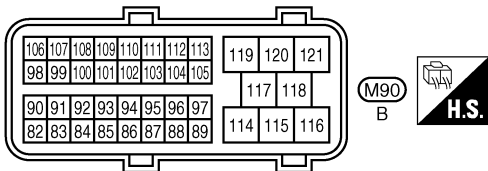
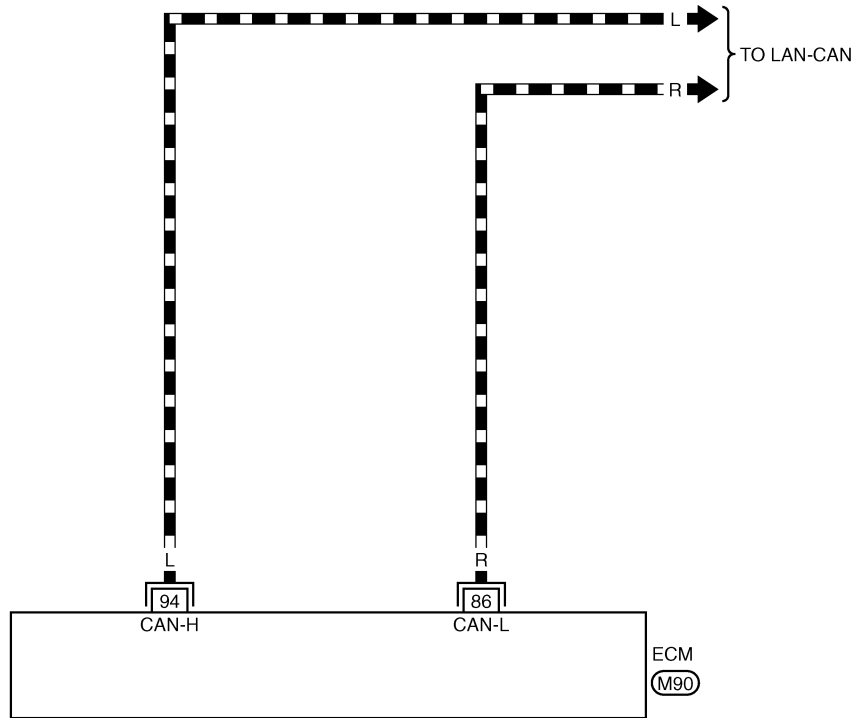

TBWM0218E

Diagnostic Procedure

ABS00C0E

Go to [LAN-4, "Precautions When Using CONSULT-II"](#) .

DTC P0011, P0021 IVT CONTROL

PFP:23796

Description
SYSTEM DESCRIPTION

ABS00C0F

Sensor	Input signal to ECM function	ECM	Actuator
Crankshaft position sensor (POS) Camshaft position sensor (PHASE)	Engine speed	Intake valve timing control	Intake valve timing control solenoid valve
Intake valve timing control position sensor	Intake valve timing signal		
Engine coolant temperature sensor	Engine coolant temperature		
Wheel sensor*	Vehicle speed		

*: This signal is sent to the ECM through CAN communication line

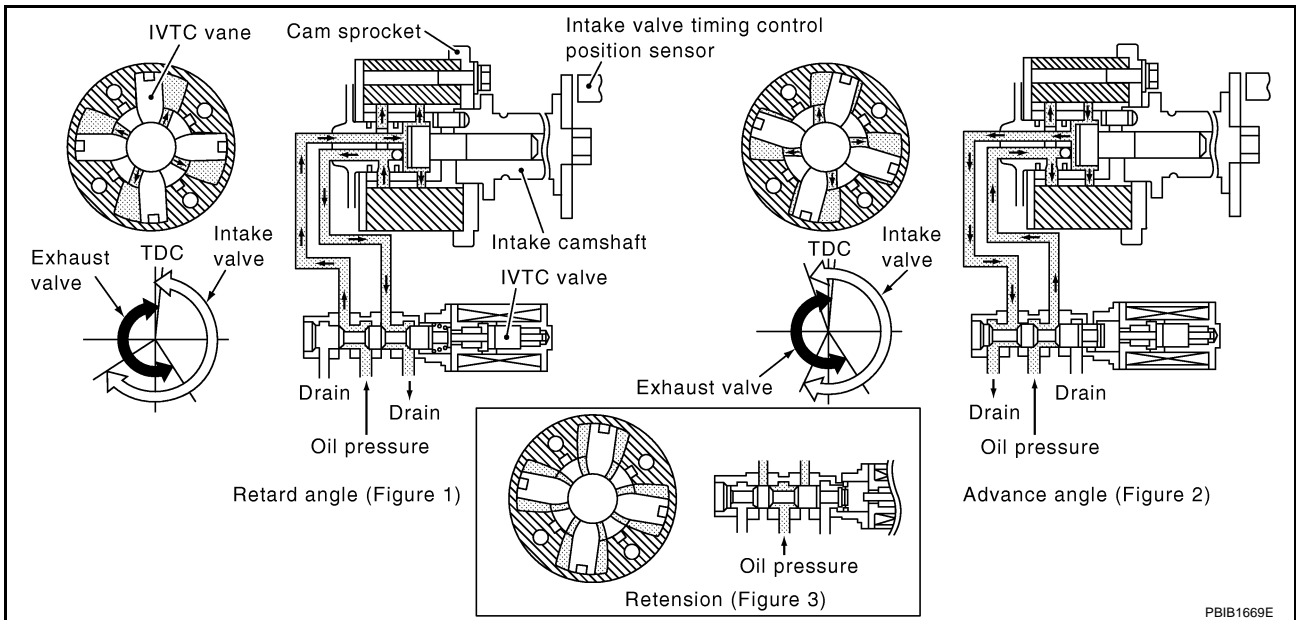

This mechanism hydraulically controls cam phases continuously with the fixed operating angle of the intake valve.

The ECM receives signals such as crankshaft position, camshaft position, engine speed, and engine coolant temperature. Then, the ECM sends ON/OFF pulse duty signals to the intake valve timing (IVT) control solenoid valve depending on driving status. This makes it possible to control the shut/open timing of the intake valve to increase engine torque in low/mid speed range and output in high-speed range.

COMPONENT INSPECTION

Intake Valve Timing Control Solenoid Valve

Intake Valve Timing (IVT) control solenoid valve is activated by ON/OFF pulse duty (ratio) signals from the ECM.

The IVT control solenoid valve changes the oil amount and direction of flow through intake valve timing control unit or stops oil flow.

The longer pulse width advances valve angle.

The shorter pulse width retards valve angle.

When ON and OFF pulse widths become equal, the solenoid valve stops oil pressure flow to fix the intake valve angle at the control position.

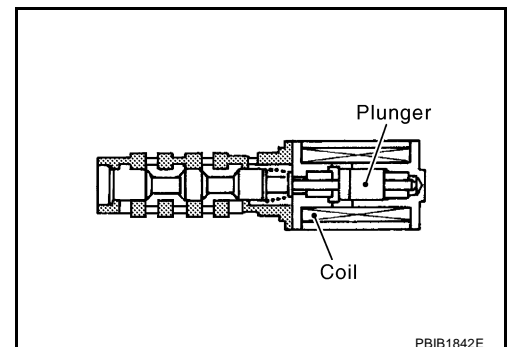

Intake Valve Timing Control Position Sensor

Intake valve timing control position sensors are located in the front of cylinder heads in both bank 1 and bank 2.

This sensor uses a Hall IC.

The cam position is determined by the intake primary cam sprocket concave (in three places). The ECM provides feedback to the intake valve timing control for appropriate target valve open-close timing according to drive conditions based on detected cam position.

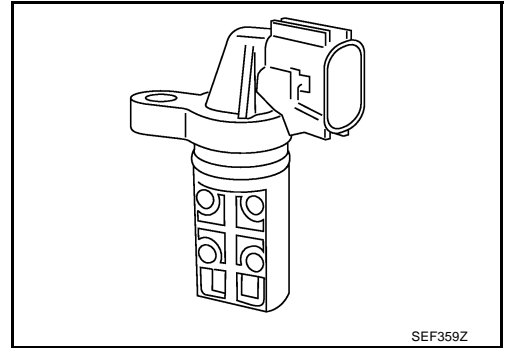

CONSULT-II Reference Value in Data Monitor Mode

ABS00C0G

Specification data are reference values.

MONITOR ITEM	CONDITION	SPECIFICATION
INT/V TIM (B1) INT/V TIM (B2)	<ul style="list-style-type: none"> ● Engine: After warming up ● Air conditioner switch: OFF Idle	-5° - 5°CA
	<ul style="list-style-type: none"> ● Shift lever: N ● No load 2,000 rpm	Approx. 0° - 20°CA
INT/V SOL (B1) INT/V SOL (B2)	<ul style="list-style-type: none"> ● Engine: After warming up ● Air conditioner switch: OFF Idle	0% - 2%
	<ul style="list-style-type: none"> ● Shift lever: N ● No load 2,000 rpm	Approx. 25% - 50%

On Board Diagnosis Logic

ABS00C0H

DTC No.	Trouble diagnosis name	Detecting condition		Possible cause
P0011 0011 (Bank 1)	Intake valve timing control performance	A	The alignment of the intake valve timing control has been misregistered.	<ul style="list-style-type: none"> ● Harness or connectors (Intake valve timing control solenoid valve circuit is open or shorted.) ● Harness or connectors (Intake valve timing control position sensor circuit is open or shorted.) ● Intake valve timing control solenoid valve ● Intake valve timing control position sensor ● Crankshaft position sensor (POS) ● Camshaft position sensor (PHASE) ● Accumulation of debris to the signal pick-up portion of the camshaft
P0021 0021 (Bank 2)		B	There is a gap between angle of target and phase-control angle degree.	

FAIL-SAFE MODE

When the malfunction is detected, the ECM enters fail-safe mode.

Detected items	Engine operating condition in fail-safe mode
Intake valve timing control	The signal is not energized to the solenoid valve and the valve control does not function

DTC Confirmation Procedure

CAUTION:

Always drive at a safe speed.

NOTE:

- If DTC P0011 or P0021 is displayed with DTC P1111, P1136, P1140 or P1145, first perform the trouble diagnosis for [EC-1070](#) or [EC-1095](#) .
- If DTC Confirmation Procedure has been previously conducted, always turn ignition switch OFF and wait at least 10 seconds before conducting the next test.

TESTING CONDITION:

Before performing the following procedure, confirm that battery voltage is between 10V and 16V at idle.

PROCEDURE FOR MALFUNCTION A

 **With CONSULT-II**

1. Turn ignition switch ON.
2. Select "DATA MONITOR" mode with CONSULT-II.
3. Maintain the following conditions for at least 10 consecutive seconds.

ENG SPEED	More than 2,000 rpm (A constant rotation is maintained.)
COOLAN TEMP/S	More than 70°C (158°F)
Selector lever	1st or 2nd position
Driving location uphill	Driving vehicle uphill (Increased engine load will help maintain the driving conditions required for this test.)

DATA MONITOR	
MONITOR	NO DTC
ENG SPEED	XXX rpm
B/FUEL SCHDL	XXX msec
COOLAN TEMP/S	XXX °C
VHCL SPEED SE	XXX km/h
INT/V TIM (B1)	XXX °CA
INT/V TIM (B2)	XXX °CA
INT/V SOL (B1)	XXX %
INT/V SOL (B2)	XXX %

SEF353Z

4. Maintain the following conditions for at least 20 consecutive seconds.

ENG SPEED	Idle
COOLAN TEMP/S	More than 70°C (158°F)
Selector lever	P or N position

5. If the 1st trip DTC is detected, go to [EC-801, "Diagnostic Procedure"](#) .

 **With GST**

Follow the procedure "With CONSULT-II" above.

PROCEDURE FOR MALFUNCTION B

 **With CONSULT-II**

1. Turn ignition switch ON.
2. Select "DATA MONITOR" mode with CONSULT-II.
3. Maintain the following conditions for at least 10 consecutive seconds.

ENG SPEED	2,000 - 3,000 rpm (A constant rotation is maintained.)
COOLAN TEMP/S	80 - 90°C (176 - 194°F)
Selector lever	1st or 2nd position
Driving location uphill	Driving vehicle uphill (Increased engine load will help maintain the driving conditions required for this test.)

DATA MONITOR	
MONITOR	NO DTC
ENG SPEED	XXX rpm
B/FUEL SCHDL	XXX msec
COOLAN TEMP/S	XXX °C
VHCL SPEED SE	XXX km/h
INT/V TIM (B1)	XXX °CA
INT/V TIM (B2)	XXX °CA
INT/V SOL (B1)	XXX %
INT/V SOL (B2)	XXX %

SEF353Z

4. If the 1st trip DTC is detected, go to [EC-801, "Diagnostic Procedure"](#) .

 **With GST**

Follow the procedure "With CONSULT-II" above.

DTC P0011, P0021 IVT CONTROL

[VK45DE]

ABS00C0J

Wiring Diagram BANK 1

EC-IVTB1-01

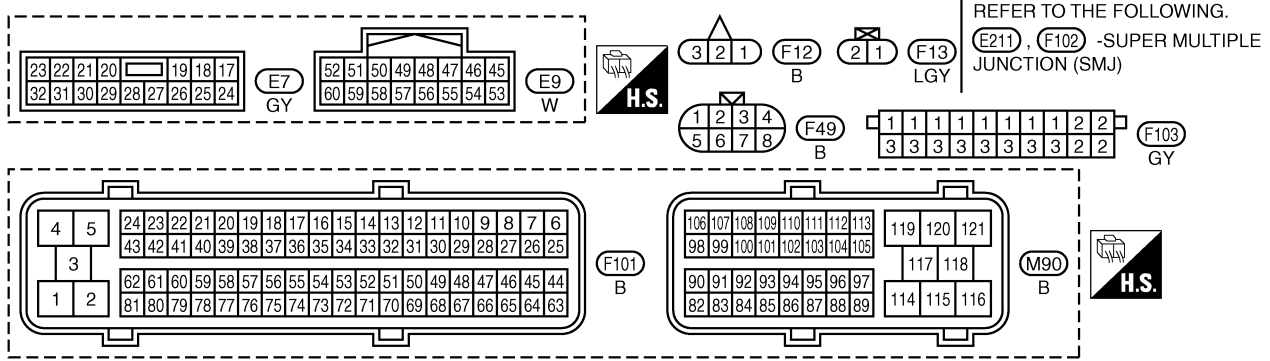
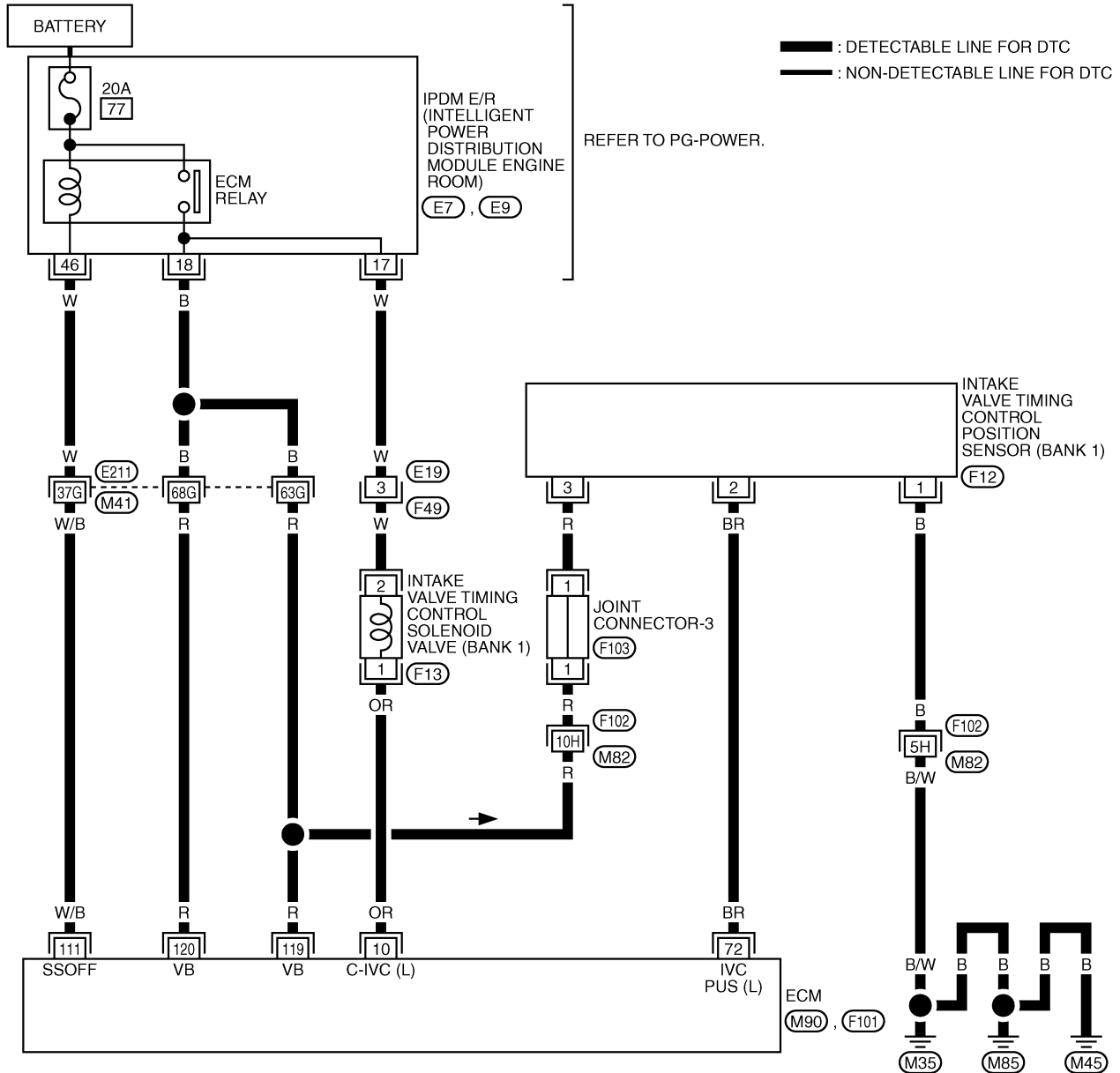

TBWM0277E

DTC P0011, P0021 IVT CONTROL

[VK45DE]

Specification data are reference values and are measured between each terminal and ground.
Pulse signal is measured by CONSULT-II.

CAUTION:

Do not use ECM ground terminals when measuring input/output voltage. Doing so may result in damage to the ECM's transistor. Use a ground other than ECM terminals, such as the ground.

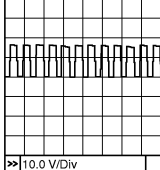
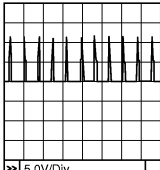
TER-MINAL NO.	WIRE COLOR	ITEM	CONDITION	DATA (DC Voltage)
10	OR	Intake valve timing control solenoid valve (bank 1)	[Engine is running] ● Warm-up condition ● Idle speed	BATTERY VOLTAGE (11 - 14V)
			[Engine is running] ● Warm-up condition ● Engine speed is 2,000 rpm	7 - 12V★  PBIB1790E
72	BR	Intake valve timing control position sensor (bank 1)	[Engine is running] ● Warm-up condition ● Idle speed	0 - 1.0V
			[Engine is running] ● Engine speed is 2,000 rpm	0 - 1.0V★  PBIB2046E

★: Average voltage for pulse signal (Actual pulse signal can be confirmed by oscilloscope.)

A
EC
C
D
E
F
G
H
I
J
K
L
M

BANK 2

EC-IVTB2-01

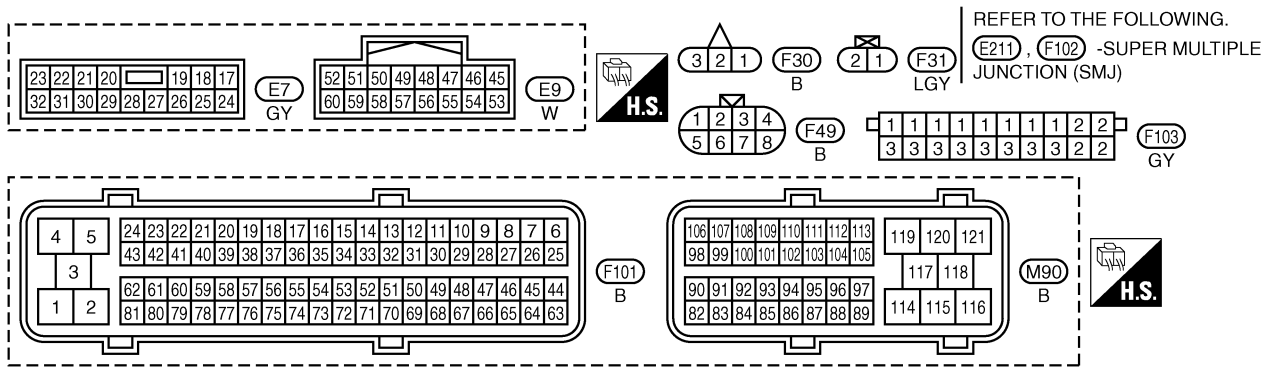
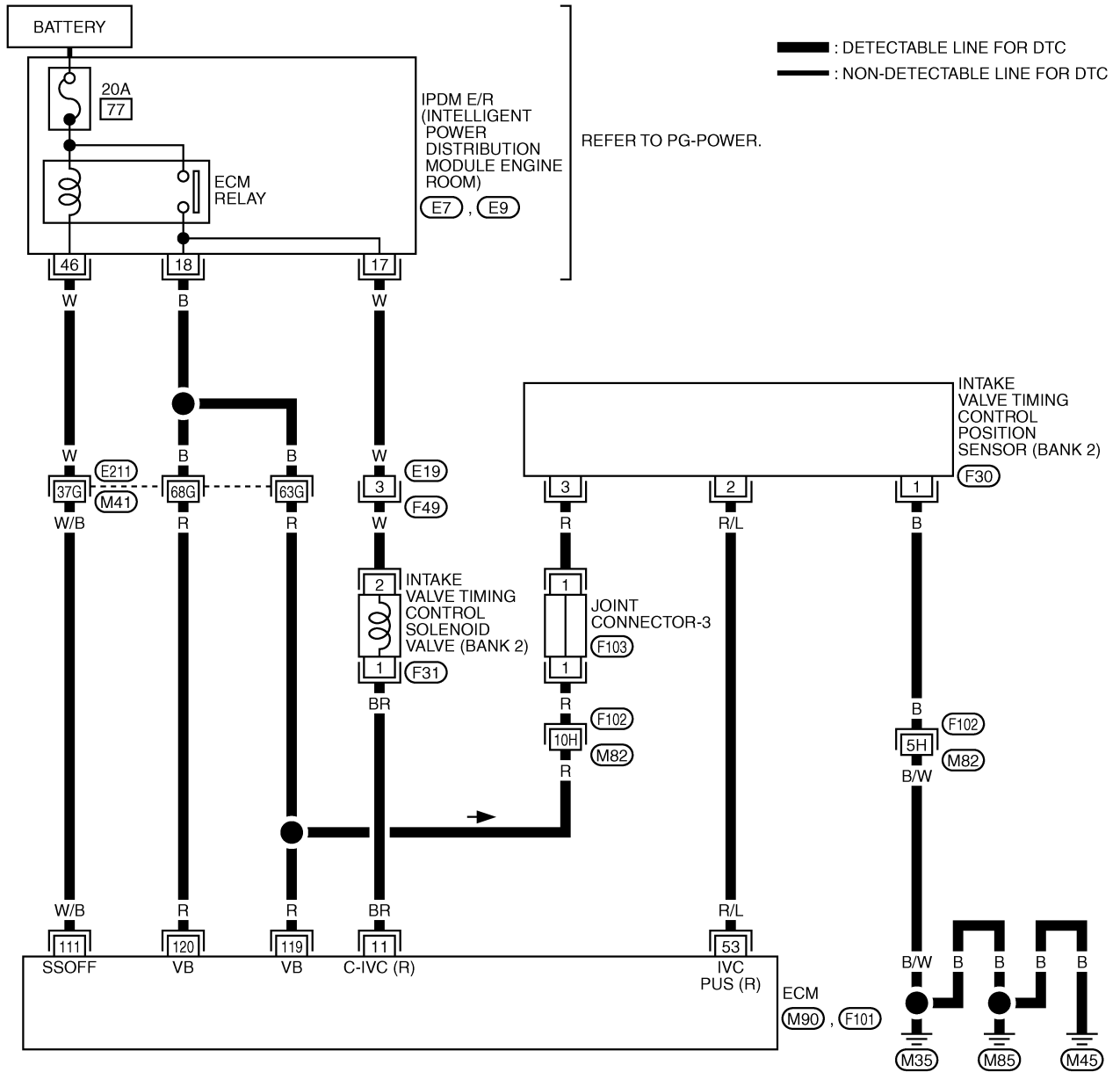

TBWM0278E

DTC P0011, P0021 IVT CONTROL

[VK45DE]

Specification data are reference values and are measured between each terminal and ground.
Pulse signal is measured by CONSULT-II.

CAUTION:

Do not use ECM ground terminals when measuring input/output voltage. Doing so may result in damage to the ECM's transistor. Use a ground other than ECM terminals, such as the ground.

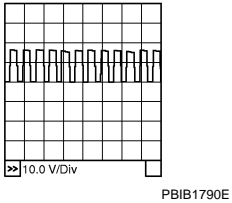
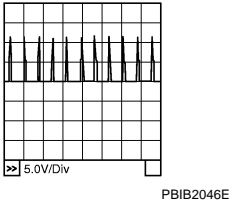
TER-MINAL NO.	WIRE COLOR	ITEM	CONDITION	DATA (DC Voltage)
11	BR	Intake valve timing control solenoid valve (bank 2)	[Engine is running] ● Warm-up condition ● Idle speed	BATTERY VOLTAGE (11 - 14V)
			[Engine is running] ● Warm-up condition ● Engine speed is 2,000 rpm	7 - 12V★ 
53	R/L	Intake valve timing control position sensor (bank 2)	[Engine is running] ● Warm-up condition ● Idle speed	0 - 1.0V
			[Engine is running] ● Engine speed is 2,000 rpm	0 - 1.0V★ 

★: Average voltage for pulse signal (Actual pulse signal can be confirmed by oscilloscope.)

Diagnostic Procedure

ABS00C0K

1. CHECK GROUND CONNECTIONS

1. Turn ignition switch OFF.
2. Loosen and retighten three ground screws on the body.
Refer to [EC-791, "Ground Inspection"](#) .

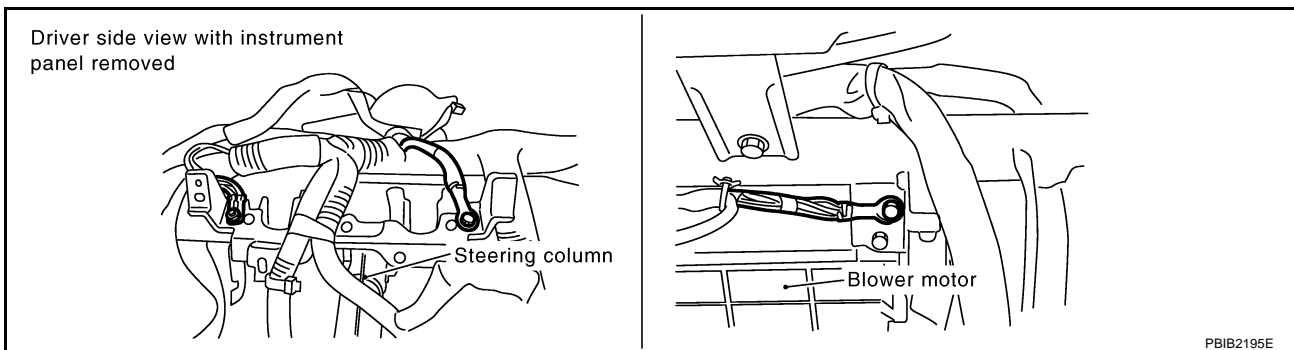

OK or NG

- OK >> GO TO 2.
- NG >> Repair or replace ground connections.

2. CHECK INTAKE VALVE TIMING CONTROL POSITION SENSOR POWER SUPPLY CIRCUIT

1. Disconnect intake valve timing control position sensor harness connector.

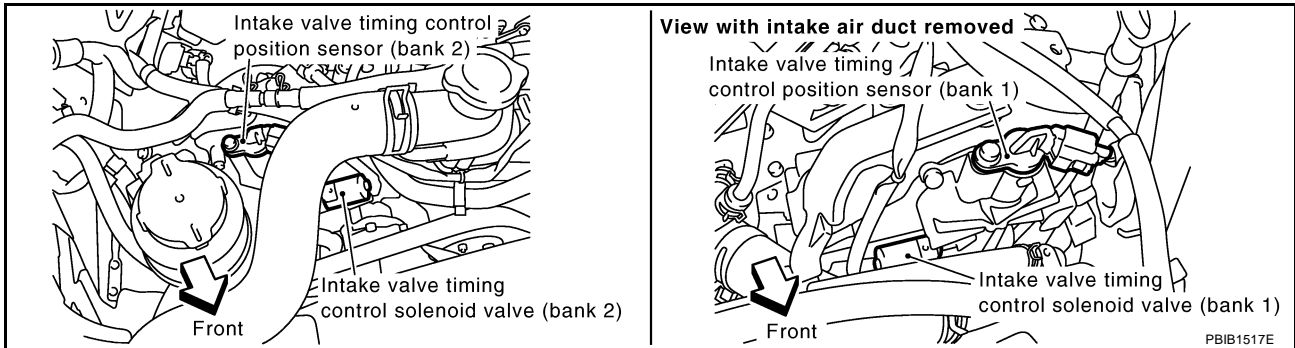

2. Turn ignition switch ON.
3. Check voltage between intake valve timing control position sensor terminal 3 and ground with CONSULT-II or tester.

Voltage: Battery voltage

OK or NG

- OK >> GO TO 4.
- NG >> GO TO 3.

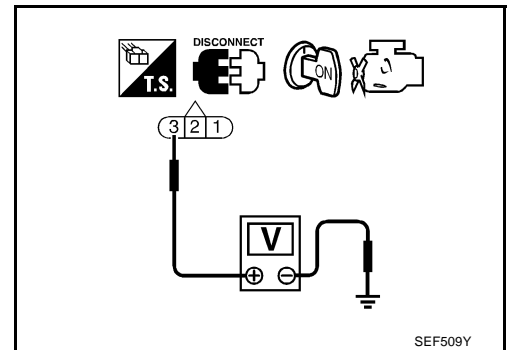

3. DETECT MALFUNCTIONING PART

Check the following.

- Harness connectors E211, M41
- Harness connectors F102, M82
- Joint connector-3
- Harness for open or short between intake valve timing control position sensor and ECM
- Harness for open or short between intake valve timing control position sensor and IPDM E/R

>> Repair open circuit or short to ground or short to power in harness or connectors.

4. CHECK INTAKE VALVE TIMING CONTROL POSITION SENSOR GROUND CIRCUIT FOR OPEN AND SHORT

1. Turn ignition switch OFF.
2. Check harness continuity between intake valve timing control position sensor terminal 1 and ground. Refer to Wiring Diagram.

Continuity should exist.

3. Also check harness for short to power.

OK or NG

- OK >> GO TO 6.
- NG >> GO TO 5.

5. DETECT MALFUNCTIONING PART

Check the following.

- Harness connectors F102, M82
- Harness for open or short between intake valve timing control position sensor and ground

>> Repair open circuit or short to power in harness or connectors.

6. CHECK INTAKE VALVE TIMING CONTROL POSITION SENSOR INPUT SIGNAL CIRCUIT FOR OPEN AND SHORT

1. Disconnect ECM harness connector.
2. Check harness continuity between ECM terminal 72 and intake valve timing control position sensor (bank 1) terminal 2 or ECM terminal 53 and intake valve timing control position sensor (bank 2) terminal 2. Refer to Wiring Diagram.

Continuity should exist.

3. Also check harness for short to ground and short to power.

OK or NG

OK >> GO TO 7.

NG >> Repair open circuit or short to ground or short to power in harness or connectors.

7. CHECK INTAKE VALVE TIMING CONTROL POSITION SENSOR

Refer to [EC-805, "Component Inspection"](#).

OK or NG

OK >> GO TO 8.

NG >> Replace intake valve timing control position sensor.

8. CHECK INTAKE VALVE TIMING CONTROL SOLENOID VALVE POWER SUPPLY CIRCUIT

1. Disconnect intake valve timing control solenoid valve harness connector.

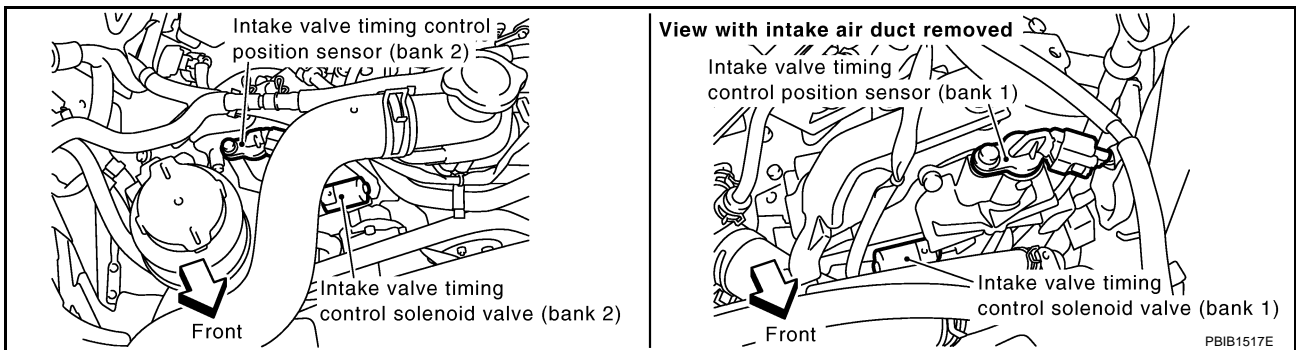

2. Turn ignition switch ON.
3. Check voltage between intake valve timing control solenoid valve terminal 2 and ground with CONSULT-II or tester.

Voltage: Battery voltage

OK or NG

OK >> GO TO 10.

NG >> GO TO 9.

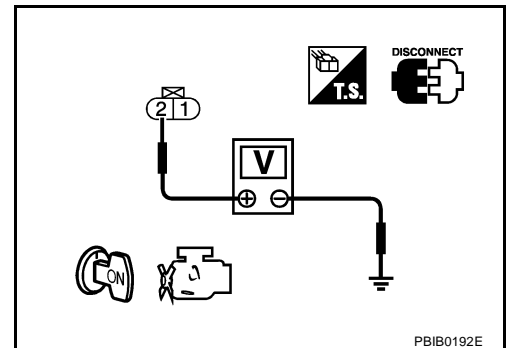

9. DETECT MALFUNCTIONING PART

Check the following.

- Harness connectors E19, F49
- Harness for open or short between intake valve timing control solenoid valve and IPDM E/R

>> Repair open circuit or short to ground or short to power in harness or connectors.

10. CHECK INTAKE VALVE TIMING CONTROL SOLENOID VALVE OUTPUT SIGNAL CIRCUIT FOR OPEN AND SHORT

1. Check harness continuity between ECM terminal 10 and intake valve timing control solenoid valve (bank 1) terminal 1 or ECM terminal 11 and intake valve timing control solenoid valve (bank 2) terminal 1. Refer to Wiring Diagram.

Continuity should exist.

2. Also check harness for short to ground and short to power.

OK or NG

OK >> GO TO 11.

NG >> Repair open circuit or short to ground or short to power in harness or connectors.

11. CHECK INTAKE VALVE TIMING CONTROL SOLENOID VALVE

Refer to [EC-805, "Component Inspection"](#) .

OK or NG

OK >> GO TO 12.

NG >> Replace intake valve timing control solenoid valve.

12. CHECK CRANKSHAFT POSITION SENSOR (POS)

Refer to [EC-964, "Component Inspection"](#) .

OK or NG

OK >> GO TO 13.

NG >> Replace crankshaft position sensor (POS).

13. CHECK CAMSHAFT POSITION SENSOR (PHASE)

Refer to [EC-970, "Component Inspection"](#) .

OK or NG

OK >> GO TO 14.

NG >> Replace camshaft position sensor (PHASE).

14. CHECK CAMSHAFT

Check accumulation of debris to the signal pick-up portion of the camshaft. Refer to [EM-208, "CAMSHAFT"](#) .

OK or NG

OK >> GO TO 15.

NG >> Remove debris and clean the signal pick-up cutout of camshaft.

15. CHECK INTERMITTENT INCIDENT

Refer to [EC-784, "TROUBLE DIAGNOSIS FOR INTERMITTENT INCIDENT"](#) .

For wiring diagram, refer to [EC-961](#) for CKP sensor (POS), and [EC-967](#) for CMP sensor (PHASE).

>> **INSPECTION END**

Component Inspection

INTAKE VALVE TIMING CONTROL POSITION SENSOR

1. Disconnect intake valve timing control position sensor harness connector.
2. Loosen the fixing bolt of the sensor.
3. Remove the sensor.
4. Visually check the sensor for chipping.

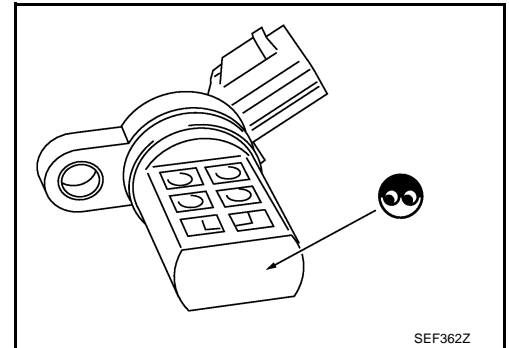

5. Check resistance as shown below.

Terminal No. (Polarity)	Resistance Ω [at 25°C (77°F)]
3 (+) - 1 (-)	Except 0 or ∞
2 (+) - 1 (-)	
3 (+) - 2 (-)	

6. If NG, replace intake valve timing control position sensor.

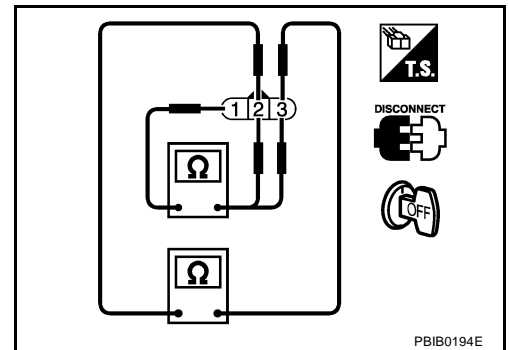

INTAKE VALVE TIMING CONTROL SOLENOID VALVE

1. Disconnect intake valve timing control solenoid valve harness connector.
2. Check resistance between intake valve timing control solenoid valve terminals as follows.

Terminals	Resistance
1 and 2	7.0 - 7.5 Ω at 20°C (68°F)
1 or 2 and ground	$\infty\Omega$ (Continuity should not exist)

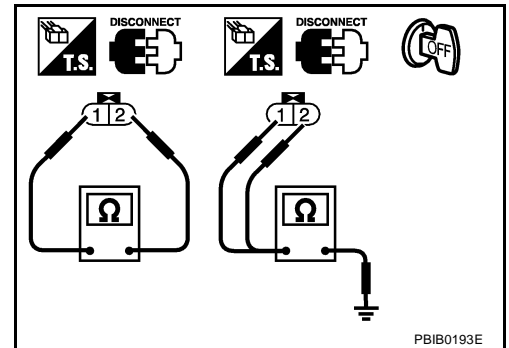

Removal and Installation

INTAKE VALVE TIMING CONTROL POSITION SENSOR

Refer to [EM-196, "TIMING CHAIN"](#) .

INTAKE VALVE TIMING CONTROL SOLENOID VALVE

Refer to [EM-196, "TIMING CHAIN"](#) .

DTC P0031, P0032, P0051, P0052 HO2S1 HEATER

[VK45DE]

DTC P0031, P0032, P0051, P0052 HO2S1 HEATER

PFP:22690

Description SYSTEM DESCRIPTION

ABS00C0N

Sensor	Input signal to ECM	ECM function	Actuator
Camshaft position sensor (PHASE) Crankshaft position sensor (POS)	Engine speed	Heated oxygen sensor 1 heater control	Heated oxygen sensor 1 heater
Engine coolant temperature sensor	Engine coolant temperature		

The ECM performs ON/OFF control of the heated oxygen sensor 1 heater corresponding to the engine speed and engine coolant temperature. The duty percent varies with engine coolant temperature when engine is started.

OPERATION

Engine speed rpm	Heated oxygen sensor 1 heater
Above 3,000	OFF
Below 3,000 after warming up	ON

CONSULT-II Reference Value in Data Monitor Mode

ABS00C00

Specification data are reference values.

MONITOR ITEM	CONDITION	SPECIFICATION
HO2S1 HTR (B1) HO2S1 HTR (B2)	<ul style="list-style-type: none"> ● Engine: After warming up ● Engine speed: Below 3,000 rpm 	ON
	<ul style="list-style-type: none"> ● Engine speed: Above 3,000 rpm 	OFF

On Board Diagnosis Logic

ABS00C0P

DTC No.	Trouble diagnosis name	DTC detecting condition	Possible cause
P0031 0031 (Bank 1)	Heated oxygen sensor 1 heater control circuit low	The current amperage in the heated oxygen sensor 1 heater circuit is out of the normal range. (An excessively low voltage signal is sent to ECM through the heated oxygen sensor 1 heater.)	<ul style="list-style-type: none"> ● Harness or connectors (The heated oxygen sensor 1 heater circuit is open or shorted.) ● Heater oxygen sensor 1 heater
P0051 0051 (Bank 2)			
P0032 0032 (Bank 1)	Heated oxygen sensor 1 heater control circuit high	The current amperage in the heated oxygen sensor 1 heater circuit is out of the normal range. (An excessively high voltage signal is sent to ECM through the heated oxygen sensor 1 heater.)	<ul style="list-style-type: none"> ● Harness or connectors (The heated oxygen sensor 1 heater circuit is shorted.) ● Heater oxygen sensor 1 heater
P0052 0052 (Bank 2)			

DTC Confirmation Procedure**NOTE:**

If DTC Confirmation Procedure has been previously conducted, always turn ignition switch OFF and wait at least 10 seconds before conducting the next test.

TESTING CONDITION:

Before performing the following procedure, confirm that battery voltage is between 10.5V and 16V at idle.

 **WITH CONSULT-II**

1. Start engine and warm it up to normal operating temperature.
2. Turn ignition switch OFF and wait at least 10 seconds.
3. Turn ignition switch ON and select "DATA MONITOR" mode with CONSULT-II.
4. Start engine and run it for at least 6 seconds at idle speed.
5. If 1st trip DTC is detected, go to [EC-811, "Diagnostic Procedure"](#)

DATA MONITOR	
MONITOR	NO DTC
ENG SPEED	XXX rpm
COOLAN TEMP/S	XXX °C

SEF174Y

 **WITH GST**

Follow the procedure "WITH CONSULT-II" above.

A

EC

C

D

E

F

G

H

I

J

K

L

M

DTC P0031, P0032, P0051, P0052 HO2S1 HEATER

[VK45DE]

ABS00COR

Wiring Diagram BANK 1

EC-O2H1B1-01

— : DETECTABLE LINE FOR DTC
 — : NON-DETECTABLE LINE FOR DTC

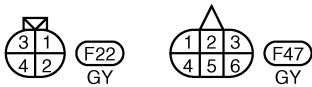
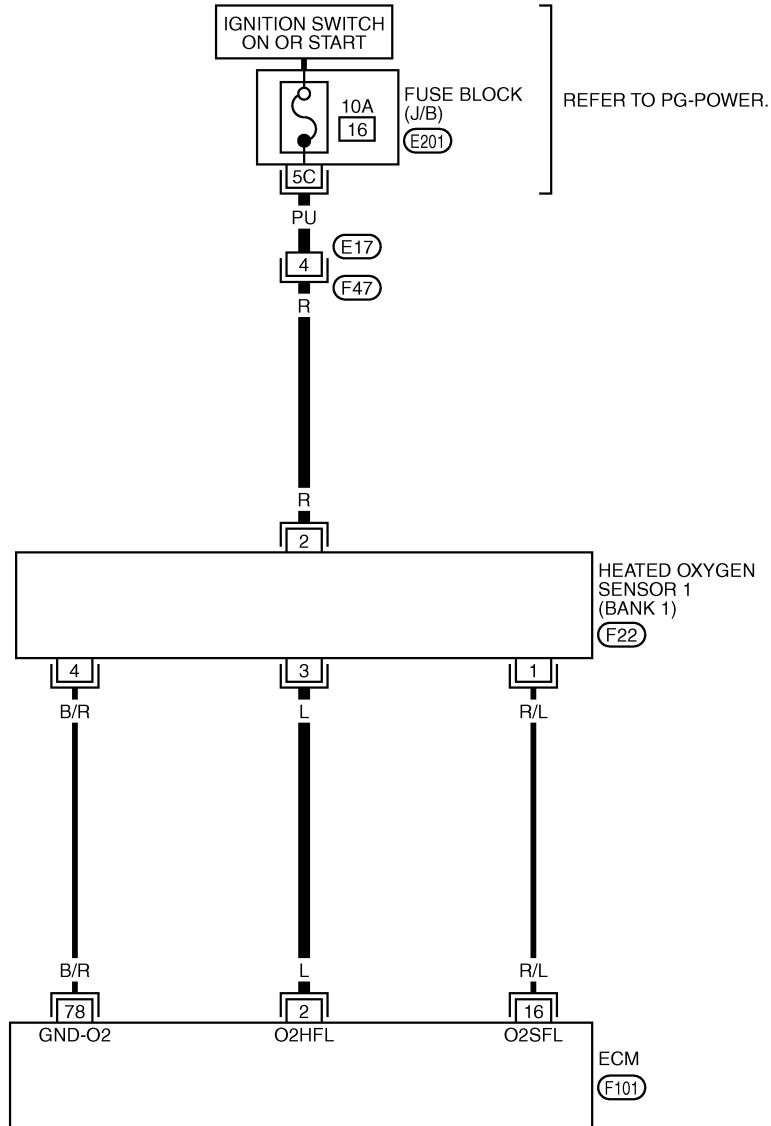

REFER TO THE FOLLOWING.
 (E201) - FUSE BLOCK-JUNCTION BOX (J/B)

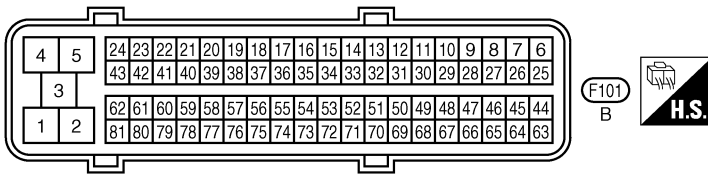

TBWM0221E

DTC P0031, P0032, P0051, P0052 HO2S1 HEATER

[VK45DE]

Specification data are reference values and are measured between each terminal and ground.
Pulse signal is measured by CONSULT-II.

CAUTION:

Do not use ECM ground terminals when measuring input/output voltage. Doing so may result in damage to the ECM's transistor. Use a ground other than ECM terminals, such as the ground.

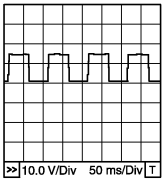
TER-MINAL NO.	WIRE COLOR	ITEM	CONDITION	DATA (DC Voltage)
2	L	Heated oxygen sensor 1 heater (bank 1)	<p>[Engine is running]</p> <ul style="list-style-type: none"> ● Warm-up condition ● Engine speed is below 3,000 rpm 	<p>Approximately 7V★</p> 
			<p>[Engine is running]</p> <ul style="list-style-type: none"> ● Engine speed is above 3,000 rpm 	<p>BATTERY VOLTAGE (11 - 14V)</p>

★: Average voltage for pulse signal (Actual pulse signal can be confirmed by oscilloscope.)

A
EC
C
D
E
F
G
H
I
J
K
L
M

DTC P0031, P0032, P0051, P0052 HO2S1 HEATER

[VK45DE]

BANK 2

EC-O2H1B2-01

— : DETECTABLE LINE FOR DTC
 — : NON-DETECTABLE LINE FOR DTC

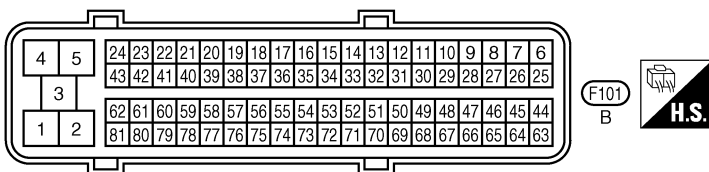
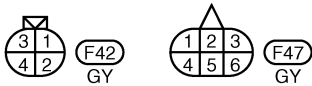
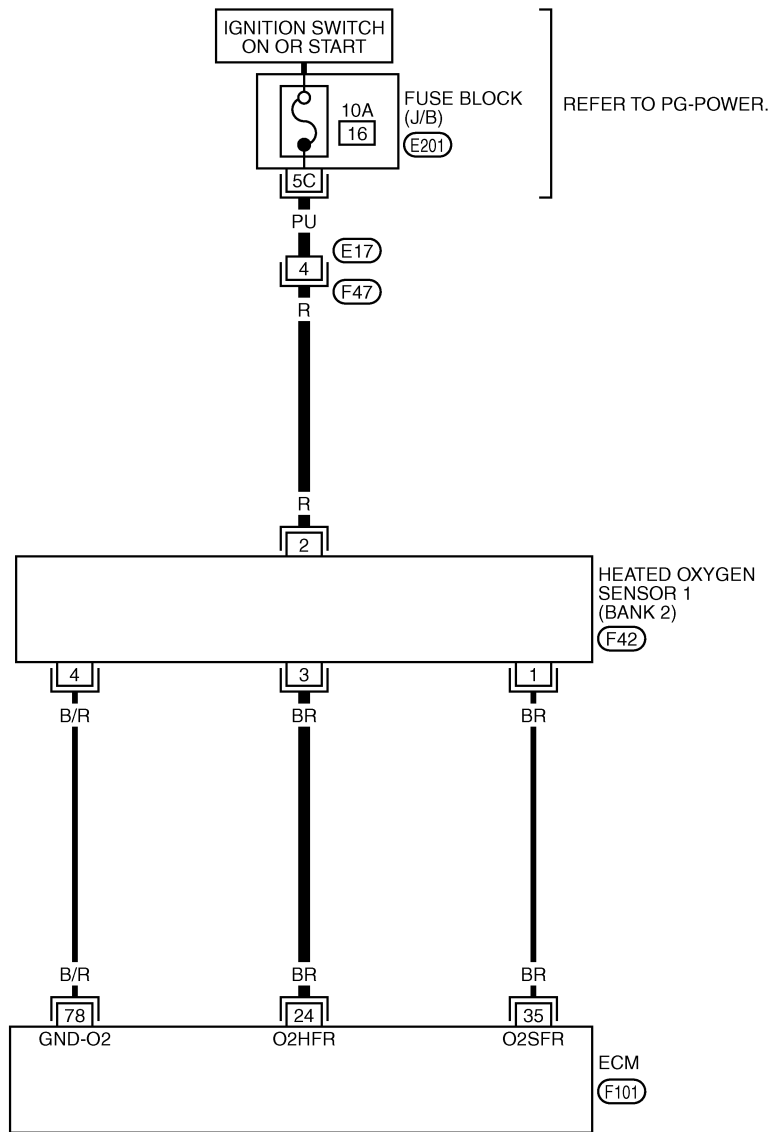

REFER TO THE FOLLOWING.
 (E201) - FUSE BLOCK-JUNCTION BOX (J/B)

TBWM0222E

DTC P0031, P0032, P0051, P0052 HO2S1 HEATER

[VK45DE]

Specification data are reference values and are measured between each terminal and ground.
Pulse signal is measured by CONSULT-II.

CAUTION:

Do not use ECM ground terminals when measuring input/output voltage. Doing so may result in damage to the ECM's transistor. Use a ground other than ECM terminals, such as the ground.

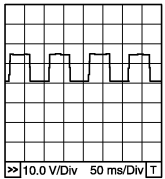
TER-MINAL NO.	WIRE COLOR	ITEM	CONDITION	DATA (DC Voltage)
24	BR	Heated oxygen sensor 1 heater (bank 2)	[Engine is running] <ul style="list-style-type: none"> ● Warm-up condition ● Engine speed is below 3,000 rpm 	Approximately 7V★  <small>PBIB0519E</small>
			[Engine is running] <ul style="list-style-type: none"> ● Engine speed is above 3,000 rpm 	BATTERY VOLTAGE (11 - 14V)

★: Average voltage for pulse signal (Actual pulse signal can be confirmed by oscilloscope.)

Diagnostic Procedure

ABS00C0S

1. CHECK GROUND CONNECTIONS

1. Turn ignition switch OFF.
2. Loosen and retighten three ground screws on the body.
Refer to [EC-791, "Ground Inspection"](#).

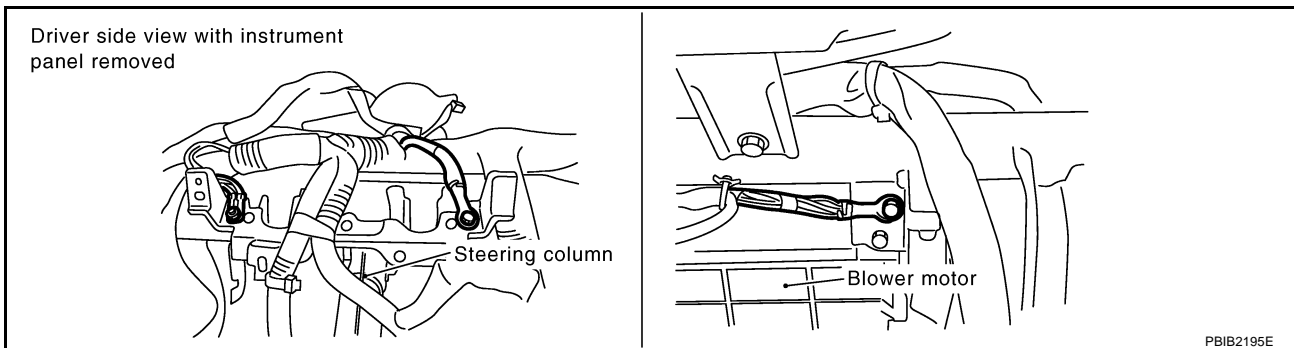

OK or NG

- OK >> GO TO 2.
- NG >> Repair or replace ground connections.

2. CHECK HO2S1 POWER SUPPLY CIRCUIT

1. Disconnect heated oxygen sensor 1 harness connector.

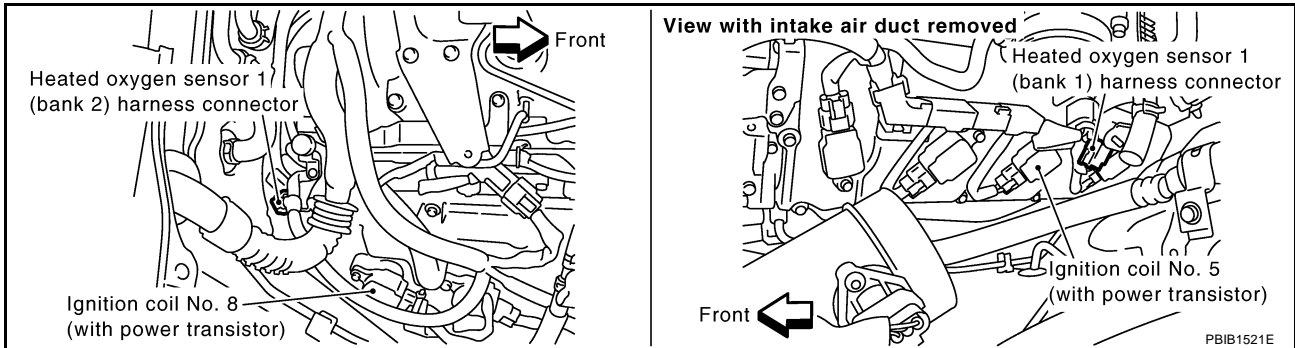

2. Turn ignition switch ON.
3. Check voltage between HO2S1 terminal 2 and ground with CONSULT-II or tester.

Voltage: Battery voltage

OK or NG

- OK >> GO TO 4.
- NG >> GO TO 3.

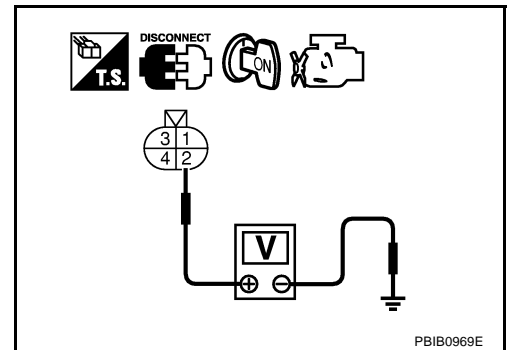

3. DETECT MALFUNCTIONING PART

Check the following.

- Harness connectors E17, F47
- Fuse block (J/B) connector E201
- 10A fuse
- Harness for open or short between heated oxygen sensor 1 and fuse

>> Repair open circuit or short to ground or short to power in harness or connectors.

4. CHECK HO2S1 OUTPUT SIGNAL CIRCUIT FOR OPEN AND SHORT

1. Turn ignition switch OFF.
2. Disconnect ECM harness connector.
3. Check harness continuity between ECM terminal and HO2S1 terminal as follows. Refer to Wiring Diagram.

DTC	Terminals		Bank
	ECM	Sensor	
P0031, P0032	2	3	1
P0051, P0052	24	3	2

Continuity should exist.

4. Also check harness for short to ground and short to power.

OK or NG

- OK >> GO TO 5.
- NG >> Repair open circuit or short to ground or short to power in harness or connectors.

5. CHECK HEATED OXYGEN SENSOR 1 HEATER

Refer to [EC-813, "Component Inspection"](#) .

OK or NG

- OK >> GO TO 6.
- NG >> Replace malfunctioning heated oxygen sensor 1.

6. CHECK INTERMITTENT INCIDENT

Refer to [EC-784, "TROUBLE DIAGNOSIS FOR INTERMITTENT INCIDENT"](#) .

>> INSPECTION END

Component Inspection
HEATED OXYGEN SENSOR 1 HEATER

ABS00C0T

1. Check resistance between HO2S1 terminals as follows.

Terminal No.	Resistance
2 and 3	3.3 - 4.0 Ω at 25°C (77°F)
1 and 2, 3, 4	∞ Ω
4 and 1, 2, 3	(Continuity should not exist)

2. If NG, replace heated oxygen sensor 1.

CAUTION:

- Discard any heated oxygen sensor which has been dropped from a height of more than 0.5 m (19.7 in) onto a hard surface such as a concrete floor; use a new one.
- Before installing new oxygen sensor, clean exhaust system threads using Oxygen Sensor Thread Cleaner tool J-43897-18 or J-43897-12 and approved anti-seize lubricant.

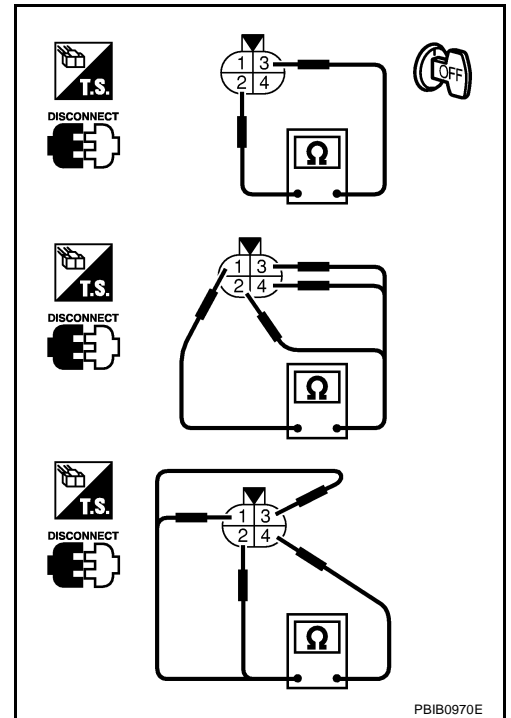

PBIB0970E

Removal and Installation
HEATED OXYGEN SENSOR 1

ABS00C0U

Refer to [EM-178, "EXHAUST MANIFOLD AND THREE WAY CATALYST"](#) .

DTC P0037, P0038, P0057, P0058 HO2S2 HEATER

[VK45DE]

DTC P0037, P0038, P0057, P0058 HO2S2 HEATER

PFP:226A0

Description SYSTEM DESCRIPTION

ABS00C0V

Sensor	Input signal to ECM	ECM function	Actuator
Camshaft position sensor (PHASE) Crankshaft position sensor (POS)	Engine speed	Heated oxygen sensor 2 heater control	Heated oxygen sensor 2 heater
Engine coolant temperature sensor	Engine coolant temperature		
Mass air flow sensor	Amount of intake air		

The ECM performs ON/OFF control of the heated oxygen sensor 2 heater corresponding to the engine speed, amount of intake air and engine coolant temperature.

OPERATION

Engine speed rpm	Heated oxygen sensor 2 heater
Above 3,600	OFF
Below 3,600 rpm after the following conditions are met. <ul style="list-style-type: none"> ● Engine: After warming up ● Keeping the engine speed between 3,500 and 4,000 rpm for 1 minute and at idle for 1 minute under no load 	ON

CONSULT-II Reference Value in Data Monitor Mode

ABS00C0W

Specification data are reference values.

MONITOR ITEM	CONDITION	SPECIFICATION
HO2S2 HTR (B1) HO2S2 HTR (B2)	<ul style="list-style-type: none"> ● Engine speed is below 3,600 rpm after the following conditions are met. <ul style="list-style-type: none"> – Engine: After warming up – Keeping the engine speed between 3,500 and 4,000 rpm for 1 minute and at idle for 1 minute under no load ● Engine speed: Above 3,600 rpm 	ON
	<ul style="list-style-type: none"> ● Engine speed: Above 3,600 rpm 	OFF

On Board Diagnosis Logic

ABS00C0X

DTC No.	Trouble diagnosis name	DTC detecting condition	Possible cause
P0037 0037 (Bank 1)	Heated oxygen sensor 2 heater control circuit low	The current amperage in the heated oxygen sensor 2 heater circuit is out of the normal range. (An excessively low voltage signal is sent to ECM through the heated oxygen sensor 2 heater.)	<ul style="list-style-type: none"> ● Harness or connectors (The heated oxygen sensor 2 heater circuit is open or shorted.) ● Heater oxygen sensor 2 heater
P0057 0057 (Bank 2)			
P0038 0038 (Bank 1)	Heated oxygen sensor 2 heater control circuit high	The current amperage in the heated oxygen sensor 2 heater circuit is out of the normal range. (An excessively high voltage signal is sent to ECM through the heated oxygen sensor 2 heater.)	<ul style="list-style-type: none"> ● Harness or connectors (The heated oxygen sensor 2 heater circuit is shorted.) ● Heater oxygen sensor 2 heater
P0058 0058 (Bank 2)			

DTC Confirmation Procedure

NOTE:

If DTC Confirmation Procedure has been previously conducted, always turn ignition switch OFF and wait at least 10 seconds before conducting the next test.

TESTING CONDITION:

Before performing the following procedure, confirm that battery voltage is between 10.5V and 16V at idle.

WITH CONSULT-II

1. Turn ignition switch ON and select "DATA MONITOR" mode with CONSULT-II.
2. Start engine and warm it up to the normal operating temperature.
3. Turn ignition switch OFF and wait at least 10 seconds.
4. Start the engine and keep the engine speed between 3,500 rpm and 4,000 rpm for at least 1 minute under no load.
5. Let engine idle for 1 minute.
6. If 1st trip DTC is detected, go to [EC-819, "Diagnostic Procedure"](#)

DATA MONITOR	
MONITOR	NO DTC
ENG SPEED	XXX rpm
COOLAN TEMP/S	XXX °C

SEP174Y

WITH GST

Follow the procedure "WITH CONSULT-II" above.

A
EC
C
D
E
F
G
H
I
J
K
L
M

DTC P0037, P0038, P0057, P0058 HO2S2 HEATER

[VK45DE]

ABS00C0Z

Wiring Diagram BANK 1

EC-O2H2B1-01

— : DETECTABLE LINE FOR DTC
— : NON-DETECTABLE LINE FOR DTC

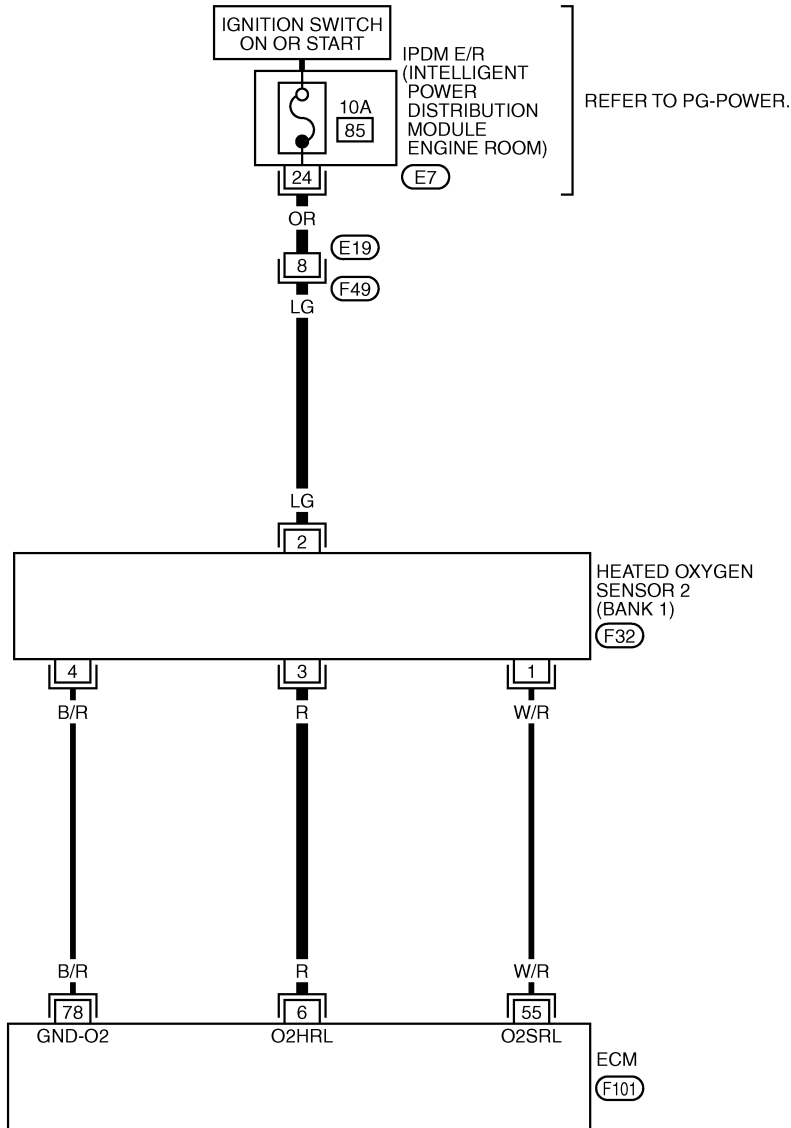

23	22	21	20	19	18	17		
32	31	30	29	28	27	26	25	24

E7
GY



3	1
4	2

F32
GY

1	2	3	4
5	6	7	8

F49
B

4	5	24	23	22	21	20	19	18	17	16	15	14	13	12	11	10	9	8	7	6
	3	43	42	41	40	39	38	37	36	35	34	33	32	31	30	29	28	27	26	25
		62	61	60	59	58	57	56	55	54	53	52	51	50	49	48	47	46	45	44
1	2	81	80	79	78	77	76	75	74	73	72	71	70	69	68	67	66	65	64	63

F101
B



TBWM0223E

DTC P0037, P0038, P0057, P0058 HO2S2 HEATER

[VK45DE]

Specification data are reference values and are measured between each terminal and ground.

CAUTION:

Do not use ECM ground terminals when measuring input/output voltage. Doing so may result in damage to the ECM's transistor. Use a ground other than ECM terminals, such as the ground.

TER-MINAL NO.	WIRE COLOR	ITEM	CONDITION	DATA (DC Voltage)
6	R	Heated oxygen sensor 2 heater (bank 1)	[Engine is running] <ul style="list-style-type: none"> ● Engine speed is below 3,600 rpm after the following conditions are met <ul style="list-style-type: none"> - Engine: after warming up - Keeping the engine speed between 3,500 and 4,000 rpm for 1 minute and at idle for 1 minute under no load 	0 - 1.0V
			[Ignition switch: ON] <ul style="list-style-type: none"> ● Engine stopped [Engine is running] <ul style="list-style-type: none"> ● Engine speed is above 3,600 rpm 	BATTERY VOLTAGE (11 - 14V)

A
EC
C
D
E
F
G
H
I
J
K
L
M

DTC P0037, P0038, P0057, P0058 HO2S2 HEATER

[VK45DE]

BANK 2

EC-O2H2B2-01

— : DETECTABLE LINE FOR DTC
 — : NON-DETECTABLE LINE FOR DTC

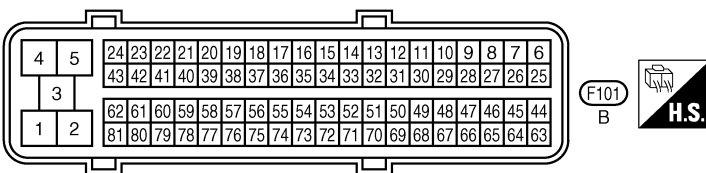
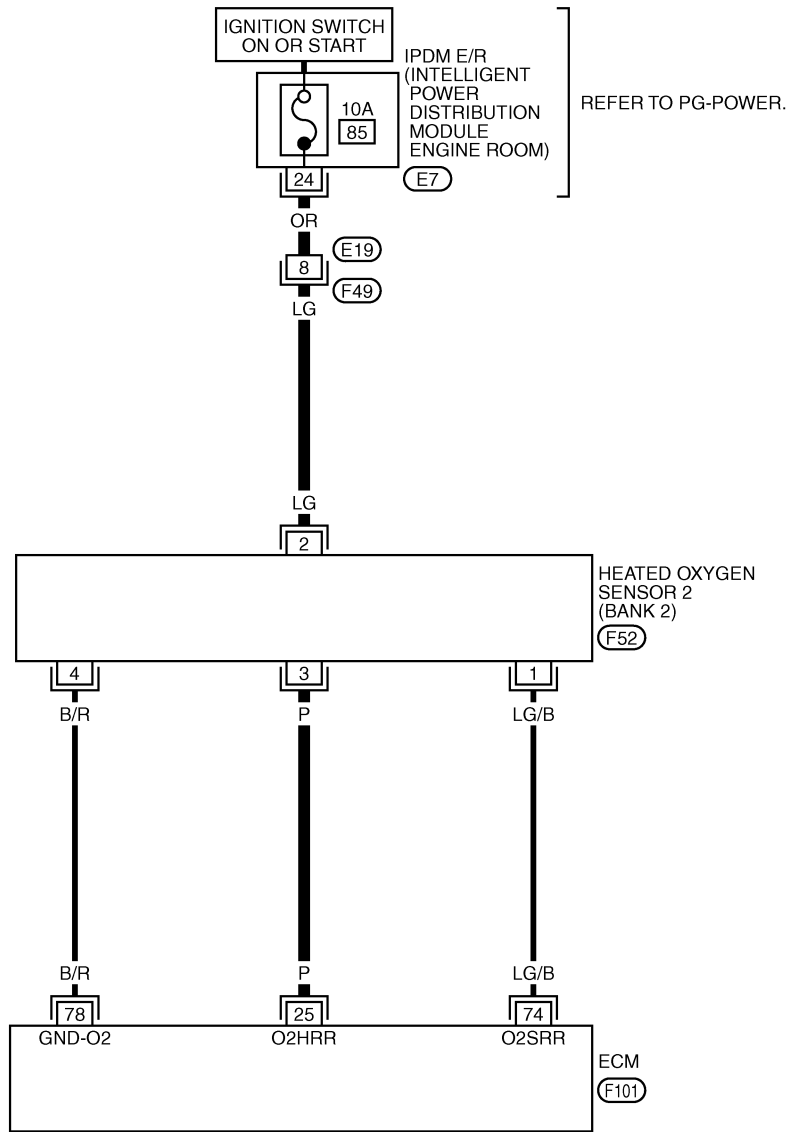

TBWM0224E

DTC P0037, P0038, P0057, P0058 HO2S2 HEATER

[VK45DE]

Specification data are reference values and are measured between each terminal and ground.

CAUTION:

Do not use ECM ground terminals when measuring input/output voltage. Doing so may result in damage to the ECM's transistor. Use a ground other than ECM terminals, such as the ground.

TER-MINAL NO.	WIRE COLOR	ITEM	CONDITION	DATA (DC Voltage)
25	P	Heated oxygen sensor 2 heater (bank 2)	[Engine is running] <ul style="list-style-type: none"> ● Engine speed is below 3,600 rpm after the following conditions are met <ul style="list-style-type: none"> - Engine: after warming up - Keeping the engine speed between 3,500 and 4,000 rpm for 1 minute and at idle for 1 minute under no load 	0 - 1.0V
			[Ignition switch: ON] <ul style="list-style-type: none"> ● Engine stopped [Engine is running] <ul style="list-style-type: none"> ● Engine speed is above 3,600 rpm 	BATTERY VOLTAGE (11 - 14V)

Diagnostic Procedure

ABS00C10

1. CHECK GROUND CONNECTIONS

1. Turn ignition switch OFF.
2. Loosen and retighten three ground screws on the body.
Refer to [EC-791, "Ground Inspection"](#).

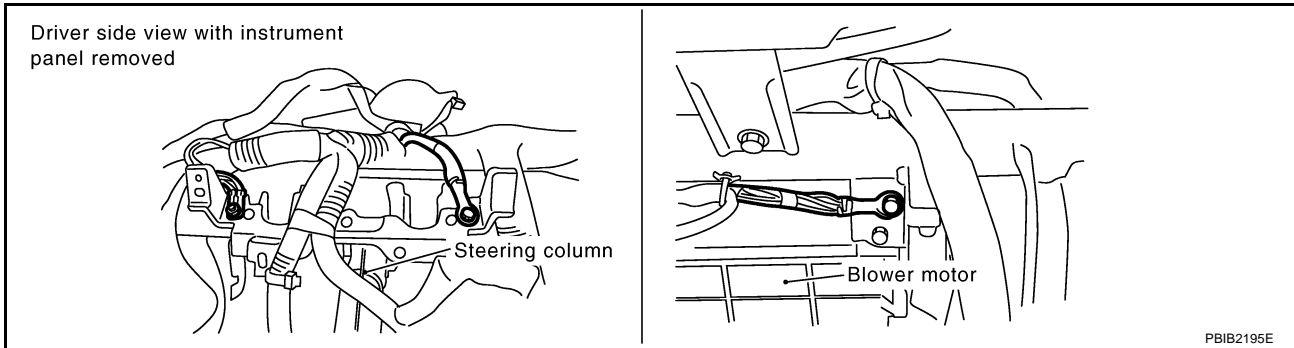

OK or NG

- OK >> GO TO 2.
- NG >> Repair or replace ground connections.

2. CHECK HO2S2 POWER SUPPLY CIRCUIT

1. Disconnect heated oxygen sensor 2 harness connector.

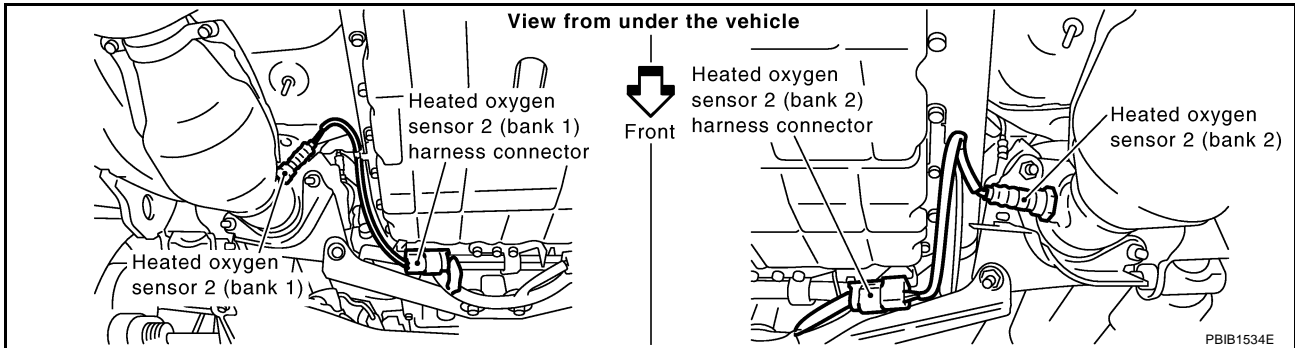

2. Turn ignition switch ON.
3. Check voltage between HO2S2 terminal 2 and ground with CONSULT-II or tester.

Voltage: Battery voltage

OK or NG

- OK >> GO TO 4.
- NG >> GO TO 3.

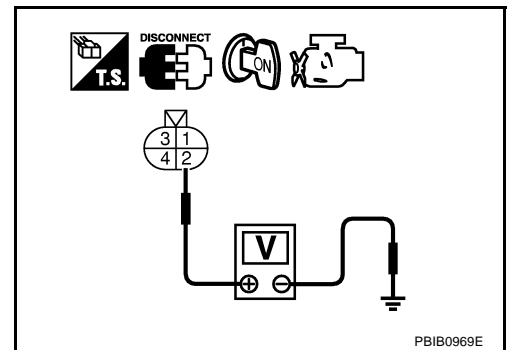

3. DETECT MALFUNCTIONING PART

Check the following.

- Harness connectors E19, E49
- IPDM E/R connector E7
- 10A fuse
- Harness for open or short between heated oxygen sensor 2 and fuse

>> Repair open circuit or short to ground or short to power in harness or connectors.

4. CHECK HO2S2 OUTPUT SIGNAL CIRCUIT FOR OPEN AND SHORT

1. Turn ignition switch OFF.
2. Disconnect ECM harness connector.
3. Check harness continuity between ECM terminal and HO2S2 terminal as follows. Refer to Wiring Diagram.

DTC	Terminals		Bank
	ECM	Sensor	
P0037, P0038	6	3	1
P0057, P0058	25	3	2

Continuity should exist.

4. Also check harness for short to ground and short to power.

OK or NG

- OK >> GO TO 5.
- NG >> Repair open circuit or short to ground or short to power in harness or connectors.

5. CHECK HEATED OXYGEN SENSOR 2 HEATER

Refer to [EC-821, "Component Inspection"](#) .

OK or NG

- OK >> GO TO 6.
- NG >> Replace malfunctioning heated oxygen sensor 2.

6. CHECK INTERMITTENT INCIDENT

Refer to [EC-784, "TROUBLE DIAGNOSIS FOR INTERMITTENT INCIDENT"](#) .

>> INSPECTION END

Component Inspection
HEATED OXYGEN SENSOR 2 HEATER

ABS00C11

1. Check resistance between HO2S2 terminals as follows.

Terminal No.	Resistance
2 and 3	5.0 - 7.0 Ω at 25°C (77°F)
1 and 2, 3, 4	∞ Ω
4 and 1, 2, 3	(Continuity should not exist)

2. If NG, replace heated oxygen sensor 2.

CAUTION:

- Discard any heated oxygen sensor which has been dropped from a height of more than 0.5 m (19.7 in) onto a hard surface such as a concrete floor; use a new one.
- Before installing new oxygen sensor, clean exhaust system threads using Oxygen Sensor Thread Cleaner tool J-43897-18 or J-43897-12 and approved anti-seize lubricant.

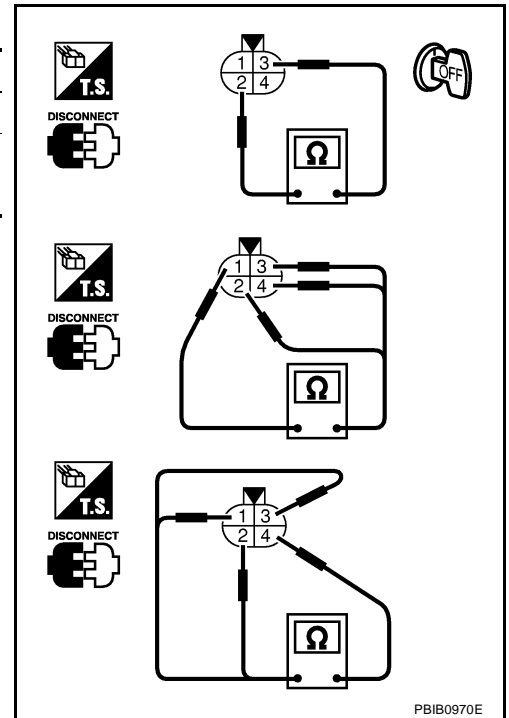

PBIB0970E

Removal and Installation
HEATED OXYGEN SENSOR 2

ABS00C12

Refer to [EM-178, "EXHAUST MANIFOLD AND THREE WAY CATALYST"](#) .

DTC P0101 MAF SENSOR

PFP:22680

Component Description

ABS00C13

The mass air flow sensor is placed in the stream of intake air. It measures the intake flow rate by measuring a part of the entire intake flow. It consists of a hot film that is supplied with electric current from the ECM. The temperature of the hot film is controlled by the ECM a certain amount. The heat generated by the hot film is reduced as the intake air flows around it. The more air, the greater the heat loss. Therefore, the ECM must supply more electric current to maintain the temperature of the hot film as air flow increases. The ECM detects the air flow by means of this current change.

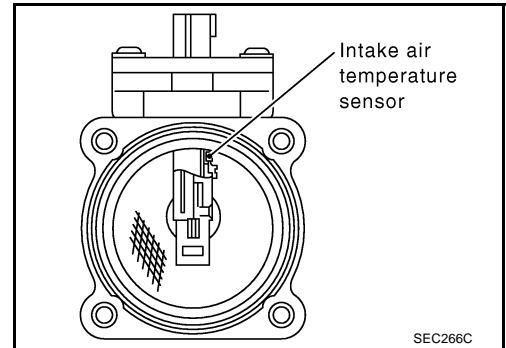

CONSULT-II Reference Value in Data Monitor Mode

ABS00C14

Specification data are reference values.

MONITOR ITEM	CONDITION		SPECIFICATION
MAS A/F SE-B1	See EC-780, "TROUBLE DIAGNOSIS - SPECIFICATION VALUE" .		
CAL/LD VALUE	<ul style="list-style-type: none"> ● Engine: After warming up ● Air conditioner switch: OFF ● Shift lever: N ● No load 	Idle	14% - 33%
		2,500 rpm	12% - 25%
MASS AIRFLOW	<ul style="list-style-type: none"> ● Engine: After warming up ● Air conditioner switch: OFF ● Shift lever: N ● No load 	Idle	2.0 - 6.0 g-m/s
		2,500 rpm	7.0 - 20.0 g-m/s

On Board Diagnosis Logic

ABS00C15

This self-diagnosis has the one trip detection logic.

NOTE:

If DTC P0101 is displayed with DTC P1229, first perform the trouble diagnosis for DTC P1229. Refer to [EC-1156](#) .

DTC No.	Trouble diagnosis name	DTC detecting condition		Possible cause
P0101 0101	Mass air flow sensor circuit range/performance problem	A)	A high voltage from the sensor is sent to ECM under light load driving condition.	<ul style="list-style-type: none"> ● Harness or connectors (The sensor circuit is open or shorted.) ● Mass air flow sensor
		B)	A low voltage from the sensor is sent to ECM under heavy load driving condition.	<ul style="list-style-type: none"> ● Harness or connectors (The sensor circuit is open or shorted.) ● Intake air leaks ● Mass air flow sensor

DTC Confirmation Procedure

Perform PROCEDURE FOR MALFUNCTION A first.

If the DTC cannot be confirmed, perform PROCEDURE FOR MALFUNCTION B.

NOTE:

If DTC Confirmation Procedure has been previously conducted, always turn ignition switch OFF and wait at least 10 seconds before conducting the next test.

PROCEDURE FOR MALFUNCTION A

NOTE:

If engine will not start or stops soon, wait at least 10 seconds with engine stopped (Ignition switch ON) instead of running engine at idle speed.

With CONSULT-II

1. Turn ignition switch ON.
2. Select "DATA MONITOR" mode with CONSULT-II.
3. Start engine and warm it up to normal operating temperature.
4. Run engine for at least 10 seconds at idle speed.
5. If DTC is detected, go to [EC-826, "Diagnostic Procedure"](#) .

DATA MONITOR	
MONITOR	NO DTC
ENG SPEED	XXX rpm
COOLAN TEMP/S	XXX °C

SEF174Y

With GST

Follow the procedure "With CONSULT-II" above.

PROCEDURE FOR MALFUNCTION B

CAUTION:

Always drive vehicle at a safe speed.

With CONSULT-II

1. Turn ignition switch ON.
2. Start engine and warm it up to normal operating temperature.
If engine cannot be started, go to [EC-826, "Diagnostic Procedure"](#) .
3. Select "DATA MONITOR" mode with CONSULT-II.
4. Check the voltage of "MAS A/F SE-B1" with "DATA MONITOR".
5. Increases engine speed to about 4,000 rpm.
6. Monitor the linear voltage rise in response to engine speed increases.
If NG, go to [EC-826, "Diagnostic Procedure"](#) .
If OK, go to following step.

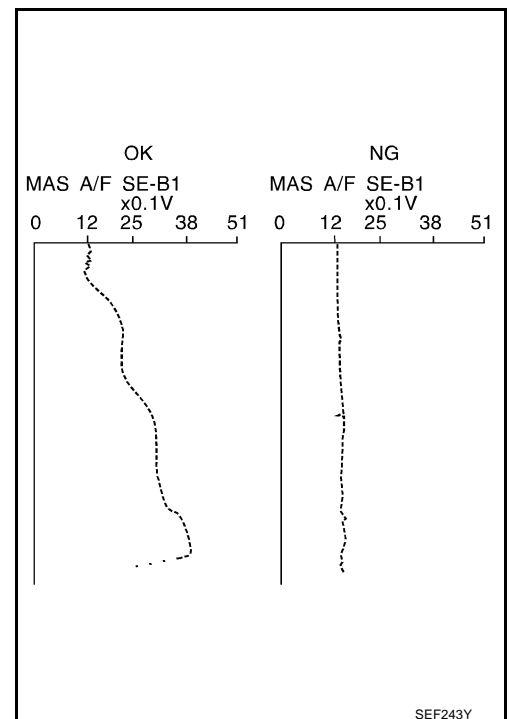

DTC P0101 MAF SENSOR

[VK45DE]

7. Maintain the following conditions for at least 10 consecutive seconds.

ENG SPEED	More than 2,000 rpm
THRTL SEN 1	More than 3V
THRTL SEN 2	More than 3V
Selector lever	Suitable position
Driving location	Driving vehicle uphill (Increased engine load) will help maintain the driving conditions required for this test.

8. If DTC is detected, go to [EC-826, "Diagnostic Procedure"](#).

DATA MONITOR	
MONITOR	NO DTC
ENG SPEED	XXX rpm
VHCL SPEED SE	XXX km/h
THRTL SEN 1	XXX V
THRTL SEN 2	XXX V

PBIB0199E

Overall Function Check PROCEDURE FOR MALFUNCTION B

ABS00C17

Use this procedure to check the overall function of the mass air flow sensor circuit. During this check, a DTC might not be confirmed.

With GST

1. Start engine and warm it up to normal operating temperature.
2. Select MODE 1 with GST.
3. Check the mass air flow sensor signal with MODE 1.
4. Check for linear mass air flow sensor signal value rise in response to increases to about 4,000 rpm in engine speed.
5. If NG, go to [EC-826, "Diagnostic Procedure"](#).

CALC LOAD	20%
COOLANT TEMP	95°C
SHORT FT #1	2%
LONG FT #1	0%
SHORT FT #2	4%
LONG FT #2	0%
ENGINE SPD	2637RPM
VEHICLE SPD	0MPH
IGN ADVANCE	41.0°
INTAKE AIR	41°C
MAF	14.1gm/sec
THROTTLE POS	3%

SEF534P

DTC P0101 MAF SENSOR

[VK45DE]

Wiring Diagram

ABS00C18

EC-MAFS-01

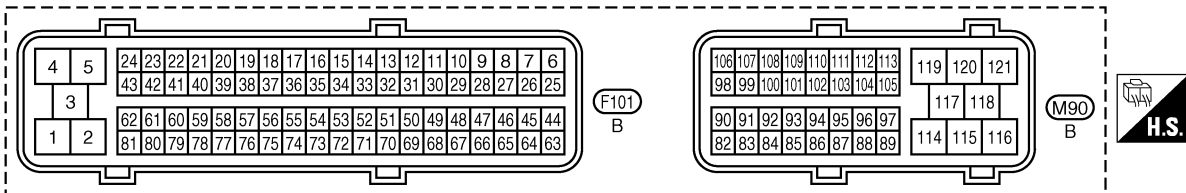
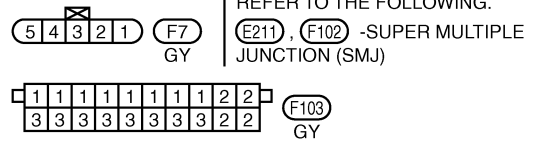
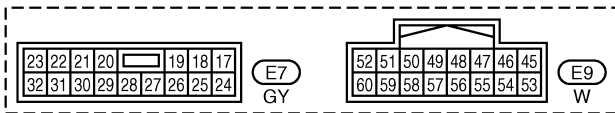
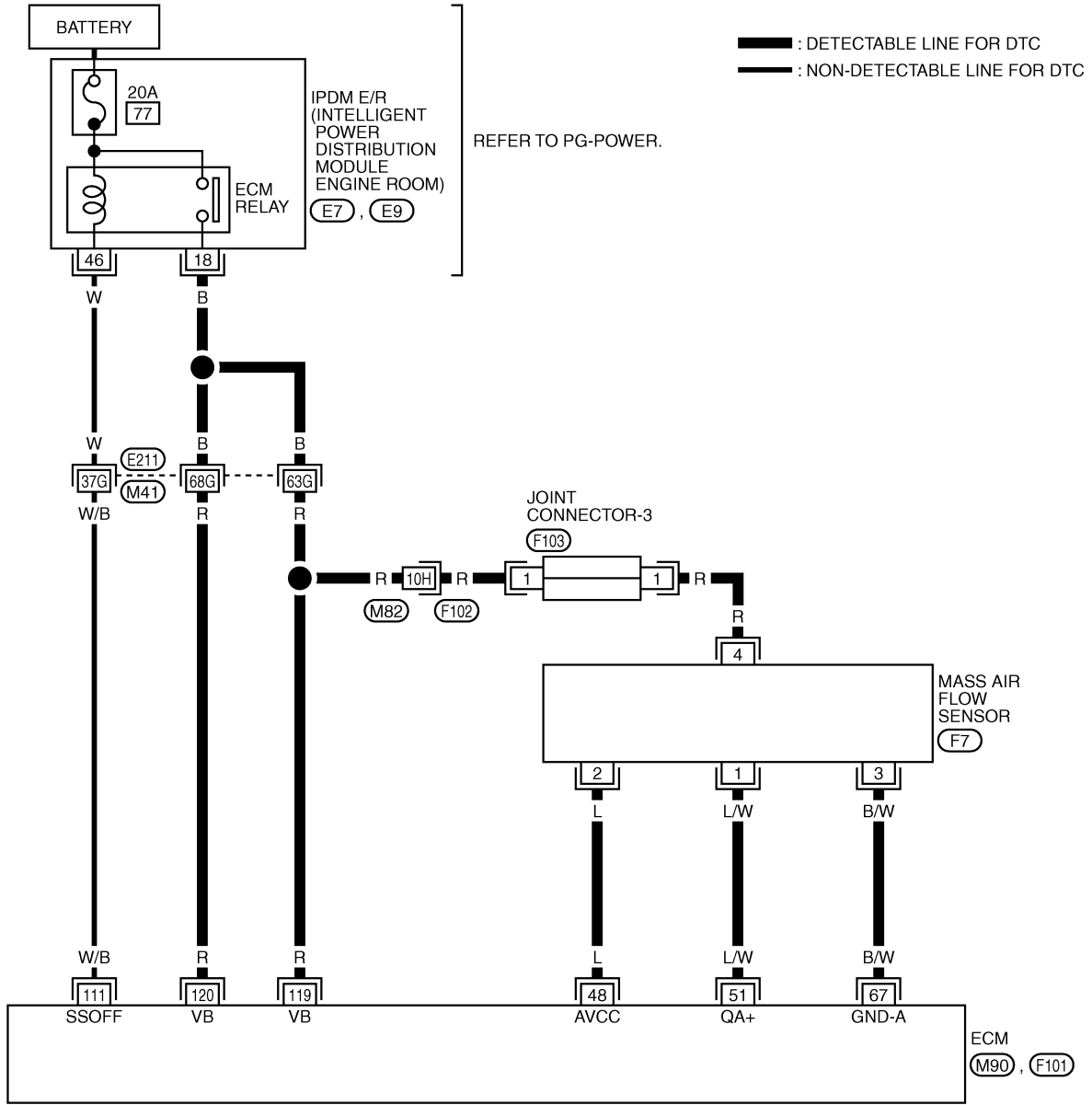

TBWM0225E

DTC P0101 MAF SENSOR

[VK45DE]

Specification data are reference values and are measured between each terminal and ground.

CAUTION:

Do not use ECM ground terminals when measuring input/output voltage. Doing so may result in damage to the ECM's transistor. Use a ground other than ECM terminals, such as the ground.

TERMINAL NO.	WIRE COLOR	ITEM	CONDITION	DATA (DC Voltage)
48	L	Sensor power supply (Mass air flow sensor)	[Ignition switch: ON]	Approximately 5V
51	L/W	Mass air flow sensor	[Engine is running] ● Warm-up condition ● Idle speed	1.2 - 1.8V
			[Engine is running] ● Warm-up condition ● Engine speed is 2,500 rpm	1.7 - 2.4V
67	B/W	Sensor ground (Mass air flow sensor / IAT sensor / Power steering pressure sensor / EVAP control system pressure sensor / Refrigerant pressure sensor / ECT sensor)	[Engine is running] ● Warm-up condition ● Idle speed	Approximately 0V
111	W/B	ECM relay (Self shut-off)	[Engine is running] [Ignition switch: OFF] ● For a few seconds after turning ignition switch OFF	0 - 1.5V
			[Ignition switch: OFF] ● More than a few seconds after turning ignition switch OFF	BATTERY VOLTAGE (11 - 14V)
119 120	R R	Power supply for ECM	[Ignition switch: ON]	BATTERY VOLTAGE (11 - 14V)

Diagnostic Procedure

ABS00C19

1. INSPECTION START

Which malfunction (A or B) is duplicated?

A or B

- A >> GO TO 3.
- B >> GO TO 2.

2. CHECK INTAKE SYSTEM

Check the following for connection.

- Air duct
- Vacuum hoses
- Intake air passage between air duct to intake manifold

OK or NG

- OK >> GO TO 3.
- NG >> Reconnect the parts.

3. CHECK GROUND CONNECTIONS

1. Turn ignition switch OFF.
2. Loosen and retighten three ground screws on the body.
Refer to [EC-791, "Ground Inspection"](#).

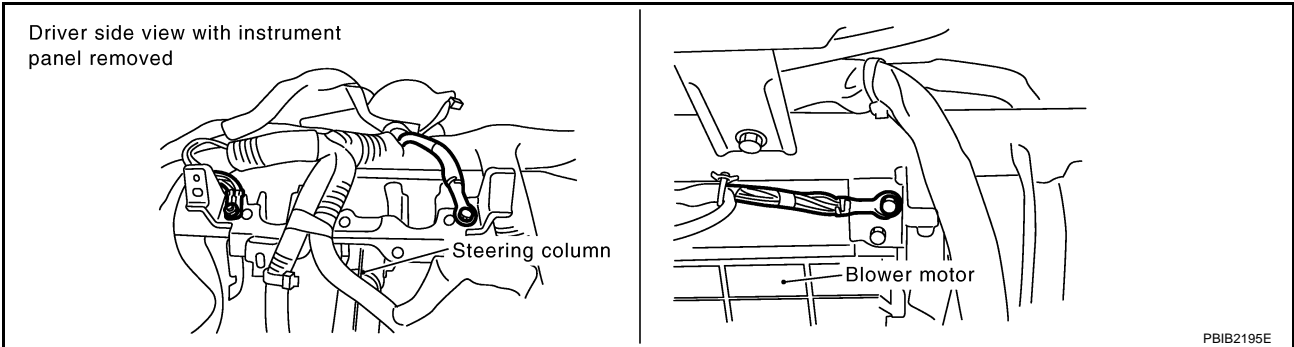

OK or NG

- OK >> GO TO 4.
- NG >> Repair or replace ground connections.

4. CHECK MAF SENSOR POWER SUPPLY CIRCUIT

1. Disconnect mass air flow (MAF) sensor harness connector.
2. Turn ignition switch ON.

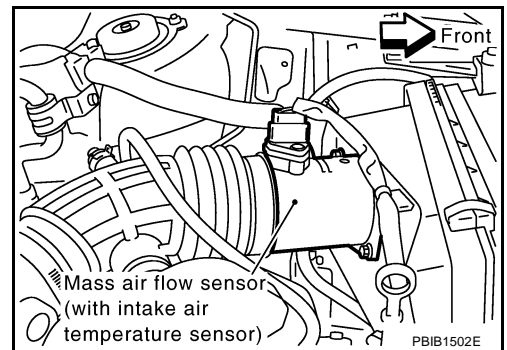

3. Check voltage between MAF sensor terminals 2, 4 and ground with CONSULT-II or tester.

Terminal	Voltage
2	Approximately 5V
4	Battery voltage

OK or NG

- OK >> GO TO 6.
- NG >> GO TO 5.

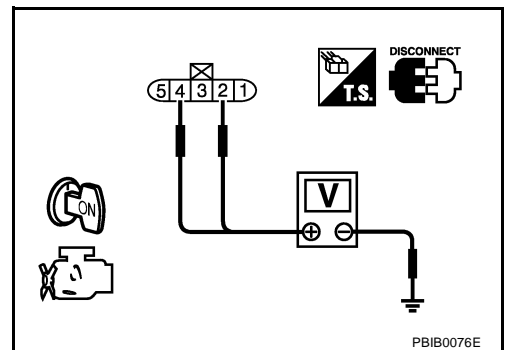

5. DETECT MALFUNCTIONING PART

Check the following.

- Harness connectors E211, M41
- Harness connectors M82, F102
- Joint connector-3
- Harness for open or short between IPDM E/R and mass air flow sensor
- Harness for open or short between mass air flow sensor and ECM

>> Repair open circuit or short to ground or short to power in harness or connectors.

6. CHECK MAF SENSOR GROUND CIRCUIT FOR OPEN AND SHORT

1. Turn ignition switch OFF.
2. Disconnect ECM harness connector.
3. Check harness continuity between MAF sensor terminal 3 and ECM terminal 67.
Refer to Wiring Diagram.

Continuity should exist.

4. Also check harness for short to ground and short to power.

OK or NG

OK >> GO TO 7.

NG >> Repair open circuit or short to ground or short to power in harness or connectors.

7. CHECK MAF SENSOR INPUT SIGNAL CIRCUIT FOR OPEN AND SHORT

1. Check harness continuity between MAF sensor terminal 1 and ECM terminal 51.
Refer to Wiring Diagram.

Continuity should exist.

2. Also check harness for short to ground and short to power.

OK or NG

OK >> GO TO 8.

NG >> Repair open circuit or short to ground or short to power in harness or connectors.

8. CHECK MASS AIR FLOW SENSOR

Refer to [EC-829, "Component Inspection"](#) .

OK or NG

OK >> GO TO 9.

NG >> Replace mass air flow sensor.

9. CHECK INTERMITTENT INCIDENT

Refer to [EC-784, "TROUBLE DIAGNOSIS FOR INTERMITTENT INCIDENT"](#) .

>> INSPECTION END

Component Inspection MASS AIR FLOW SENSOR

1. Reconnect all harness connectors disconnected.
2. Start engine and warm it up to normal operating temperature.
3. Check voltage between ECM terminal 51 (Mass air flow sensor signal) and ground.

Condition	Voltage V
Ignition switch ON (Engine stopped.)	Approx. 1.0
Idle (Engine is warmed-up to normal operating temperature.)	1.2 - 1.8
2,500 rpm (Engine is warmed-up to normal operating temperature.)	1.7 - 2.4
Idle to about 4,000 rpm*	1.2 - 1.8 to Approx. 4.0

*: Check for linear voltage rise in response to engine being increased to about 4,000 rpm.

4. If the voltage is out of specification, proceed the following.
 - Turn ignition switch OFF.
 - Disconnect mass air flow sensor harness connector and reconnect it again.
 - Perform steps 2 and 3 again.
5. If NG, remove mass air flow sensor from air duct. Check hot film for damage or dust.
6. If NG, clean or replace mass air flow sensor.

Removal and Installation MASS AIR FLOW SENSOR

Refer to [EM-172, "AIR CLEANER AND AIR DUCT"](#) .

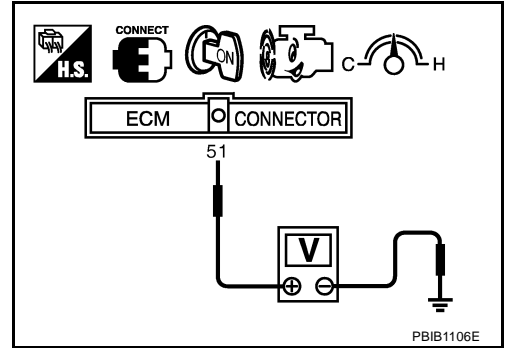

A
EC
C
D
E
F
G
H
I
J
K
L
M

DTC P0102, P0103 MAF SENSOR

PFP:22680

Component Description

ABS00C1C

The mass air flow sensor is placed in the stream of intake air. It measures the intake flow rate by measuring a part of the entire intake flow. It consists of a hot film that is supplied with electric current from the ECM. The temperature of the hot film is controlled by the ECM a certain amount. The heat generated by the hot film is reduced as the intake air flows around it. The more air, the greater the heat loss. Therefore, the ECM must supply more electric current to maintain the temperature of the hot film as air flow increases. The ECM detects the air flow by means of this current change.

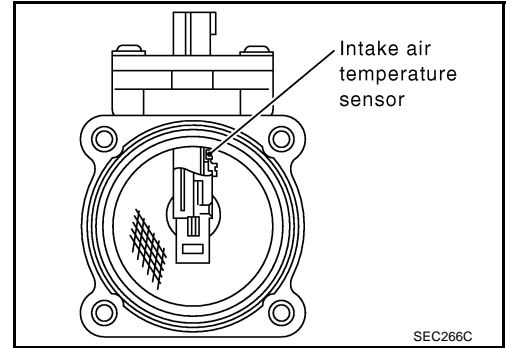

CONSULT-II Reference Value in Data Monitor Mode

ABS00C1D

Specification data are reference values.

MONITOR ITEM	CONDITION	SPECIFICATION
MAS A/F SE-B1	See EC-780, "TROUBLE DIAGNOSIS - SPECIFICATION VALUE" .	
CAL/LD VALUE	<ul style="list-style-type: none"> ● Engine: After warming up ● Air conditioner switch: OFF 	Idle 14% - 33%
	<ul style="list-style-type: none"> ● Shift lever: N ● No load 	2,500 rpm 12% - 25%
MASS AIRFLOW	<ul style="list-style-type: none"> ● Engine: After warming up ● Air conditioner switch: OFF 	Idle 2.0 - 6.0 g-m/s
	<ul style="list-style-type: none"> ● Shift lever: N ● No load 	2,500 rpm 7.0 - 20.0 g-m/s

On Board Diagnosis Logic

ABS00C1E

These self-diagnoses have the one trip detection logic.

NOTE:

If DTC P0102 or P0103 is displayed with DTC P1229, first perform the trouble diagnosis for DTC P1229. Refer to [EC-1156](#) .

DTC No.	Trouble diagnosis name	DTC detecting condition	Possible cause
P0102 0102	Mass air flow sensor circuit low input	An excessively low voltage from the sensor is sent to ECM.	<ul style="list-style-type: none"> ● Harness or connectors (The sensor circuit is open or shorted.) ● Intake air leaks ● Mass air flow sensor
P0103 0103	Mass air flow sensor circuit high input	An excessively high voltage from the sensor is sent to ECM.	<ul style="list-style-type: none"> ● Harness or connectors (The sensor circuit is open or shorted.) ● Mass air flow sensor

FAIL-SAFE MODE

When the malfunction is detected, the ECM enters fail-safe mode and the MIL lights up.

Detected items	Engine operating condition in fail-safe mode
Mass air flow sensor circuit	Engine speed will not rise more than 2,400 rpm due to the fuel cut.

DTC Confirmation Procedure

NOTE:

If DTC Confirmation Procedure has been previously conducted, always turn ignition switch OFF and wait at least 10 seconds before conducting the next test.

PROCEDURE FOR DTC P0102

With CONSULT-II

1. Turn ignition switch ON.
2. Select "DATA MONITOR" mode with CONSULT-II.
3. Start engine and wait at least 5 seconds.
4. If DTC is detected, go to [EC-833, "Diagnostic Procedure"](#) .

DATA MONITOR	
MONITOR	NO DTC
ENG SPEED	XXX rpm

SEF058Y

With GST

Follow the procedure "With CONSULT-II" above.

PROCEDURE FOR DTC P0103

With CONSULT-II

1. Turn ignition switch ON.
2. Select "DATA MONITOR" mode with CONSULT-II.
3. Wait at least 5 seconds.
4. If DTC is detected, go to [EC-833, "Diagnostic Procedure"](#) .
If DTC is not detected, go to next step.
5. Start engine and wait at least 5 seconds.
6. If DTC is detected, go to [EC-833, "Diagnostic Procedure"](#) .

DATA MONITOR	
MONITOR	NO DTC
ENG SPEED	XXX rpm

SEF058Y

With GST

Follow the procedure "With CONSULT-II" above.

A
EC
C
D
E
F
G
H
I
J
K
L
M

DTC P0102, P0103 MAF SENSOR

[VK45DE]

ABS00C1G

Wiring Diagram

EC-MAFS-01

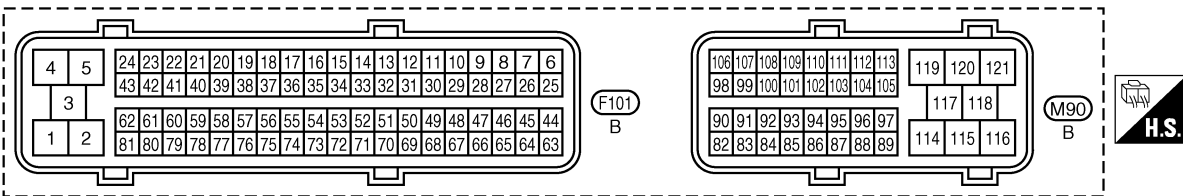
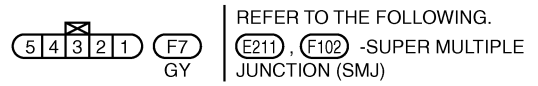
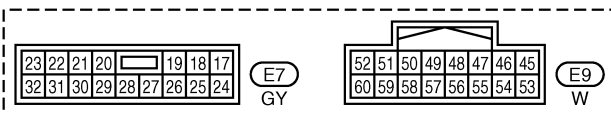
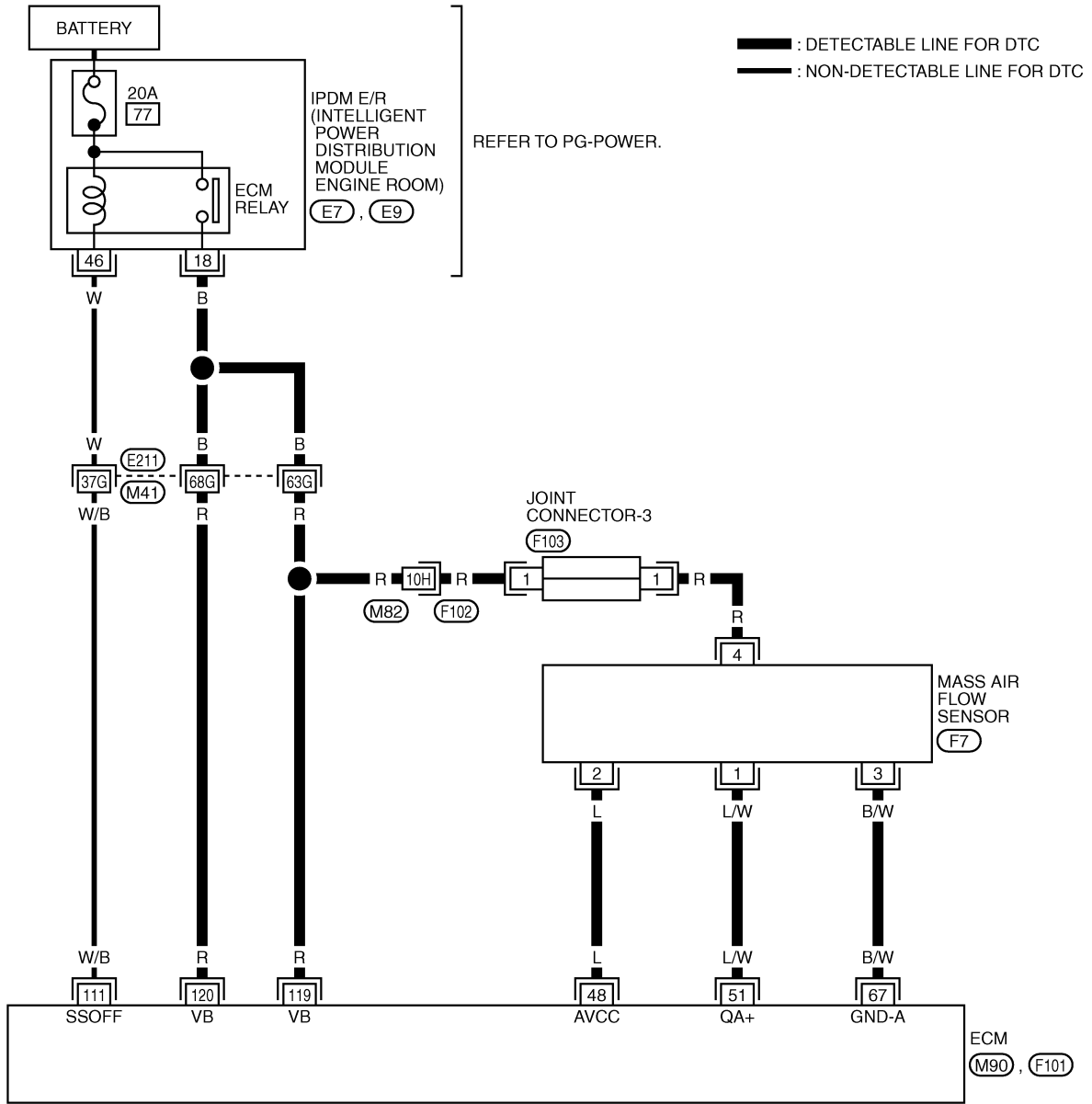

TBWM0225E

DTC P0102, P0103 MAF SENSOR

[VK45DE]

Specification data are reference values and are measured between each terminal and ground.

CAUTION:

Do not use ECM ground terminals when measuring input/output voltage. Doing so may result in damage to the ECM's transistor. Use a ground other than ECM terminals, such as the ground.

TER-MINAL NO.	WIRE COLOR	ITEM	CONDITION	DATA (DC Voltage)
48	L	Sensor power supply (Mass air flow sensor)	[Ignition switch: ON]	Approximately 5V
51	L/W	Mass air flow sensor	[Engine is running] ● Warm-up condition ● Idle speed	1.2 - 1.8V
			[Engine is running] ● Warm-up condition ● Engine speed is 2,500 rpm	1.7 - 2.4V
67	B/W	Sensor ground (Mass air flow sensor / IAT sensor / Power steering pressure sensor / EVAP control system pressure sensor / Refrigerant pressure sensor / ECT sensor)	[Engine is running] ● Warm-up condition ● Idle speed	Approximately 0V
111	W/B	ECM relay (Self shut-off)	[Engine is running] [Ignition switch: OFF] ● For a few seconds after turning ignition switch OFF	0 - 1.5V
			[Ignition switch: OFF] ● More than a few seconds after turning ignition switch OFF	BATTERY VOLTAGE (11 - 14V)
119 120	R R	Power supply for ECM	[Ignition switch: ON]	BATTERY VOLTAGE (11 - 14V)

Diagnostic Procedure

ABS00C1H

1. INSPECTION START

Which malfunction (P0102 or P0103) is duplicated?

P0102 or P0103

- P0102 >> GO TO 2.
- P0103 >> GO TO 3.

2. CHECK INTAKE SYSTEM

Check the following for connection.

- Air duct
- Vacuum hoses
- Intake air passage between air duct to intake manifold

OK or NG

- OK >> GO TO 3.
- NG >> Reconnect the parts.

3. CHECK GROUND CONNECTIONS

1. Turn ignition switch OFF.
2. Loosen and retighten three ground screws on the body.
Refer to [EC-791, "Ground Inspection"](#).

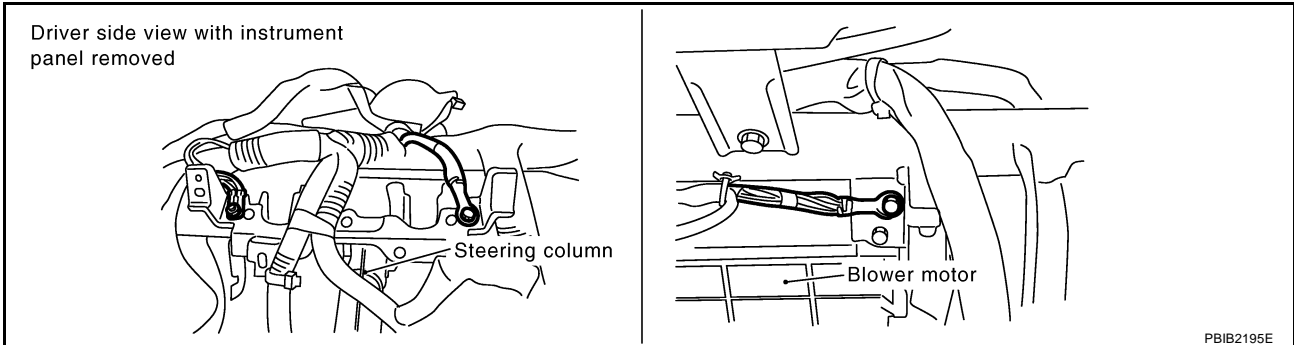

OK or NG

- OK >> GO TO 4.
- NG >> Repair or replace ground connections.

4. CHECK MAF SENSOR POWER SUPPLY CIRCUIT

1. Disconnect mass air flow (MAF) sensor harness connector.
2. Turn ignition switch ON.

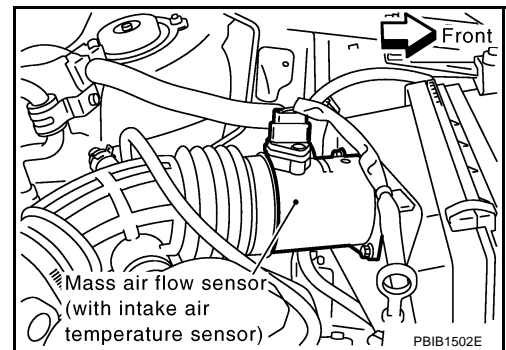

3. Check voltage between MAF sensor terminals 2, 4 and ground with CONSULT-II or tester.

Terminal	Voltage
2	Approximately 5V
4	Battery voltage

OK or NG

- OK >> GO TO 6.
- NG >> GO TO 5.

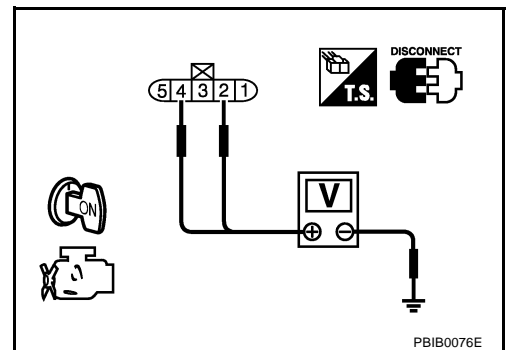

5. DETECT MALFUNCTIONING PART

Check the following.

- Harness connectors E211, M41
- Harness connectors M82, F102
- Joint connector-3
- Harness for open or short between IPDM E/R and mass air flow sensor
- Harness for open or short between mass air flow sensor and ECM

>> Repair open circuit or short to ground or short to power in harness or connectors.

6. CHECK MAF SENSOR GROUND CIRCUIT FOR OPEN AND SHORT

1. Turn ignition switch OFF.
2. Disconnect ECM harness connector.
3. Check harness continuity between MAF sensor terminal 3 and ECM terminal 67.
Refer to Wiring Diagram.

Continuity should exist.

4. Also check harness for short to ground and short to power.

OK or NG

OK >> GO TO 7.

NG >> Repair open circuit or short to ground or short to power in harness or connectors.

7. CHECK MAF SENSOR INPUT SIGNAL CIRCUIT FOR OPEN AND SHORT

1. Check harness continuity between MAF sensor terminal 1 and ECM terminal 51.
Refer to Wiring Diagram.

Continuity should exist.

2. Also check harness for short to ground and short to power.

OK or NG

OK >> GO TO 8.

NG >> Repair open circuit or short to ground or short to power in harness or connectors.

8. CHECK MASS AIR FLOW SENSOR

Refer to [EC-829, "Component Inspection"](#) .

OK or NG

OK >> GO TO 9.

NG >> Replace mass air flow sensor.

9. CHECK INTERMITTENT INCIDENT

Refer to [EC-784, "TROUBLE DIAGNOSIS FOR INTERMITTENT INCIDENT"](#) .

>> INSPECTION END

Component Inspection
MASS AIR FLOW SENSOR

1. Reconnect all harness connectors disconnected.
2. Start engine and warm it up to normal operating temperature.
3. Check voltage between ECM terminal 51 (Mass air flow sensor signal) and ground.

Condition	Voltage V
Ignition switch ON (Engine stopped.)	Approx. 1.0
Idle (Engine is warmed-up to normal operating temperature.)	1.2 - 1.8
2,500 rpm (Engine is warmed-up to normal operating temperature.)	1.7 - 2.4
Idle to about 4,000 rpm*	1.2 - 1.8 to Approx. 4.0

*: Check for linear voltage rise in response to engine being increased to about 4,000 rpm.

4. If the voltage is out of specification, proceed the following.
 - Turn ignition switch OFF.
 - Disconnect mass air flow sensor harness connector and reconnect it again.
 - Perform steps 2 and 3 again.
5. If NG, remove mass air flow sensor from air duct. Check hot film for damage or dust.
6. If NG, clean or replace mass air flow sensor.

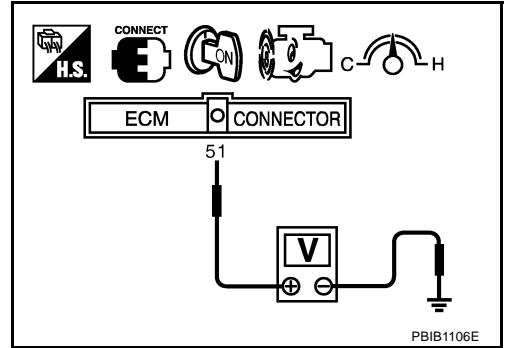

Removal and Installation
MASS AIR FLOW SENSOR

Refer to [EM-172. "AIR CLEANER AND AIR DUCT"](#) .

DTC P0112, P0113 IAT SENSOR

PFP:22630

Component Description

ABS00C1K

The intake air temperature sensor is built-into mass air flow sensor. The sensor detects intake air temperature and transmits a signal to the ECM.

The temperature sensing unit uses a thermistor which is sensitive to the change in temperature. Electrical resistance of the thermistor decreases in response to the temperature rise.

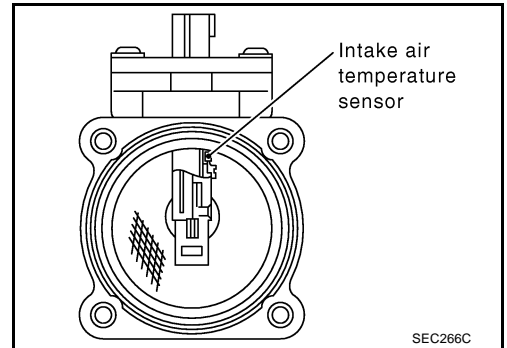

<Reference data>

Intake air temperature °C (°F)	Voltage* V	Resistance kΩ
-10 (14)	4.43	7.9 - 9.3
25 (77)	3.32	1.9 - 2.1
80 (176)	1.23	0.31 - 0.37

*: These data are reference values and are measured between ECM terminal 34 (Intake air temperature sensor) and ground.

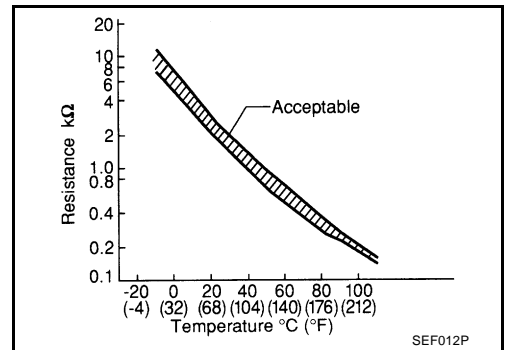

CAUTION:

Do not use ECM ground terminals when measuring input/output voltage. Doing so may result in damage to the ECM's transistor. Use a ground other than ECM terminals, such as the ground.

On Board Diagnosis Logic

ABS00C1L

DTC No.	Trouble diagnosis name	DTC detecting condition	Possible cause
P0112 0112	Intake air temperature sensor circuit low input	An excessively low voltage from the sensor is sent to ECM.	<ul style="list-style-type: none"> ● Harness or connectors (The sensor circuit is open or shorted.) ● Intake air temperature sensor
P0113 0113	Intake air temperature sensor circuit high input	An excessively high voltage from the sensor is sent to ECM.	

DTC Confirmation Procedure

ABS00C1M

NOTE:

If DTC Confirmation Procedure has been previously conducted, always turn ignition switch OFF and wait at least 10 seconds before conducting the next test.

WITH CONSULT-II

1. Turn ignition switch ON.
2. Select "DATA MONITOR" mode with CONSULT-II.
3. Wait at least 5 seconds.
4. If 1st trip DTC is detected, go to [EC-840, "Diagnostic Procedure"](#)

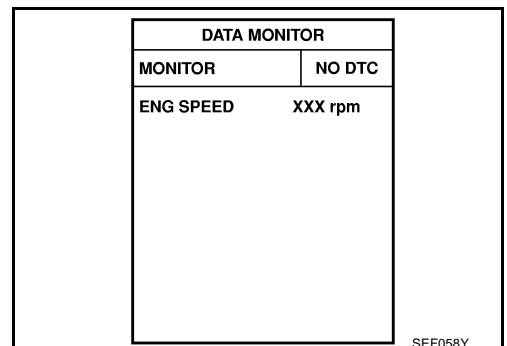

 **WITH GST**

Follow the procedure "WITH CONSULT-II" above.

DTC P0112, P0113 IAT SENSOR

[VK45DE]

Wiring Diagram

ABS00C1N

EC-IATS-01

: DETECTABLE LINE FOR DTC
 : NON-DETECTABLE LINE FOR DTC

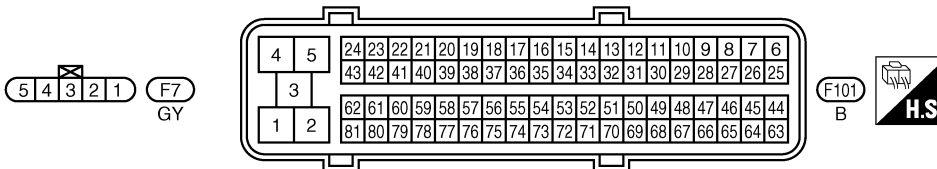
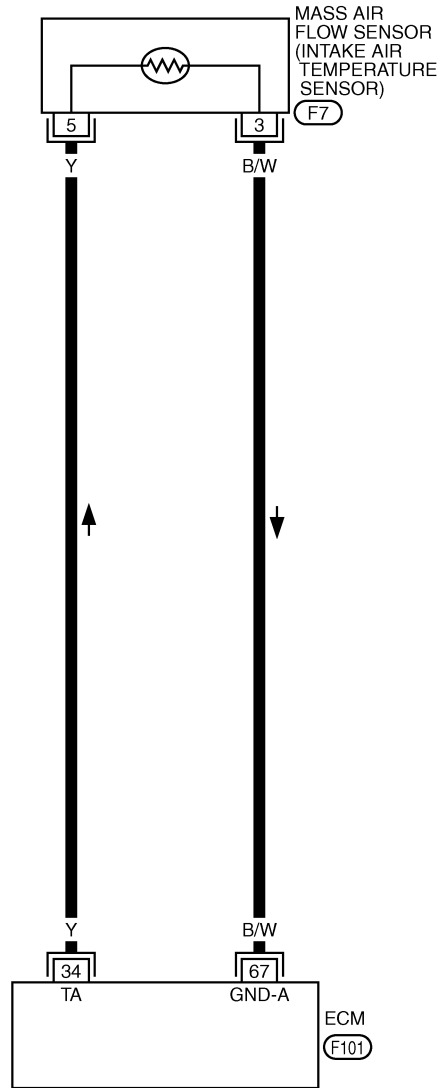

TBWM0226E

Diagnostic Procedure

1. CHECK GROUND CONNECTIONS

1. Turn ignition switch OFF.
2. Loosen and retighten three ground screws on the body.
Refer to [EC-791, "Ground Inspection"](#).

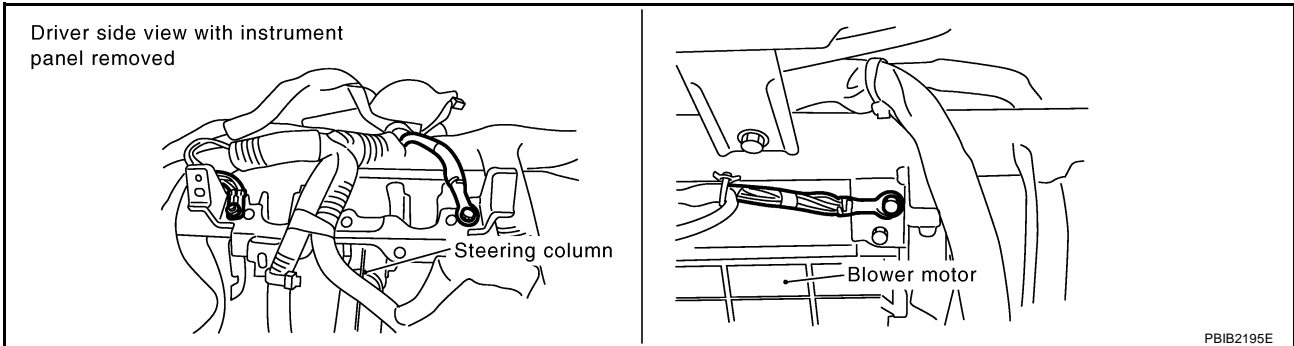

OK or NG

- OK >> GO TO 2.
- NG >> Repair or replace ground connections.

2. CHECK INTAKE AIR TEMPERATURE SENSOR POWER SUPPLY CIRCUIT

1. Disconnect mass air flow sensor (intake air temperature sensor is built-into) harness connector.
2. Turn ignition switch ON.

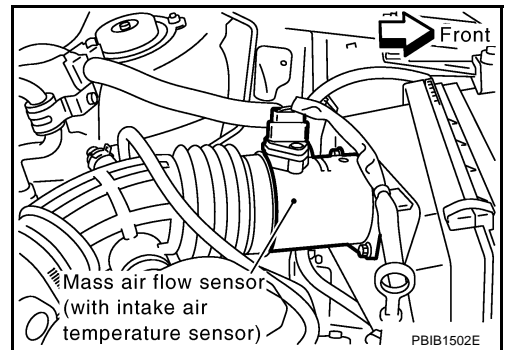

3. Check voltage between mass air flow sensor terminal 5 and ground.

Voltage: Approximately 5V

OK or NG

- OK >> GO TO 3.
- NG >> Repair open circuit or short to ground or short to power in harness or connectors.

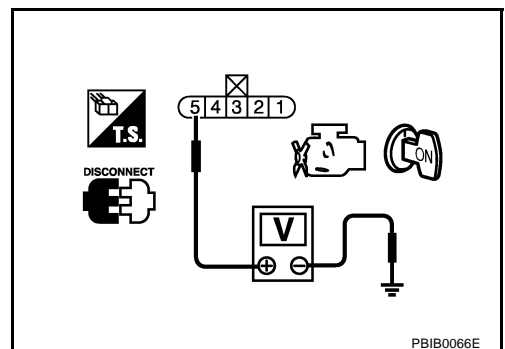

3. CHECK INTAKE AIR TEMPERATURE SENSOR GROUND CIRCUIT FOR OPEN AND SHORT

1. Turn ignition switch OFF.
2. Disconnect ECM harness connector.
3. Check harness continuity between mass air flow sensor terminal 3 and ECM terminal 67.
Refer to Wiring Diagram.

Continuity should exist.

4. Also check harness for short to ground and short to power.

OK or NG

- OK >> GO TO 4.
- NG >> Repair open circuit or short to ground or short to power in harness or connectors.

4. CHECK INTAKE AIR TEMPERATURE SENSOR

Refer to [EC-841, "Component Inspection"](#) .

OK or NG

- OK >> GO TO 5.
- NG >> Replace mass air flow sensor (with intake air temperature sensor).

5. CHECK INTERMITTENT INCIDENT

Refer to [EC-784, "TROUBLE DIAGNOSIS FOR INTERMITTENT INCIDENT"](#) .

>> **INSPECTION END**

**Component Inspection
INTAKE AIR TEMPERATURE SENSOR**

ABS00C1P

1. Check resistance between mass air flow sensor terminals 5 and 6 under the following conditions.

Intake air temperature °C (°F)	Resistance kΩ
25 (77)	1.9 - 2.1

2. If NG, replace mass air flow sensor (with intake air temperature sensor).

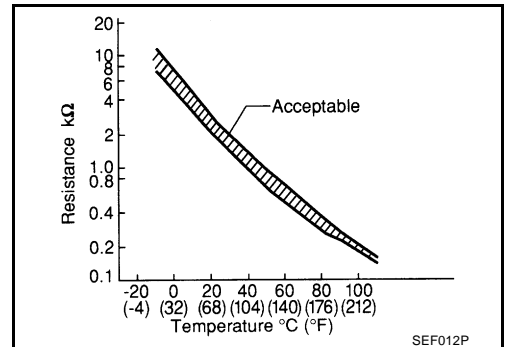
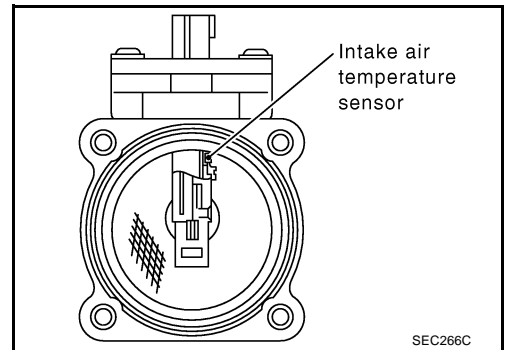

**Removal and Installation
MASS AIR FLOW SENSOR**

ABS00C1Q

Refer to [EM-172, "AIR CLEANER AND AIR DUCT"](#) .

DTC P0117, P0118 ECT SENSOR

PFP:22630

Component Description

ABS00C1R

The engine coolant temperature sensor is used to detect the engine coolant temperature. The sensor modifies a voltage signal from the ECM. The modified signal returns to the ECM as the engine coolant temperature input. The sensor uses a thermistor which is sensitive to the change in temperature. The electrical resistance of the thermistor decreases as temperature increases.

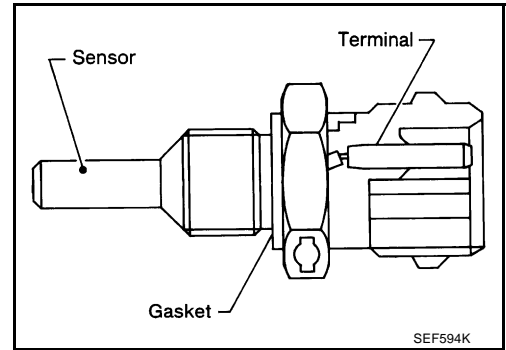

<Reference data>

Engine coolant temperature °C (°F)	Voltage* V	Resistance kΩ
20 (68)	3.5	2.1 - 2.9
50 (122)	2.2	0.68 - 1.00
90 (194)	0.9	0.236 - 0.260

*: These data are reference values and are measured between ECM terminal 73 (Engine coolant temperature sensor) and ground.

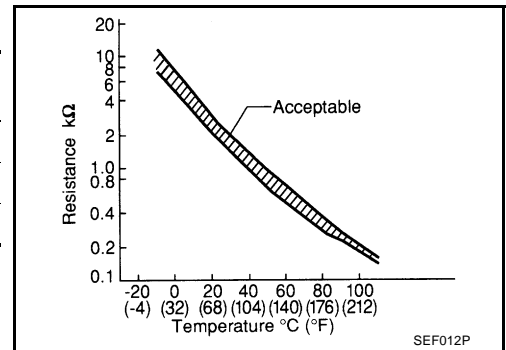

CAUTION:

Do not use ECM ground terminals when measuring input/output voltage. Doing so may result in damage to the ECM's transistor. Use a ground other than ECM terminals, such as the ground.

On Board Diagnosis Logic

ABS00C1S

These self-diagnoses have the one trip detection logic.

DTC No.	Trouble Diagnosis Name	DTC Detecting Condition	Possible Cause
P0117 0117	Engine coolant temperature sensor circuit low input	An excessively low voltage from the sensor is sent to ECM.	<ul style="list-style-type: none"> ● Harness or connectors (The sensor circuit is open or shorted.) ● Engine coolant temperature sensor
P0118 0118	Engine coolant temperature sensor circuit high input	An excessively high voltage from the sensor is sent to ECM.	

FAIL-SAFE MODE

When the malfunction is detected, the ECM enters fail-safe mode and the MIL lights up.

Detected items	Engine operating condition in fail-safe mode	
Engine coolant temperature sensor circuit	Engine coolant temperature will be determined by ECM based on the time after turning ignition switch ON or START. CONSULT-II displays the engine coolant temperature decided by ECM.	
	Condition	Engine coolant temperature decided (CONSULT-II display)
	Just as ignition switch is turned ON or START	40°C (104°F)
	More than approx. 4 minutes after ignition ON or START	80°C (176°F)
	Except as shown above	40 - 80°C (104 - 176°F) (Depends on the time)
When the fail-safe system for engine coolant temperature sensor is activated, the cooling fan operates while engine is running.		

DTC Confirmation Procedure

NOTE:

If DTC Confirmation Procedure has been previously conducted, always turn ignition switch OFF and wait at least 10 seconds before conducting the next test.

Ⓟ WITH CONSULT-II

1. Turn ignition switch ON.
2. Select "DATA MONITOR" mode with CONSULT-II.
3. Wait at least 5 seconds.
4. If DTC is detected, go to [EC-845, "Diagnostic Procedure"](#) .

DATA MONITOR	
MONITOR	NO DTC
ENG SPEED	XXX rpm

SEF058Y

Ⓢ WITH GST

Follow the procedure "WITH CONSULT-II" above.

A
EC
C
D
E
F
G
H
I
J
K
L
M

DTC P0117, P0118 ECT SENSOR

[VK45DE]

Wiring Diagram

ABS00C1U

EC-ECTS-01

: DETECTABLE LINE FOR DTC
 : NON-DETECTABLE LINE FOR DTC

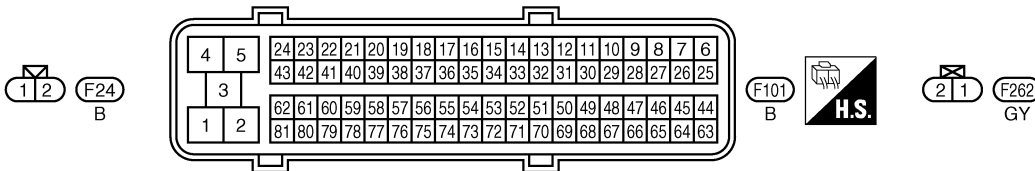
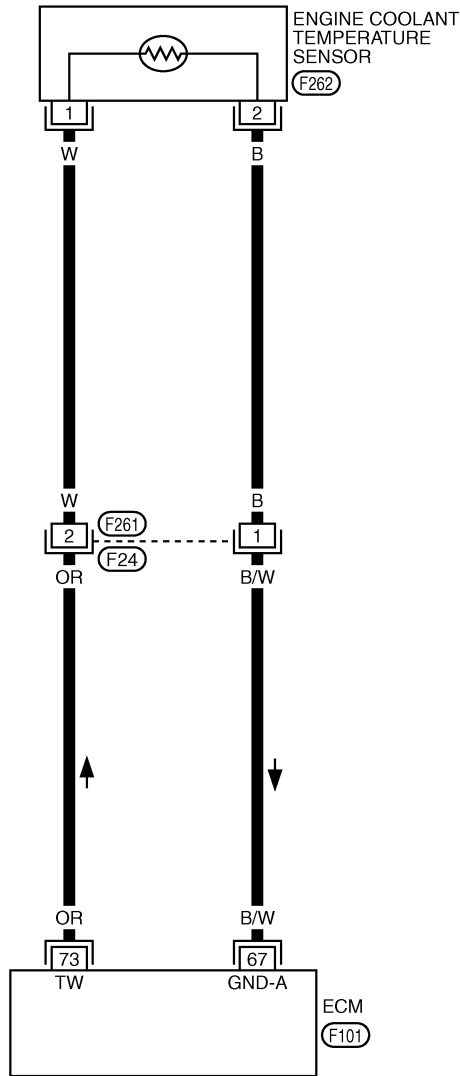

TBWM0227E

Diagnostic Procedure

1. CHECK GROUND CONNECTIONS

1. Turn ignition switch OFF.
2. Loosen and retighten three ground screws on the body.
Refer to [EC-791, "Ground Inspection"](#).

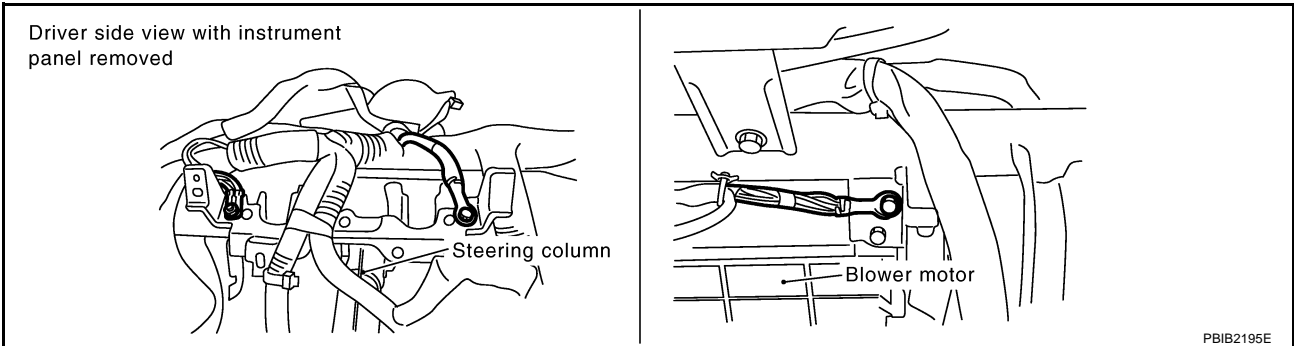

OK or NG

- OK >> GO TO 2.
- NG >> Repair or replace ground connections.

2. CHECK ECT SENSOR POWER SUPPLY CIRCUIT

1. Disconnect engine coolant temperature (ECT) sensor harness connector.

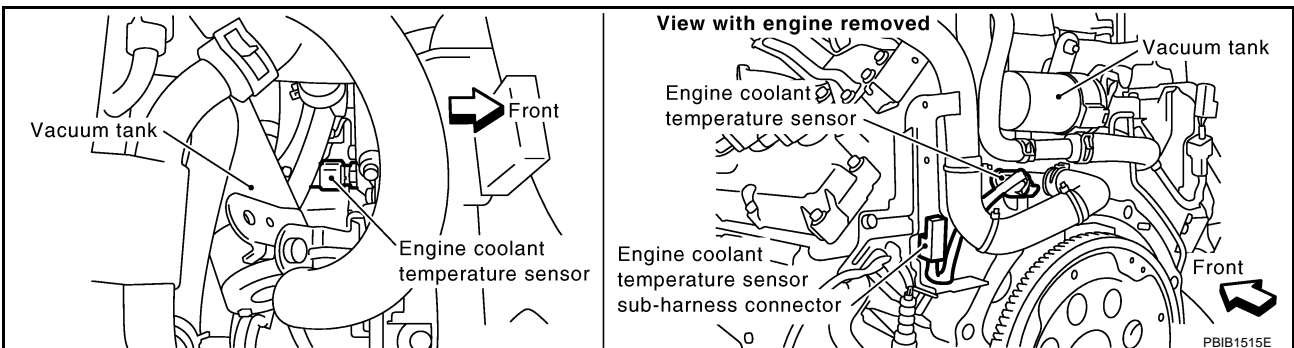

2. Turn ignition switch ON.
3. Check voltage between ECT sensor terminal 1 and ground with CONSULT-II or tester.

Voltage: Approximately 5V

OK or NG

- OK >> GO TO 4.
- NG >> GO TO 3.

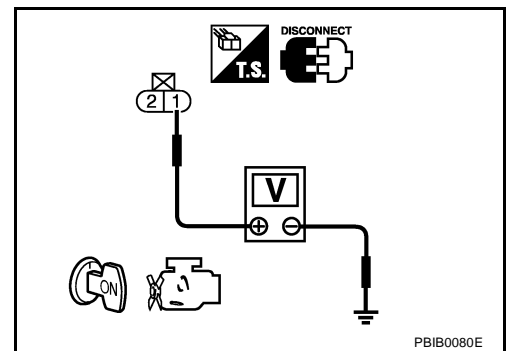

3. DETECT MALFUNCTIONING PART

Check the following.

- Harness connector F261, F24
- Harness for open or short between engine coolant temperature sensor and ECM

>> Repair open circuit or short to ground or short to power in harness or connectors.

4. CHECK ECT SENSOR GROUND CIRCUIT FOR OPEN AND SHORT

1. Turn ignition switch OFF.
2. Disconnect ECM harness connector.
3. Check harness continuity between ECT sensor terminal 2 and ECM terminal 67.
Refer to Wiring Diagram.

Continuity should exist.

4. Also check harness for short to ground and short to power.

OK or NG

- OK >> GO TO 6.
NG >> GO TO 5.

5. DETECT MALFUNCTIONING PART

Check the following.

- Harness connector F261, F24
- Harness for open and short between engine coolant temperature sensor and ECM

>> Repair open circuit or short to ground or short to power in harness or connectors.

6. CHECK ENGINE COOLANT TEMPERATURE SENSOR

Refer to [EC-846, "Component Inspection"](#) .

OK or NG

- OK >> GO TO 7.
NG >> Replace engine coolant temperature sensor.

7. CHECK INTERMITTENT INCIDENT

Refer to [EC-784, "TROUBLE DIAGNOSIS FOR INTERMITTENT INCIDENT"](#) .

>> INSPECTION END

Component Inspection ENGINE COOLANT TEMPERATURE SENSOR

1. Check resistance between engine coolant temperature sensor terminals 1 and 2 as shown in the figure.

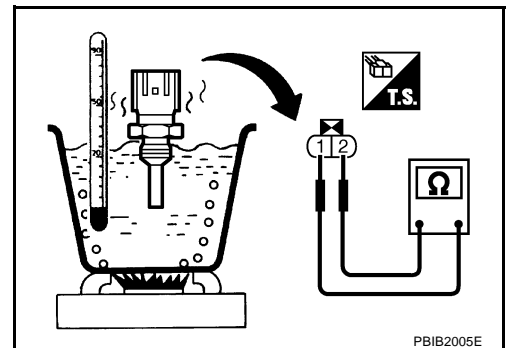

DTC P0117, P0118 ECT SENSOR

[VK45DE]

<Reference data>

Engine coolant temperature °C (°F)	Voltage* V	Resistance kΩ
20 (68)	3.5	2.1 - 2.9
50 (122)	2.2	0.68 - 1.00
90 (194)	0.9	0.236 - 0.260

*: These data are reference values and are measured between ECM terminal 73 (Engine coolant temperature sensor) and ground.

- If NG, replace engine coolant temperature sensor.

Removal and Installation ENGINE COOLANT TEMPERATURE SENSOR

Refer to [EM-224, "CYLINDER HEAD"](#) .

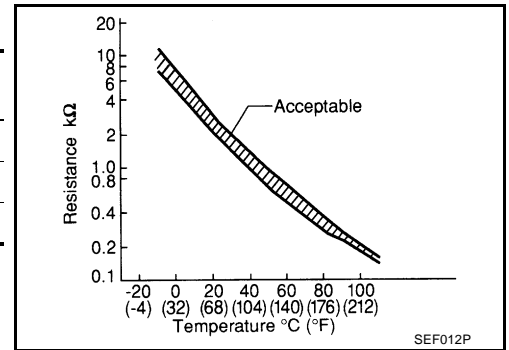

ABS00C1X

A
EC
C
D
E
F
G
H
I
J
K
L
M

DTC P0122, P0123 TP SENSOR

PF16119

Component Description

ABS00C1Y

Electric throttle control actuator consists of throttle control motor, throttle position sensor, etc. The throttle position sensor responds to the throttle valve movement.

The throttle position sensor has the two sensors. These sensors are a kind of potentiometers which transform the throttle valve position into output voltage, and emit the voltage signal to the ECM. In addition, these sensors detect the opening and closing speed of the throttle valve and feed the voltage signals to the ECM. The ECM judges the current opening angle of the throttle valve from these signals and the ECM controls the throttle control motor to make the throttle valve opening angle properly in response to driving condition.

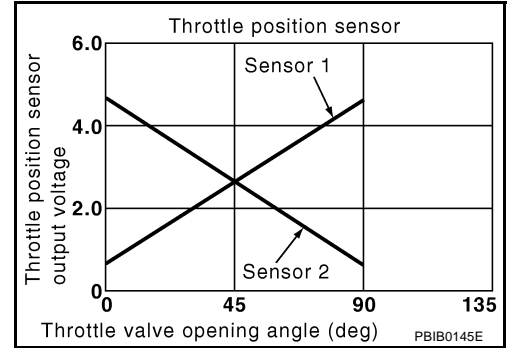

CONSULT-II Reference Value in Data Monitor Mode

ABS00C1Z

Specification data are reference values.

MONITOR ITEM	CONDITION		SPECIFICATION
THRTL SEN1 THRTL SEN2*	<ul style="list-style-type: none"> Ignition switch: ON (Engine stopped) Shift lever: D 	Accelerator pedal: Fully released	More than 0.36V
		Accelerator pedal: Fully depressed	Less than 4.75V

*: Throttle position sensor 2 signal is converted by ECM internally. Thus, it differs from ECM terminal voltage signal.

On Board Diagnosis Logic

ABS00C20

These self-diagnoses have the one trip detection logic.

DTC No.	Trouble diagnosis name	DTC detecting condition	Possible cause
P0122 0122	Throttle position sensor 2 circuit low input	An excessively low voltage from the TP sensor 2 is sent to ECM.	<ul style="list-style-type: none"> Harness or connectors (TP sensor 2 circuit is open or shorted.) (APP sensor 2 circuit is shorted.) Electric throttle control actuator (TP sensor 2) Accelerator pedal position sensor
P0123 0123	Throttle position sensor 2 circuit high input	An excessively high voltage from the TP sensor 2 is sent to ECM.	

FAIL-SAFE MODE

When the malfunction is detected, ECM enters fail-safe mode and the MIL lights up.

Engine operation condition in fail-safe mode

The ECM controls the electric throttle control actuator in regulating the throttle opening in order for the idle position to be within +10 degrees.

The ECM regulates the opening speed of the throttle valve to be slower than the normal condition.

So, the acceleration will be poor.

DTC Confirmation Procedure**NOTE:**

If DTC Confirmation Procedure has been previously conducted, always turn ignition switch OFF and wait at least 10 seconds before conducting the next test.

TESTING CONDITION:

Before performing the following procedure, confirm that battery voltage is more than 10V at idle.

 **WITH CONSULT-II**

1. Turn ignition switch ON.
2. Select "DATA MONITOR" mode with CONSULT-II.
3. Start engine and let it idle for 1 second.
4. If DTC is detected, go to [EC-851, "Diagnostic Procedure"](#) .

DATA MONITOR	
MONITOR	NO DTC
ENG SPEED	XXX rpm

SEF058Y

 **WITH GST**

Follow the procedure "WITH CONSULT-II" above.

A

EC

C

D

E

F

G

H

I

J

K

L

M

DTC P0122, P0123 TP SENSOR

[VK45DE]

ABS00C22

Wiring Diagram

EC-TPS2-01

: DETECTABLE LINE FOR DTC
 : NON-DETECTABLE LINE FOR DTC

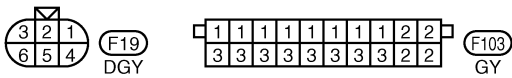
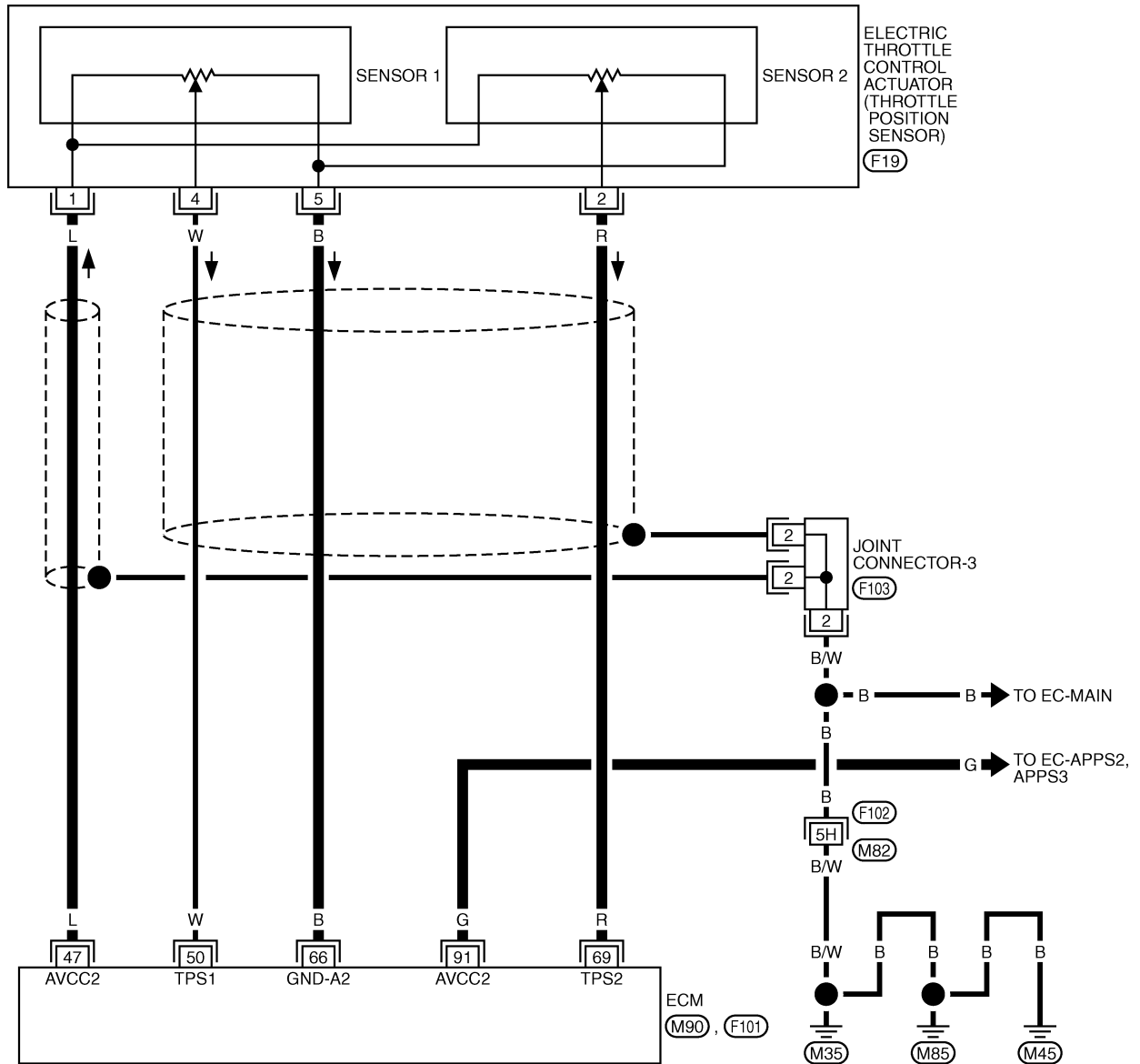

REFER TO THE FOLLOWING.

(F102) -SUPER MULTIPLE JUNCTION (SMJ)

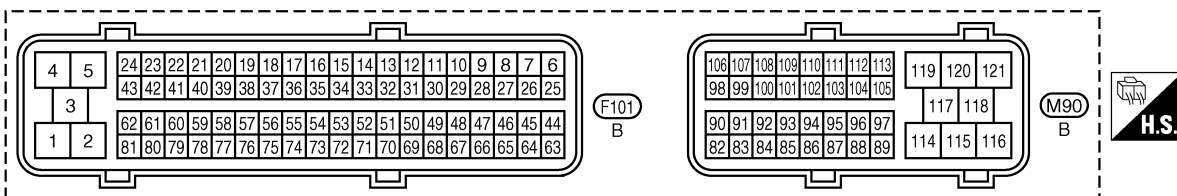

TBWM0429E

DTC P0122, P0123 TP SENSOR

[VK45DE]

Specification data are reference values and are measured between each terminal and ground.

CAUTION:

Do not use ECM ground terminals when measuring input/output voltage. Doing so may result in damage to the ECM's transistor. Use a ground other than ECM terminals, such as the ground.

TER-MINAL NO.	WIRE COLOR	ITEM	CONDITION	DATA (DC Voltage)
47	L	Sensor power supply (Throttle position sensor)	[Ignition switch: ON]	Approximately 5V
50	W	Throttle position sensor 1	[Ignition switch: ON] <ul style="list-style-type: none"> ● Engine stopped ● Shift lever: D ● Accelerator pedal is fully released 	More than 0.36V
			[Ignition switch: ON] <ul style="list-style-type: none"> ● Engine stopped ● Shift lever: D ● Accelerator pedal is fully depressed 	Less than 4.75V
66	B	Sensor ground (Throttle position sensor)	[Engine is running] <ul style="list-style-type: none"> ● Warm-up condition ● Idle speed 	Approximately 0V
69	R	Throttle position sensor 2	[Ignition switch: ON] <ul style="list-style-type: none"> ● Engine stopped ● Shift lever: D ● Accelerator pedal is fully released 	Less than 4.75V
			[Ignition switch: ON] <ul style="list-style-type: none"> ● Engine stopped ● Shift lever: D ● Accelerator pedal is fully depressed 	More than 0.36V
91	G	Sensor power supply (APP sensor 2)	[Ignition switch: ON]	Approximately 5V

Diagnostic Procedure

ABS00C23

1. CHECK GROUND CONNECTIONS

1. Turn ignition switch OFF.
2. Loosen and retighten three ground screws on the body.
Refer to [EC-791, "Ground Inspection"](#) .

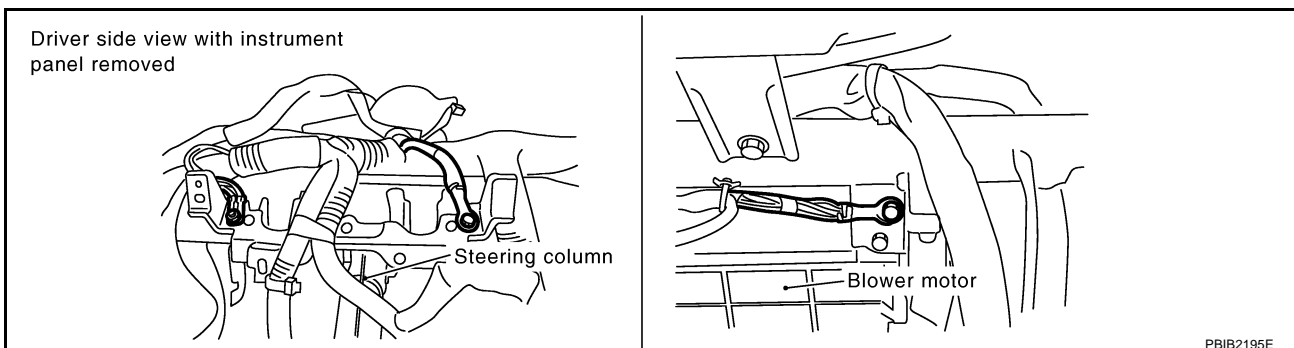

PBIB2195E

OK or NG

- OK >> GO TO 2.
- NG >> Repair or replace ground connections.

2. CHECK THROTTLE POSITION SENSOR 2 POWER SUPPLY CIRCUIT-I

1. Disconnect electric throttle control actuator harness connector.
2. Turn ignition switch ON.

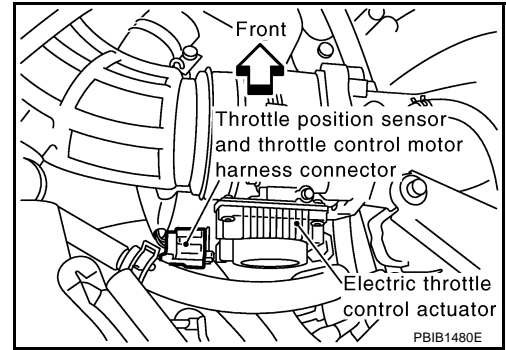

3. Check voltage between electric throttle control actuator terminal 1 and ground with CONSULT-II or tester.

Voltage: Approximately 5V

OK or NG

- OK >> GO TO 7.
 NG >> GO TO 3.

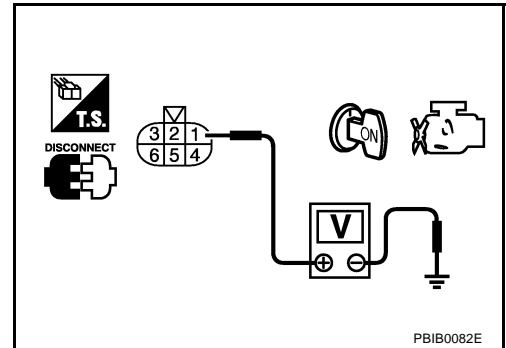

3. CHECK THROTTLE POSITION SENSOR 2 POWER SUPPLY CIRCUIT-II

1. Turn ignition switch OFF.
2. Disconnect ECM harness connector.
3. Check harness continuity between electric throttle control actuator terminal 1 and ECM terminal 47. Refer to Wiring Diagram.

Continuity should exist.

OK or NG

- OK >> GO TO 4.
 NG >> Repair or replace open circuit.

4. CHECK THROTTLE POSITION SENSOR 2 POWER SUPPLY CIRCUIT-III

Check harness for short to power and short to ground, between the following terminals.

ECM terminal	Sensor terminal	Reference Wiring Diagram
47	Electric throttle control actuator terminal 1	EC-850
91	APP sensor terminal 4	EC-1234

OK or NG

- OK >> GO TO 5.
 NG >> Repair short to ground or short to power in harness or connectors.

5. CHECK APP SENSOR

Refer to [EC-1238, "Component Inspection"](#).

OK or NG

- OK >> GO TO 11.
 NG >> GO TO 6.

6. REPLACE ACCELERATOR PEDAL ASSEMBLY

1. Replace accelerator pedal assembly.
2. Perform [EC-698, "Accelerator Pedal Released Position Learning"](#) .
3. Perform [EC-698, "Throttle Valve Closed Position Learning"](#) .
4. Perform [EC-698, "Idle Air Volume Learning"](#) .

>> INSPECTION END

7. CHECK THROTTLE POSITION SENSOR 2 GROUND CIRCUIT FOR OPEN AND SHORT

1. Turn ignition switch OFF.
2. Disconnect ECM harness connector.
3. Check harness continuity between electric throttle control actuator terminal 5 and ECM terminal 66.
Refer to Wiring Diagram.

Continuity should exist.

4. Also check harness for short to ground and short to power.

OK or NG

OK >> GO TO 8.

NG >> Repair open circuit or short to ground or short to power in harness or connectors.

8. CHECK THROTTLE POSITION SENSOR 2 INPUT SIGNAL CIRCUIT FOR OPEN AND SHORT

1. Check harness continuity between electric throttle control actuator terminal 2 and ECM terminal 69.
Refer to Wiring Diagram.

Continuity should exist.

2. Also check harness for short to ground and short to power.

OK or NG

OK >> GO TO 9.

NG >> Repair open circuit or short to ground or short to power in harness or connectors.

9. CHECK THROTTLE POSITION SENSOR

Refer to [EC-854, "Component Inspection"](#) .

OK or NG

OK >> GO TO 11.

NG >> GO TO 10.

10. REPLACE ELECTRIC THROTTLE CONTROL ACTUATOR

1. Replace the electric throttle control actuator.
2. Perform [EC-698, "Throttle Valve Closed Position Learning"](#) .
3. Perform [EC-698, "Idle Air Volume Learning"](#) .

>> INSPECTION END

11. CHECK INTERMITTENT INCIDENT

Refer to [EC-784, "TROUBLE DIAGNOSIS FOR INTERMITTENT INCIDENT"](#) .

>> INSPECTION END

Component Inspection
THROTTLE POSITION SENSOR

1. Reconnect all harness connectors disconnected.
2. Perform [EC-698, "Throttle Valve Closed Position Learning"](#) .
3. Turn ignition switch ON.
4. Set selector lever to D position.
5. Check voltage between ECM terminals 50 (TP sensor 1signal), 69 (TP sensor 2signal) and ground under the following conditions.

Terminal	Accelerator pedal	Voltage
50 (Throttle position sensor 1)	Fully released	More than 0.36V
	Fully depressed	Less than 4.75V
69 (Throttle position sensor 2)	Fully released	Less than 4.75V
	Fully depressed	More than 0.36V

6. If NG, replace electric throttle control actuator and go to the next step.
7. Perform [EC-698, "Throttle Valve Closed Position Learning"](#) .
8. Perform [EC-698, "Idle Air Volume Learning"](#) .

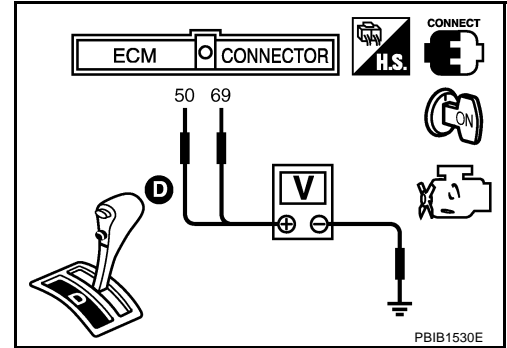

PBIB1530E

Removal and Installation
ELECTRIC THROTTLE CONTROL ACTUATOR

Refer to [EM-174, "INTAKE MANIFOLD"](#) .

DTC P0125 ECT SENSOR

PFP:22630

Component Description

ABS00C26

NOTE:

If DTC P0125 is displayed with P0117 or P0118, first perform the trouble diagnosis for DTC P0117 or P0118. Refer to [EC-842](#).

The engine coolant temperature sensor is used to detect the engine coolant temperature. The sensor modifies a voltage signal from the ECM. The modified signal returns to the ECM as the engine coolant temperature input. The sensor uses a thermistor which is sensitive to the change in temperature. The electrical resistance of the thermistor decreases as temperature increases.

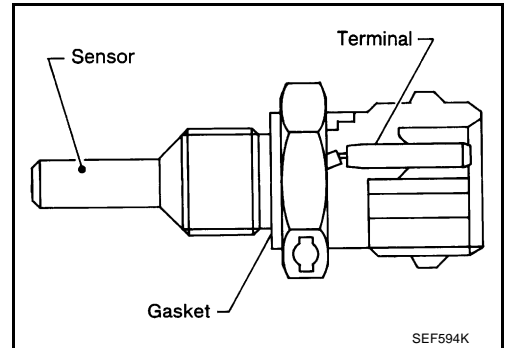

<Reference data>

Engine coolant temperature °C (°F)	Voltage* V	Resistance kΩ
-10 (14)	4.4	7.0 - 11.4
20 (68)	3.5	2.1 - 2.9
50 (122)	2.2	0.68 - 1.00
90 (194)	0.9	0.236 - 0.260

*: These data are reference values and are measured between ECM terminal 73 (Engine coolant temperature sensor) and ground.

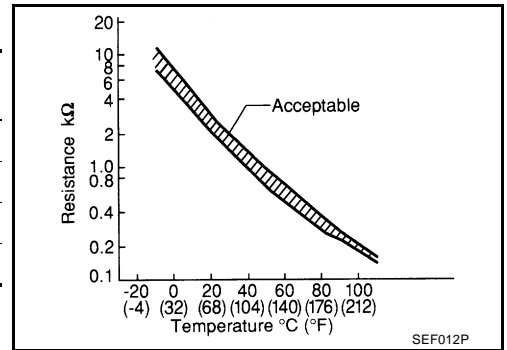

CAUTION:

Do not use ECM ground terminals when measuring input/output voltage. Doing so may result in damage to the ECM's transistor. Use a ground other than ECM terminals, such as the ground.

On Board Diagnosis Logic

ABS00C27

This self-diagnosis has the one trip detection logic.

DTC No.	Trouble diagnosis name	DTC detecting condition	Possible cause
P0125 0125	Insufficient engine coolant temperature for closed loop fuel control	<ul style="list-style-type: none"> ● Voltage sent to ECM from the sensor is not practical, even when some time has passed after starting the engine. ● Engine coolant temperature is insufficient for closed loop fuel control. 	<ul style="list-style-type: none"> ● Harness or connectors (High resistance in the circuit) ● Engine coolant temperature sensor ● Thermostat

DTC Confirmation Procedure

CAUTION:

Be careful not to overheat engine.

NOTE:

If DTC Confirmation Procedure has been previously conducted, always turn ignition switch OFF and wait at least 10 seconds before conducting the next test.

WITH CONSULT-II

1. Turn ignition switch ON.
2. Select "DATA MONITOR" mode with CONSULT-II.
3. Check that "COOLAN TEMP/S" is above 10°C (50°F).
If it is above 10°C (50°F), the test result will be OK.
If it is below 10°C (50°F), go to following step.
4. Start engine and run it for 65 minutes at idle speed.
If "COOLAN TEMP/S" increases to more than 10°C (50°F) within 65 minutes, stop engine because the test result will be OK.
5. If DTC is detected, go to [EC-856, "Diagnostic Procedure"](#).

DATA MONITOR	
MONITOR	NO DTC
ENG SPEED	XXX rpm
COOLAN TEMP/S	XXX °C

SEF174Y

WITH GST

Follow the procedure "WITH CONSULT-II" above.

Diagnostic Procedure

1. CHECK GROUND CONNECTIONS

1. Turn ignition switch OFF.
2. Loosen and retighten three ground screws on the body.
Refer to [EC-791, "Ground Inspection"](#).

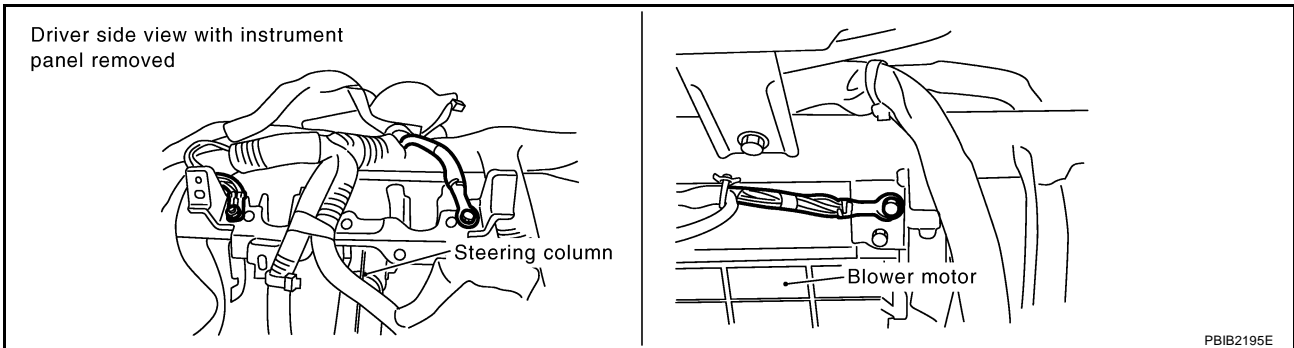

OK or NG

- OK >> GO TO 2.
- NG >> Repair or replace ground connections.

2. CHECK ENGINE COOLANT TEMPERATURE SENSOR

Refer to [EC-857, "Component Inspection"](#).

OK or NG

- OK >> GO TO 3.
- NG >> Replace engine coolant temperature sensor.

3. CHECK THERMOSTAT OPERATION

When the engine is cold [lower than 70°C (158°F)] condition, grasp lower radiator hose and confirm the engine coolant does not flow.

OK or NG

OK >> GO TO 4.

NG >> Repair or replace thermostat. Refer to [CO-51, "THERMOSTAT AND WATER CONTROL VALVE"](#).

4. CHECK INTERMITTENT INCIDENT

Refer to [EC-784, "TROUBLE DIAGNOSIS FOR INTERMITTENT INCIDENT"](#).

>> INSPECTION END

Component Inspection ENGINE COOLANT TEMPERATURE SENSOR

ABS00C2A

1. Check resistance between engine coolant temperature sensor terminals 1 and 2 as shown in the figure.

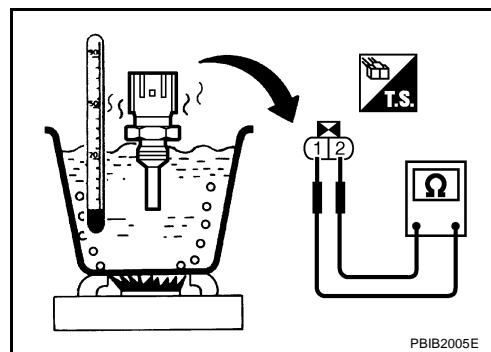

<Reference data>

Engine coolant temperature °C (°F)	Voltage* V	Resistance kΩ
20 (68)	3.5	2.1 - 2.9
50 (122)	2.2	0.68 - 1.00
90 (194)	0.9	0.236 - 0.260

*: These data are reference values and are measured between ECM terminal 73 (Engine coolant temperature sensor) and ground.

2. If NG, replace engine coolant temperature sensor.

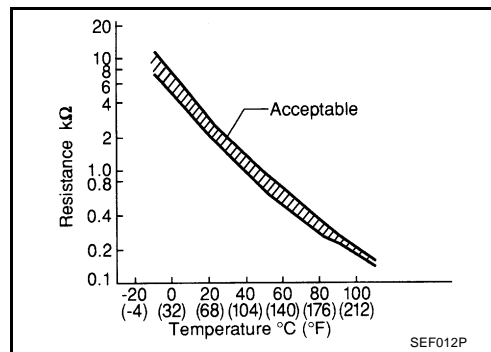

Removal and Installation ENGINE COOLANT TEMPERATURE SENSOR

ABS00C2B

Refer to [CO-51, "THERMOSTAT AND WATER CONTROL VALVE"](#).

DTC P0127 IAT SENSOR

PFP:22630

Component Description

ABS00C2C

The intake air temperature sensor is built into mass air flow sensor. The sensor detects intake air temperature and transmits a signal to the ECM.

The temperature sensing unit uses a thermistor which is sensitive to the change in temperature. Electrical resistance of the thermistor decreases in response to the temperature rise.

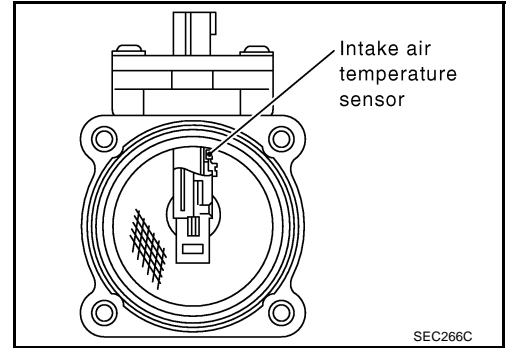

<Reference data>

Intake air temperature °C (°F)	Voltage* V	Resistance kΩ
-10 (14)	4.43	7.9 - 9.3
25 (77)	3.32	1.9 - 2.1
80 (176)	1.23	0.31 - 0.37

*: These data are reference values and are measured between ECM terminal 34 (Intake air temperature sensor) and ground.

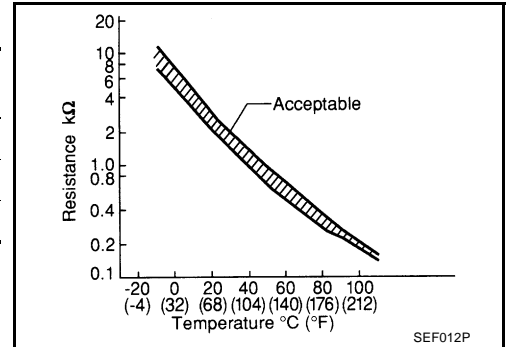

CAUTION:

Do not use ECM ground terminals when measuring input/output voltage. Doing so may result in damage to the ECM's transistor. Use a ground other than ECM terminals, such as the ground.

On Board Diagnosis Logic

ABS00C2D

DTC No.	Trouble diagnosis name	DTC detecting condition	Possible cause
P0127 0127	Intake air temperature too high	Rationally incorrect voltage from the sensor is sent to ECM, compared with the voltage signal from engine coolant temperature sensor.	<ul style="list-style-type: none"> ● Harness or connectors (The sensor circuit is open or shorted) ● Intake air temperature sensor

DTC Confirmation Procedure

ABS00C2E

NOTE:

If DTC Confirmation Procedure has been previously conducted, always turn ignition switch OFF and wait at least 10 seconds before conducting the next test.

CAUTION:

Always drive vehicle at a safe speed.

TESTING CONDITION:

This test may be conducted with the drive wheels lifted in the shop or by driving the vehicle. If a road test is expected to be easier, it is unnecessary to lift the vehicle.

Ⓟ WITH CONSULT-II

1. Wait until engine coolant temperature is less than 90°C (194°F)
 - a. Turn ignition switch ON.

- b. Select "DATA MONITOR" mode with CONSULT-II.
- c. Check the engine coolant temperature.
- d. If the engine coolant temperature is not less than 90°C (194°F), turn ignition switch OFF and cool down engine.
 - Perform the following steps before engine coolant temperature is above 90°C (194°F).
2. Turn ignition switch ON.
3. Select "DATA MONITOR" mode with CONSULT-II.
4. Start engine.
5. Hold vehicle speed at more than 70 km/h (43 MPH) for 100 consecutive seconds.
6. If 1st trip DTC is detected, go to [EC-859, "Diagnostic Procedure"](#).

DATA MONITOR	
MONITOR	NO DTC
ENG SPEED	XXX rpm
COOLAN TEMP/S	XXX °C
VHCL SPEED SE	XXX km/h
B/FUEL SCHDL	XXX msec

SEF189Y

WITH GST

Follow the procedure "WITH CONSULT-II" above.

Diagnostic Procedure

ABS00C2F

1. CHECK GROUND CONNECTIONS

1. Turn ignition switch OFF.
2. Loosen and retighten three ground screws on the body.
Refer to [EC-791, "Ground Inspection"](#).

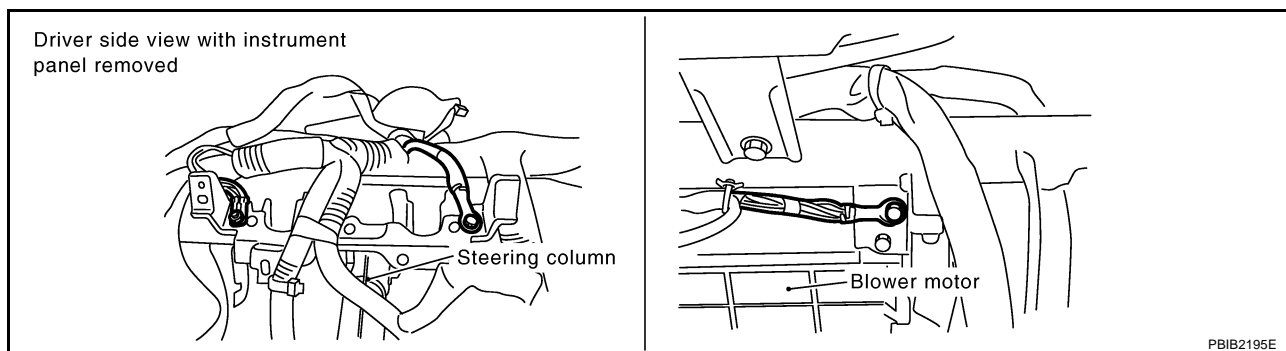

OK or NG

- OK >> GO TO 2.
- NG >> Repair or replace ground connections.

2. CHECK INTAKE AIR TEMPERATURE SENSOR

Refer to [EC-841, "Component Inspection"](#).

OK or NG

- OK >> GO TO 3.
- NG >> Replace mass air flow sensor (with intake air temperature sensor).

3. CHECK INTERMITTENT INCIDENT

Refer to [EC-784, "TROUBLE DIAGNOSIS FOR INTERMITTENT INCIDENT"](#).

>> **INSPECTION END**

Component Inspection INTAKE AIR TEMPERATURE SENSOR

1. Check resistance between intake air temperature sensor terminals 5 and 6 under the following conditions.

Intake air temperature °C (°F)	Resistance kΩ
25 (77)	1.9 - 2.1

2. If NG, replace mass air flow sensor (with intake air temperature sensor).

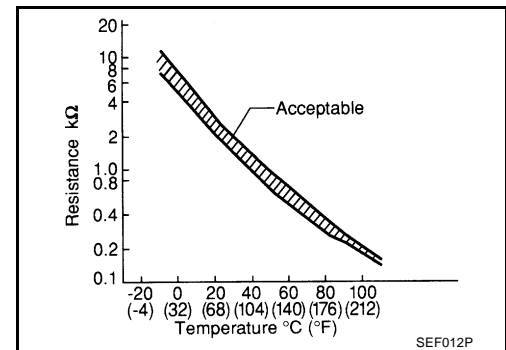
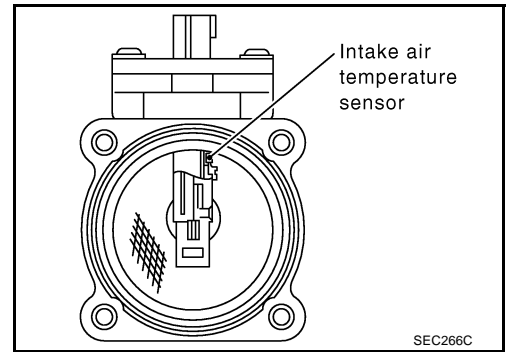

SEC266C

SEF012P

Removal and Installation MASS AIR FLOW SENSOR

Refer to [EM-172, "AIR CLEANER AND AIR DUCT"](#) .

DTC P0128 THERMOSTAT FUNCTION

PFP:21200

On Board Diagnosis Logic

ABS00C2I

Engine coolant temperature has not risen enough to open the thermostat even though the engine has run long enough.

This is due to a leak in the seal or the thermostat stuck open.

DTC No.	Trouble diagnosis name	DTC detecting condition	Possible cause
P0128 0128	Thermostat function	The engine coolant temperature does not reach to specified temperature even though the engine has run long enough.	<ul style="list-style-type: none"> ● Thermostat ● Leakage from sealing portion of thermostat ● Engine coolant temperature sensor

DTC Confirmation Procedure

ABS00C2J

NOTE:

If DTC Confirmation Procedure has been previously conducted, always turn ignition switch OFF and wait at least 10 seconds before conducting the next test.

TESTING CONDITION:

- For best results, perform at ambient temperature of -10°C (14°F) or higher.
- For best results, perform at engine coolant temperature of -10°C (14°F) to 60°C (140°F).

 **WITH CONSULT-II**

1. Replace thermostat with new one. Refer to [CO-51, "THERMOSTAT AND WATER CONTROL VALVE"](#) . Use only a genuine NISSAN thermostat as a replacement. If an incorrect thermostat is used, the MIL may come on.
2. Turn ignition switch ON.
3. Select "COOLAN TEMP/S" in "DATA MONITOR" mode with CONSULT-II.
4. Check that the "COOLAN TEMP/S" is above 60°C (140°F).
If it is below 60°C (140°F), go to following step.
If it is above 60°C (140°F), cool down the engine to less than 60°C (140°F), then retry from step 1.
5. Drive vehicle for 10 consecutive minutes under the following conditions.

VHCL SPEED SE	80 - 120 km/h (50 - 75 MPH)
---------------	-----------------------------

If 1st trip DTC is detected, go to [EC-861, "Diagnostic Procedure"](#) .

 **WITH GST**

1. Follow the procedure "WITH CONSULT-II" above.

Diagnostic Procedure

ABS00C2K

1. CHECK ENGINE COOLANT TEMPERATURE SENSOR

Refer to [EC-862, "Component Inspection"](#) .

OK or NG

- OK >> **INSPECTION END**
- NG >> Replace engine coolant temperature sensor.

DTC P0128 THERMOSTAT FUNCTION

[VK45DE]

ABS00C2L

Component Inspection ENGINE COOLANT TEMPERATURE SENSOR

Check resistance as shown in the figure.

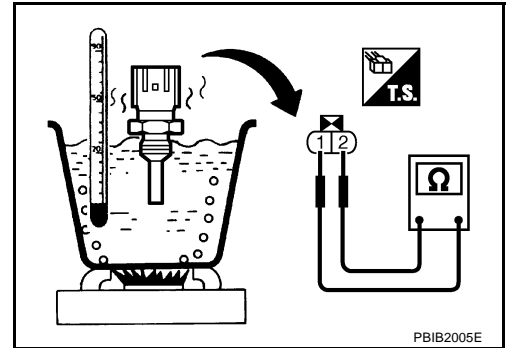

<Reference data>

Temperature °C (°F)	Resistance kΩ
20 (68)	2.1 - 2.9
50 (122)	0.68 - 1.0
90 (194)	0.236 - 0.260

If NG, replace engine coolant temperature sensor.

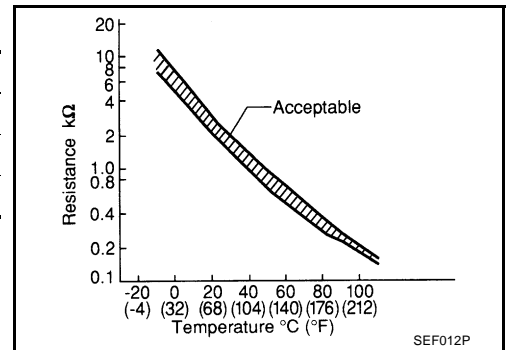

Removal and Installation ENGINE COOLANT TEMPERATURE SENSOR

Refer to [CO-51, "THERMOSTAT AND WATER CONTROL VALVE"](#).

ABS00C2M

DTC P0132, P0152 HO2S1

PFP:22690

Component Description

ABS00C2N

The heated oxygen sensor 1 is placed into the exhaust manifold. It detects the amount of oxygen in the exhaust gas compared to the outside air. The heated oxygen sensor 1 has a closed-end tube made of ceramic zirconia. The zirconia generates voltage from approximately 1V in richer conditions to 0V in leaner conditions. The heated oxygen sensor 1 signal is sent to the ECM. The ECM adjusts the injection pulse duration to achieve the ideal air-fuel ratio. The ideal air-fuel ratio occurs near the radical change from 1 to 0V.

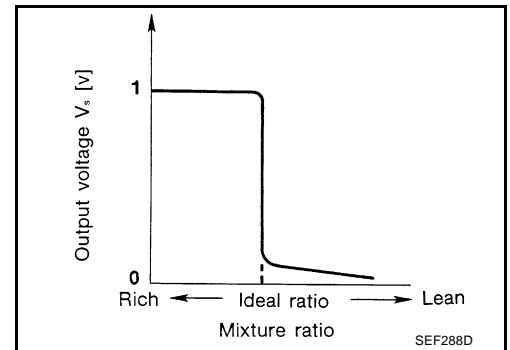
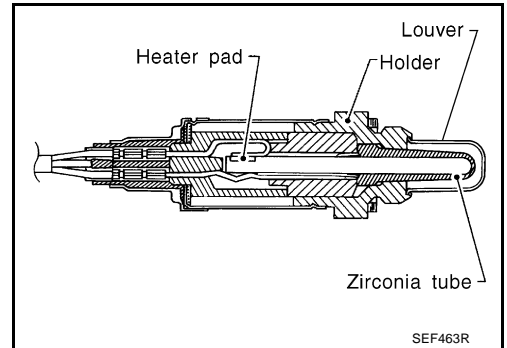

CONSULT-II Reference Value in Data Monitor Mode

ABS00C2O

Specification data are reference values.

MONITOR ITEM	CONDITION		SPECIFICATION
HO2S1 (B1) HO2S1 (B2)	● Engine: After warming up	Maintaining engine speed at 2,000 rpm	0 - 0.3V ↔ Approx. 0.6 - 1.0V
HO2S1 MNTR (B1) HO2S1 MNTR (B2)			LEAN ↔ RICH Changes more than 5 times during 10 seconds.

On Board Diagnosis Logic

ABS00C2P

To judge the malfunction, the diagnosis checks that the heated oxygen sensor 1 output is not inordinately high.

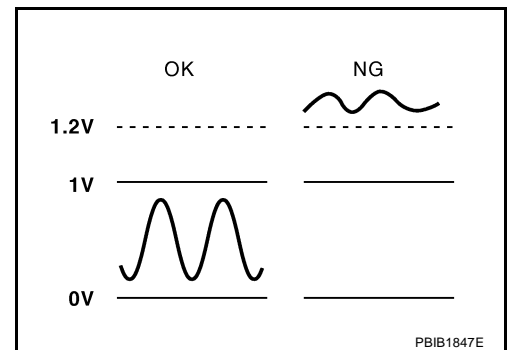

DTC No.	Trouble diagnosis name	DTC detecting condition	Possible cause
P0132 0132 (Bank 1)	Heated oxygen sensor 1 circuit high voltage	An excessively high voltage from the sensor is sent to ECM.	<ul style="list-style-type: none"> ● Harness or connectors (The sensor circuit is open or shorted) ● Heated oxygen sensor 1
P0152 0152 (Bank 2)			

DTC Confirmation Procedure**NOTE:**

If DTC Confirmation Procedure has been previously conducted, always turn ignition switch OFF and wait at least 10 seconds before conducting the next test.

④ WITH CONSULT-II

1. Start engine and warm it up to normal operating temperature.
2. Turn ignition switch OFF and wait at least 10 seconds.
3. Turn ignition switch ON.
4. Select "DATA MONITOR" mode with CONSULT-II.
5. Restart engine and let it idle for 2 minutes.
6. If 1st trip DTC is detected, go to [EC-868, "Diagnostic Procedure"](#)

DATA MONITOR	
MONITOR	NO DTC
ENG SPEED	XXX rpm
COOLAN TEMP/S	XXX °C

SEF174Y

④ WITH GST

Follow the procedure "WITH CONSULT-II" above.

Wiring Diagram
BANK 1

EC-O2S1B1-01

— : DETECTABLE LINE FOR DTC
— : NON-DETECTABLE LINE FOR DTC

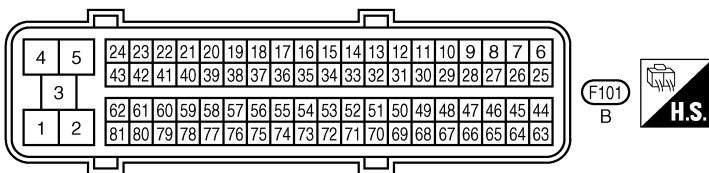
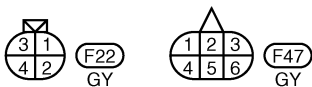
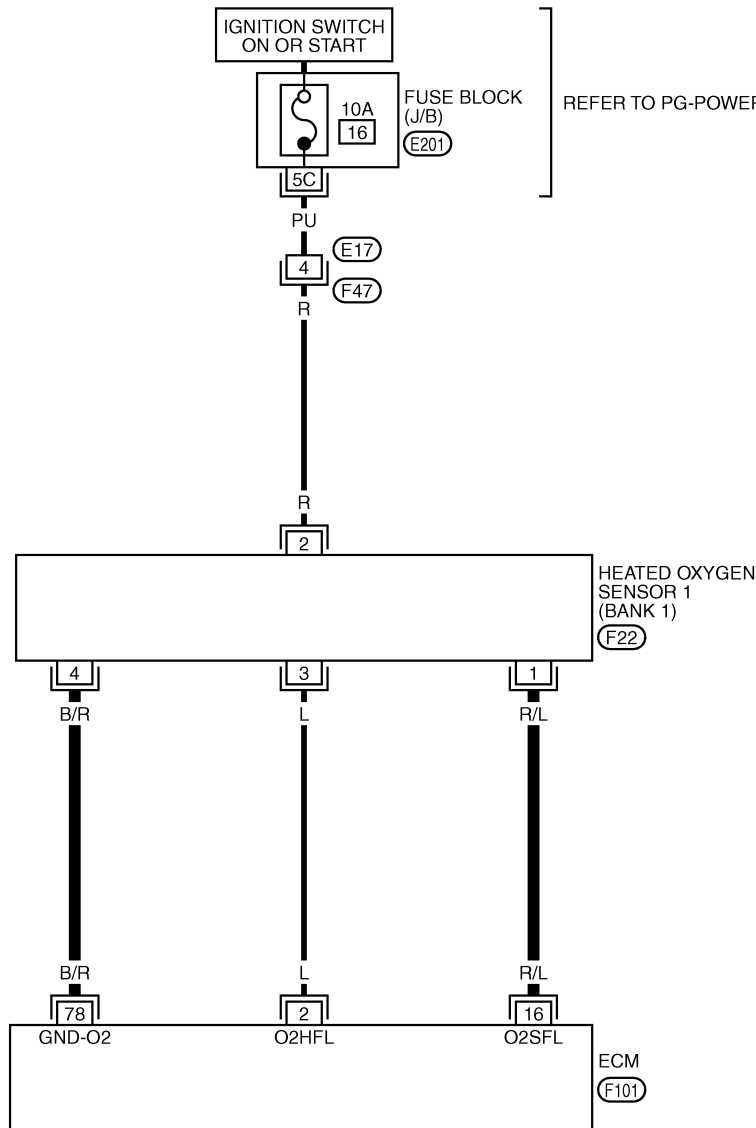

REFER TO THE FOLLOWING.
E201 - FUSE BLOCK-JUNCTION BOX (J/B)

DTC P0132, P0152 HO2S1

[VK45DE]

Specification data are reference values and are measured between each terminal and ground.

CAUTION:

Do not use ECM ground terminals when measuring input/output voltage. Doing so may result in damage to the ECM's transistor. Use a ground other than ECM terminals, such as the ground.

TER-MINAL NO.	WIRE COLOR	ITEM	CONDITION	DATA (DC Voltage)
16	R/L	Heated oxygen sensor 1 (bank 1)	[Engine is running] <ul style="list-style-type: none">● Warm-up condition● Engine speed is 2,000 rpm	0 - Approximately 1.0V (Periodically change)
78	B/R	Sensor ground (Heated oxygen sensor)	[Engine is running] <ul style="list-style-type: none">● Warm-up condition● Idle speed	Approximately 0V

BANK 2

EC-O2S1B2-01

— : DETECTABLE LINE FOR DTC
 — : NON-DETECTABLE LINE FOR DTC

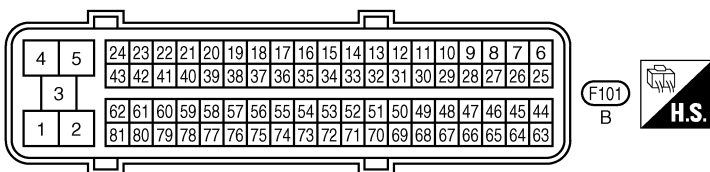
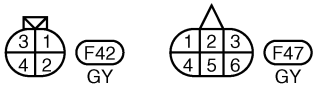
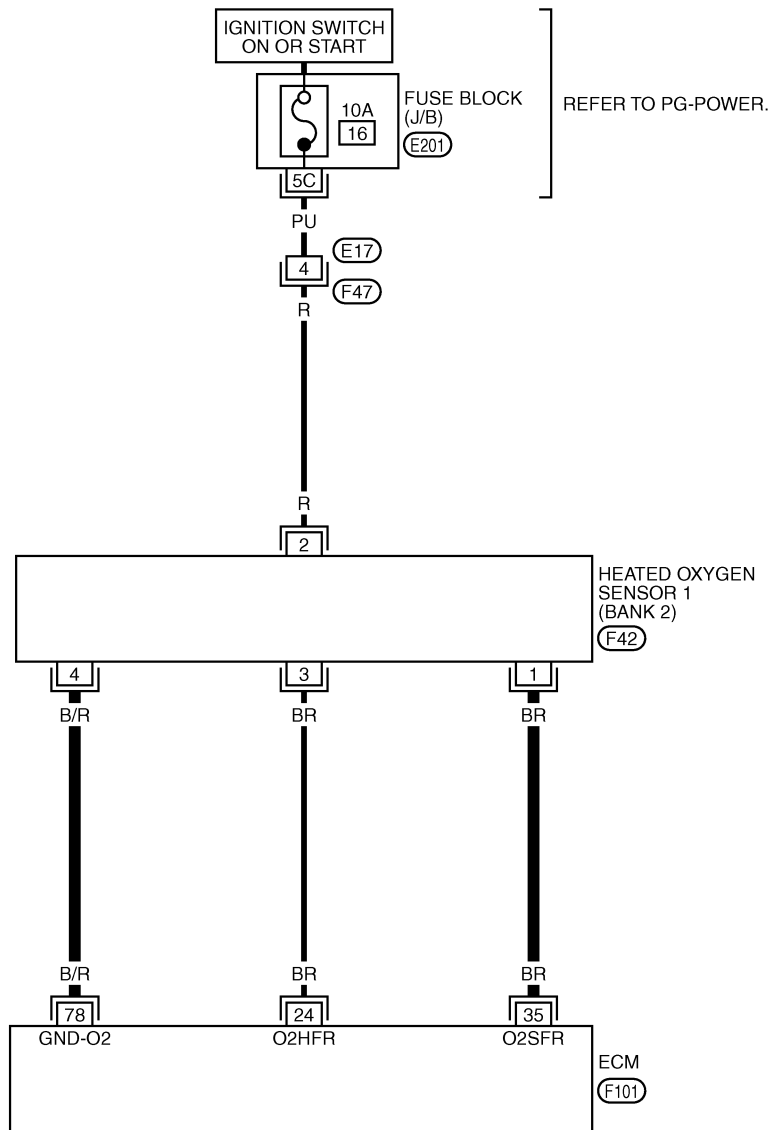

REFER TO THE FOLLOWING.
 E201 - FUSE BLOCK-JUNCTION BOX (J/B)

Specification data are reference values and are measured between each terminal and ground.

CAUTION:

Do not use ECM ground terminals when measuring input/output voltage. Doing so may result in damage to the ECM's transistor. Use a ground other than ECM terminals, such as the ground.

TER-MINAL NO.	WIRE COLOR	ITEM	CONDITION	DATA (DC Voltage)
35	BR	Heated oxygen sensor 1 (bank 2)	[Engine is running] ● Warm-up condition ● Engine speed is 2,000 rpm	0 - Approximately 1.0V (Periodically change)
78	B/R	Sensor ground (Heated oxygen sensor)	[Engine is running] ● Warm-up condition ● Idle speed	Approximately 0V

Diagnostic Procedure

ABS00C2S

1. CHECK GROUND CONNECTIONS

1. Turn ignition switch OFF.
2. Loosen and retighten three ground screws on the body.
Refer to [EC-791, "Ground Inspection"](#).

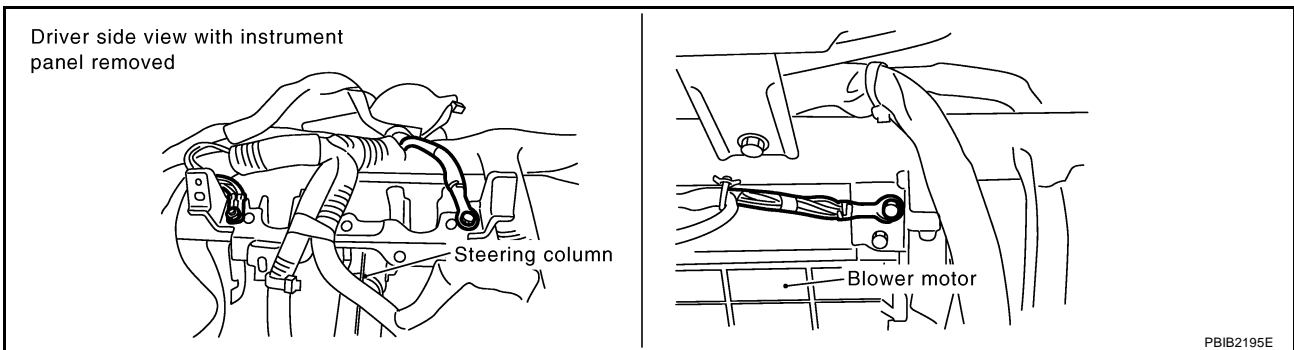

OK or NG

- OK >> GO TO 2.
- NG >> Repair or replace ground connections.

2. RETIGHTEN HEATED OXYGEN SENSOR 1

1. Loosen and retighten corresponding heated oxygen sensor 1.

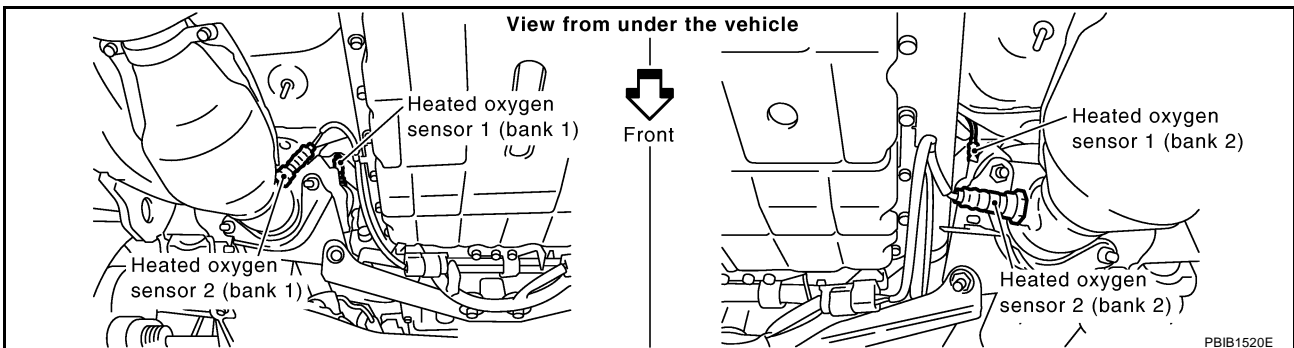

Tightening torque: 50 N·m (5.1 kg·m, 37 ft·lb)

>> GO TO 3.

3. CHECK HO2S1 GROUND CIRCUIT FOR OPEN AND SHORT

1. Disconnect heated oxygen sensor 1 harness connector.

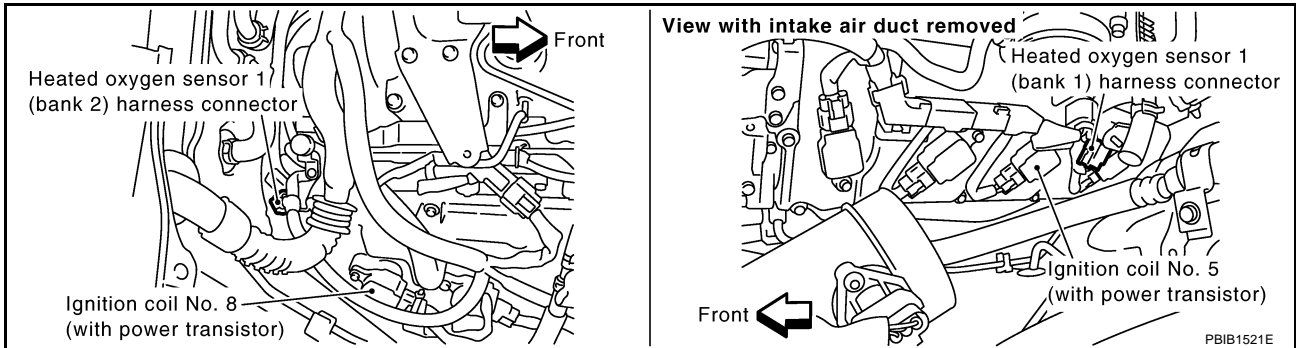

2. Disconnect ECM harness connector.
3. Check harness continuity between HO2S1 terminal 4 and ECM terminal 78.
Refer to Wiring Diagram.

Continuity should exist.

4. Also check harness for short to ground and short to power.

OK or NG

OK >> GO TO 4.

NG >> Repair open circuit or short to ground or short to power in harness or connectors.

4. CHECK HO2S1 INPUT SIGNAL CIRCUIT FOR OPEN AND SHORT

1. Check harness continuity between ECM terminal and HO2S1 terminal as follows.
Refer to Wiring Diagram.

DTC	Terminals		Bank
	ECM	Sensor	
P0132	16	1	1
P0152	35	1	2

Continuity should exist.

2. Check harness continuity between the following terminals and ground.
Refer to Wiring Diagram.

DTC	Terminals		Bank
	ECM	Sensor	
P0132	16	1	1
P0152	35	1	2

Continuity should not exist.

3. Also check harness for short to ground and short to power.

OK or NG

OK >> GO TO 5.

NG >> Repair open circuit or short to ground or short to power in harness or connectors.

5. CHECK HO2S1 CONNECTOR FOR WATER

1. Turn ignition switch OFF.
2. Disconnect heated oxygen sensor 1 harness connector.
3. Check connectors for water.

Water should not exist.

OK or NG

- OK >> GO TO 6.
 NG >> Repair or replace harness or connectors.

6. CHECK HEATED OXYGEN SENSOR 1

Refer to [EC-870, "Component Inspection"](#) .

OK or NG

- OK >> GO TO 7.
 NG >> Replace malfunctioning heated oxygen sensor 1.

7. CHECK INTERMITTENT INCIDENT

Refer to [EC-784, "TROUBLE DIAGNOSIS FOR INTERMITTENT INCIDENT"](#) .

>> INSPECTION END

Component Inspection HEATED OXYGEN SENSOR 1

ABS00C2T

With CONSULT-II

1. Start engine and warm it up to normal operating temperature.
2. Select "MANU TRIG" and adjust "TRIGGER POINT" to 100% in "DATA MONITOR" mode with CONSULT-II.
3. Select "HO2S1 (B1)/(B2)" and "HO2S1 MNTR (B1)/(B2)".
4. Hold engine speed at 2,000 rpm under no load during the following steps.
5. Touch "RECORD" on CONSULT-II screen.

DATA MONITOR	
MONITOR	NO DTC
ENG SPEED	XXX rpm
MAS A/F SE-B1	XXX V
COOLAN TEMP/S	XXX °C
HO2S1 (B1)	XXX V
HO2S1 MNTR (B1)	LEAN

SEF646Y

6. Check the following.
 - "HO2S1 MNTR (B1)/(B2)" in "DATA MONITOR" mode changes from "RICH" to "LEAN" to "RICH" more than 5 times in 10 seconds.
5 times (cycles) are counted as shown at right.
 - "HO2S1 (B1)/(B2)" voltage goes above 0.6V at least once.
 - "HO2S1 (B1)/(B2)" voltage goes below 0.3V at least once.
 - "HO2S1 (B1)/(B2)" voltage never exceeds 1.0V.

Bank 1	cycle	1	2	3	4	5
	HO2S1 MNTR (B1)	R-L-R-L-R-L-R-L-R-L-R				
Bank 2	cycle	1	2	3	4	5
	HO2S1 MNTR (B2)	R-L-R-L-R-L-R-L-R-L-R				
R means HO2S1 MNTR (B1)/(B2) indicates RICH L means HO2S1 MNTR (B1)/(B2) indicates LEAN						

SEF647Y

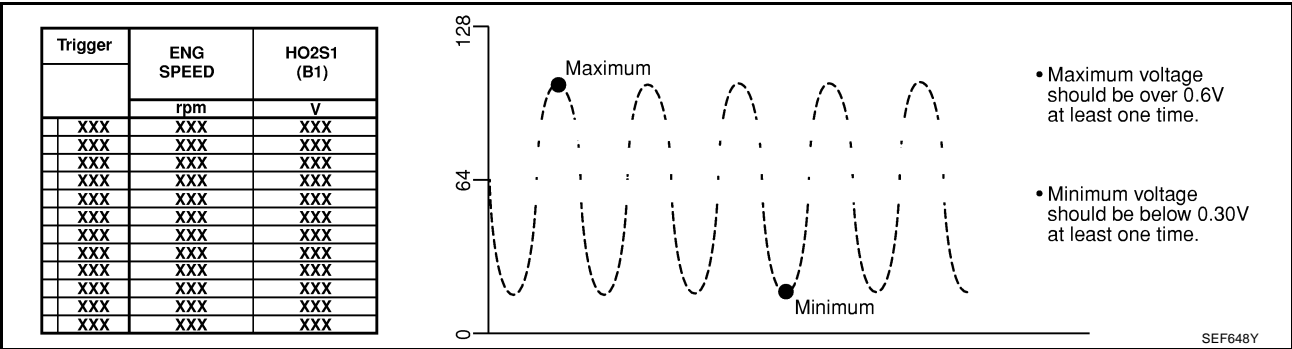

CAUTION:

- Discard any heated oxygen sensor which has been dropped from a height of more than 0.5 m (19.7 in) onto a hard surface such as a concrete floor; use a new one.
- Before installing new oxygen sensor, clean exhaust system threads using Oxygen Sensor Thread Cleaner tool J-43897-18 or J-43897-12 and approved anti-seize lubricant.

⊗ Without CONSULT-II

1. Start engine and warm it up to normal operating temperature.
2. Set voltmeter probes between ECM terminal 16 [HO2S1 (B1) signal] or 35 [HO2S1 (B2) signal] and ground.
3. Check the following with engine speed held at 2,000 rpm constant under no load.
 - The voltage fluctuates between 0 to 0.3V and 0.6 to 1.0V more than 5 times within 10 seconds.
 - The maximum voltage is over 0.6V at least 1 time.
 - The minimum voltage is below 0.3V at least 1 time.
 - The voltage never exceeds 1.0V.

1 time: 0 - 0.3V → 0.6 - 1.0V → 0 - 0.3V
 2 times: 0 - 0.3V → 0.6 - 1.0V → 0 - 0.3V → 0.6 - 1.0V → 0 - 0.3V

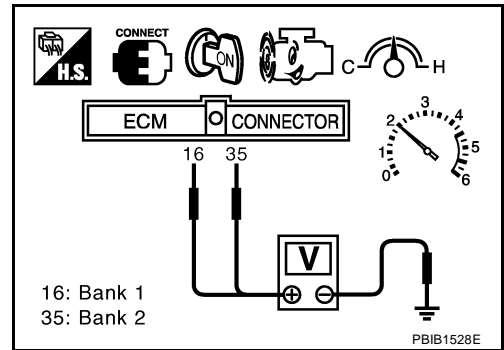

CAUTION:

- Discard any heated oxygen sensor which has been dropped from a height of more than 0.5 m (19.7 in) onto a hard surface such as a concrete floor; use a new one.
- Before installing new oxygen sensor, clean exhaust system threads using Oxygen Sensor Thread Cleaner tool J-43897-18 or J-43897-12 and approved anti-seize lubricant.

**Removal and Installation
HEATED OXYGEN SENSOR 1**

ABS00C2U

Refer to [EM-178, "EXHAUST MANIFOLD AND THREE WAY CATALYST"](#) .

DTC P0133, P0153 HO2S1

PFP:22690

Component Description

ABS00C2V

The heated oxygen sensor 1 is placed into the exhaust manifold. It detects the amount of oxygen in the exhaust gas compared to the outside air. The heated oxygen sensor 1 has a closed-end tube made of ceramic zirconia. The zirconia generates voltage from approximately 1V in richer conditions to 0V in leaner conditions. The heated oxygen sensor 1 signal is sent to the ECM. The ECM adjusts the injection pulse duration to achieve the ideal air-fuel ratio. The ideal air-fuel ratio occurs near the radical change from 1 to 0V.

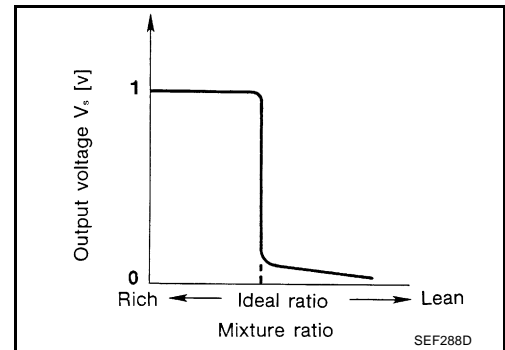
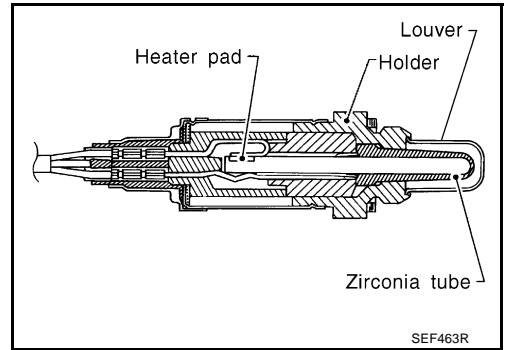

CONSULT-II Reference Value in Data Monitor Mode

ABS00C2W

Specification data are reference values.

MONITOR ITEM	CONDITION		SPECIFICATION
HO2S1 (B1) HO2S1 (B2)	● Engine: After warming up	Maintaining engine speed at 2,000 rpm	0 - 0.3V ↔ Approx. 0.6 - 1.0V
HO2S1 MNTR (B1) HO2S1 MNTR (B2)			LEAN ↔ RICH Changes more than 5 times during 10 seconds.

On Board Diagnosis Logic

ABS00C2X

To judge the malfunction of heated oxygen sensor 1, this diagnosis measures response time of heated oxygen sensor 1 signal. The time is compensated by engine operating (speed and load), fuel feedback control constant, and heated oxygen sensor 1 temperature index. Judgment is based on whether the compensated time (heated oxygen sensor 1 cycling time index) is inordinately long or not.

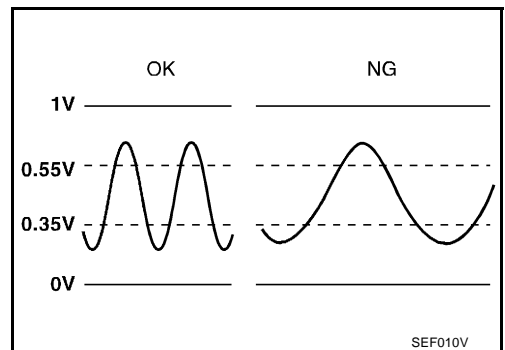

DTC No.	Trouble diagnosis name	DTC detecting condition	Possible cause
P0133 0133 (Bank 1)	Heated oxygen sensor 1 circuit slow response	The response of the voltage signal from the sensor takes more than the specified time.	<ul style="list-style-type: none"> ● Harness or connectors (The sensor circuit is open or shorted) ● Heated oxygen sensor 1 ● Fuel pressure ● Fuel injector ● Intake air leaks ● Exhaust gas leaks ● PCV valve ● Mass air flow sensor
P0153 0153 (Bank 2)			

DTC Confirmation Procedure

ABS00C2Y

CAUTION:

Always drive vehicle at a safe speed.

NOTE:

If DTC Confirmation Procedure has been previously conducted, always turn ignition switch OFF and wait at least 10 seconds before conducting the next test.

TESTING CONDITION:

- Always perform at a temperature above -10°C (14°F).
- Before performing the following procedure, confirm that battery voltage is more than 11V at idle.

WITH CONSULT-II

1. Start engine and warm it up to normal operating temperature.
2. Stop engine and wait at least 10 seconds.
3. Turn ignition switch ON and select "HO2S1 (B1) P0133" or "HO2S1 (B2) P0153" of "HO2S1" in "DTC WORK SUPPORT" mode with CONSULT-II.
4. Touch "START".
5. Start engine and let it idle for at least 3 minutes.

NOTE:

Do not raise engine speed above 3,000 rpm after this step. If the engine speed limit is exceeded, return to step 5.

HO2S1 (B1) P0133	
OUT OF CONDITION	
MONITOR	
ENG SPEED	XXX rpm
B/FUEL SCHDL	XXX msec
COOLAN TEMP/S	XXX °C
VHCL SPEED SEN	XXX km/h

SEF338Z

6. When the following conditions are met, "TESTING" will be displayed on the CONSULT-II screen. Maintain the conditions continuously until "TESTING" changes to "COMPLETED". (It will take approximately 40 to 50 seconds.)

ENG SPEED	1,350 - 2,900 rpm
VHCL SPEED SE	More than 80 km/h (50 MPH)
B/FUEL SCHDL	1.6 - 12.0 msec
Selector lever	Suitable position

HO2S1 (B1) P0133	
TESTING	
MONITOR	
ENG SPEED	XXX rpm
B/FUEL SCHDL	XXX msec
COOLAN TEMP/S	XXX °C
VHCL SPEED SEN	XXX km/h

SEF339Z

If "TESTING" is not displayed after 5 minutes, retry from step 2.

7. Make sure that "OK" is displayed after touching "SELF-DIAG RESULTS". If "NG" is displayed, refer to [EC-878, "Diagnostic Procedure"](#).

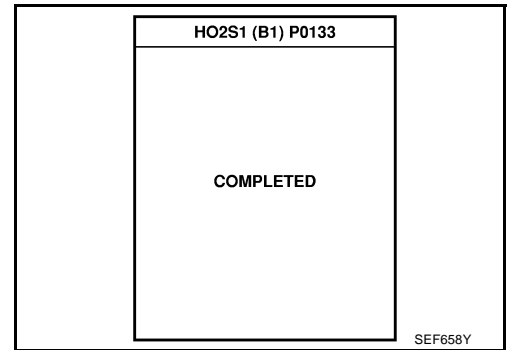

Overall Function Check

ABS00C2Z

Use this procedure to check the overall function of the heated oxygen sensor 1 circuit. During this check, a 1st trip DTC might not be confirmed.

WITH GST

1. Start engine and warm it up to normal operating temperature.
2. Set voltmeter probes between ECM terminal 16 [HO2S1(B1) signal] or 35 [HO2S1(B2) signal] and ground.
3. Check the following with engine speed held at 2,000 rpm constant under no load.
 - The voltage fluctuates between 0 to 0.3V and 0.6 to 1.0V more than 5 times within 10 seconds.

1 time: 0 - 0.3V → 0.6 - 1.0V → 0 - 0.3V

2 times: 0 - 0.3V → 0.6 - 1.0V → 0 - 0.3V → 0.6 - 1.0V → 0 - 0.3V

4. If NG, go to [EC-878, "Diagnostic Procedure"](#).

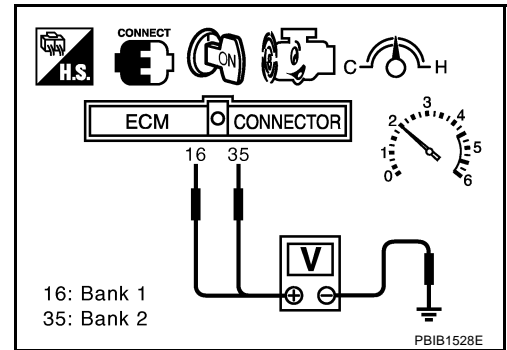

Wiring Diagram
BANK 1

EC-O2S1B1-01

— : DETECTABLE LINE FOR DTC
— : NON-DETECTABLE LINE FOR DTC

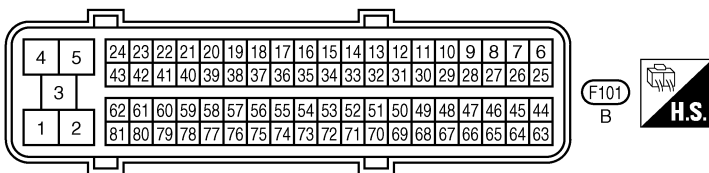
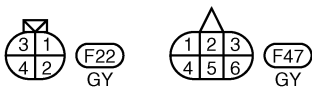
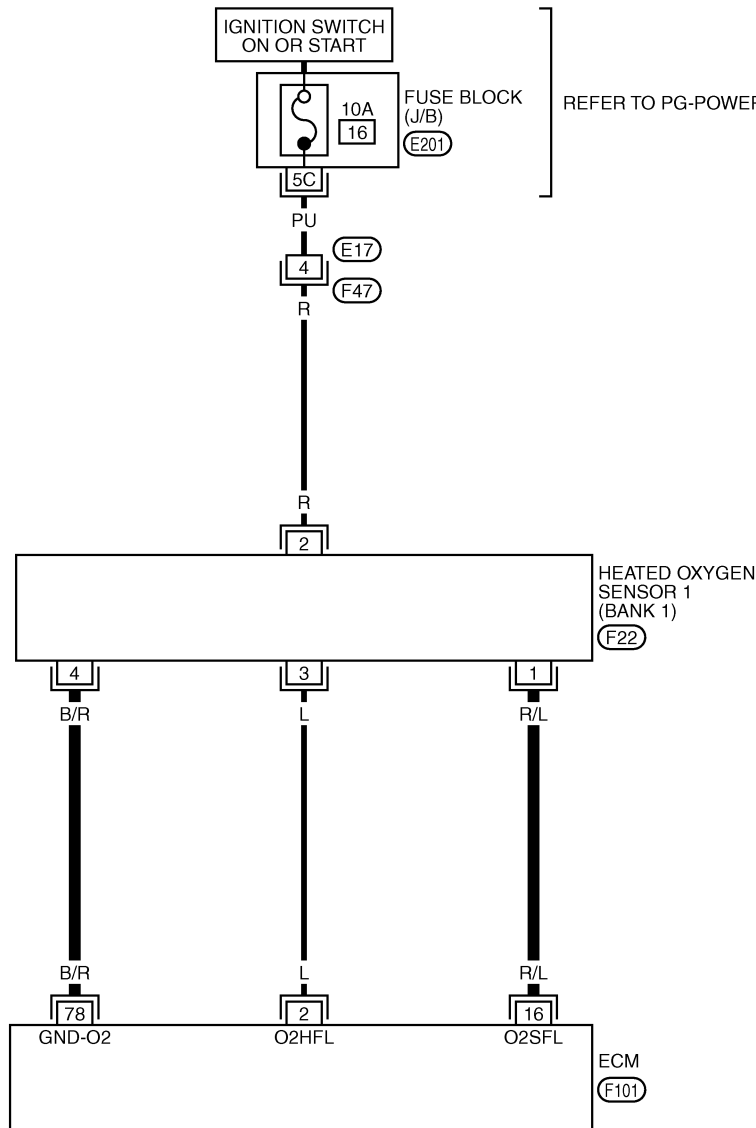

REFER TO THE FOLLOWING.
E201 - FUSE BLOCK-JUNCTION BOX (J/B)

DTC P0133, P0153 HO2S1

[VK45DE]

Specification data are reference values and are measured between each terminal and ground.

CAUTION:

Do not use ECM ground terminals when measuring input/output voltage. Doing so may result in damage to the ECM's transistor. Use a ground other than ECM terminals, such as the ground.

TER-MINAL NO.	WIRE COLOR	ITEM	CONDITION	DATA (DC Voltage)
16	R/L	Heated oxygen sensor 1 (bank 1)	[Engine is running] <ul style="list-style-type: none">● Warm-up condition● Engine speed is 2,000 rpm	0 - Approximately 1.0V (Periodically change)
78	B/R	Sensor ground (Heated oxygen sensor)	[Engine is running] <ul style="list-style-type: none">● Warm-up condition● Idle speed	Approximately 0V

BANK 2

EC-O2S1B2-01

— : DETECTABLE LINE FOR DTC
 — : NON-DETECTABLE LINE FOR DTC

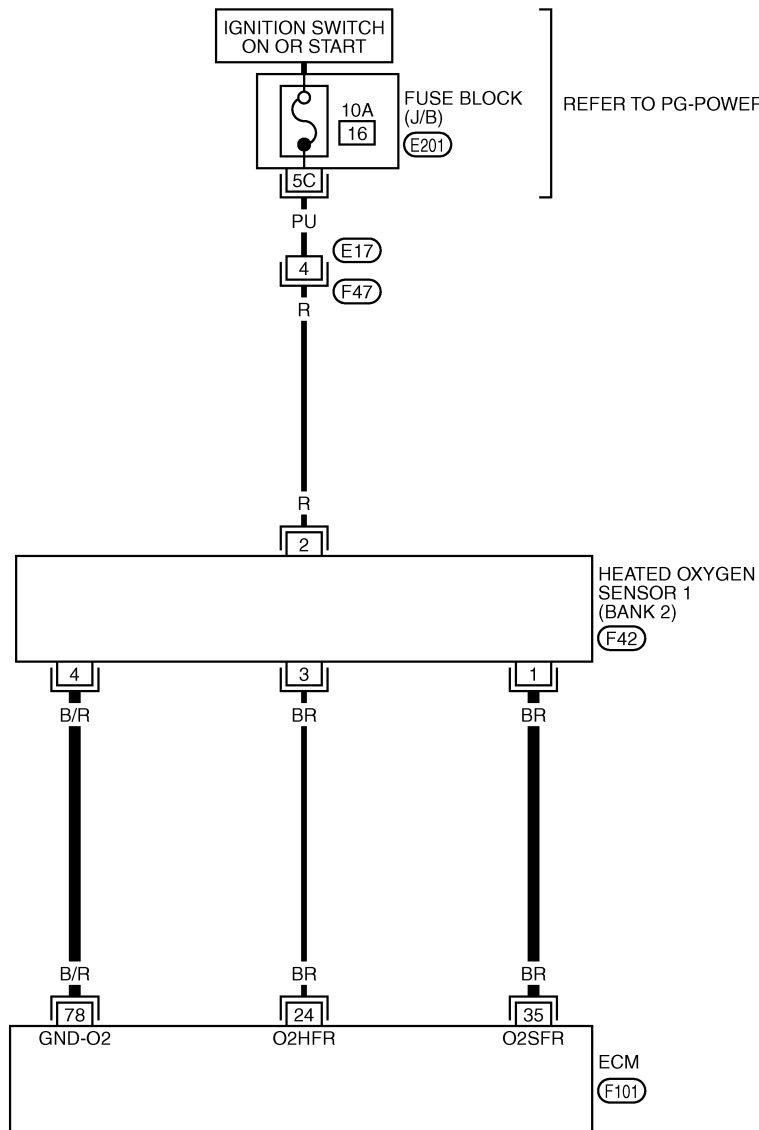

REFER TO PG-POWER.

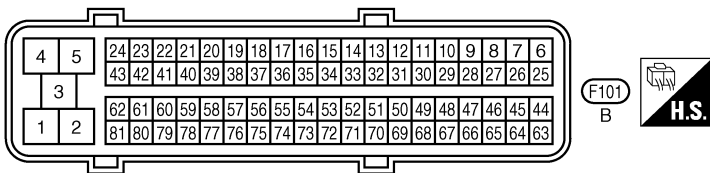
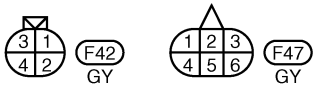

REFER TO THE FOLLOWING.
 (E201) - FUSE BLOCK-JUNCTION BOX (J/B)

Specification data are reference values and are measured between each terminal and ground.

CAUTION:

Do not use ECM ground terminals when measuring input/output voltage. Doing so may result in damage to the ECM's transistor. Use a ground other than ECM terminals, such as the ground.

TER-MINAL NO.	WIRE COLOR	ITEM	CONDITION	DATA (DC Voltage)
35	BR	Heated oxygen sensor 1 (bank 2)	[Engine is running] ● Warm-up condition ● Engine speed is 2,000 rpm	0 - Approximately 1.0V (Periodically change)
78	B/R	Sensor ground (Heated oxygen sensor)	[Engine is running] ● Warm-up condition ● Idle speed	Approximately 0V

Diagnostic Procedure

ABS00C31

1. CHECK GROUND CONNECTIONS

1. Turn ignition switch OFF.
2. Loosen and retighten three ground screws on the body. Refer to [EC-791, "Ground Inspection"](#).

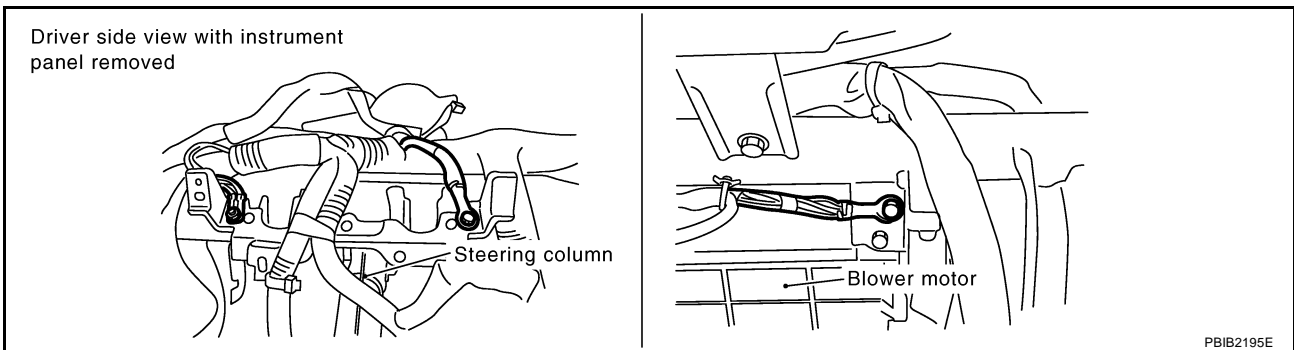

OK or NG

- OK >> GO TO 2.
- NG >> Repair or replace ground connections.

2. RETIGHTEN HEATED OXYGEN SENSOR 1

Loosen and retighten heated oxygen sensor 1.

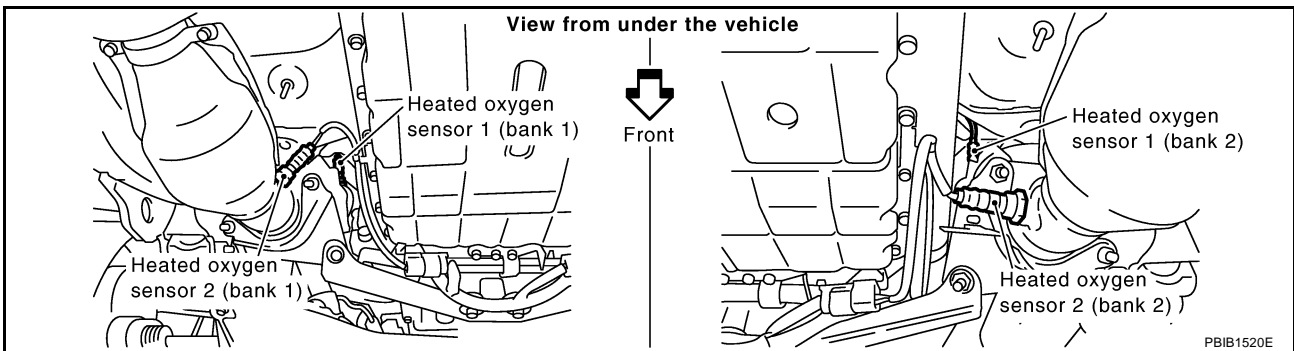

Tightening torque: 50 N·m (5.1 kg-m, 37 ft-lb)

>> GO TO 3.

3. CHECK FOR EXHAUST GAS LEAK

1. Start engine and run it at idle.
2. Listen for an exhaust gas leak before three way catalyst (manifold).

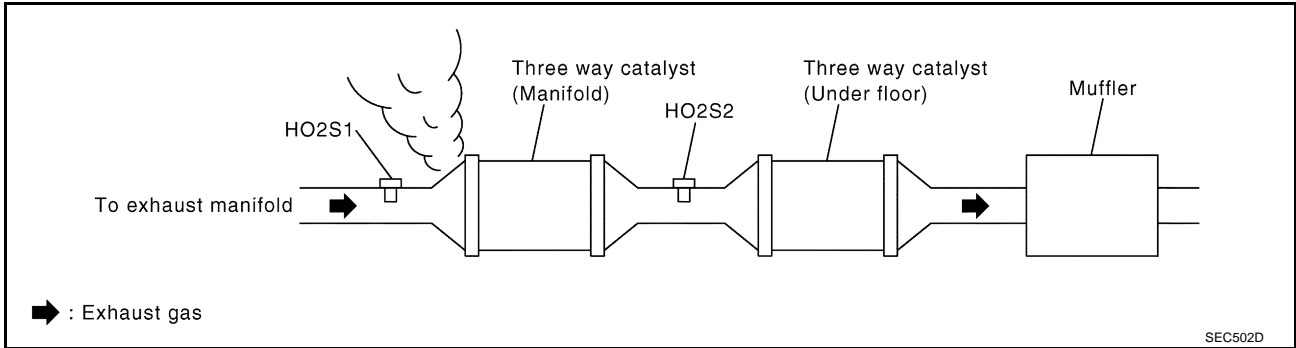

OK or NG

- OK >> GO TO 4.
 NG >> Repair or replace.

4. CHECK FOR INTAKE AIR LEAK

Listen for an intake air leak after the mass air flow sensor.

OK or NG

- OK >> GO TO 5.
 NG >> Repair or replace.

A
 EC
 C
 D
 E
 F
 G
 H
 I
 J
 K
 L
 M

5. CLEAR THE SELF-LEARNING DATA

With CONSULT-II

1. Start engine and warm it up to normal operating temperature.
2. Select "SELF-LEARNING CONT" in "WORK SUPPORT" mode with CONSULT-II.
3. Clear the self-learning control coefficient by touching "CLEAR".
4. Run engine for at least 10 minutes at idle speed.
Is the 1st trip DTC P0171, P0174 or P0172, P0175 detected?
Is it difficult to start engine?

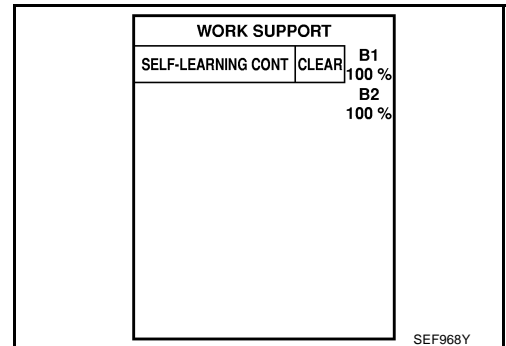

With GST

1. Start engine and warm it up to normal operating temperature.
2. Turn ignition switch OFF.
3. Disconnect mass air flow sensor harness connector, and restart and run engine for at least 5 seconds at idle speed.
4. Stop engine and reconnect mass air flow sensor harness connector.
5. Make sure DTC P0102 is displayed.
6. Erase the DTC memory. Refer to [EC-715, "HOW TO ERASE EMISSION-RELATED DIAGNOSTIC INFORMATION"](#).
7. Make sure DTC P0000 is displayed.
8. Run engine for at least 10 minutes at idle speed.
Is the 1st trip DTC P0171, P0174 or P0172, P0175 detected?
Is it difficult to start engine?

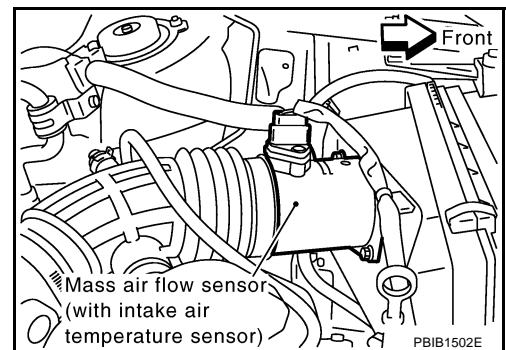

Yes or No

- Yes >> Perform trouble diagnosis for DTC P0171, P0174 or DTC P0172, P0175 (Refer to [EC-914](#) or [EC-923](#)).
- No >> GO TO 6.

6. CHECK HO2S1 GROUND CIRCUIT FOR OPEN AND SHORT

1. Turn ignition switch OFF.
2. Disconnect heated oxygen sensor 1 harness connector.

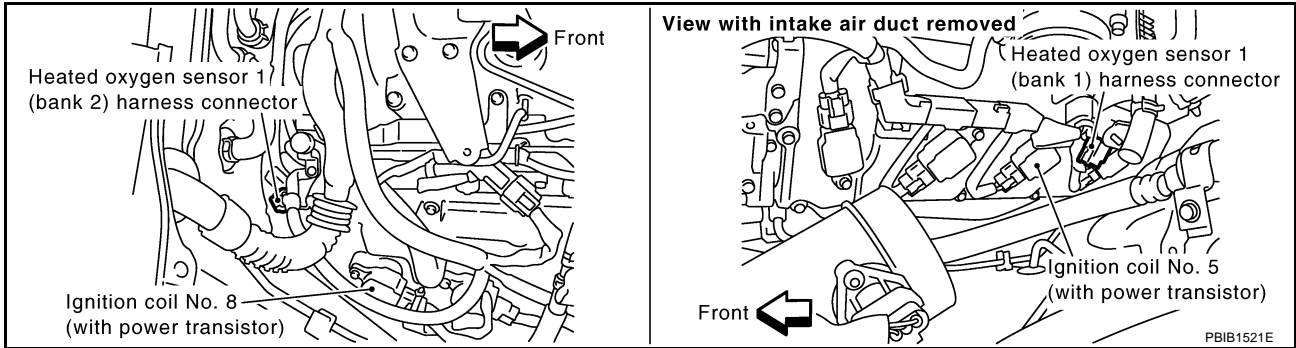

3. Disconnect ECM harness connector.
4. Check harness continuity between HO2S1 terminal 4 and ECM terminal 78. Refer to Wiring Diagram.

Continuity should exist.

5. Also check harness for short to ground and short to power.

OK or NG

OK >> GO TO 7.

NG >> Repair open circuit or short to ground or short to power in harness or connectors.

7. CHECK HO2S1 INPUT SIGNAL CIRCUIT FOR OPEN AND SHORT

1. Check harness continuity between ECM terminal and HO2S1 terminal as follows. Refer to Wiring Diagram.

DTC	Terminals		Bank
	ECM	Sensor	
P0133	16	1	1
P0153	35	1	2

Continuity should exist.

2. Check harness continuity between the following terminals and ground. Refer to Wiring Diagram.

DTC	Terminals		Bank
	ECM	Sensor	
P0133	16	1	1
P0153	35	1	2

Continuity should not exist.

3. Also check harness for short to ground and short to power.

OK or NG

OK >> GO TO 8.

NG >> Repair open circuit or short to ground or short to power in harness or connectors.

8. CHECK MASS AIR FLOW SENSOR

Refer to [EC-829, "Component Inspection"](#) .

OK or NG

- OK >> GO TO 9.
- NG >> Replace mass air flow sensor.

9. CHECK PCV VALVE

Refer to [EC-1332, "Component Inspection"](#) .

OK or NG

- OK >> GO TO 10.
- NG >> Replace PCV valve.

10. CHECK HEATED OXYGEN SENSOR 1

Refer to [EC-882, "Component Inspection"](#) .

OK or NG

- OK >> GO TO 11.
- NG >> Replace malfunctioning heated oxygen sensor 1.

11. CHECK INTERMITTENT INCIDENT

Refer to [EC-784, "TROUBLE DIAGNOSIS FOR INTERMITTENT INCIDENT"](#) .

>> INSPECTION END

Component Inspection HEATED OXYGEN SENSOR 1

ABS00C32

④ With CONSULT-II

1. Start engine and warm it up to normal operating temperature.
2. Select "MANU TRIG" and adjust "TRIGGER POINT" to 100% in "DATA MONITOR" mode with CONSULT-II.
3. Select "HO2S1 (B1)/(B2)" and "HO2S1 MNTR (B1)/(B2)".
4. Hold engine speed at 2,000 rpm under no load during the following steps.
5. Touch "RECORD" on CONSULT-II screen.

DATA MONITOR	
MONITOR	NO DTC
ENG SPEED	XXX rpm
MAS A/F SE-B1	XXX V
COOLAN TEMP/S	XXX °C
HO2S1 (B1)	XXX V
HO2S1 MNTR (B1)	LEAN

SEF646Y

6. Check the following.

- “HO2S1 MNTR (B1)/(B2)” in “DATA MONITOR” mode changes from “RICH” to “LEAN” to “RICH” more than 5 times in 10 seconds.
5 times (cycles) are counted as shown at right.
- “HO2S1 (B1)/(B2)” voltage goes above 0.6V at least once.
- “HO2S1 (B1)/(B2)” voltage goes below 0.3V at least once.
- “HO2S1 (B1)/(B2)” voltage never exceeds 1.0V.

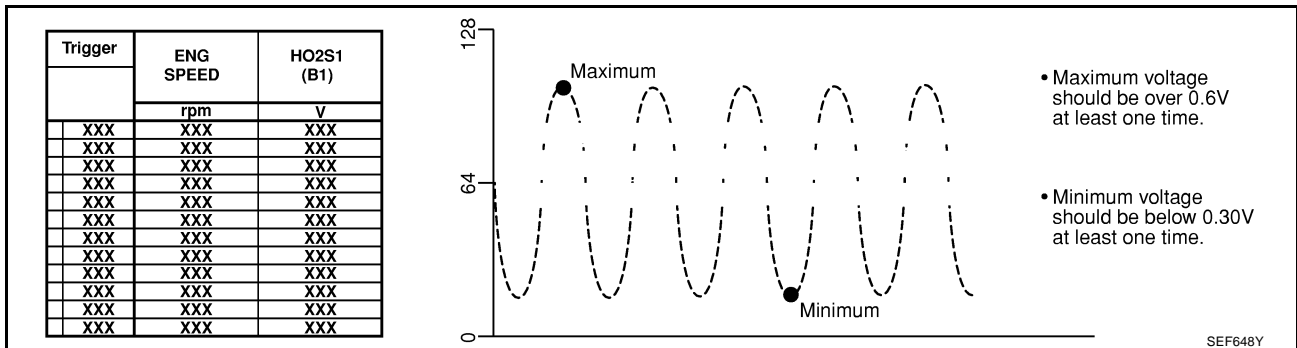
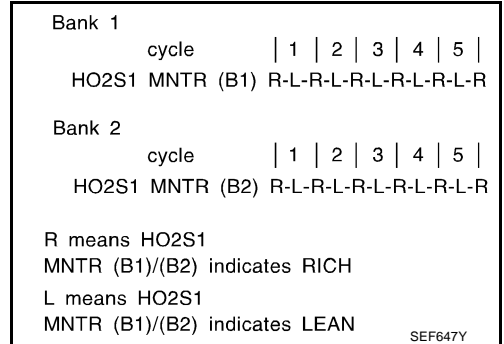

CAUTION:

- Discard any heated oxygen sensor which has been dropped from a height of more than 0.5 m (19.7 in) onto a hard surface such as a concrete floor; use a new one.
- Before installing new oxygen sensor, clean exhaust system threads using Oxygen Sensor Thread Cleaner tool J-43897-18 or J-43897-12 and approved anti-seize lubricant.

⊗ Without CONSULT-II

1. Start engine and warm it up to normal operating temperature.
2. Set voltmeter probes between ECM terminal 16 [HO2S1 (B1) signal] or 35 [HO2S1 (B2) signal] and ground.
3. Check the following with engine speed held at 2,000 rpm constant under no load.
 - The voltage fluctuates between 0 to 0.3V and 0.6 to 1.0V more than 5 times within 10 seconds.
 - The maximum voltage is over 0.6V at least 1 time.
 - The minimum voltage is below 0.3V at least 1 time.
 - The voltage never exceeds 1.0V.

1 time: 0 - 0.3V → 0.6 - 1.0V → 0 - 0.3V
 2 times: 0 - 0.3V → 0.6 - 1.0V → 0 - 0.3V → 0.6 - 1.0V → 0 - 0.3V

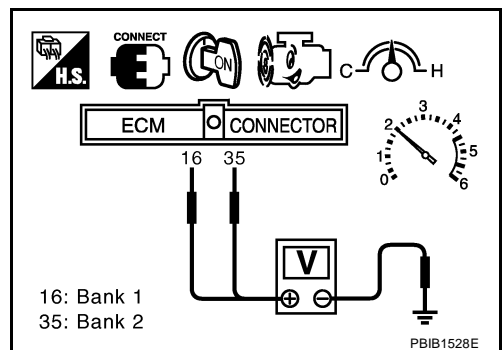

CAUTION:

- Discard any heated oxygen sensor which has been dropped from a height of more than 0.5 m (19.7 in) onto a hard surface such as a concrete floor; use a new one.
- Before installing new oxygen sensor, clean exhaust system threads using Oxygen Sensor Thread Cleaner tool J-43897-18 or J-43897-12 and approved anti-seize lubricant.

Removal and Installation HEATED OXYGEN SENSOR 1

ABS00C33

Refer to [EM-178, "EXHAUST MANIFOLD AND THREE WAY CATALYST"](#).

DTC P0134, P0154 HO2S1

PFP:22690

Component Description

ABS00C34

The heated oxygen sensor 1 is placed into the exhaust manifold. It detects the amount of oxygen in the exhaust gas compared to the outside air. The heated oxygen sensor 1 has a closed-end tube made of ceramic zirconia. The zirconia generates voltage from approximately 1V in richer conditions to 0V in leaner conditions. The heated oxygen sensor 1 signal is sent to the ECM. The ECM adjusts the injection pulse duration to achieve the ideal air-fuel ratio. The ideal air-fuel ratio occurs near the radical change from 1 to 0V.

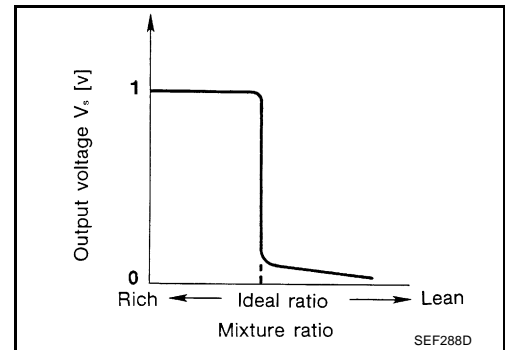
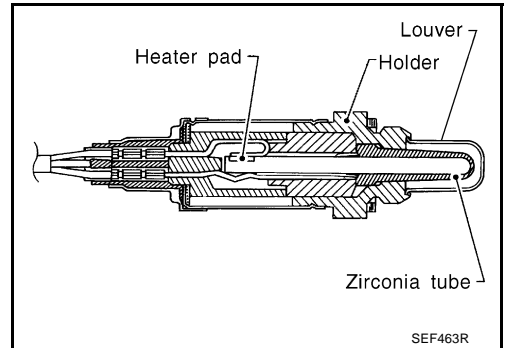

CONSULT-II Reference Value in Data Monitor Mode

ABS00C35

Specification data are reference values.

MONITOR ITEM	CONDITION		SPECIFICATION
HO2S1 (B1) HO2S1 (B2)	● Engine: After warming up	Maintaining engine speed at 2,000 rpm	0 - 0.3V ↔ Approx. 0.6 - 1.0V
HO2S1 MNTR (B1) HO2S1 MNTR (B2)			LEAN ↔ RICH Changes more than 5 times during 10 seconds.

On Board Diagnosis Logic

ABS00C36

Under the condition in which the heated oxygen sensor 1 signal is not input, the ECM circuits will read a continuous approximately 0.3V. Therefore, for this diagnosis, the time that output voltage is within 200 to 400 mV range is monitored, and the diagnosis checks that this time is not inordinately long.

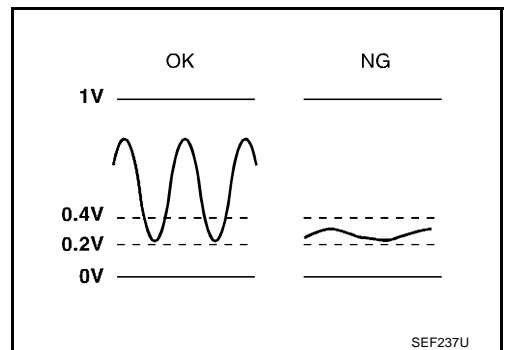

DTC No.	Trouble diagnosis name	DTC detecting condition	Possible cause
P0134 0134 (Bank 1)	Heated oxygen sensor 1 circuit no activity detected	The voltage from the sensor is constantly approx. 0.3V.	<ul style="list-style-type: none"> ● Harness or connectors (The sensor circuit is open or shorted) ● Heated oxygen sensor 1
P0154 0154 (Bank 2)			

DTC Confirmation Procedure

CAUTION:

Always drive vehicle at a safe speed.

NOTE:

If DTC Confirmation Procedure has been previously conducted, always turn ignition switch OFF and wait at least 10 seconds before conducting the next test.

TESTING CONDITION:

Before performing the following procedure, confirm that battery voltage is more than 11V at idle.

WITH CONSULT-II

1. Start engine and warm it up to normal operating temperature.
2. Select "HO2S1 (B1) P0134" or "HO2S1 (B2) P0154" of "HO2S1" in "DTC WORK SUPPORT" mode with CONSULT-II.
3. Touch "START".
4. Let it idle for at least 3 minutes.

NOTE:

Do not raise engine speed above 3,000 rpm after this step. If the engine speed limit is exceeded, return to step 4.

HO2S1 (B1) P0134	
OUT OF CONDITION	
MONITOR	
ENG SPEED	XXX rpm
B/FUEL SCHDL	XXX msec
COOLAN TEMP/S	XXX °C
VHCL SPEED SEN	XXX km/h

PBIB0544E

5. When the following conditions are met, "TESTING" will be displayed on the CONSULT-II screen. Maintain the conditions continuously until "TESTING" changes to "COMPLETED". (It will take approximately 10 to 60 seconds.)

ENG SPEED	1,000 - 2,300 rpm
VHCL SPEED SE	More than 64 km/h (40 MPH)
B/FUEL SCHDL	1.5 - 15.0 msec
Selector lever	Suitable position

HO2S1 (B1) P0134	
TESTING	
MONITOR	
ENG SPEED	XXX rpm
B/FUEL SCHDL	XXX msec
COOLAN TEMP/S	XXX °C
VHCL SPEED SEN	XXX km/h

PBIB0545E

If "TESTING" is not displayed after 5 minutes, retry from step 2.

6. Make sure that "OK" is displayed after touching "SELF-DIAG RESULTS". If "NG" is displayed, refer to [EC-890, "Diagnostic Procedure"](#).

HO2S1 (B1) P0134	
COMPLETED	

SEC750C

Overall Function Check

Use this procedure to check the overall function of the heated oxygen sensor 1 circuit. During this check, a 1st trip DTC might not be confirmed.

WITH GST

1. Start engine and warm it up to normal operating temperature.
2. Set voltmeter probes between ECM terminal 16 [HO2S1 (B1) signal] or 35 [HO2S1 (B2) signal] and ground.
3. Check the following with engine speed held at 2,000 rpm constant under no load.
 - The voltage does not remain in the range of 0.2 to 0.4V.
4. If NG, go to [EC-890, "Diagnostic Procedure"](#).

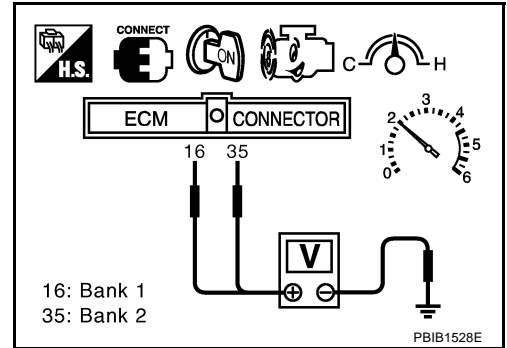

Wiring Diagram
BANK 1

EC-O2S1B1-01

— : DETECTABLE LINE FOR DTC
 — : NON-DETECTABLE LINE FOR DTC

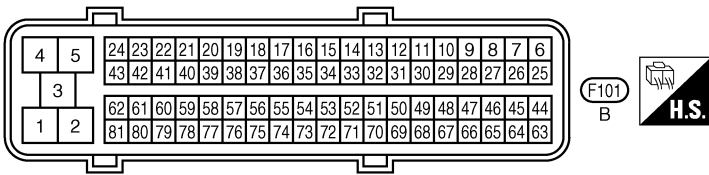
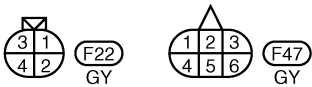
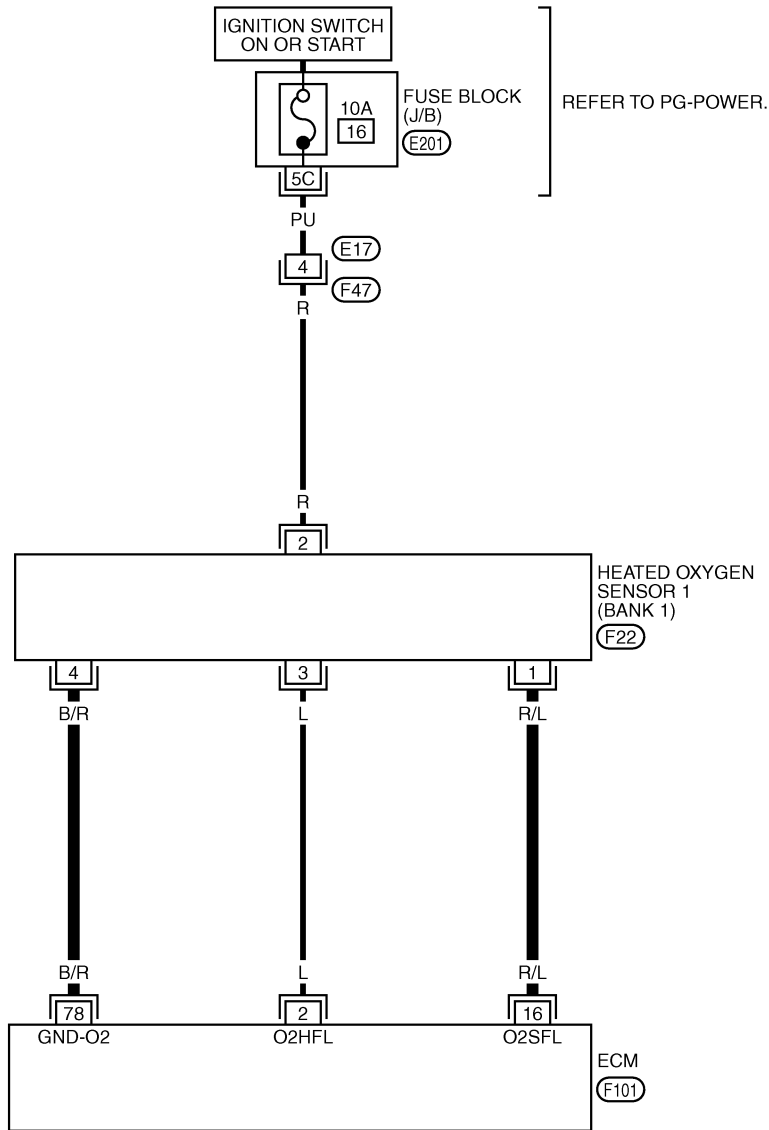

REFER TO THE FOLLOWING.
 (E201) - FUSE BLOCK-JUNCTION BOX (J/B)

DTC P0134, P0154 HO2S1

[VK45DE]

Specification data are reference values and are measured between each terminal and ground.

CAUTION:

Do not use ECM ground terminals when measuring input/output voltage. Doing so may result in damage to the ECM's transistor. Use a ground other than ECM terminals, such as the ground.

TER-MINAL NO.	WIRE COLOR	ITEM	CONDITION	DATA (DC Voltage)
16	R/L	Heated oxygen sensor 1 (bank 1)	[Engine is running] <ul style="list-style-type: none">● Warm-up condition● Engine speed is 2,000 rpm	0 - Approximately 1.0V (Periodically change)
78	B/R	Sensor ground (Heated oxygen sensor)	[Engine is running] <ul style="list-style-type: none">● Warm-up condition● Idle speed	Approximately 0V

DTC P0134, P0154 HO2S1

[VK45DE]

BANK 2

EC-O2S1B2-01

: DETECTABLE LINE FOR DTC
 : NON-DETECTABLE LINE FOR DTC

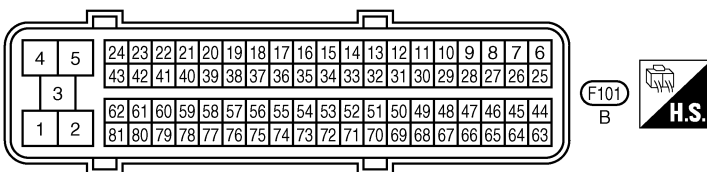
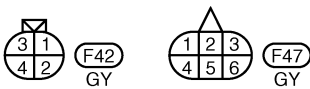
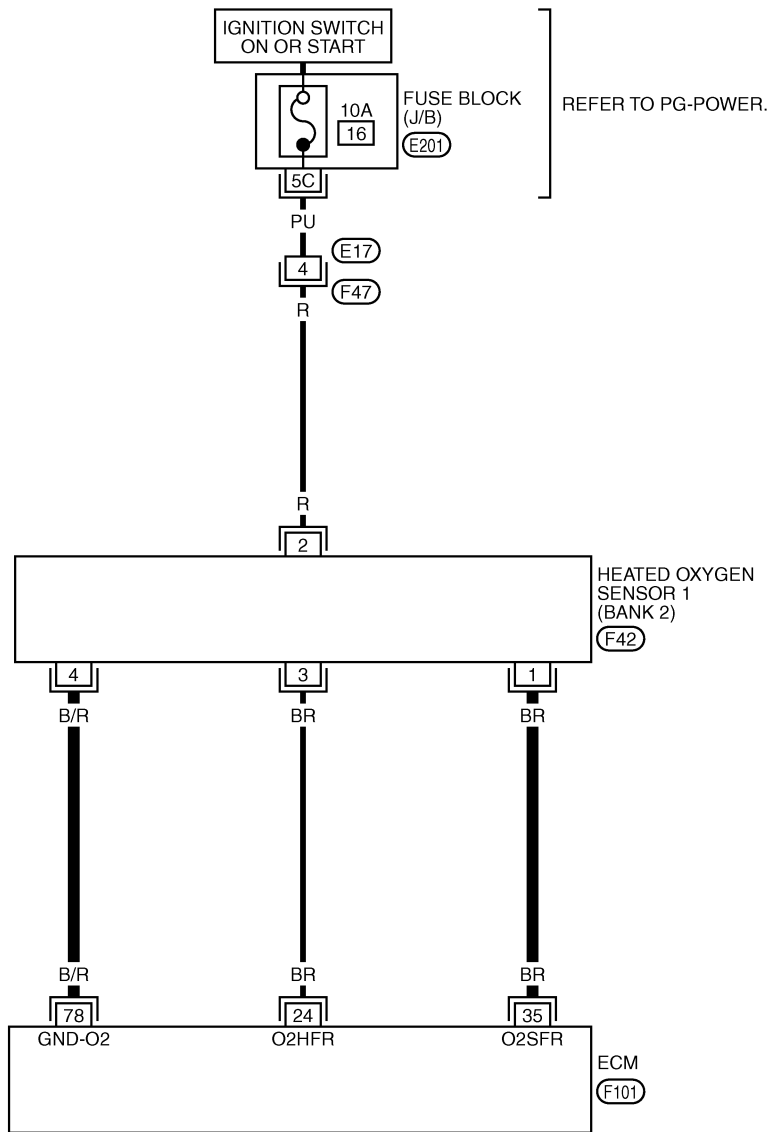

REFER TO THE FOLLOWING.
 (E201) - FUSE BLOCK-JUNCTION BOX (J/B)

TBWM0229E

Specification data are reference values and are measured between each terminal and ground.

CAUTION:

Do not use ECM ground terminals when measuring input/output voltage. Doing so may result in damage to the ECM's transistor. Use a ground other than ECM terminals, such as the ground.

TER-MINAL NO.	WIRE COLOR	ITEM	CONDITION	DATA (DC Voltage)
35	BR	Heated oxygen sensor 1 (bank 2)	[Engine is running] <ul style="list-style-type: none"> ● Warm-up condition ● Engine speed is 2,000 rpm 	0 - Approximately 1.0V (Periodically change)
78	B/R	Sensor ground (Heated oxygen sensor)	[Engine is running] <ul style="list-style-type: none"> ● Warm-up condition ● Idle speed 	Approximately 0V

Diagnostic Procedure

ABS00C3A

1. CHECK GROUND CONNECTIONS

1. Turn ignition switch OFF.
2. Loosen and retighten three ground screws on the body.
Refer to [EC-791, "Ground Inspection"](#).

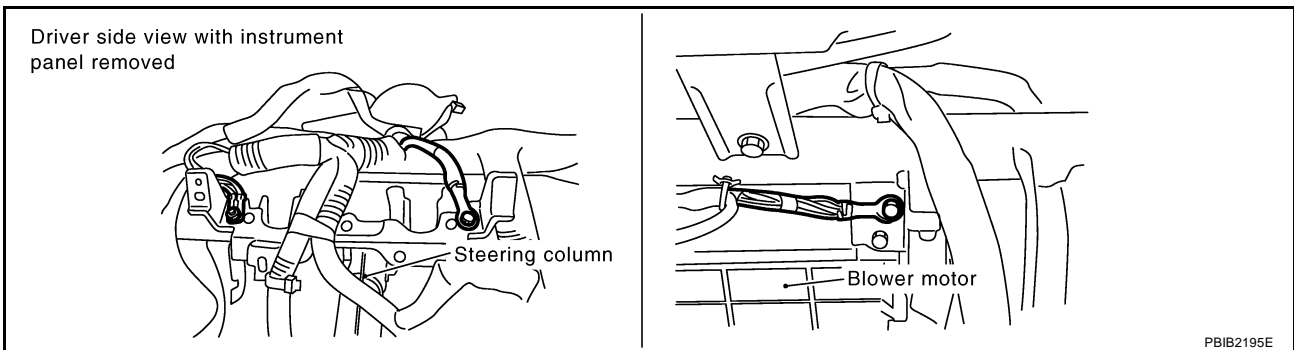

PBIB2195E

OK or NG

- OK >> GO TO 2.
- NG >> Repair or replace ground connections.

2. CHECK HO2S1 GROUND CIRCUIT FOR OPEN AND SHORT

1. Disconnect heated oxygen sensor 1 harness connector.

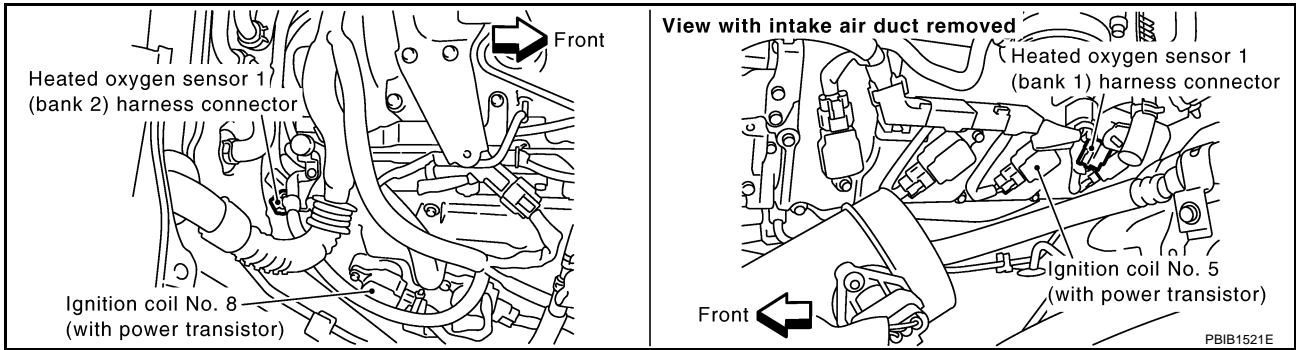

2. Disconnect ECM harness connector.
3. Check harness continuity between HO2S1 terminal 4 and ECM terminal 78.
Refer to Wiring Diagram.

Continuity should exist.

4. Also check harness for short to ground and short to power.

OK or NG

OK >> GO TO 3.

NG >> Repair open circuit or short to ground or short to power in harness or connectors.

3. CHECK HO2S1 INPUT SIGNAL CIRCUIT FOR OPEN AND SHORT

1. Check harness continuity between ECM terminal and HO2S1 terminal as follows.
Refer to Wiring Diagram.

DTC	Terminals		Bank
	ECM	Sensor	
P0134	16	1	1
P0154	35	1	2

Continuity should exist.

2. Check harness continuity between the following terminals and ground.
Refer to Wiring Diagram.

DTC	Terminals		Bank
	ECM	Sensor	
P0134	16	1	1
P0154	35	1	2

Continuity should not exist.

3. Also check harness for short to ground and short to power.

OK or NG

OK >> GO TO 4.

NG >> Repair open circuit or short to ground or short to power in harness or connectors.

4. CHECK HEATED OXYGEN SENSOR 1

Refer to [EC-892. "Component Inspection"](#) .

OK or NG

OK >> GO TO 5.

NG >> Replace malfunctioning heated oxygen sensor 1.

5. CHECK INTERMITTENT INCIDENT

Refer to [EC-784, "TROUBLE DIAGNOSIS FOR INTERMITTENT INCIDENT"](#).

>> INSPECTION END

Component Inspection HEATED OXYGEN SENSOR 1

ABS00C3B

With CONSULT-II

1. Start engine and warm it up to normal operating temperature.
2. Select "MANU TRIG" and adjust "TRIGGER POINT" to 100% in "DATA MONITOR" mode with CONSULT-II.
3. Select "HO2S1 (B1)/(B2)" and "HO2S1 MNTR (B1)/(B2)".
4. Hold engine speed at 2,000 rpm under no load during the following steps.
5. Touch "RECORD" on CONSULT-II screen.

DATA MONITOR	
MONITOR	NO DTC
ENG SPEED	XXX rpm
MAS A/F SE-B1	XXX V
COOLANTEMP/S	XXX °C
HO2S1 (B1)	XXX V
HO2S1 MNTR (B1)	LEAN

SEF646Y

6. Check the following.

- "HO2S1 MNTR (B1)/(B2)" in "DATA MONITOR" mode changes from "RICH" to "LEAN" to "RICH" more than 5 times in 10 seconds.
5 times (cycles) are counted as shown at right.
- "HO2S1 (B1)/(B2)" voltage goes above 0.6V at least once.
- "HO2S1 (B1)/(B2)" voltage goes below 0.3V at least once.
- "HO2S1 (B1)/(B2)" voltage never exceeds 1.0V.

Bank 1	cycle 1 2 3 4 5
	HO2S1 MNTR (B1) R-L-R-L-R-L-R-L-R-L-R
Bank 2	cycle 1 2 3 4 5
	HO2S1 MNTR (B2) R-L-R-L-R-L-R-L-R-L-R

R means HO2S1
MNTR (B1)/(B2) indicates RICH
L means HO2S1
MNTR (B1)/(B2) indicates LEAN

SEF647Y

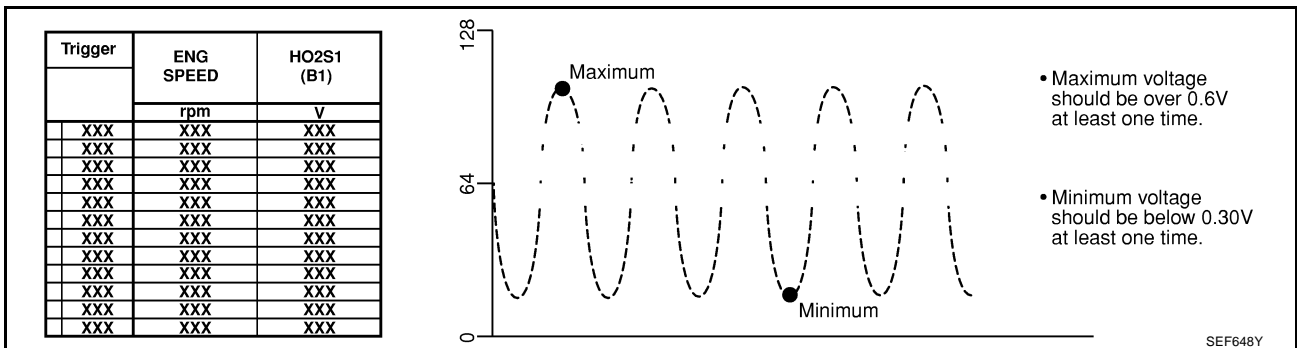

CAUTION:

- Discard any heated oxygen sensor which has been dropped from a height of more than 0.5 m (19.7 in) onto a hard surface such as a concrete floor; use a new one.
- Before installing new oxygen sensor, clean exhaust system threads using Oxygen Sensor Thread Cleaner tool J-43897-18 or J-43897-12 and approved anti-seize lubricant.

Without CONSULT-II

1. Start engine and warm it up to normal operating temperature.

2. Set voltmeter probes between ECM terminal 16 [HO2S1 (B1) signal] or 35 [HO2S1 (B2) signal] and ground.
3. Check the following with engine speed held at 2,000 rpm constant under no load.
 - The voltage fluctuates between 0 to 0.3V and 0.6 to 1.0V more than 5 times within 10 seconds.
 - The maximum voltage is over 0.6V at least 1 time.
 - The minimum voltage is below 0.3V at least 1 time.
 - The voltage never exceeds 1.0V.

1 time: 0 - 0.3V → 0.6 - 1.0V → 0 - 0.3V
 2 times: 0 - 0.3V → 0.6 - 1.0V → 0 - 0.3V → 0.6 - 1.0V → 0 - 0.3V

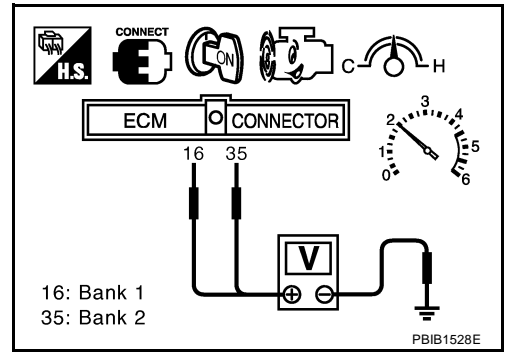

CAUTION:

- Discard any heated oxygen sensor which has been dropped from a height of more than 0.5 m (19.7 in) onto a hard surface such as a concrete floor; use a new one.
- Before installing new oxygen sensor, clean exhaust system threads using Oxygen Sensor Thread Cleaner tool J-43897-18 or J-43897-12 and approved anti-seize lubricant.

**Removal and Installation
HEATED OXYGEN SENSOR 1**

ABS00C3C

Refer to [EM-178. "EXHAUST MANIFOLD AND THREE WAY CATALYST"](#)

DTC P0138, P0158 HO2S2

PFP:226A0

Component Description

ABS00C3D

The heated oxygen sensor 2, after three way catalyst (manifold), monitors the oxygen level in the exhaust gas on each bank.

Even if switching characteristics of the heated oxygen sensor 1 are shifted, the air-fuel ratio is controlled to stoichiometric, by the signal from the heated oxygen sensor 2.

This sensor is made of ceramic zirconia. The zirconia generates voltage from approximately 1V in richer conditions to 0V in leaner conditions.

Under normal conditions the heated oxygen sensor 2 is not used for engine control operation.

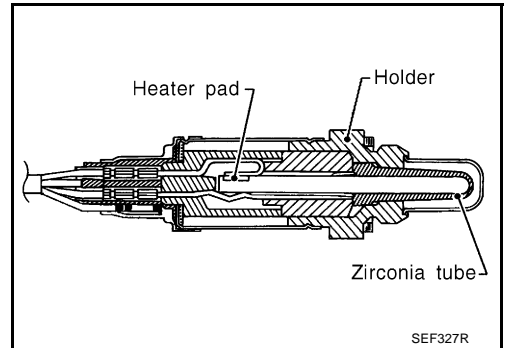

CONSULT-II Reference Value in Data Monitor Mode

ABS00C3E

Specification data are reference values.

MONITOR ITEM	CONDITION		SPECIFICATION
HO2S2 (B1) HO2S2 (B2)	<ul style="list-style-type: none"> ● Warm-up condition ● After keeping engine speed between 3,500 and 4,000 rpm for 1 minute and at idle for 1 minute under no load 	Revsing engine from idle to 3,000 rpm quickly	0 - 0.3V ↔ Approx. 0.6 - 1.0V
HO2S2 MNTR (B1) HO2S2 MNTR (B2)			LEAN ↔ RICH

On Board Diagnosis Logic

ABS00C3F

The heated oxygen sensor 2 has a much longer switching time between rich and lean than the heated oxygen sensor 1. The oxygen storage capacity of the three way catalyst (manifold) causes the longer switching time. To judge the malfunctions of heated oxygen sensor 2, ECM monitors whether the voltage is unusually high during the various driving condition such as fuel-cut.

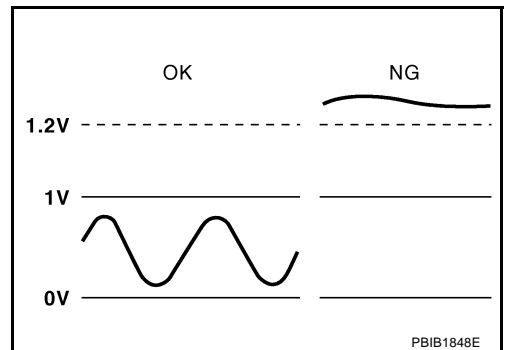

DTC No.	Trouble diagnosis name	DTC detecting condition	Possible cause
P0138 0138 (Bank 1)	Heated oxygen sensor 2 circuit high voltage	An excessively high voltage from the sensor is sent to ECM.	<ul style="list-style-type: none"> ● Harness or connectors (The sensor circuit is open or shorted) ● Heated oxygen sensor 2
P0158 0158 (Bank 2)			

DTC Confirmation Procedure**NOTE:**

If DTC Confirmation Procedure has been previously conducted, always turn ignition switch OFF and wait at least 10 seconds before conducting the next test.

Ⓟ WITH CONSULT-II

1. Turn ignition switch ON and select "DATA MONITOR" mode with CONSULT-II.
2. Start engine and warm it up to the normal operating temperature.
3. Turn ignition switch OFF and wait at least 10 seconds.
4. Start engine and keep the engine speed between 3,500 and 4,000 rpm for at least 1 minute under no load.
5. Let engine idle for 2 minutes.
6. If 1st trip DTC is detected, go to [EC-899, "Diagnostic Procedure"](#)

DATA MONITOR	
MONITOR	NO DTC
ENG SPEED	XXX rpm
COOLAN TEMP/S	XXX °C

SEF174Y

Ⓟ WITH GST

Follow the procedure "WITH CONSULT-II" above.

A

EC

C

D

E

F

G

H

I

J

K

L

M

Wiring Diagram
BANK 1

EC-O2S2B1-01

— : DETECTABLE LINE FOR DTC
 — : NON-DETECTABLE LINE FOR DTC

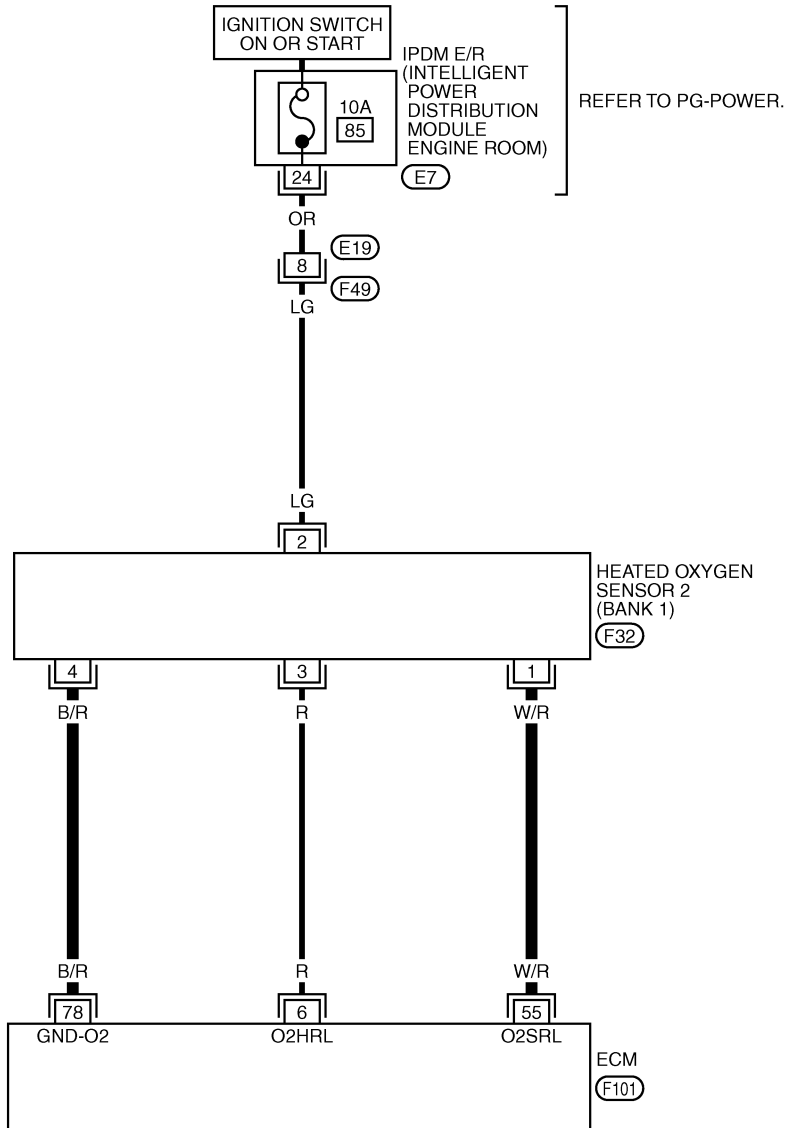

23	22	21	20	19	18	17		
32	31	30	29	28	27	26	25	24

(E7)
GY



3	1
4	2

(F32)
GY

1	2	3	4
5	6	7	8

(F49)
B

4	5	24	23	22	21	20	19	18	17	16	15	14	13	12	11	10	9	8	7	6
	3	43	42	41	40	39	38	37	36	35	34	33	32	31	30	29	28	27	26	25
		62	61	60	59	58	57	56	55	54	53	52	51	50	49	48	47	46	45	44
1	2	81	80	79	78	77	76	75	74	73	72	71	70	69	68	67	66	65	64	63

(F101)
B



DTC P0138, P0158 HO2S2

[VK45DE]

Specification data are reference values and are measured between each terminal and ground.

CAUTION:

Do not use ECM ground terminals when measuring input/output voltage. Doing so may result in damage to the ECM's transistor. Use a ground other than ECM terminals, such as the ground.

TER-MINAL NO.	WIRE COLOR	ITEM	CONDITION	DATA (DC Voltage)
55	W/R	Heated oxygen sensor 2 (bank 1)	[Engine is running] <ul style="list-style-type: none"> ● Warm-up condition ● Revving engine from idle to 3,000 rpm quickly after the following conditions are met <ul style="list-style-type: none"> – After keeping the engine speed between 3,500 and 4,000 rpm for 1 minute and at idle for 1 minute under no load 	0 - Approximately 1.0V
78	B/R	Sensor ground (Heated oxygen sensor)	[Engine is running] <ul style="list-style-type: none"> ● Warm-up condition ● Idle speed 	Approximately 0V

A
EC
C
D
E
F
G
H
I
J
K
L
M

BANK 2

EC-O2S2B2-01

— : DETECTABLE LINE FOR DTC
 — : NON-DETECTABLE LINE FOR DTC

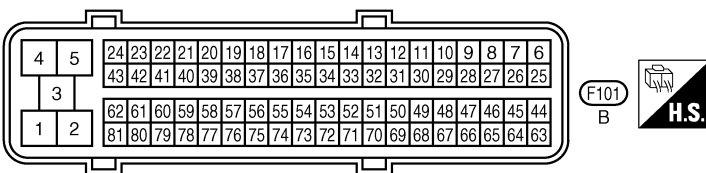
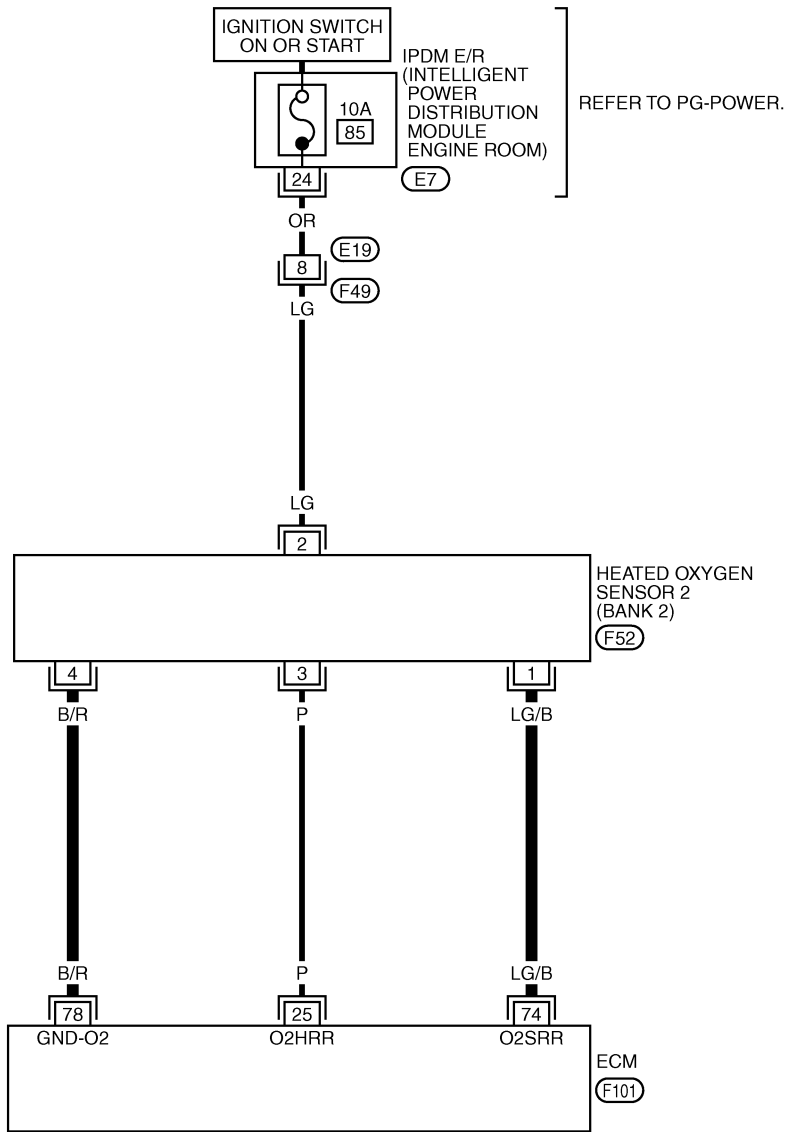

Specification data are reference values and are measured between each terminal and ground.

CAUTION:

Do not use ECM ground terminals when measuring input/output voltage. Doing so may result in damage to the ECM's transistor. Use a ground other than ECM terminals, such as the ground.

TER-MINAL NO.	WIRE COLOR	ITEM	CONDITION	DATA (DC Voltage)
74	LG/B	Heated oxygen sensor 2 (bank 2)	<p>[Engine is running]</p> <ul style="list-style-type: none"> ● Warm-up condition ● Revving engine from idle to 3,000 rpm quickly after the following conditions are met – After keeping the engine speed between 3,500 and 4,000 rpm for 1 minute and at idle for 1 minute under no load 	0 - Approximately 1.0V
78	B/R	Sensor ground (Heated oxygen sensor)	<p>[Engine is running]</p> <ul style="list-style-type: none"> ● Warm-up condition ● Idle speed 	Approximately 0V

Diagnostic Procedure

ABS00C3I

1. CHECK GROUND CONNECTIONS

1. Turn ignition switch OFF.
2. Loosen and retighten three ground screws on the body. Refer to [EC-791, "Ground Inspection"](#).

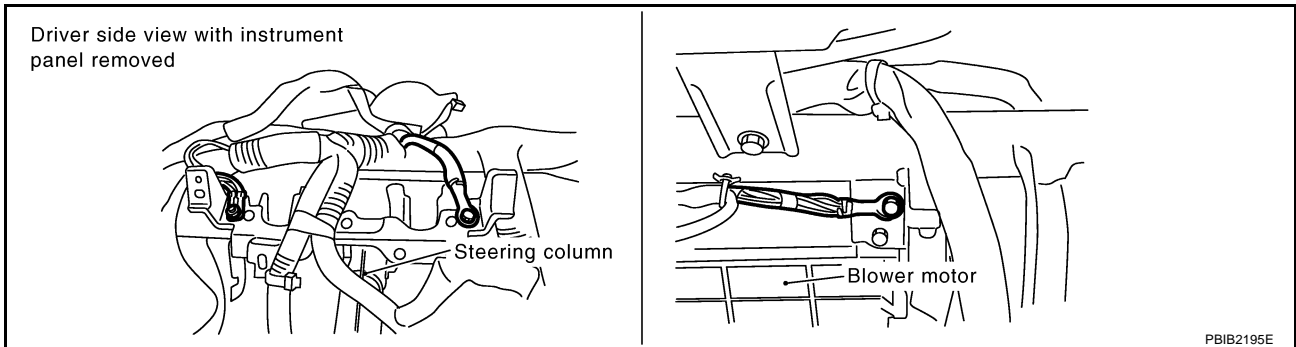

OK or NG

- OK >> GO TO 2.
- NG >> Repair or replace ground connections.

2. CHECK HO2S2 GROUND CIRCUIT FOR OPEN AND SHORT

1. Disconnect heated oxygen sensor 2 harness connector.

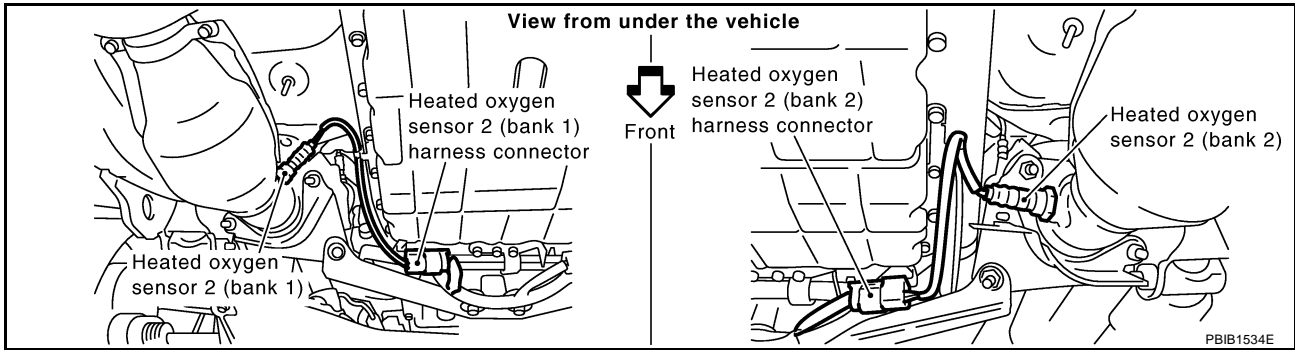

2. Disconnect ECM harness connector.
3. Check harness continuity between HO2S2 terminal 4 and ECM terminal 78.
Refer to Wiring Diagram.

Continuity should exist.

4. Also check harness for short to ground or short to power.

OK or NG

OK >> GO TO 3.

NG >> Repair open circuit or short to ground or short to power in harness or connectors.

3. CHECK HO2S2 INPUT SIGNAL CIRCUIT FOR OPEN AND SHORT

1. Check harness continuity between ECM terminal and HO2S2 terminal as follows.
Refer to Wiring Diagram.

DTC	Terminals		Bank
	ECM	Sensor	
P0138	55	1	1
P0158	74	1	2

Continuity should exist.

2. Check harness continuity between the following terminals and ground.
Refer to Wiring Diagram.

DTC	Terminals		Bank
	ECM	Sensor	
P0138	55	1	1
P0158	74	1	2

Continuity should not exist.

3. Also check harness for short to ground and short to power.

OK or NG

OK >> GO TO 4.

NG >> Repair open circuit or short to ground or short to power in harness or connectors.

4. CHECK HO2S2 CONNECTOR FOR WATER

1. Turn ignition switch OFF.
2. Disconnect heated oxygen sensor 2 harness connector.
3. Check connectors for water.

Water should not exist.

OK or NG

- OK >> GO TO 5.
- NG >> Repair or replace harness or connectors.

5. CHECK HEATED OXYGEN SENSOR 2

Refer to [EC-901, "Component Inspection"](#) .

OK or NG

- OK >> GO TO 6.
- NG >> Replace malfunctioning heated oxygen sensor 2.

6. CHECK INTERMITTENT INCIDENT

Refer to [EC-784, "TROUBLE DIAGNOSIS FOR INTERMITTENT INCIDENT"](#) .

>> INSPECTION END

Component Inspection HEATED OXYGEN SENSOR 2

ABS00C3J

With CONSULT-II

1. Turn ignition switch ON and select "DATA MONITOR" mode with CONSULT-II.
2. Start engine and warm it up to the normal operating temperature.
3. Turn ignition switch OFF and wait at least 10 seconds.
4. Start engine and keep the engine speed between 3,500 and 4,000 rpm for at least 1 minute under no load.
5. Let engine idle for 1 minute.

DATA MONITOR	
MONITOR	NO DTC
ENG SPEED	XXX rpm
COOLAN TEMP/S	XXX °C

SEF174Y

6. Select "FUEL INJECTION" in "ACTIVE TEST" mode, and select "HO2S2 (B1)/(B2)" as the monitor item with CONSULT-II.

ACTIVE TEST	
FUEL INJECTION	25 %
MONITOR	
ENG SPEED	XXX rpm
HO2S1 (B1)	XXX V
HO2S2 (B1)	XXX V
HO2S1 MNTR (B1)	RICH
HO2S2 MNTR (B1)	RICH

SEF662Y

7. Check "HO2S2 (B1)/(B2)" at idle speed when adjusting "FUEL INJECTION" to $\pm 25\%$.

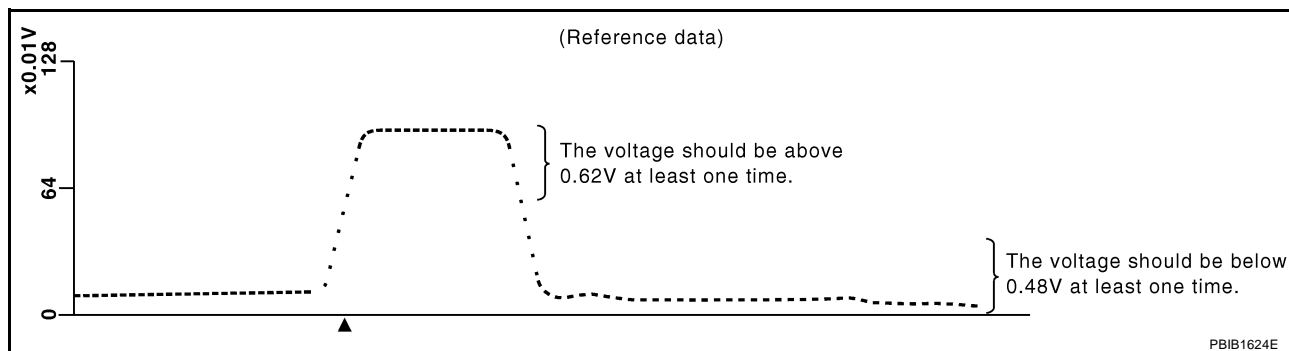

"HO2S2 (B1)/(B2)" should be above 0.62V at least once when the "FUEL INJECTION" is +25%.
 "HO2S2 (B1)/(B2)" should be below 0.48V at least once when the "FUEL INJECTION" is -25%.

CAUTION:

- Discard any heated oxygen sensor which has been dropped from a height of more than 0.5 m (19.7 in) onto a hard surface such as a concrete floor; use a new one.
- Before installing new oxygen sensor, clean exhaust system threads using Oxygen Sensor Thread Cleaner tool J-43897-18 or J-43897-12 and approved anti-seize lubricant.

⊗ Without CONSULT-II

1. Start engine and warm it up to the normal operating temperature.
2. Turn ignition switch OFF and wait at least 10 seconds.
3. Start engine and keep the engine speed between 3,500 and 4,000 rpm for at least 1 minute under no load.
4. Let engine idle for 1 minute.
5. Set voltmeter probes between ECM terminal 55 [HO2S2 (B1) signal] or 74 [HO2S2 (B2) signal] and ground.
6. Check the voltage when revving up to 4,000 rpm under no load at least 10 times.
 (Depress and release accelerator pedal as soon as possible.)
The voltage should be above 0.62V at least once during this procedure.
If the voltage is above 0.62V at step 6, step 7 is not necessary.
7. Keep vehicle at idling for 10 minutes, then check voltage. Or check the voltage when coasting from 80 km/h (50 MPH) in D position with "OD" OFF.
The voltage should be below 0.48V at least once during this procedure.
8. If NG, replace heated oxygen sensor 2.

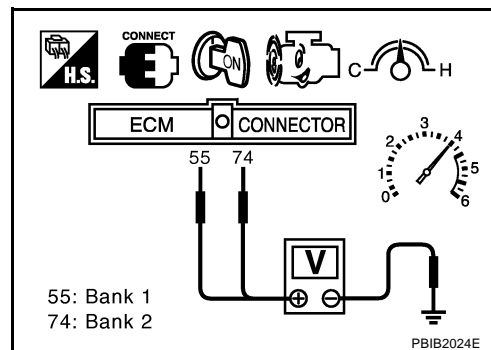

CAUTION:

- Discard any heated oxygen sensor which has been dropped from a height of more than 0.5 m (19.7 in) onto a hard surface such as a concrete floor; use a new one.
- Before installing new oxygen sensor, clean exhaust system threads (using Oxygen Sensor Thread Cleaner tool J-43897-18 or J-43897-12) and approved anti-seize lubricant.

Removal and Installation HEATED OXYGEN SENSOR 2

ABS00C3K

Refer to [EM-178, "EXHAUST MANIFOLD AND THREE WAY CATALYST"](#) .

DTC P0139, P0159 HO2S2

PFP:226A0

Component Description

ABS00C3L

The heated oxygen sensor 2, after three way catalyst (manifold), monitors the oxygen level in the exhaust gas on each bank.

Even if switching characteristics of the heated oxygen sensor 1 are shifted, the air-fuel ratio is controlled to stoichiometric, by the signal from the heated oxygen sensor 2.

This sensor is made of ceramic zirconia. The zirconia generates voltage from approximately 1V in richer conditions to 0V in leaner conditions.

Under normal conditions the heated oxygen sensor 2 is not used for engine control operation.

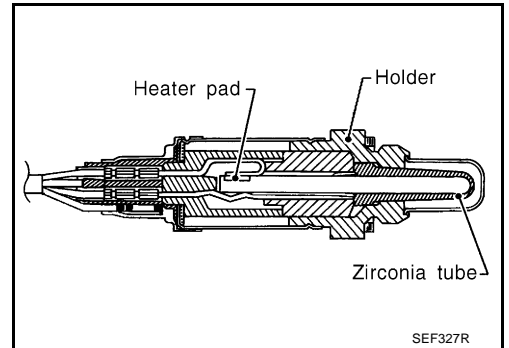

CONSULT-II Reference Value in Data Monitor Mode

ABS00C3M

Specification data are reference values.

MONITOR ITEM	CONDITION		SPECIFICATION
HO2S2 (B1) HO2S2 (B2)	<ul style="list-style-type: none"> ● Warm-up condition ● After keeping engine speed between 3,500 and 4,000 rpm for 1 minute and at idle for 1 minute under no load 	Revving engine from idle to 3,000 rpm quickly	0 - 0.3V ↔ Approx. 0.6 - 1.0V
HO2S2 MNTR (B1) HO2S2 MNTR (B2)			LEAN ↔ RICH

On Board Diagnosis Logic

ABS00C3N

The heated oxygen sensor 2 has a much longer switching time between rich and lean than the heated oxygen sensor 1. The oxygen storage capacity of the three way catalyst (manifold) causes the longer switching time. To judge the malfunctions of heated oxygen sensor 2, ECM monitors whether the switching response of the sensor's voltage is faster than specified during the various driving condition such as fuel-cut.

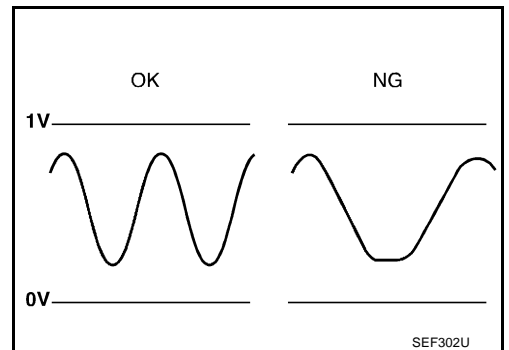

DTC No.	Trouble diagnosis name	DTC detecting condition	Possible cause
P0139 0139 (Bank 1)	Heated oxygen sensor 2 circuit slow response	It takes more time for the sensor to respond between rich and lean than the specified time.	<ul style="list-style-type: none"> ● Harness or connectors (The sensor circuit is open or shorted) ● Heated oxygen sensor 2
P0159 0159 (Bank 2)			<ul style="list-style-type: none"> ● Fuel pressure ● Fuel injector ● Intake air leaks

DTC Confirmation Procedure

NOTE:

If DTC Confirmation Procedure has been previously conducted, always turn ignition switch OFF and wait at least 10 seconds before conducting the next test.

WITH CONSULT-II

TESTING CONDITION:

For better results, perform "DTC WORK SUPPORT" at a temperature of 0 to 30 °C (32 to 86 °F).

1. Turn ignition switch ON and select "DATA MONITOR" mode with CONSULT-II.
2. Start engine and warm it up to the normal operating temperature.
3. Turn ignition switch OFF and wait at least 10 seconds.
4. Start engine and keep the engine speed between 3,500 and 4,000 rpm for at least 1 minute under no load.
5. Let engine idle for 1 minute.
6. Make sure that "COOLAN TEMP/S" indicates more than 70°C (158°F).
If not, warm up engine and go to next step when "COOLAN TEMP/S" indication reaches to 70°C (158°F).
7. Select "HO2S2 (B1) P0139" or "HO2S2 (B2) P0159" of "HO2S2" in "DTC WORK SUPPORT" mode with CONSULT-II.
8. Start engine and following the instruction of CONSULT-II.

DATA MONITOR	
MONITOR	NO DTC
ENG SPEED	XXX rpm
COOLAN TEMP/S	XXX °C

SEF174Y

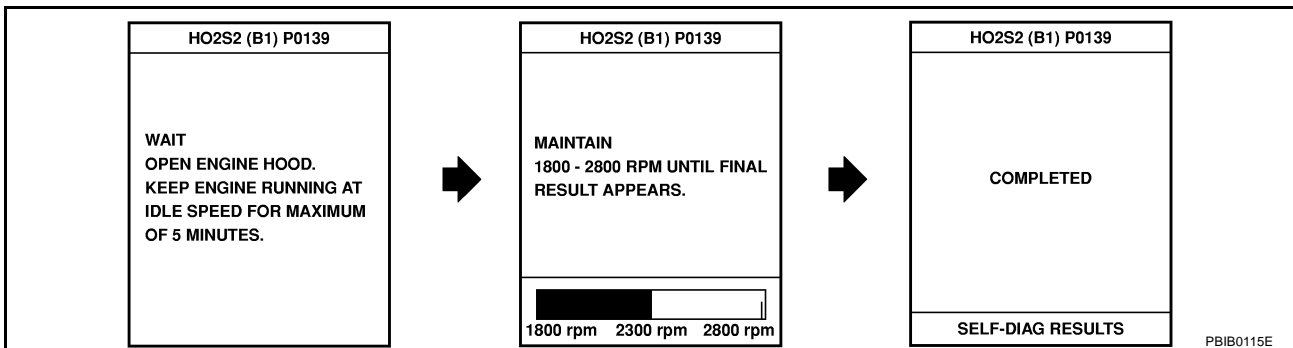

9. Make sure that "OK" is displayed after touching "SELF-DIAG RESULTS".
If "NG" is displayed, refer to [EC-909. "Diagnostic Procedure"](#).
If "CAN NOT BE DIAGNOSED" is displayed, perform the following.
 - a. Turn ignition switch OFF and leave the vehicle in a cool place (soak the vehicle).
 - b. Return to step 1.

Overall Function Check

Use this procedure to check the overall function of the heated oxygen sensor 2 circuit. During this check, a 1st trip DTC might not be confirmed.

WITH GST

1. Start engine and warm it up to the normal operating temperature.
2. Turn ignition switch OFF and wait at least 10 seconds.
3. Start engine and keep the engine speed between 3,500 and 4,000 rpm for at least 1 minute under no load.
4. Let engine idle for 1 minute.
5. Set voltmeter probes between ECM terminal 55 [HO2S2 (B1) signal] or 74 [HO2S2 (B2) signal] and ground.

DTC P0139, P0159 HO2S2

[VK45DE]

6. Check the voltage when revving up to 4,000 rpm under no load at least 10 times.
(Depress and release accelerator pedal as soon as possible.)
A change of voltage should be more than 0.06V for 1 second during this procedure.
If the voltage can be confirmed in step 6, step 7 is not necessary.
7. Keep vehicle at idling for 10 minutes, then check the voltage. Or check the voltage when coasting from 80 km/h (50 MPH) in D position with "OD" OFF.
A change of voltage should be more than 0.06V for 1 second during this procedure.
8. If NG, go to [EC-909, "Diagnostic Procedure"](#).

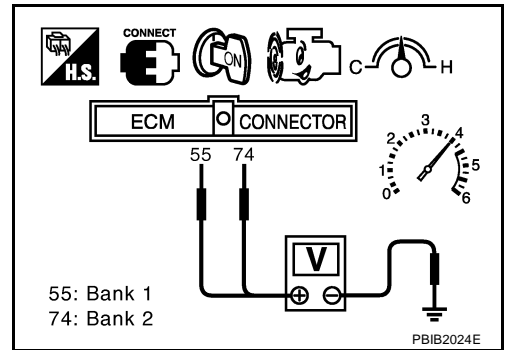

A

EC

C

D

E

F

G

H

I

J

K

L

M

Wiring Diagram
BANK 1

EC-O2S2B1-01

— : DETECTABLE LINE FOR DTC
 — : NON-DETECTABLE LINE FOR DTC

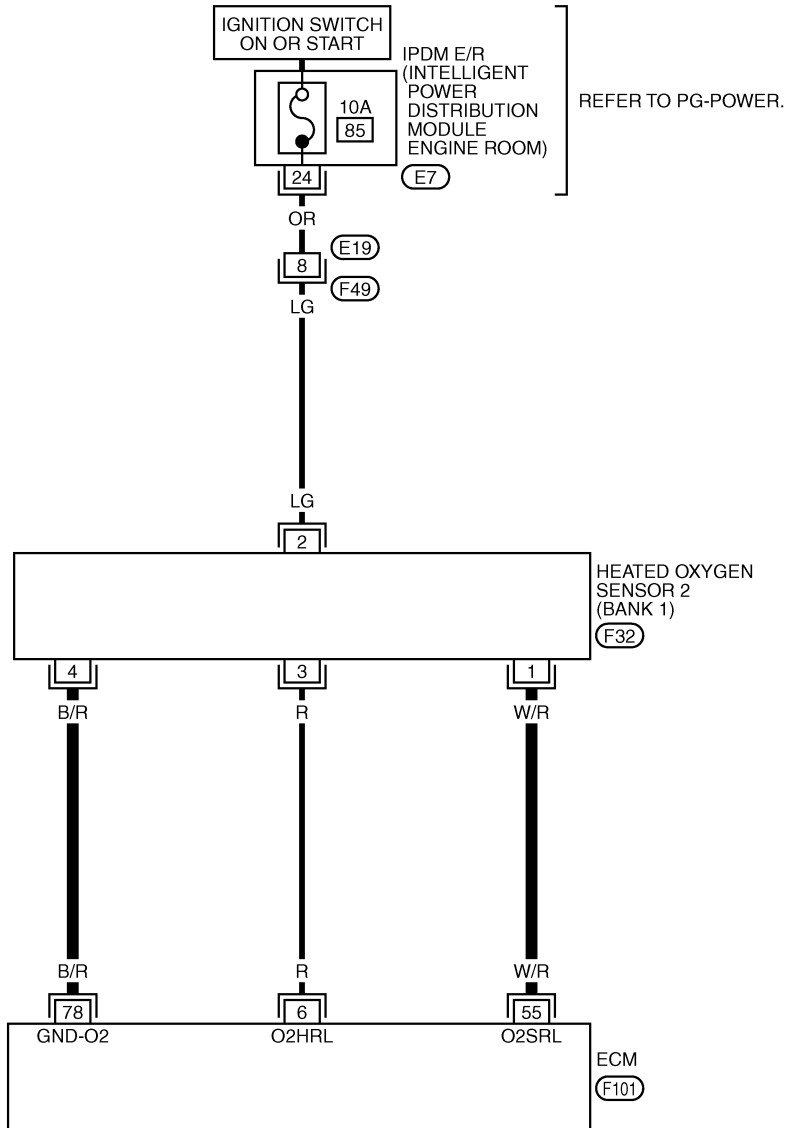

23	22	21	20	19	18	17		
32	31	30	29	28	27	26	25	24

E7
GY



3	1
4	2

F32
GY

1	2	3	4
5	6	7	8

F49
B

4	5	24	23	22	21	20	19	18	17	16	15	14	13	12	11	10	9	8	7	6																			
3	32	31	30	29	28	27	26	25	24	43	42	41	40	39	38	37	36	35	34	33	32	31	30	29	28	27	26	25											
1	2	62	61	60	59	58	57	56	55	54	53	52	51	50	49	48	47	46	45	44	81	80	79	78	77	76	75	74	73	72	71	70	69	68	67	66	65	64	63

F101
B



DTC P0139, P0159 HO2S2

[VK45DE]

Specification data are reference values and are measured between each terminal and ground.

CAUTION:

Do not use ECM ground terminals when measuring input/output voltage. Doing so may result in damage to the ECM's transistor. Use a ground other than ECM terminals, such as the ground.

TER-MINAL NO.	WIRE COLOR	ITEM	CONDITION	DATA (DC Voltage)
55	W/R	Heated oxygen sensor 2 (bank 1)	[Engine is running] <ul style="list-style-type: none"> ● Warm-up condition ● Revving engine from idle to 3,000 rpm quickly after the following conditions are met <ul style="list-style-type: none"> – After keeping the engine speed between 3,500 and 4,000 rpm for 1 minute and at idle for 1 minute under no load 	0 - Approximately 1.0V
78	B/R	Sensor ground (Heated oxygen sensor)	[Engine is running] <ul style="list-style-type: none"> ● Warm-up condition ● Idle speed 	Approximately 0V

A
EC
C
D
E
F
G
H
I
J
K
L
M

BANK 2

EC-O2S2B2-01

— : DETECTABLE LINE FOR DTC
 — : NON-DETECTABLE LINE FOR DTC

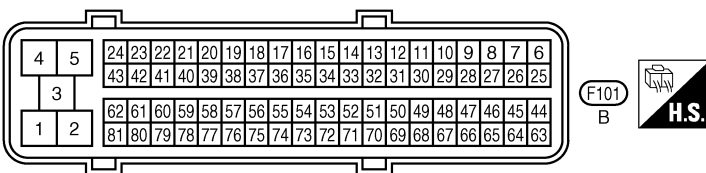
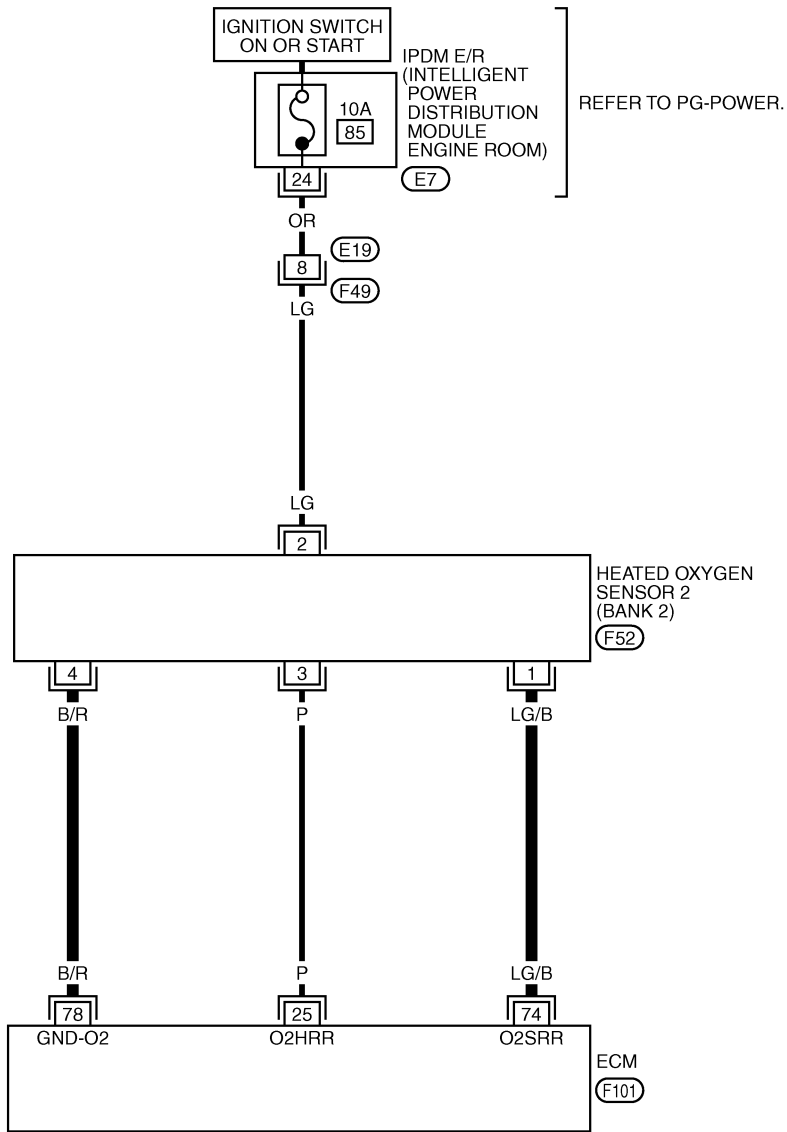

Specification data are reference values and are measured between each terminal and ground.

CAUTION:

Do not use ECM ground terminals when measuring input/output voltage. Doing so may result in damage to the ECM's transistor. Use a ground other than ECM terminals, such as the ground.

TER-MINAL NO.	WIRE COLOR	ITEM	CONDITION	DATA (DC Voltage)
74	LG/B	Heated oxygen sensor 2 (bank 2)	<p>[Engine is running]</p> <ul style="list-style-type: none"> ● Warm-up condition ● Revving engine from idle to 3,000 rpm quickly after the following conditions are met – After keeping the engine speed between 3,500 and 4,000 rpm for 1 minute and at idle for 1 minute under no load 	0 - Approximately 1.0V
78	B/R	Sensor ground (Heated oxygen sensor)	<p>[Engine is running]</p> <ul style="list-style-type: none"> ● Warm-up condition ● Idle speed 	Approximately 0V

Diagnostic Procedure

ABS00C3R

1. CHECK GROUND CONNECTIONS

1. Turn ignition switch OFF.
2. Loosen and retighten three ground screws on the body.
Refer to [EC-791, "Ground Inspection"](#).

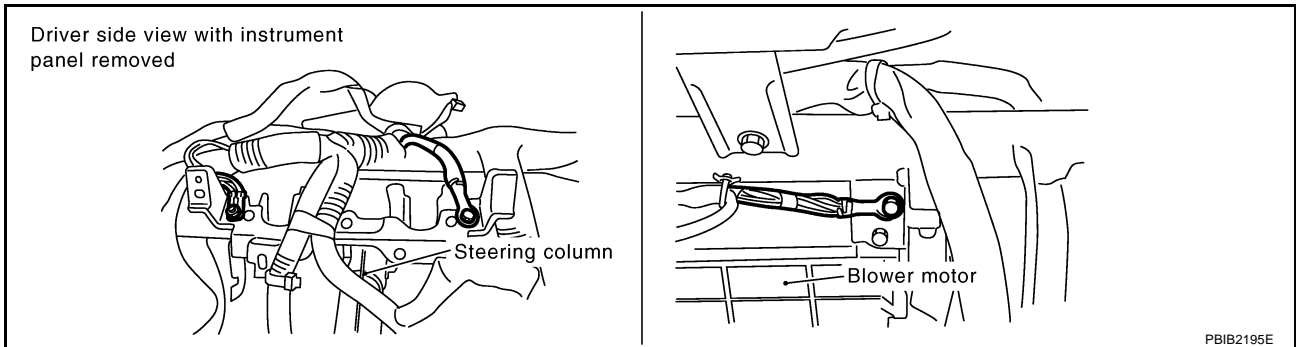

OK or NG

- OK >> GO TO 2.
- NG >> Repair or replace ground connections.

2. CLEAR THE SELF-LEARNING DATA

With CONSULT-II

1. Start engine and warm it up to normal operating temperature.
2. Select "SELF-LEARNING CONT" in "WORK SUPPORT" mode with CONSULT-II.
3. Clear the self-learning control coefficient by touching "CLEAR".
4. Run engine for at least 10 minutes at idle speed.
**Is the 1st trip DTC P0171, P0174 or P0172, P0175 detected?
Is it difficult to start engine?**

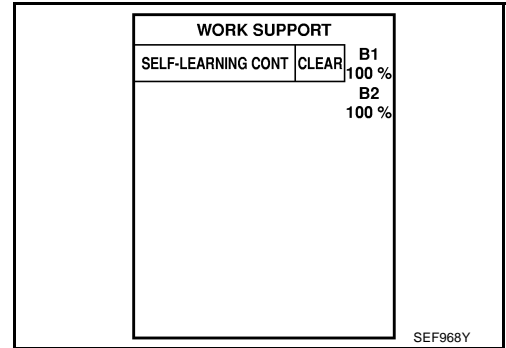

With GST

1. Start engine and warm it up to normal operating temperature.
2. Turn ignition switch OFF.
3. Disconnect mass air flow sensor harness connector, and restart and run engine for at least 5 seconds at idle speed.
4. Stop engine and reconnect mass air flow sensor harness connector.
5. Make sure DTC P0102 is displayed.
6. Erase the DTC memory. Refer to [EC-715, "HOW TO ERASE EMISSION-RELATED DIAGNOSTIC INFORMATION"](#).
7. Make sure DTC P0000 is displayed.
8. Run engine for at least 10 minutes at idle speed.
**Is the 1st trip DTC P0171, P0174 or P0172, P0175 detected?
Is it difficult to start engine?**

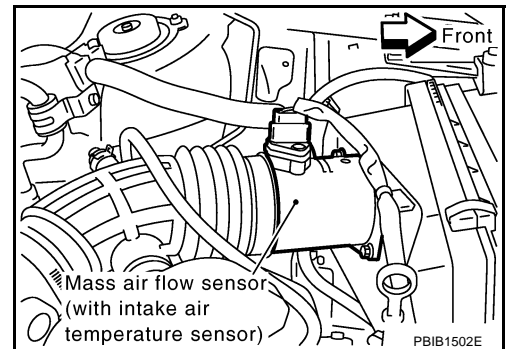

Yes or No

- Yes >> Perform trouble diagnosis for DTC P0171, P0174 or P0172, P0175. Refer to [EC-914](#) or [EC-923](#).
- No >> GO TO 3.

3. CHECK HO2S2 GROUND CIRCUIT FOR OPEN AND SHORT

1. Turn ignition switch OFF.
2. Disconnect heated oxygen sensor 2 harness connector.

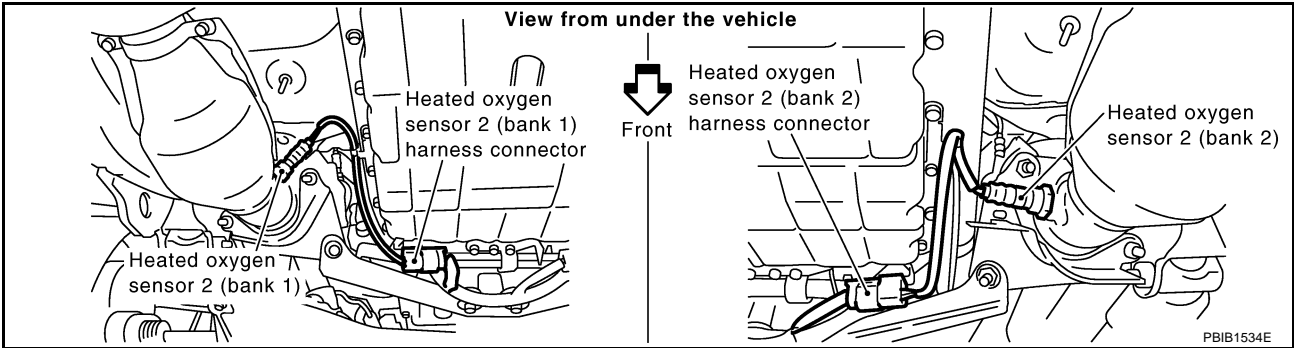

3. Disconnect ECM harness connector.
4. Check harness continuity between HO2S2 terminal 4 and ECM terminal 78. Refer to Wiring Diagram.

Continuity should exist.

5. Also check harness for short to ground and short to power.

OK or NG

OK >> GO TO 4.

NG >> Repair open circuit or short to ground or short to power in harness or connectors.

4. CHECK HO2S2 INPUT SIGNAL CIRCUIT FOR OPEN AND SHORT

1. Check harness continuity between ECM terminal and HO2S2 terminal as follows. Refer to Wiring Diagram.

DTC	Terminals		Bank
	ECM	Sensor	
P0139	55	1	1
P0159	74	1	2

Continuity should exist.

2. Check harness continuity between the following terminals and ground. Refer to Wiring Diagram.

DTC	Terminals		Bank
	ECM	Sensor	
P0139	55	1	1
P0159	74	1	2

Continuity should not exist.

3. Also check harness for short to ground and short to power.

OK or NG

OK >> GO TO 5.

NG >> Repair open circuit or short to ground or short to power in harness or connectors.

5. CHECK HEATED OXYGEN SENSOR 2

Refer to [EC-912, "Component Inspection"](#) .

OK or NG

- OK >> GO TO 6.
- NG >> Replace malfunctioning heated oxygen sensor 2.

6. CHECK INTERMITTENT INCIDENT

Refer to [EC-784, "TROUBLE DIAGNOSIS FOR INTERMITTENT INCIDENT"](#) .

>> INSPECTION END

Component Inspection HEATED OXYGEN SENSOR 2

ABS00C3S

 With CONSULT-II

1. Turn ignition switch ON and select "DATA MONITOR" mode with CONSULT-II.
2. Start engine and warm it up to the normal operating temperature.
3. Turn ignition switch OFF and wait at least 10 seconds.
4. Start engine and keep the engine speed between 3,500 and 4,000 rpm for at least 1 minute under no load.
5. Let engine idle for 1 minute.

DATA MONITOR	
MONITOR	NO DTC
ENG SPEED	XXX rpm
COOLANT TEMP/S	XXX °C

SEF174Y

6. Select "FUEL INJECTION" in "ACTIVE TEST" mode, and select "HO2S2 (B1)/(B2)" as the monitor item with CONSULT-II.

ACTIVE TEST	
FUEL INJECTION	25 %
MONITOR	
ENG SPEED	XXX rpm
HO2S1 (B1)	XXX V
HO2S2 (B1)	XXX V
HO2S1 MNTR (B1)	RICH
HO2S2 MNTR (B1)	RICH

SEF662Y

7. Check "HO2S2 (B1)/(B2)" at idle speed when adjusting "FUEL INJECTION" to $\pm 25\%$.

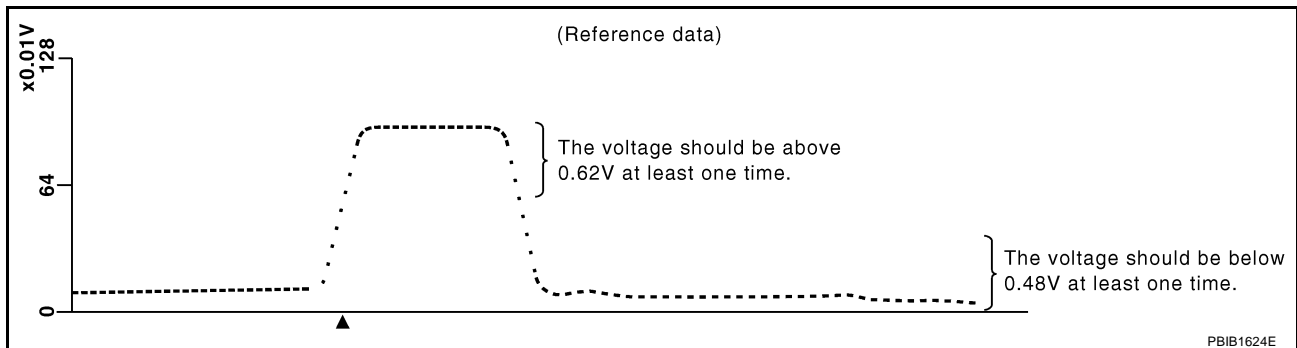

"HO2S2 (B1)/(B2)" should be above 0.62V at least once when the "FUEL INJECTION" is +25%.

"HO2S2 (B1)/(B2)" should be below 0.48V at least once when the "FUEL INJECTION" is -25%.

CAUTION:

- Discard any heated oxygen sensor which has been dropped from a height of more than 0.5 m (19.7 in) onto a hard surface such as a concrete floor; use a new one.

- Before installing new oxygen sensor, clean exhaust system threads using Oxygen Sensor Thread Cleaner tool J-43897-18 or J-43897-12 and approved anti-seize lubricant.

⊗ Without CONSULT-II

1. Start engine and warm it up to the normal operating temperature.
2. Turn ignition switch OFF and wait at least 10 seconds.
3. Start engine and keep the engine speed between 3,500 and 4,000 rpm for at least 1 minute under no load.
4. Let engine idle for 1 minute.
5. Set voltmeter probes between ECM terminal 55 [HO2S2 (B1) signal] or 74 [HO2S2 (B2) signal] and ground.
6. Check the voltage when revving up to 4,000 rpm under no load at least 10 times.
(Depress and release accelerator pedal as soon as possible.)
The voltage should be above 0.62V at least once during this procedure.
If the voltage is above 0.62V at step 6, step 7 is not necessary.
7. Keep vehicle at idling for 10 minutes, then check voltage. Or check the voltage when coasting from 80 km/h (50 MPH) in D position with "OD" OFF.
The voltage should be below 0.48V at least once during this procedure.
8. If NG, replace heated oxygen sensor 2.

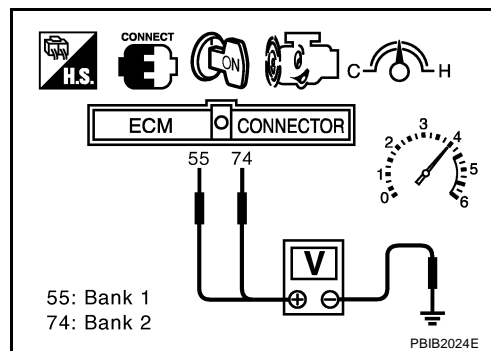

CAUTION:

- Discard any heated oxygen sensor which has been dropped from a height of more than 0.5 m (19.7 in) onto a hard surface such as a concrete floor; use a new one.
- Before installing new oxygen sensor, clean exhaust system threads using Oxygen Sensor Thread Cleaner tool J-43897-18 or J-43897-12 and approved anti-seize lubricant.

Removal and Installation HEATED OXYGEN SENSOR 2

ABS00C3T

Refer to [EM-178, "EXHAUST MANIFOLD AND THREE WAY CATALYST"](#) .

DTC P0171, P0174 FUEL INJECTION SYSTEM FUNCTION

PFP:16600

On Board Diagnosis Logic

ABS00C3U

With the Air-Fuel Mixture Ratio Self-Learning Control, the actual mixture ratio can be brought closely to the theoretical mixture ratio based on the mixture ratio feedback signal from the heated oxygen sensors 1. The ECM calculates the necessary compensation to correct the offset between the actual and the theoretical ratios.

In case the amount of the compensation value is extremely large (the actual mixture ratio is too lean.), the ECM judges the condition as the fuel injection system malfunction and lights up the MIL (2 trip detection logic).

Sensor	Input signal to ECM	ECM function	Actuator
Heated oxygen sensor 1	Density of oxygen in exhaust gas (Mixture ratio feedback signal)	Fuel injection control	Fuel injector

DTC No.	Trouble diagnosis name	DTC detecting condition	Possible cause
P0171 0171 (Bank 1)	Fuel injection system too lean	<ul style="list-style-type: none"> ● Fuel injection system does not operate properly. ● The amount of mixture ratio compensation is too large. (The mixture ratio is too lean.) 	<ul style="list-style-type: none"> ● Intake air leaks ● Heated oxygen sensor 1 ● Fuel injector ● Exhaust gas leaks ● Incorrect fuel pressure ● Lack of fuel ● Mass air flow sensor ● Incorrect PCV hose connection
P0174 0174 (Bank 2)			

DTC Confirmation Procedure

ABS00C3V

NOTE:

If DTC Confirmation Procedure has been previously conducted, always turn ignition switch OFF and wait at least 10 seconds before conducting the next test.

WITH CONSULT-II

1. Start engine and warm it up to normal operating temperature.
2. Turn ignition switch OFF and wait at least 10 seconds.
3. Turn ignition switch ON and select "SELF-LEARNING CONT" in "WORK SUPPORT" mode with CONSULT-II.
4. Clear the self-learning control coefficient by touching "CLEAR".
5. Select "DATA MONITOR" mode with CONSULT-II.
6. Start engine again and let it idle for at least 10 minutes. The 1st trip DTC P0171 or P0174 should be detected at this stage, if a malfunction exists. If so, go to [EC-918, "Diagnostic Procedure"](#).
7. If it is difficult to start engine at step 6, the fuel injection system has a malfunction, too.
8. Crank engine while depressing accelerator pedal. If engine starts, go to [EC-918, "Diagnostic Procedure"](#). If engine does not start, check exhaust and intake air leak visually.

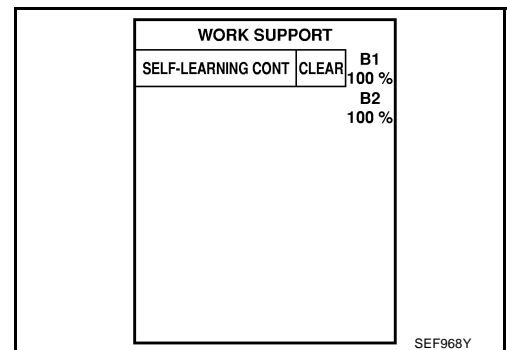

WITH GST

1. Start engine and warm it up to normal operating temperature.
2. Turn ignition switch OFF and wait at least 10 seconds.
3. Disconnect mass air flow sensor harness connector. Then restart and run engine for at least 5 seconds at idle speed.
4. Stop engine and reconnect mass air flow sensor harness connector.
5. Select MODE 3 with GST. Make sure DTC P0102 is detected.
6. Select MODE 4 with GST and erase the DTC P0102.
7. Start engine again and let it idle for at least 10 minutes.
8. Select MODE 7 with GST. The 1st trip DTC P0171 or P0174 should be detected at this stage, if a malfunction exists. If so, go to [EC-918, "Diagnostic Procedure"](#).
9. If it is difficult to start engine at step 7, the fuel injection system has a malfunction.
10. Crank engine while depressing accelerator pedal. If engine starts, go to [EC-918, "Diagnostic Procedure"](#). If engine does not start, check exhaust and intake air leak visually.

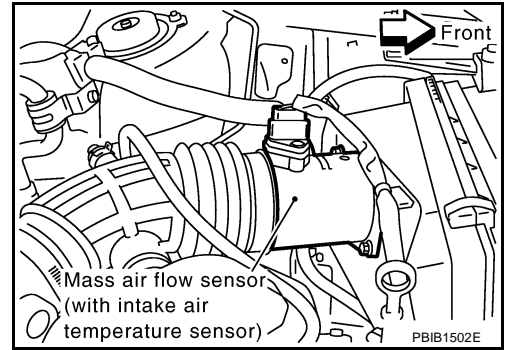

A
EC
C
D
E
F
G
H
I
J
K
L
M

DTC P0171, P0174 FUEL INJECTION SYSTEM FUNCTION

[VK45DE]

ABS00C3W

Wiring Diagram BANK 1

EC-FUELB1-01

— : DETECTABLE LINE FOR DTC
- - - : NON-DETECTABLE LINE FOR DTC

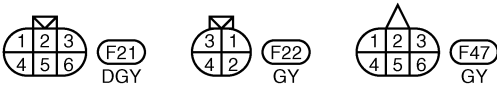
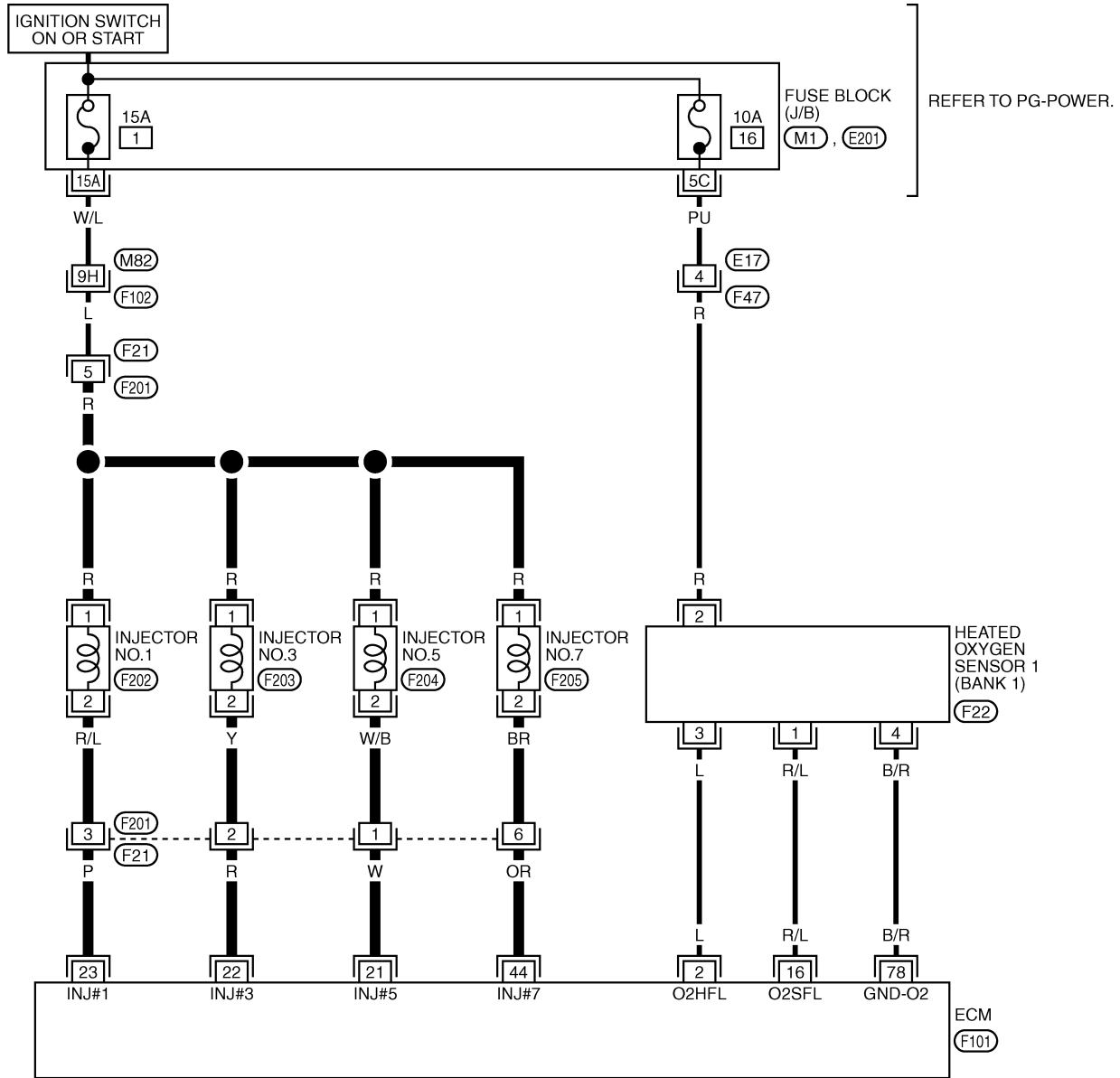

REFER TO THE FOLLOWING.

(F102) -SUPER MULTIPLE JUNCTION (SMJ)
(M1), (E201) -FUSE BLOCK-JUNCTION BOX (J/B)

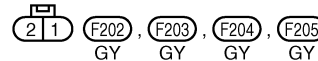
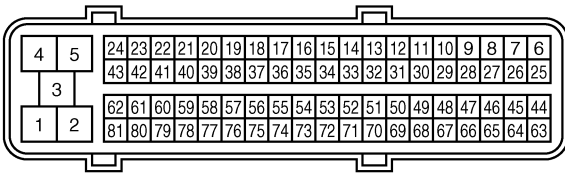

TBWM0232E

DTC P0171, P0174 FUEL INJECTION SYSTEM FUNCTION

[VK45DE]

BANK 2

EC-FUELB2-01

— : DETECTABLE LINE FOR DTC
 - - - : NON-DETECTABLE LINE FOR DTC

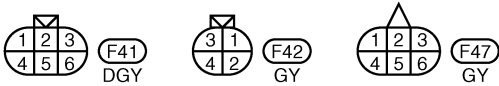
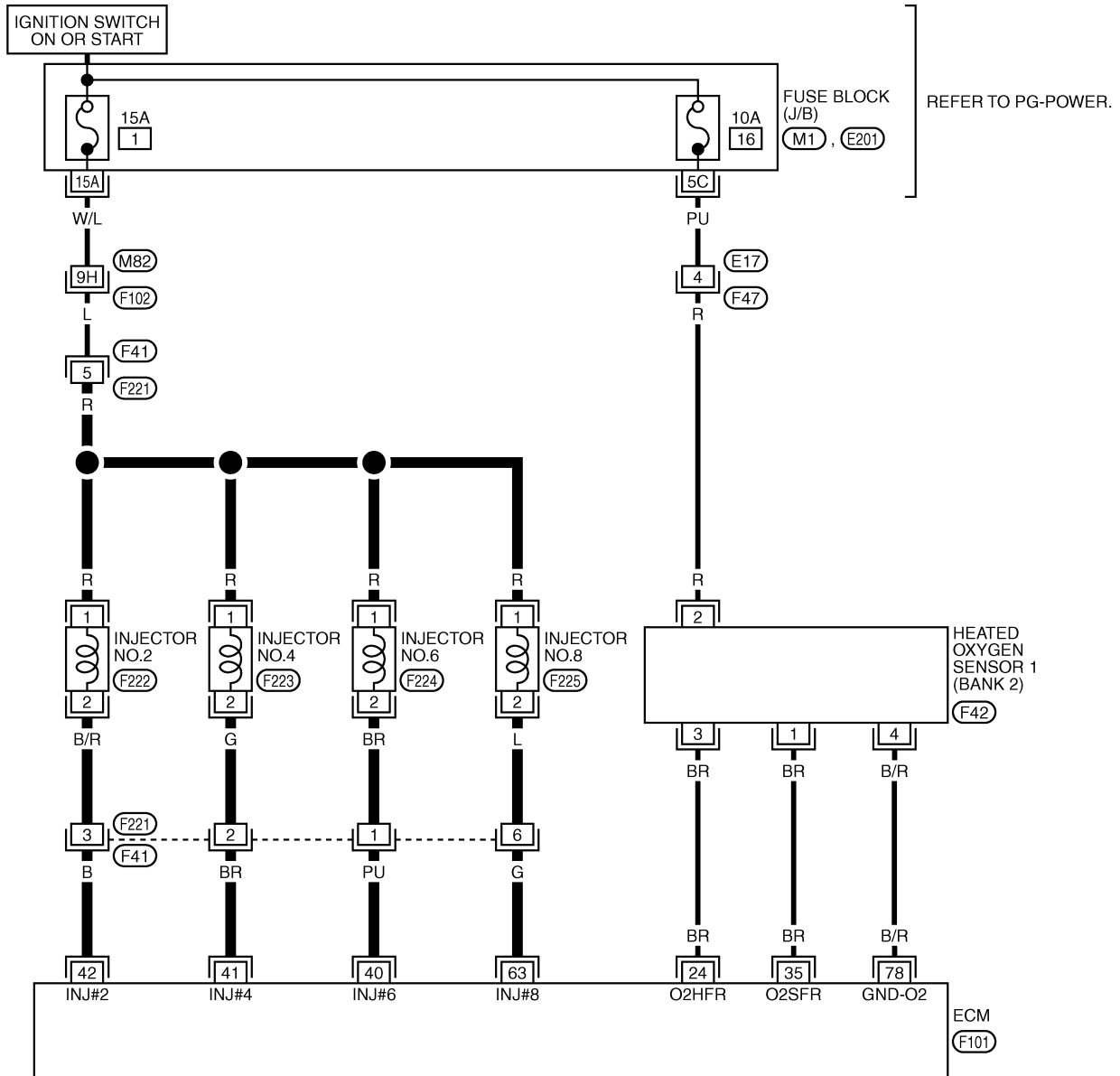

REFER TO THE FOLLOWING.
 (F102) -SUPER MULTIPLE JUNCTION (SMJ)
 (M1), (E201) -FUSE BLOCK-JUNCTION BOX (J/B)

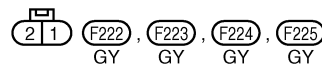
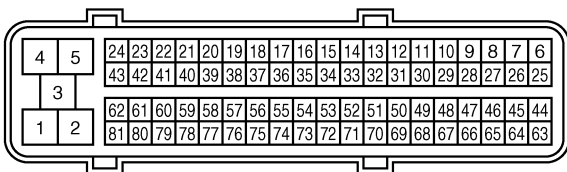

TBWM0233E

Diagnostic Procedure**1. CHECK EXHAUST GAS LEAK**

1. Start engine and run it at idle.
2. Listen for an exhaust gas leak before three way catalyst (manifold).

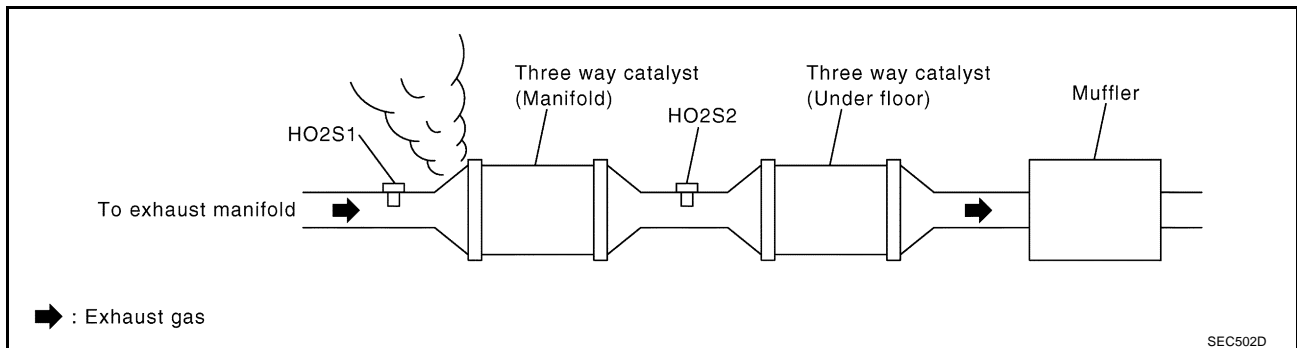
**OK or NG**

- OK >> GO TO 2.
 NG >> Repair or replace.

2. CHECK FOR INTAKE AIR LEAK

1. Listen for an intake air leak after the mass air flow sensor.
2. Check PCV hose connection.

OK or NG

- OK >> GO TO 3.
 NG >> Repair or replace.

3. CHECK HEATED OXYGEN SENSOR 1 CIRCUIT FOR OPEN AND SHORT

1. Turn ignition switch OFF.
2. Disconnect corresponding heated oxygen sensor 1 (HO2S1) harness connector.

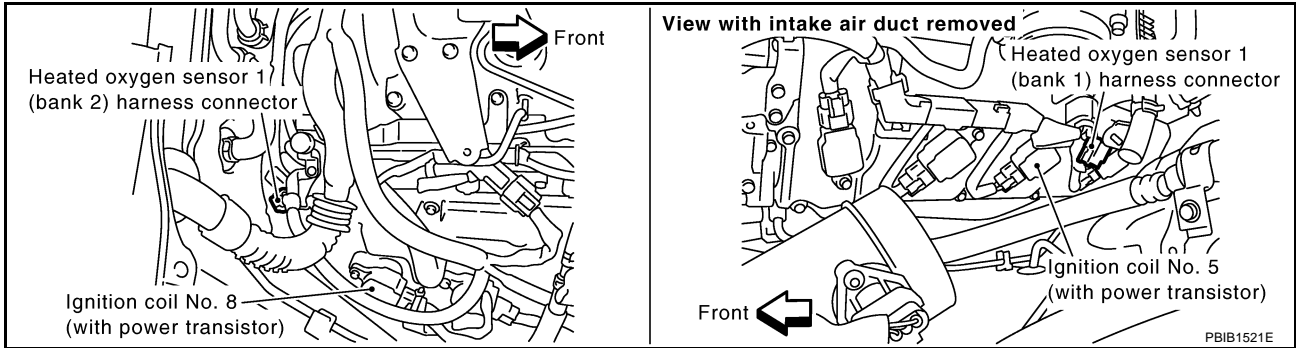

3. Disconnect ECM harness connector.
4. Check harness continuity between ECM terminal and HO2S1 terminal as follows. Refer to Wiring Diagram.

DTC	Terminals		Bank
	ECM	Sensor	
P0171	16	1	1
P0174	35	1	2

Continuity should exist.

5. Check harness continuity between the following terminals and ground. Refer to Wiring Diagram.

DTC	Terminals		Bank
	ECM	Sensor	
P0171	16	1	1
P0174	35	1	2

Continuity should not exist.

6. Check harness continuity between HO2S1 terminal 4 and ECM terminal 78.

Continuity should exist.

7. Also check harness for short to ground and short to power.

OK or NG

OK >> GO TO 4.

NG >> Repair open circuit or short to ground or short to power in harness or connectors.

4. CHECK FUEL PRESSURE

1. Release fuel pressure to zero. Refer to [EC-700, "FUEL PRESSURE RELEASE"](#) .
2. Install fuel pressure gauge and check fuel pressure. Refer to [EC-701, "FUEL PRESSURE CHECK"](#) .

At idling: 350 kPa (3.57 kg/cm² , 51 psi)

OK or NG

OK >> GO TO 6.

NG >> GO TO 5.

5. DETECT MALFUNCTIONING PART

Check the following.

- Fuel pump and circuit (Refer to [EC-1280](#) .)
- Fuel pressure regulator (Refer to [EC-701](#) .)
- Fuel lines
- Fuel filter for clogging

>> Repair or replace.

6. CHECK MASS AIR FLOW SENSOR

With CONSULT-II

1. Install all removed parts.
2. Check "MASS AIR FLOW" in "DATA MONITOR" mode with CONSULT-II.

2.0 - 6.0 g-m/sec: at idling

7.0 - 20.0 g-m/sec: at 2,500 rpm

With GST

1. Install all removed parts.
2. Check mass air flow sensor signal in MODE 1 with GST.

2.0 - 6.0 g-m/sec: at idling

7.0 - 20.0 g-m/sec: at 2,500 rpm

OK or NG

OK >> GO TO 8.

NG >> Check connectors for rusted terminals or loose connections in the mass air flow sensor circuit or ground. Refer to [EC-822, "DTC P0101 MAF SENSOR"](#) .

7. CHECK FUNCTION OF INJECTORS

With CONSULT-II

1. Start engine.
2. Perform "POWER BALANCE" in "ACTIVE TEST" mode with CONSULT-II.
3. Make sure that each circuit produces a momentary engine speed drop.

ACTIVE TEST	
POWER BALANCE	
MONITOR	
ENG SPEED	XXX rpm
MAS A/F SE-B1	XXX V

PBIB0133E

Without CONSULT-II

1. Start engine.
2. Listen to each injector operating sound.

Clicking noise should be heard.

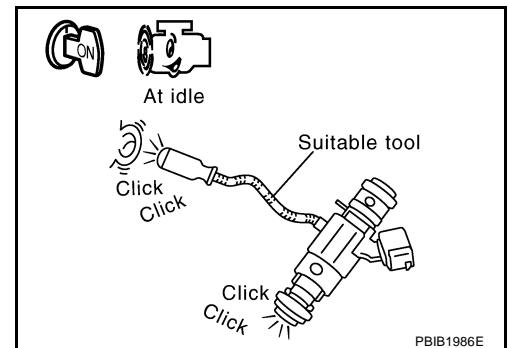

OK or NG

OK >> GO TO 8.

NG >> Perform trouble diagnosis for [EC-1274, "INJECTOR CIRCUIT"](#) .

8. CHECK INJECTOR

1. Confirm that the engine is cooled down and there are no fire hazards near the vehicle.
2. Turn ignition switch OFF.
3. Disconnect all injector harness connectors.
4. Remove injector gallery assembly. Refer to [EM-188, "FUEL INJECTOR AND FUEL TUBE"](#) . Keep fuel hose and all injectors connected to injector gallery.
5. For DTC P0171, reconnect injector harness connectors on bank 1.
For DTC P0174, reconnect injector harness connectors on bank 2.
6. Disconnect all ignition coil harness connectors.
7. Prepare pans or saucers under each injector.
8. Crank engine for about 3 seconds.
For DTC P0171, make sure that fuel sprays out from injectors on bank 1.
For DTC P0174, make sure that fuel sprays out from injectors on bank 2.

Fuel should be sprayed evenly for each injector.

OK or NG

OK >> GO TO 9.

NG >> Replace injectors from which fuel does not spray out.
Always replace O-ring with new ones.

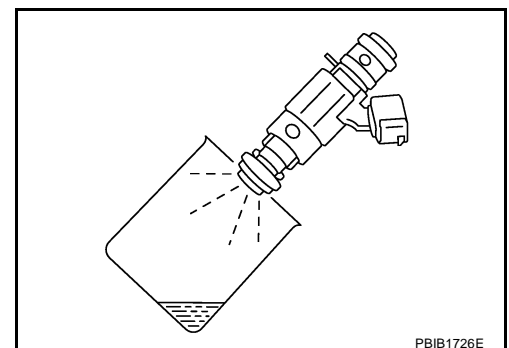

9. CHECK INTERMITTENT INCIDENT

Refer to [EC-784, "TROUBLE DIAGNOSIS FOR INTERMITTENT INCIDENT"](#) .

>> INSPECTION END

DTC P0172, P0175 FUEL INJECTION SYSTEM FUNCTION

PFP:16600

On Board Diagnosis Logic

ABS00C3Y

With the Air-Fuel Mixture Ratio Self-Learning Control, the actual mixture ratio can be brought closely to the theoretical mixture ratio based on the mixture ratio feedback signal from the heated oxygen sensors 1. The ECM calculates the necessary compensation to correct the offset between the actual and the theoretical ratios.

In case the amount of the compensation value is extremely large (the actual mixture ratio is too rich.), the ECM judges the condition as the fuel injection system malfunction and lights up the MIL (2 trip detection logic).

Sensor	Input signal to ECM	ECM function	Actuator
Heated oxygen sensor 1	Density of oxygen in exhaust gas (Mixture ratio feedback signal)	Fuel injection control	Fuel injector

DTC No.	Trouble diagnosis name	DTC detecting condition	Possible cause
P0172 0172 (Bank 1)	Fuel injection system too rich	<ul style="list-style-type: none"> ● Fuel injection system does not operate properly. ● The amount of mixture ratio compensation is too large. (The mixture ratio is too rich.) 	<ul style="list-style-type: none"> ● Heated oxygen sensor 1 ● Fuel injector ● Exhaust gas leaks ● Incorrect fuel pressure ● Mass air flow sensor
P0175 0175 (Bank 2)			

DTC Confirmation Procedure

ABS00C3Z

NOTE:

If DTC Confirmation Procedure has been previously conducted, always turn ignition switch OFF and wait at least 10 seconds before conducting the next test.

WITH CONSULT-II

1. Start engine and warm it up to normal operating temperature.
2. Turn ignition switch OFF and wait at least 10 seconds.
3. Turn ignition switch ON and select "SELF-LEARNING CONT" in "WORK SUPPORT" mode with CONSULT-II.
4. Clear the self-learning control coefficient by touching "CLEAR".
5. Select "DATA MONITOR" mode with CONSULT-II.
6. Start engine again and let it idle for at least 10 minutes.
The 1st trip DTC P0172 or P0175 should be detected at this stage, if a malfunction exists. If so, go to [EC-927, "Diagnostic Procedure"](#).
7. If it is difficult to start engine at step 6, the fuel injection system has a malfunction, too.
8. Crank engine while depressing accelerator pedal.
If engine starts, go to [EC-927, "Diagnostic Procedure"](#).
If engine does not start, remove ignition plugs and check for fouling, etc.

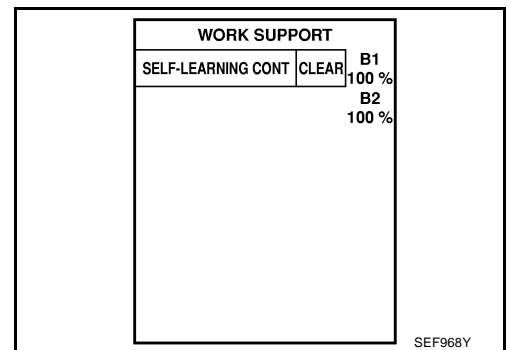

WITH GST

1. Start engine and warm it up to normal operating temperature.
2. Turn ignition switch OFF and wait at least 10 seconds.
3. Disconnect mass air flow sensor harness connector. Then restart and run engine for at least 5 seconds at idle speed.
4. Stop engine and reconnect mass air flow sensor harness connector.
5. Select MODE 3 with GST. Make sure DTC P0102 is detected.
6. Select MODE 4 with GST and erase the DTC P0102.
7. Start engine again and let it idle for at least 10 minutes.
8. Select MODE 7 with GST. The 1st trip DTC P0172 or P0175 should be detected at this stage, if a malfunction exists. If so, go to [EC-927, "Diagnostic Procedure"](#) .
9. If it is difficult to start engine at step 7, the fuel injection system has a malfunction.
10. Crank engine while depressing accelerator pedal.
If engine starts, go to [EC-927, "Diagnostic Procedure"](#) . If engine does not start, remove ignition plugs and check for fouling, etc.

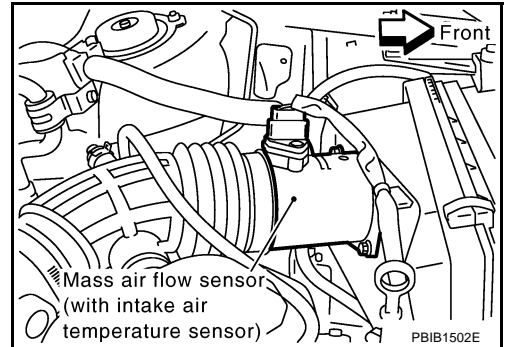

DTC P0172, P0175 FUEL INJECTION SYSTEM FUNCTION

[VK45DE]

ABS00C40

Wiring Diagram BANK 1

EC-FUELB1-01

— : DETECTABLE LINE FOR DTC
- - - : NON-DETECTABLE LINE FOR DTC

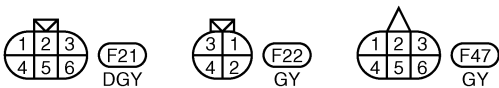
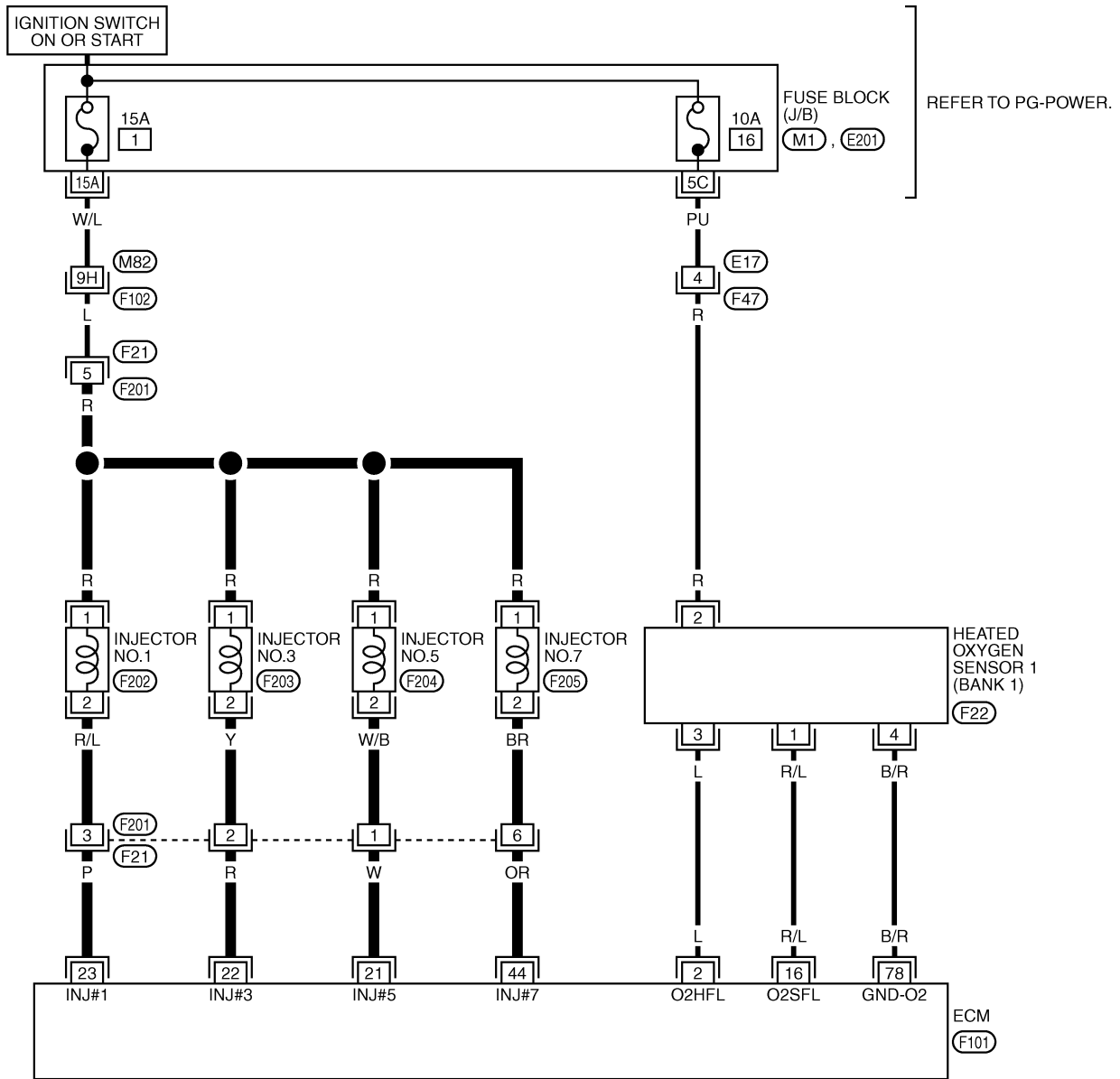

REFER TO THE FOLLOWING.

(F102) -SUPER MULTIPLE JUNCTION (SMJ)
(M1), (E201) -FUSE BLOCK-JUNCTION BOX (J/B)

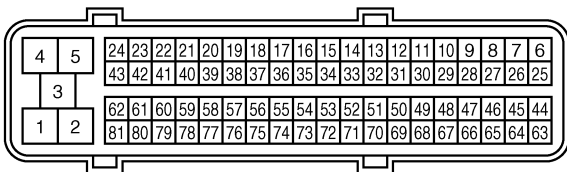

(F101) B

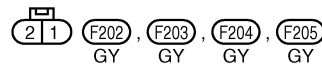

TBWM0232E

DTC P0172, P0175 FUEL INJECTION SYSTEM FUNCTION

[VK45DE]

BANK 2

EC-FUELB2-01

— : DETECTABLE LINE FOR DTC
 — : NON-DETECTABLE LINE FOR DTC

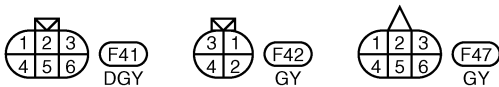
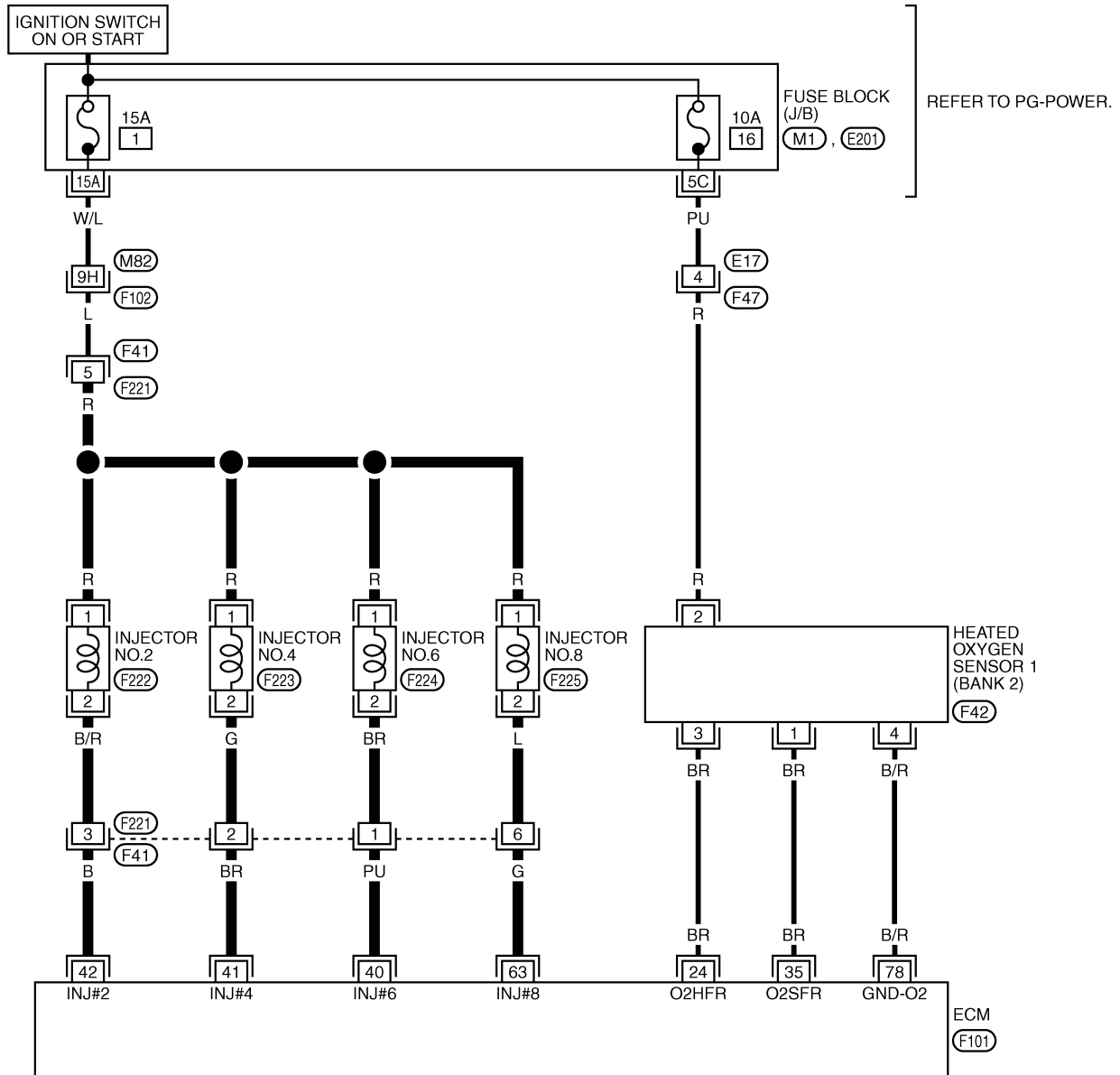

REFER TO THE FOLLOWING.
 (F102) -SUPER MULTIPLE JUNCTION (SMJ)
 (M1), (E201) -FUSE BLOCK-JUNCTION BOX (J/B)

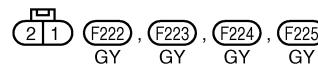
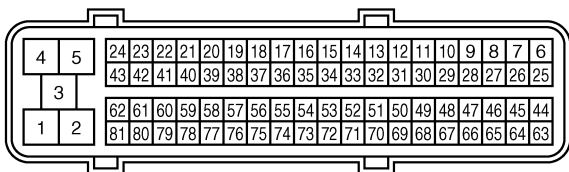

TBWM0233E

Diagnostic Procedure

1. CHECK EXHAUST GAS LEAK

1. Start engine and run it at idle.
2. Listen for an exhaust gas leak before three way catalyst (manifold).

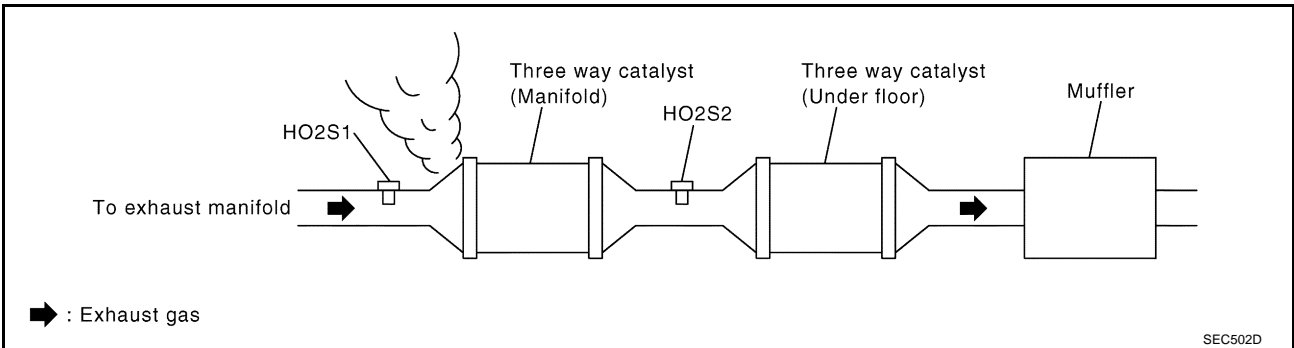

OK or NG

- OK >> GO TO 2.
- NG >> Repair or replace.

2. CHECK FOR INTAKE AIR LEAK

Listen for an intake air leak after the mass air flow sensor.

OK or NG

- OK >> GO TO 3.
- NG >> Repair or replace.

A
EC
C
D
E
F
G
H
I
J
K
L
M

3. CHECK HEATED OXYGEN SENSOR 1 CIRCUIT FOR OPEN AND SHORT

1. Turn ignition switch OFF.
2. Disconnect corresponding heated oxygen sensor 1 (HO2S1) harness connector.

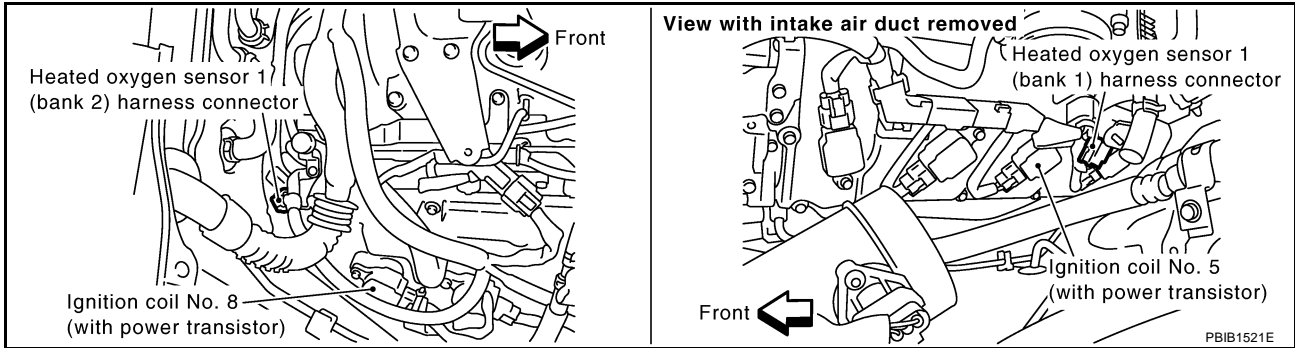

3. Disconnect ECM harness connector.
4. Check harness continuity between ECM terminal and HO2S1 terminal as follows. Refer to Wiring Diagram.

DTC	Terminals		Bank
	ECM	Sensor	
P0172	16	1	1
P0175	35	1	2

Continuity should exist.

5. Check harness continuity between the following terminals and ground. Refer to Wiring Diagram.

DTC	Terminals		Bank
	ECM	Sensor	
P0172	16	1	1
P0175	35	1	2

Continuity should not exist.

6. Check harness continuity between HO2S1 terminal 4 and ECM terminal 78.

Continuity should exist.

7. Also check harness for short to ground and short to power.

OK or NG

OK >> GO TO 4.

NG >> Repair open circuit or short to ground or short to power in harness or connectors.

4. CHECK FUEL PRESSURE

1. Release fuel pressure to zero. Refer to [EC-700, "FUEL PRESSURE RELEASE"](#).
2. Install fuel pressure gauge and check fuel pressure. Refer to [EC-701, "FUEL PRESSURE CHECK"](#).

At idling: 350 kPa (3.57 kg/cm² , 51 psi)

OK or NG

OK >> GO TO 6.

NG >> GO TO 5.

5. DETECT MALFUNCTIONING PART

Check the following.

- Fuel pump and circuit (Refer to, [EC-1280](#) .)
- Fuel pressure regulator (Refer to [EC-701](#) .)

>> Repair or replace.

6. CHECK MASS AIR FLOW SENSOR**🔧 With CONSULT-II**

1. Install all removed parts.
2. Check "MASS AIR FLOW" in "DATA MONITOR" mode with CONSULT-II.

2.0 - 6.0 g-m/sec: at idling

7.0 - 20.0 g-m/sec: at 2,500 rpm

🔧 With GST

1. Install all removed parts.
2. Check mass air flow sensor signal in MODE 1 with GST.

2.0 - 6.0 g-m/sec: at idling

7.0 - 20.0 g-m/sec: at 2,500 rpm

OK or NG

OK >> GO TO 7.

NG >> Check connectors for rusted terminals or loose connections in the mass air flow sensor circuit or ground. Refer to [EC-822, "DTC P0101 MAF SENSOR"](#) .

A

EC

C

D

E

F

G

H

I

J

K

L

M

7. CHECK FUNCTION OF INJECTORS

④ With CONSULT-II

1. Start engine.
2. Perform "POWER BALANCE" in "ACTIVE TEST" mode with CONSULT-II.
3. Make sure that each circuit produces a momentary engine speed drop.

ACTIVE TEST	
POWER BALANCE	
MONITOR	
ENG SPEED	XXX rpm
MAS A/F SE-B1	XXX V

PBIB0133E

⊗ Without CONSULT-II

1. Start engine.
2. Listen to each injector operating sound.

Clicking noise should be heard.

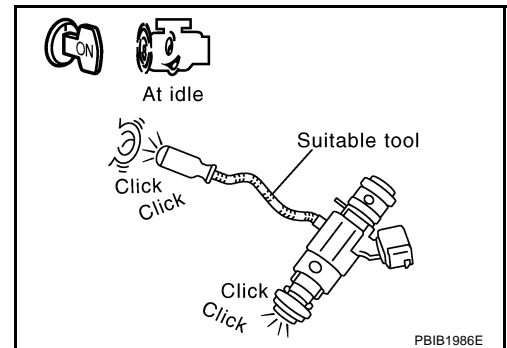

OK or NG

OK >> GO TO 8.

NG >> Perform trouble diagnosis for [EC-1274, "INJECTOR CIRCUIT"](#) .

8. CHECK INJECTOR

1. Remove injector assembly. Refer to [EM-188, "FUEL INJECTOR AND FUEL TUBE"](#) .
Keep fuel hose and all injectors connected to injector gallery.
2. Confirm that the engine is cooled down and there are no fire hazards near the vehicle.
3. Disconnect all injector harness connectors.
4. Disconnect all ignition coil harness connectors.
5. Prepare pans or saucers under each injectors.
6. Crank engine for about 3 seconds.
Make sure fuel does not drip from injector.

OK or NG

OK (Does not drip.)>>GO TO 9.

NG (Drips.)>>Replace the injectors from which fuel is dripping. Always replace O-ring with new one.

9. CHECK INTERMITTENT INCIDENT

Refer to [EC-784, "TROUBLE DIAGNOSIS FOR INTERMITTENT INCIDENT"](#) .

>> INSPECTION END

DTC P0181 FTT SENSOR

PFP:22630

Component Description

ABS00C42

The fuel tank temperature sensor is used to detect the fuel temperature inside the fuel tank. The sensor modifies a voltage signal from the ECM. The modified signal returns to the ECM as the fuel temperature input. The sensor uses a thermistor which is sensitive to the change in temperature. The electrical resistance of the thermistor decreases as temperature increases.

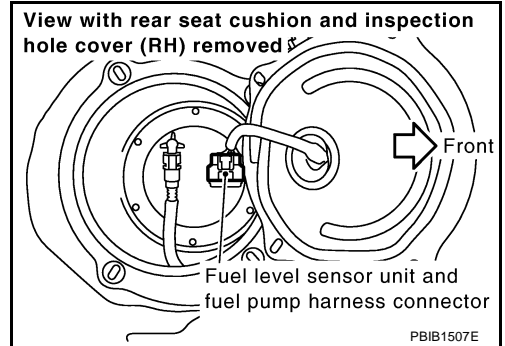

<Reference data>

Fluid temperature °C (°F)	Voltage* V	Resistance kΩ
20 (68)	3.5	2.3 - 2.7
50 (122)	2.2	0.79 - 0.90

*: These data are reference values and are measured between ECM terminal 107 (Fuel tank temperature sensor) and ground.

CAUTION:

Do not use ECM ground terminals when measuring input/output voltage. Doing so may result in damage to the ECM's transistor. Use a ground other than ECM terminals, such as the ground.

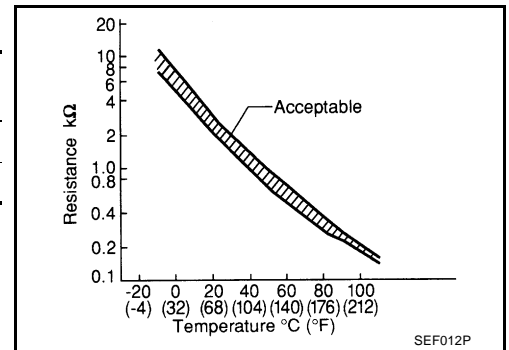

On Board Diagnosis Logic

ABS00C43

DTC No.	Trouble diagnosis name	DTC detecting condition	Possible cause
P0181 0181	Fuel tank temperature sensor circuit range/performance	Rationally incorrect voltage from the sensor is sent to ECM, compared with the voltage signals from engine coolant temperature sensor and intake air temperature sensor.	<ul style="list-style-type: none"> ● Harness or connectors (The sensor circuit is open or shorted) ● Fuel tank temperature sensor

DTC Confirmation Procedure

ABS00C44

NOTE:

If DTC Confirmation Procedure has been previously conducted, always turn ignition switch OFF and wait at least 10 seconds before conducting the next test.

WITH CONSULT-II

1. Turn ignition switch ON.
2. Select "DATA MONITOR" mode with CONSULT-II.
3. Wait at least 10 seconds.
If the result is NG, go to [EC-934, "Diagnostic Procedure"](#).
If the result is OK, go to following step.
4. Check "COOLAN TEMP/S" value.
If "COOLAN TEMP/S" is less than 60°C (140°F), the result will be OK.
If "COOLAN TEMP/S" is above 60°C (140°F), go to the following step.
5. Cool engine down until "COOLAN TEMP/S" is less than 60°C (140°F).
6. Wait at least 10 seconds.
7. If 1st trip DTC is detected, go to [EC-934, "Diagnostic Procedure"](#).

DATA MONITOR	
MONITOR	NO DTC
ENG SPEED	XXX rpm
COOLAN TEMP/S	XXX °C

SEF174Y

 **WITH GST**

Follow the procedure "WITH CONSULT-II" above.

DTC P0181 FTT SENSOR

[VK45DE]

Wiring Diagram

ABS00C45

EC-FTTS-01

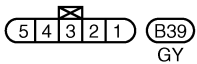
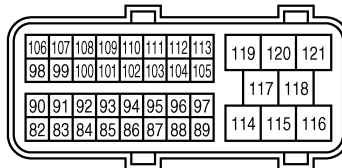
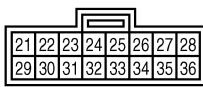
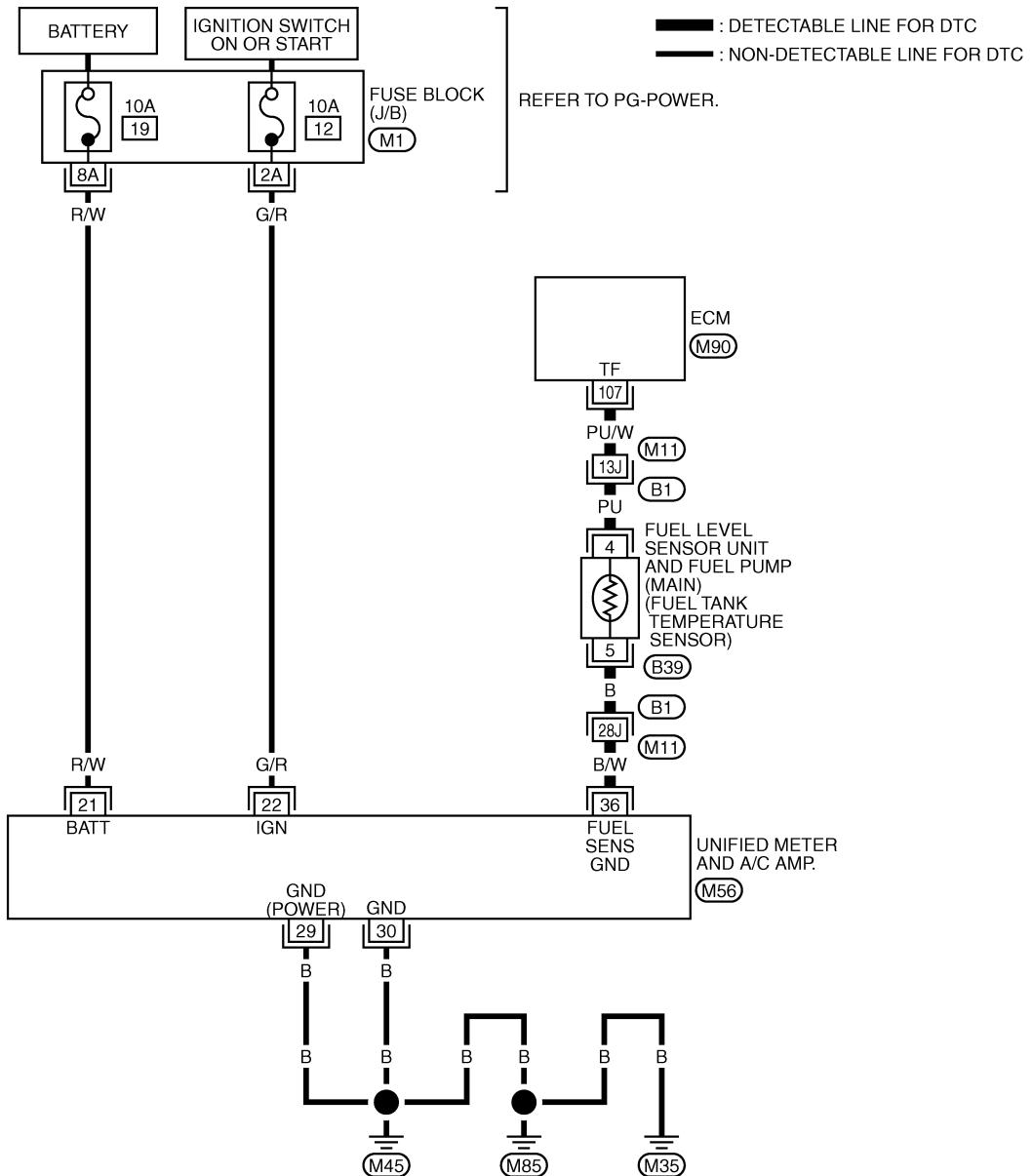

REFER TO THE FOLLOWING.

(B1) -SUPER MULTIPLE JUNCTION (SMJ)

(M1) -FUSE BLOCK-JUNCTION BOX (J/B)

TBWH0109E

Diagnostic Procedure

1. CHECK GROUND CONNECTIONS

1. Turn ignition switch OFF.
2. Loosen and retighten three ground screws on the body.
Refer to [EC-791, "Ground Inspection"](#).

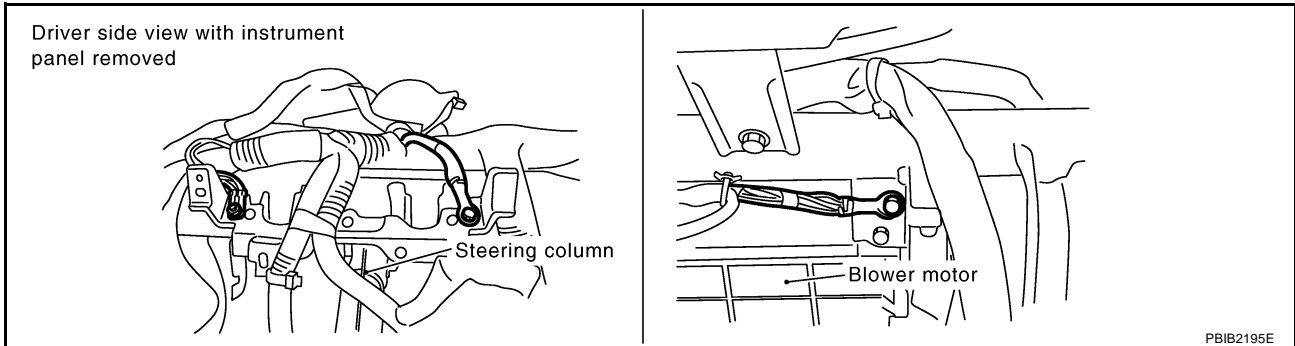

OK or NG

- OK >> GO TO 2.
- NG >> Repair or replace ground connections.

2. CHECK DTC WITH "UNIFIED METER AND A/C AMP."

Refer to [DI-32, "SELF-DIAGNOSTIC RESULTS"](#).

OK or NG

- OK >> GO TO 3.
- NG >> Go to [DI-20, "Fuel Level Sensor Signal Inspection 1"](#).

3. CHECK FUEL TANK TEMPERATURE SENSOR POWER SUPPLY CIRCUIT

1. Turn ignition switch OFF.
2. Disconnect "fuel level sensor unit and fuel pump" harness connector.
3. Turn ignition switch ON.

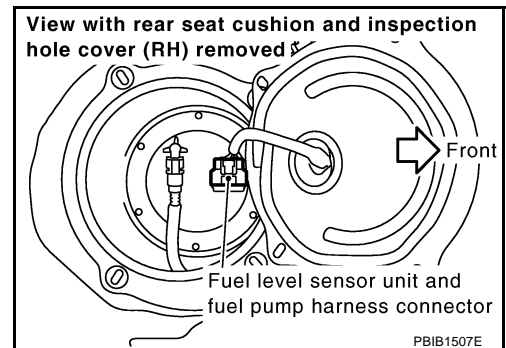

4. Check voltage between "fuel level sensor unit and fuel pump" terminal 4 and ground with CONSULT-II or tester.

Voltage: Approximately 5V

OK or NG

- OK >> GO TO 5.
- NG >> GO TO 4.

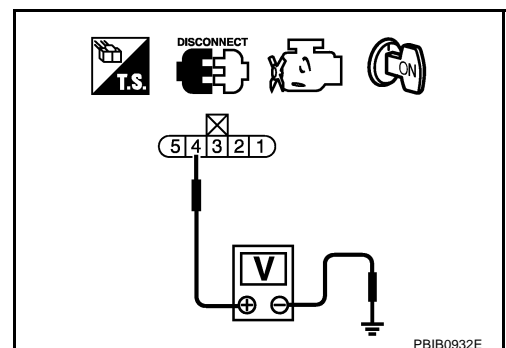

4. DETECT MALFUNCTIONING PART

Check the following.

- Harness connectors B1, M11
- Harness for open or short between ECM and “fuel level sensor unit and fuel pump”

>> Repair open circuit or short to ground or short to power in harness or connector.

5. CHECK FUEL TANK TEMPERATURE SENSOR GROUND CIRCUIT FOR OPEN AND SHORT

1. Turn ignition switch OFF.
2. Disconnect “unified meter and A/C amp.” harness connector.
3. Check harness continuity between “fuel level sensor unit and fuel pump” terminal 5 and “unified meter and A/C amp.” terminal 36. Refer to Wiring Diagram.

Continuity should exist.

4. Also check harness for short to ground and short to power.

OK or NG

- OK >> GO TO 7.
- NG >> GO TO 6.

6. DETECT MALFUNCTIONING PART

Check the following.

- Harness connectors B1, M11
- Harness for open or short between “fuel level sensor unit and fuel pump” and “unified meter and A/C amp.”

>> Repair open circuit or short to power in harness or connector.

7. CHECK FUEL TANK TEMPERATURE SENSOR

Refer to [EC-936, "Component Inspection"](#) .

OK or NG

- OK >> GO TO 8.
- NG >> Replace fuel level sensor unit.

8. CHECK INTERMITTENT INCIDENT

Refer to [EC-784, "TROUBLE DIAGNOSIS FOR INTERMITTENT INCIDENT"](#) .

>> **INSPECTION END**

Component Inspection

FUEL TANK TEMPERATURE SENSOR

1. Remove fuel level sensor unit.
2. Check resistance between "fuel level sensor unit and fuel pump" terminals 4 and 5 by heating with hot water or heat gun as shown in the figure.

Temperature °C (°F)	Resistance kΩ
20 (68)	2.3 - 2.7
50 (122)	0.79 - 0.90

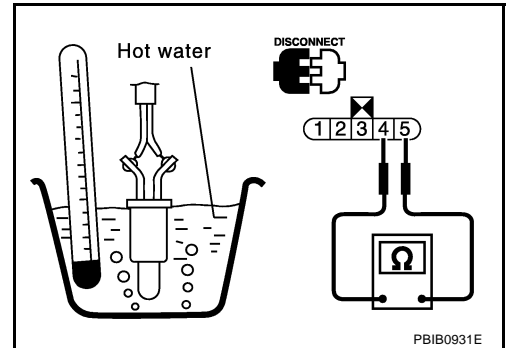

Removal and Installation

FUEL TANK TEMPERATURE SENSOR

Refer to [FL-4, "FUEL LEVEL SENSOR UNIT, FUEL FILTER AND FUEL PUMP ASSEMBLY"](#) .

DTC P0182, P0183 FTT SENSOR

PFP:22630

Component Description

ABS00C49

The fuel tank temperature sensor is used to detect the fuel temperature inside the fuel tank. The sensor modifies a voltage signal from the ECM. The modified signal returns to the ECM as the fuel temperature input. The sensor uses a thermistor which is sensitive to the change in temperature. The electrical resistance of the thermistor decreases as temperature increases.

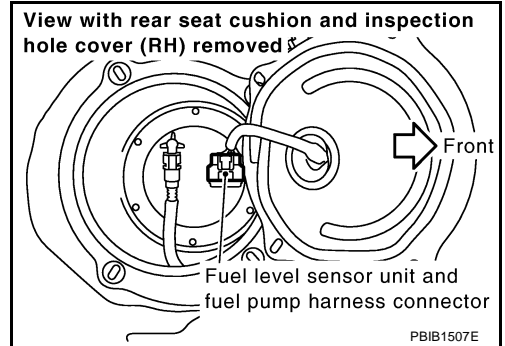

<Reference data>

Fluid temperature °C (°F)	Voltage* V	Resistance kΩ
20 (68)	3.5	2.3 - 2.7
50 (122)	2.2	0.79 - 0.90

*: These data are reference values and are measured between ECM terminal 107 (Fuel tank temperature sensor) and ground.

CAUTION:

Do not use ECM ground terminals when measuring input/output voltage. Doing so may result in damage to the ECM's transistor. Use a ground other than ECM terminals, such as the ground.

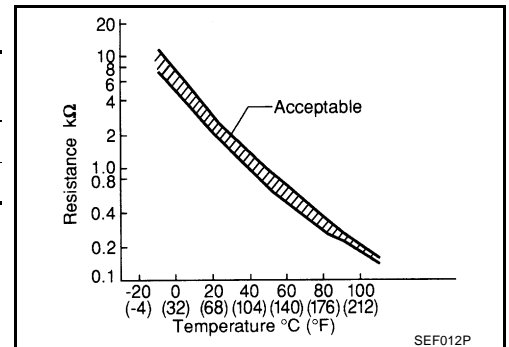

On Board Diagnosis Logic

ABS00C4A

DTC No.	Trouble diagnosis name	DTC detecting condition	Possible cause
P0182 0182	Fuel tank temperature sensor circuit low input	An excessively low voltage from the sensor is sent to ECM.	<ul style="list-style-type: none"> ● Harness or connectors (The sensor circuit is open or shorted.) ● Fuel tank temperature sensor
P0183 0183	Fuel tank temperature sensor circuit high input	An excessively high voltage from the sensor is sent to ECM.	

DTC Confirmation Procedure

ABS00C4B

NOTE:

If DTC Confirmation Procedure has been previously conducted, always turn ignition switch OFF and wait at least 10 seconds before conducting the next test.

WITH CONSULT-II

1. Turn ignition switch ON.
2. Select "DATA MONITOR" mode with CONSULT-II.
3. Wait at least 5 seconds.
4. If 1st trip DTC is detected, go to [EC-939, "Diagnostic Procedure"](#)

DATA MONITOR	
MONITOR	NO DTC
ENG SPEED	XXX rpm
COOLAN TEMP/S	XXX °C

SEF174Y

WITH GST

Follow the procedure "WITH CONSULT-II" above.

DTC P0182, P0183 FTT SENSOR

[VK45DE]

ABS00C4C

Wiring Diagram

EC-FTTS-01

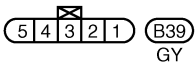
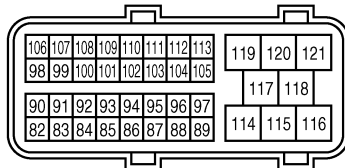
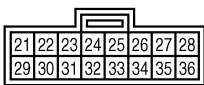
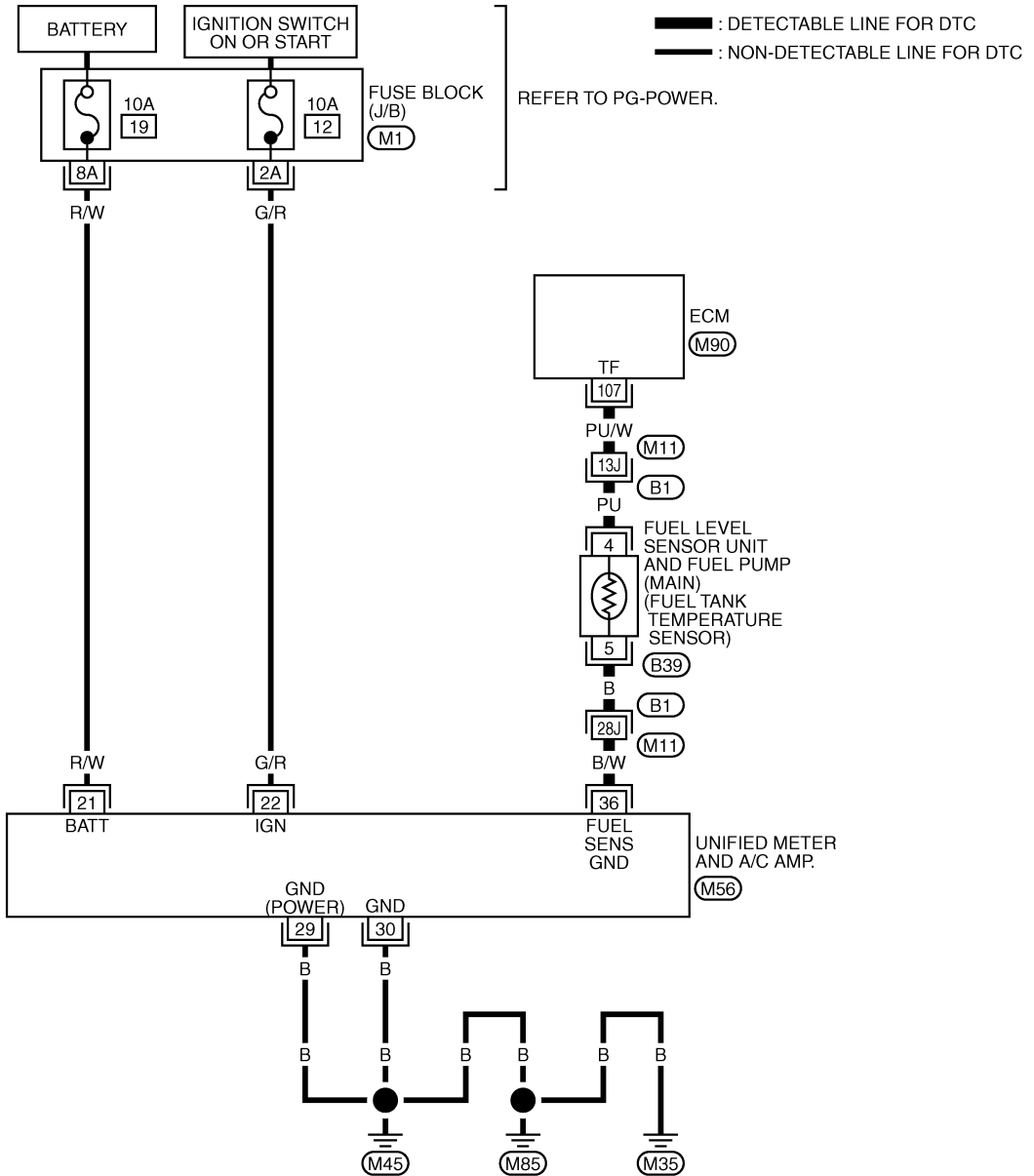

REFER TO THE FOLLOWING.

(B1) -SUPER MULTIPLE JUNCTION (SMJ)

(M1) -FUSE BLOCK-JUNCTION BOX (J/B)

TBWH0109E

Diagnostic Procedure

1. CHECK GROUND CONNECTIONS

1. Turn ignition switch OFF.
2. Loosen and retighten three ground screws on the body.
Refer to [EC-791, "Ground Inspection"](#) .

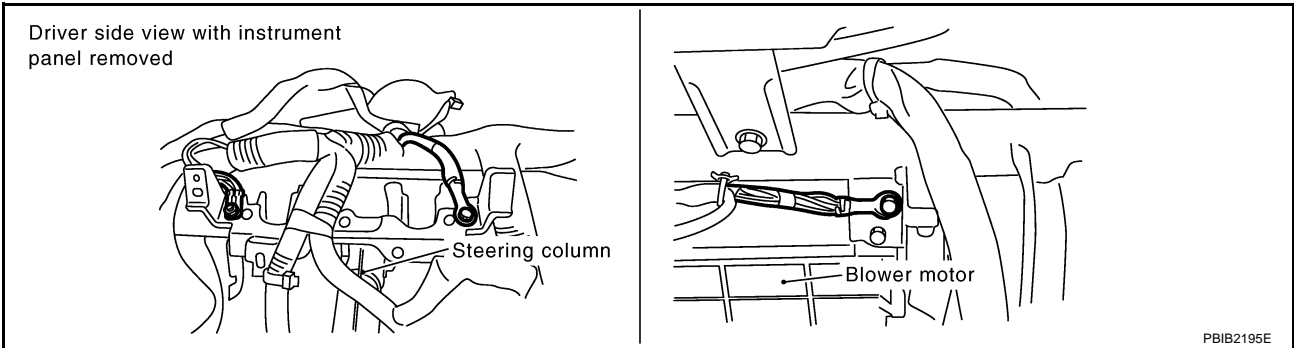

OK or NG

- OK >> GO TO 2.
- NG >> Repair or replace ground connections.

2. CHECK DTC WITH "UNIFIED METER AND A/C AMP."

Refer to [DI-32, "SELF-DIAGNOSTIC RESULTS"](#) .

OK or NG

- OK >> GO TO 3.
- NG >> Go to [DI-20, "Fuel Level Sensor Signal Inspection 1"](#) .

3. CHECK FUEL TANK TEMPERATURE SENSOR POWER SUPPLY CIRCUIT

1. Turn ignition switch OFF.
2. Disconnect "fuel level sensor unit and fuel pump" harness connector.
3. Turn ignition switch ON.

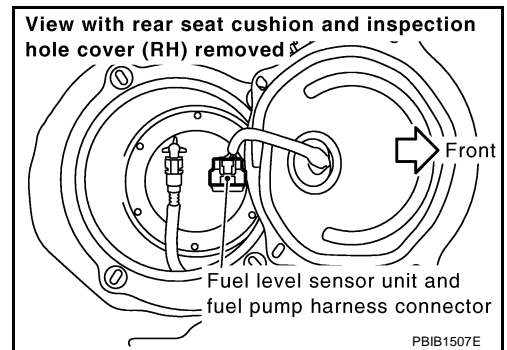

4. Check voltage between "fuel level sensor unit and fuel pump" terminal 4 and ground with CONSULT-II or tester.

Voltage: Approximately 5V

OK or NG

- OK >> GO TO 5.
- NG >> GO TO 4.

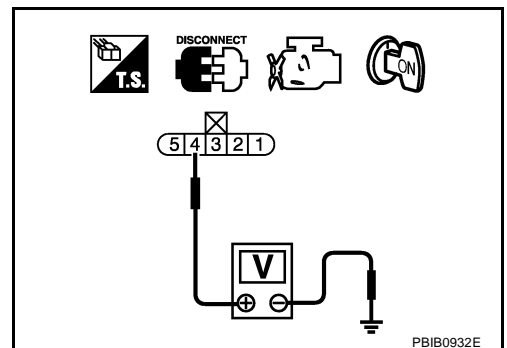

4. DETECT MALFUNCTIONING PART

Check the following.

- Harness connectors B1, M11
- Harness for open or short between ECM and “fuel level sensor unit and fuel pump”

>> Repair open circuit or short to ground or short to power in harness or connector.

5. CHECK FUEL TANK TEMPERATURE SENSOR GROUND CIRCUIT FOR OPEN AND SHORT

1. Turn ignition switch OFF.
2. Disconnect “unified meter and A/C amp.” harness connector.
3. Check harness continuity between “fuel level sensor unit and fuel pump” terminal 5 and “unified meter and A/C amp.” terminal 36. Refer to Wiring Diagram.

Continuity should exist.

4. Also check harness for short to ground and short to power.

OK or NG

- OK >> GO TO 7.
NG >> GO TO 6.

6. DETECT MALFUNCTIONING PART

Check the following.

- Harness connectors B1, M11
- Harness for open or short between “fuel level sensor unit and fuel pump” and “unified meter and A/C amp.”

>> Repair open circuit or short to power in harness or connector.

7. CHECK FUEL TANK TEMPERATURE SENSOR

Refer to [EC-936, "Component Inspection"](#) .

OK or NG

- OK >> GO TO 8.
NG >> Replace fuel level sensor unit.

8. CHECK INTERMITTENT INCIDENT

Refer to [EC-784, "TROUBLE DIAGNOSIS FOR INTERMITTENT INCIDENT"](#) .

>> **INSPECTION END**

Component Inspection FUEL TANK TEMPERATURE SENSOR

1. Remove fuel level sensor unit.
2. Check resistance between "fuel level sensor unit and fuel pump" terminals 4 and 5 by heating with hot water or heat gun as shown in the figure.

Temperature °C (°F)	Resistance kΩ
20 (68)	2.3 - 2.7
50 (122)	0.79 - 0.90

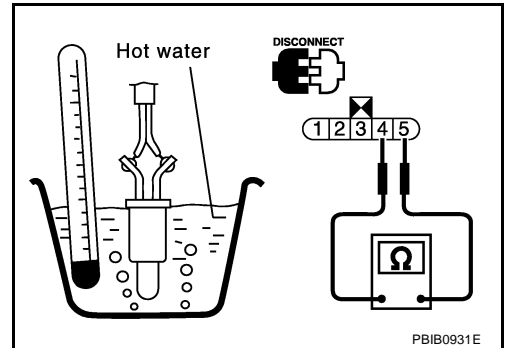

PBIB0931E

Removal and Installation FUEL TANK TEMPERATURE SENSOR

Refer to [FL-4, "FUEL LEVEL SENSOR UNIT, FUEL FILTER AND FUEL PUMP ASSEMBLY"](#) .

DTC P0222, P0223 TP SENSOR

PFP:16119

Component Description

ABS00C4G

Electric throttle control actuator consists of throttle control motor, throttle position sensor, etc. The throttle position sensor responds to the throttle valve movement.

The throttle position sensor has the two sensors. These sensors are a kind of potentiometers which transform the throttle valve position into output voltage, and emit the voltage signal to the ECM. In addition, these sensors detect the opening and closing speed of the throttle valve and feed the voltage signals to the ECM. The ECM judges the current opening angle of the throttle valve from these signals and the ECM controls the throttle control motor to make the throttle valve opening angle properly in response to driving condition.

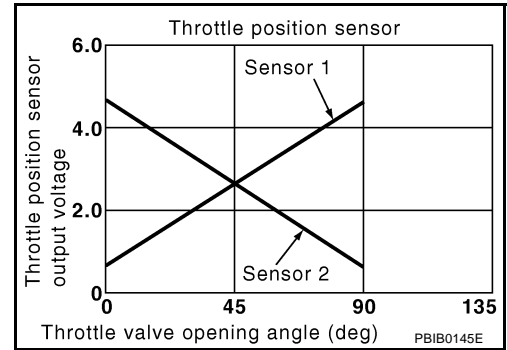

CONSULT-II Reference Value in Data Monitor Mode

ABS00C4H

Specification data are reference values.

MONITOR ITEM	CONDITION		SPECIFICATION
THRTL SEN1 THRTL SEN2*	<ul style="list-style-type: none"> Ignition switch: ON (Engine stopped) Shift lever: D 	Accelerator pedal: Fully released	More than 0.36V
		Accelerator pedal: Fully depressed	Less than 4.75V

*: Throttle position sensor 2 signal is converted by ECM internally. Thus, it differs from ECM terminal voltage signal.

On Board Diagnosis Logic

ABS00C4I

These self-diagnoses have the one trip detection logic.

DTC No.	Trouble diagnosis name	DTC detecting condition	Possible cause
P0222 0222	Throttle position sensor 1 circuit low input	An excessively low voltage from the TP sensor 1 is sent to ECM.	<ul style="list-style-type: none"> Harness or connectors (TP sensor 1 circuit is open or shorted.) (APP sensor 2 circuit is shorted.) Electric throttle control actuator (TP sensor 1) Accelerator pedal position sensor
P0223 0223	Throttle position sensor 1 circuit high input	An excessively high voltage from the TP sensor 1 is sent to ECM.	

FAIL-SAFE MODE

When the malfunction is detected, ECM enters fail-safe mode and the MIL lights up.

Engine operation condition in fail-safe mode

The ECM controls the electric throttle control actuator in regulating the throttle opening in order for the idle position to be within +10 degrees.

The ECM regulates the opening speed of the throttle valve to be slower than the normal condition.

So, the acceleration will be poor.

DTC Confirmation Procedure

NOTE:

If DTC Confirmation Procedure has been previously conducted, always turn ignition switch OFF and wait at least 10 seconds before conducting the next test.

TESTING CONDITION:

Before performing the following procedure, confirm that battery voltage is more than 10V at idle.

WITH CONSULT-II

1. Turn ignition switch ON.
2. Select "DATA MONITOR" mode with CONSULT-II.
3. Start engine and let it idle for 1 second.
4. If DTC is detected, go to [EC-945, "Diagnostic Procedure"](#) .

DATA MONITOR	
MONITOR	NO DTC
ENG SPEED	XXX rpm
<small>SEF058Y</small>	

WITH GST

Follow the procedure "WITH CONSULT-II" above.

A
EC
C
D
E
F
G
H
I
J
K
L
M

DTC P0222, P0223 TP SENSOR

[VK45DE]

ABS00C4K

Wiring Diagram

EC-TPS1-01

: DETECTABLE LINE FOR DTC
 : NON-DETECTABLE LINE FOR DTC

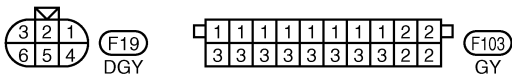
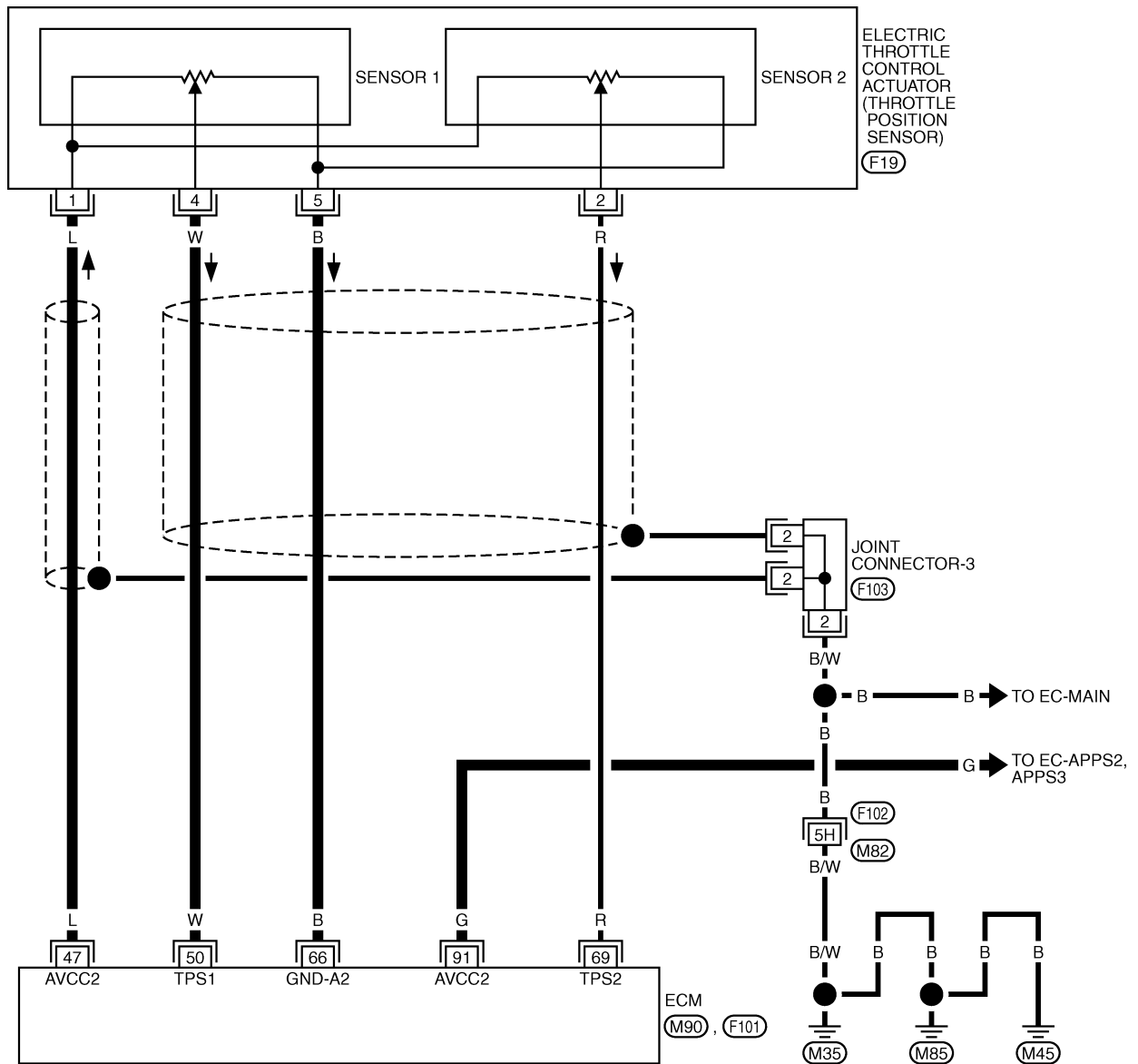

REFER TO THE FOLLOWING.

(F102) -SUPER MULTIPLE JUNCTION (SMJ)

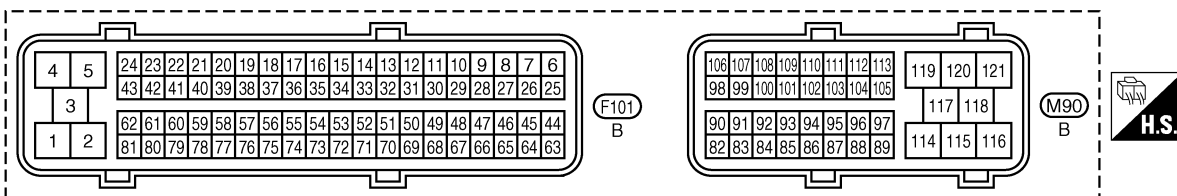

TBWM0428E

DTC P0222, P0223 TP SENSOR

[VK45DE]

Specification data are reference values and are measured between each terminal and ground.

CAUTION:

Do not use ECM ground terminals when measuring input/output voltage. Doing so may result in damage to the ECM's transistor. Use a ground other than ECM terminals, such as the ground.

TER-MINAL NO.	WIRE COLOR	ITEM	CONDITION	DATA (DC Voltage)
47	L	Sensor power supply (Throttle position sensor)	[Ignition switch: ON]	Approximately 5V
50	W	Throttle position sensor 1	[Ignition switch: ON] ● Engine stopped ● Shift lever: D ● Accelerator pedal is fully released	More than 0.36V
			[Ignition switch: ON] ● Engine stopped ● Shift lever: D ● Accelerator pedal is fully depressed	Less than 4.75V
66	B	Sensor ground (Throttle position sensor)	[Engine is running] ● Warm-up condition ● Idle speed	Approximately 0V
69	R	Throttle position sensor 2	[Ignition switch: ON] ● Engine stopped ● Shift lever: D ● Accelerator pedal is fully released	Less than 4.75V
			[Ignition switch: ON] ● Engine stopped ● Shift lever: D ● Accelerator pedal is fully depressed	More than 0.36V
91	G	Sensor power supply (APP sensor 2)	[Ignition switch: ON]	Approximately 5V

Diagnostic Procedure

ABS00C4L

1. CHECK GROUND CONNECTIONS

1. Turn ignition switch OFF.
2. Loosen and retighten three ground screws on the body.
Refer to [EC-791, "Ground Inspection"](#) .

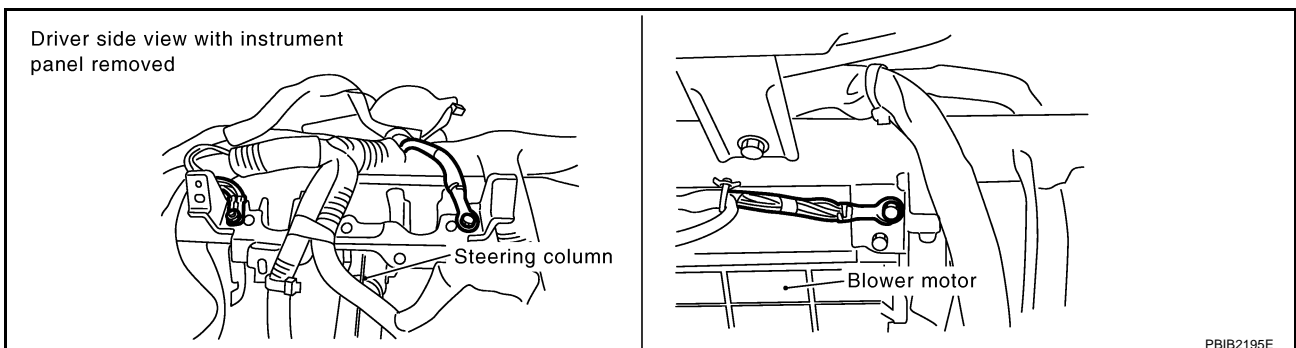

PBIB2195E

OK or NG

- OK >> GO TO 2.
- NG >> Repair or replace ground connections.

2. CHECK THROTTLE POSITION SENSOR 1 POWER SUPPLY CIRCUIT-I

1. Disconnect electric throttle control actuator harness connector.
2. Turn ignition switch ON.

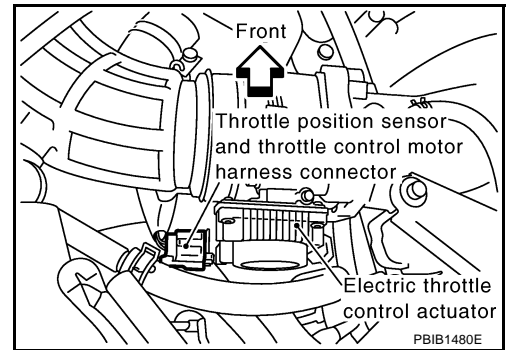

3. Check voltage between electric throttle control actuator terminal 1 and ground with CONSULT-II or tester.

Voltage: Approximately 5V

OK or NG

- OK >> GO TO 7.
 NG >> GO TO 3.

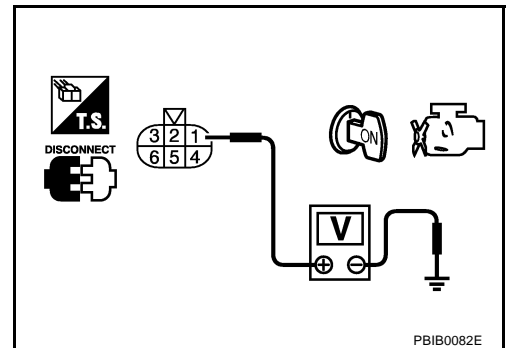

3. CHECK THROTTLE POSITION SENSOR 1 POWER SUPPLY CIRCUIT-II

1. Turn ignition switch OFF.
2. Disconnect ECM harness connector.
3. Check harness continuity between electric throttle control actuator terminal 1 and ECM terminal 47. Refer to Wiring Diagram.

Continuity should exist.

OK or NG

- OK >> GO TO 4.
 NG >> Repair or replace open circuit.

4. CHECK THROTTLE POSITION SENSOR 1 POWER SUPPLY CIRCUIT-III

Check harness for short to power and short to ground, between the following terminals.

ECM terminal	Sensor terminal	Reference Wiring Diagram
47	Electric throttle control actuator terminal 1	EC-850
91	APP sensor terminal 4	EC-1234

OK or NG

- OK >> GO TO 5.
 NG >> Repair short to ground or short to power in harness or connectors.

5. CHECK APP SENSOR

Refer to [EC-1238, "Component Inspection"](#).

OK or NG

- OK >> GO TO 11.
 NG >> GO TO 6.

6. REPLACE ACCELERATOR PEDAL ASSEMBLY

1. Replace accelerator pedal assembly.
2. Perform [EC-698, "Accelerator Pedal Released Position Learning"](#) .
3. Perform [EC-698, "Throttle Valve Closed Position Learning"](#) .
4. Perform [EC-698, "Idle Air Volume Learning"](#) .

>> INSPECTION END

7. CHECK THROTTLE POSITION SENSOR 1 GROUND CIRCUIT FOR OPEN AND SHORT

1. Turn ignition switch OFF.
2. Disconnect ECM harness connector.
3. Check harness continuity between electric throttle control actuator terminal 5 and ECM terminal 66.
Refer to Wiring Diagram.

Continuity should exist.

4. Also check harness for short to ground and short to power.

OK or NG

OK >> GO TO 8.

NG >> Repair open circuit or short to ground or short to power in harness or connectors.

8. CHECK THROTTLE POSITION SENSOR 1 INPUT SIGNAL CIRCUIT FOR OPEN AND SHORT

1. Check harness continuity between electric throttle control actuator terminal 4 and ECM terminal 50.
Refer to Wiring Diagram.

Continuity should exist.

2. Also check harness for short to ground and short to power.

OK or NG

OK >> GO TO 9.

NG >> Repair open circuit or short to ground or short to power in harness or connectors.

9. CHECK THROTTLE POSITION SENSOR

Refer to [EC-854, "Component Inspection"](#) .

OK or NG

OK >> GO TO 11.

NG >> GO TO 10.

10. REPLACE ELECTRIC THROTTLE CONTROL ACTUATOR

1. Replace the electric throttle control actuator.
2. Perform [EC-698, "Throttle Valve Closed Position Learning"](#) .
3. Perform [EC-698, "Idle Air Volume Learning"](#) .

>> INSPECTION END

11. CHECK INTERMITTENT INCIDENT

Refer to [EC-784, "TROUBLE DIAGNOSIS FOR INTERMITTENT INCIDENT"](#) .

>> INSPECTION END

Component Inspection
THROTTLE POSITION SENSOR

1. Reconnect all harness connectors disconnected.
2. Perform [EC-698, "Throttle Valve Closed Position Learning"](#) .
3. Turn ignition switch ON.
4. Set selector lever to D position.
5. Check voltage between ECM terminals 50 (TP sensor 1signal), 69 (TP sensor 2signal) and ground under the following conditions.

Terminal	Accelerator pedal	Voltage
50 (Throttle position sensor 1)	Fully released	More than 0.36V
	Fully depressed	Less than 4.75V
69 (Throttle position sensor 2)	Fully released	Less than 4.75V
	Fully depressed	More than 0.36V

6. If NG, replace electric throttle control actuator and go to the next step.
7. Perform [EC-698, "Throttle Valve Closed Position Learning"](#) .
8. Perform [EC-698, "Idle Air Volume Learning"](#) .

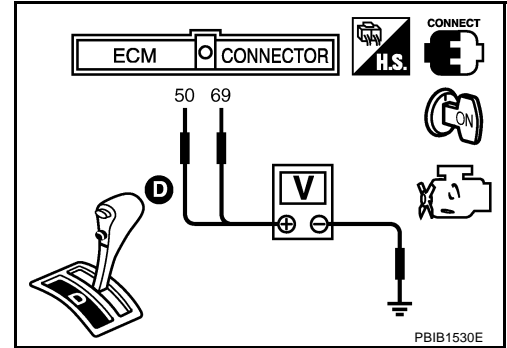

Removal and Installation
ELECTRIC THROTTLE CONTROL ACTUATOR

Refer to [EM-174, "INTAKE MANIFOLD"](#) .

DTC P0300 - P0308 MULTIPLE CYLINDER MISFIRE, NO. 1 - 8 CYLINDER MISFIRE

[VK45DE]

DTC P0300 - P0308 MULTIPLE CYLINDER MISFIRE, NO. 1 - 8 CYLINDER MISFIRE

PF0:00000

On Board Diagnosis Logic

ABS00C40

When a misfire occurs, engine speed will fluctuate. If the engine speed fluctuates enough to cause the crankshaft position (CKP) sensor (POS) signal to vary, ECM can determine that a misfire is occurring.

Sensor	Input signal to ECM	ECM function
Crankshaft position sensor (POS)	Engine speed	On board diagnosis of misfire

The misfire detection logic consists of the following two conditions.

- One Trip Detection Logic (Three Way Catalyst Damage)**
 On the first trip that a misfire condition occurs that can damage the three way catalyst (TWC) due to overheating, the MIL will blink.
 When a misfire condition occurs, the ECM monitors the CKP sensor signal every 200 engine revolutions for a change.
 When the misfire condition decreases to a level that will not damage the TWC, the MIL will turn off.
 If another misfire condition occurs that can damage the TWC on a second trip, the MIL will blink.
 When the misfire condition decreases to a level that will not damage the TWC, the MIL will remain on.
 If another misfire condition occurs that can damage the TWC, the MIL will begin to blink again.
- Two Trip Detection Logic (Exhaust quality deterioration)**
 For misfire conditions that will not damage the TWC (but will affect vehicle emissions), the MIL will only light when the misfire is detected on a second trip. During this condition, the ECM monitors the CKP sensor signal every 1,000 engine revolutions.
 A misfire malfunction can be detected on any one cylinder or on multiple cylinders.

DTC No.	Trouble diagnosis name	DTC detecting condition	Possible cause
P0300 0300	Multiple cylinder misfire detected	Multiple cylinder misfire.	<ul style="list-style-type: none"> ● Improper spark plug ● Insufficient compression ● Incorrect fuel pressure ● The injector circuit is open or shorted ● Fuel injector ● Intake air leak ● The ignition signal circuit is open or shorted ● Lack of fuel ● Signal plate ● Heated oxygen sensor 1 ● Incorrect PCV hose connection
P0301 0301	No.1 cylinder misfire detected	No. 1 cylinder misfires.	
P0302 0302	No. 2 cylinder misfire detected	No. 2 cylinder misfires.	
P0303 0303	No. 3 cylinder misfire detected	No. 3 cylinder misfires.	
P0304 0304	No. 4 cylinder misfire detected	No. 4 cylinder misfires.	
P0305 0305	No. 5 cylinder misfire detected	No. 5 cylinder misfires.	
P0306 0306	No. 6 cylinder misfire detected	No. 6 cylinder misfires.	
P0307 0307	No. 7 cylinder misfire detected	No. 7 cylinder misfires.	
P0308 0308	No. 8 cylinder misfire detected	No. 8 cylinder misfires.	

DTC Confirmation Procedure

ABS00C4P

CAUTION:

Always drive vehicle in safe manner according to traffic conditions and obey all traffic laws when driving.

NOTE:

If DTC Confirmation Procedure has been previously conducted, always turn ignition switch OFF and wait at least 10 seconds before conducting the next test.

WITH CONSULT-II

1. Turn ignition switch ON, and select "DATA MONITOR" mode with CONSULT-II.
2. Start engine and warm it up to normal operating temperature.
3. Turn ignition switch OFF and wait at least 10 seconds.
4. Restart engine and let it idle for about 15 minutes.
5. If 1st trip DTC is detected, go to [EC-950, "Diagnostic Procedure"](#)

DATA MONITOR	
MONITOR	NO DTC
ENG SPEED	XXX rpm
COOLAN TEMP/S	XXX °C
VHCL SPEED SE	XXX km/h
B/FUEL SCHDL	XXX msec
PBIB0164E	

NOTE:

If 1st trip DTC is not detected during above procedure, performing the following procedure is advised.

1. Turn ignition switch OFF and wait at least 10 seconds.
2. Start engine and drive the vehicle under the similar conditions to (1st trip) Freeze Frame Data for a certain time. Refer to the table below.
Hold the accelerator pedal as steady as possible.

The similar conditions to (1st trip) Freeze Frame Data means the vehicle operation that the following conditions should be satisfied at the same time.

Engine speed	Engine speed in the freeze frame data ± 400 rpm
Vehicle speed	Vehicle speed in the freeze frame data ± 10 km/h (6 MPH)
Engine coolant temperature (T) condition	When the freeze frame data shows lower than 70 °C (158 °F), T should be lower than 70 °C (158 °F).
	When the freeze frame data shows higher than or equal to 70 °C (158 °F), T should be higher than or equal to 70 °C (158 °F).

The time to driving varies according to the engine speed in the freeze frame data.

Engine speed	Time
Around 1,000 rpm	Approximately 10 minutes
Around 2,000 rpm	Approximately 5 minutes
More than 3,000 rpm	Approximately 3.5 minutes

WITH GST

Follow the procedure "WITH CONSULT-II" above.

Diagnostic Procedure

ABS00C4Q

1. CHECK FOR INTAKE AIR LEAK AND PCV HOSE

1. Start engine and run it at idle speed.
2. Listen for the sound of the intake air leak.
3. Check PCV hose connection.

OK or NG

- OK >> GO TO 2.
NG >> Discover air leak location and repair.

2. CHECK FOR EXHAUST SYSTEM CLOGGING

Stop engine and visually check exhaust tube, three way catalyst and muffler for dents.

OK or NG

- OK >> GO TO 3.
NG >> Repair or replace it.

3. PERFORM POWER BALANCE TEST

With CONSULT-II

1. Perform "POWER BALANCE" in "ACTIVE TEST" mode.
2. Is there any cylinder which does not produce a momentary engine speed drop?

ACTIVE TEST	
POWER BALANCE	
MONITOR	
ENG SPEED	XXX rpm
MAS A/F SE-B1	XXX V

PBIB0133E

Without CONSULT-II

When disconnecting each injector harness connector one at a time, is there any cylinder which does not produce a momentary engine speed drop?

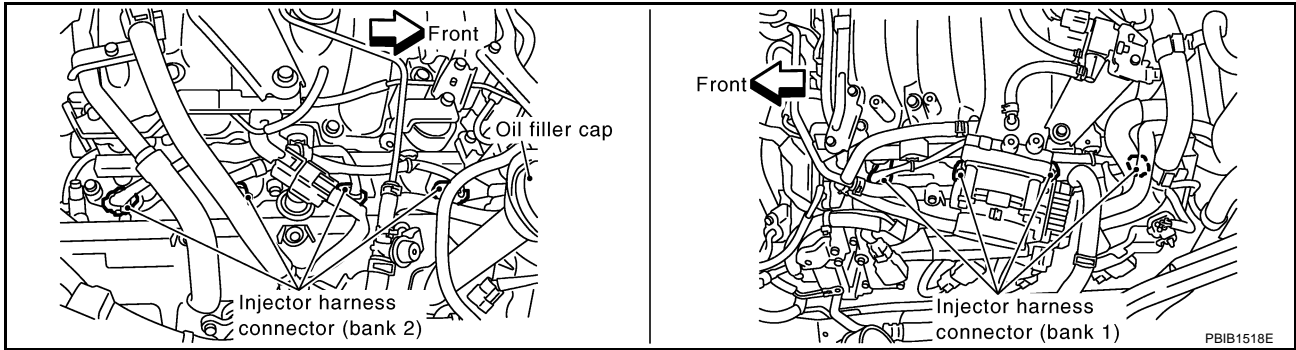

Yes or No

- Yes >> GO TO 4.
- No >> GO TO 7.

4. CHECK INJECTOR

Does each injector make an operating sound at idle?

Yes or No

- Yes >> GO TO 5.
- No >> Check injector(s) and circuit(s). Refer to [EC-1274](#), "[INJECTOR CIRCUIT](#)".

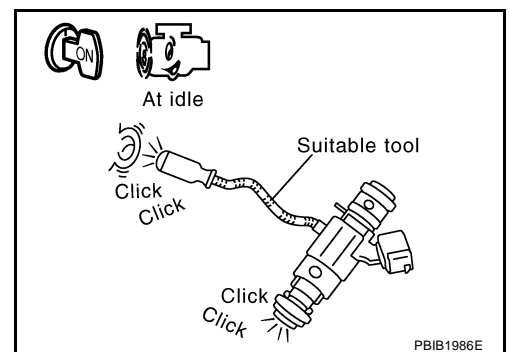

5. CHECK IGNITION SPARK

1. Turn ignition switch OFF.
2. Remove ignition coil assembly from rocker cover.
3. Connect a known-good spark plug to the ignition coil.
4. Disconnect all injector harness connectors.
5. Place end of spark plug against a suitable ground and crank engine.
6. Check for spark.

OK or NG

- OK >> GO TO 6.
NG >> Check ignition coil, power transistor and their circuits.
Refer to [EC-1262, "IGNITION SIGNAL"](#) .

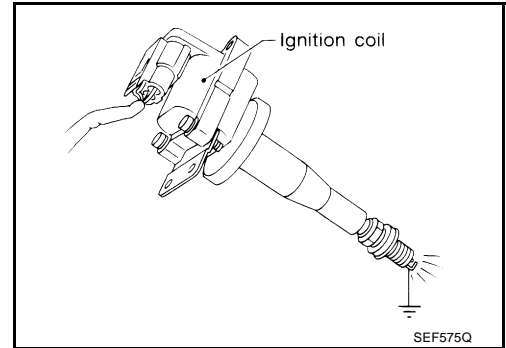

6. CHECK SPARK PLUGS

Remove the spark plugs and check for fouling, etc.

OK or NG

- OK >> GO TO 7.
NG >> Repair or replace spark plug(s) with standard type one(s). For spark plug type, refer to, [MA-26, "Changing Spark Plugs \(Platinum-Tipped Type\)"](#) .

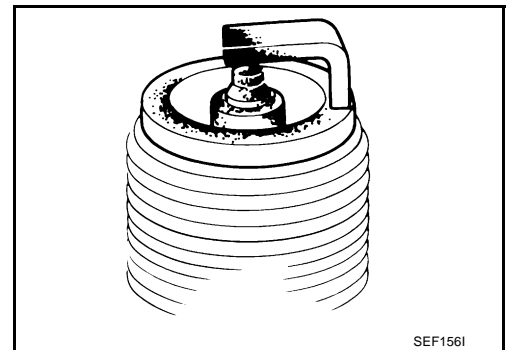

7. CHECK COMPRESSION PRESSURE

Check compression pressure. Refer to [EM-98, "CHECKING COMPRESSION PRESSURE"](#) .

Standard:	1,320 kPa (13.5 kg/cm² , 191 psi)/300 rpm
Minimum:	1,130 kPa (11.5 kg/cm² , 164 psi)/300 rpm
Difference between each cylinder:	98 kPa (1.0 kg/cm² , 14 psi)/300 rpm

OK or NG

- OK >> GO TO 8.
NG >> Check pistons, piston rings, valves, valve seats and cylinder head gaskets.

8. CHECK FUEL PRESSURE

1. Install all removed parts.
2. Release fuel pressure to zero. Refer to [EC-700, "FUEL PRESSURE RELEASE"](#) .
3. Install fuel pressure gauge and check fuel pressure. Refer to [EC-701, "FUEL PRESSURE CHECK"](#) .

At idle: Approx. 350 kPa (3.57 kg/cm² , 51 psi)

OK or NG

- OK >> GO TO 10.
NG >> GO TO 9.

9. DETECT MALFUNCTIONING PART

Check the following.

- Fuel pump and circuit (Refer to [EC-1280, "FUEL PUMP CIRCUIT"](#) .)
- Fuel pressure regulator (Refer to [EC-701, "FUEL PRESSURE CHECK"](#) .)
- Fuel lines
- Fuel filter for clogging

>> Repair or replace.

10. CHECK IGNITION TIMING

Check the following items. Refer to [EC-733, "Basic Inspection"](#) .

Items	Specifications
Target idle speed	650 ± 50 rpm (in P or N position)
Ignition timing	12 ± 5° BTDC (in P or N position)

OK or NG

- OK >> GO TO 11.
- NG >> Follow the [EC-733, "Basic Inspection"](#) .

11. CHECK HEATED OXYGEN SENSOR 1 (BANK 1)/(BANK 2)

Refer to [EC-870, "Component Inspection"](#) .

OK or NG

- OK >> GO TO 12.
- NG >> Replace (malfunctioning) heated oxygen sensor 1.

12. CHECK MASS AIR FLOW SENSOR

 **With CONSULT-II**

Check mass air flow sensor signal in "DATA MONITOR" mode with CONSULT-II.

- 2.0 - 6.0 g-m/sec: at idling**
- 7.0 - 20.0 g-m/sec: at 2,500 rpm**

 **With GST**

Check mass air flow sensor signal in MODE 1 with GST.

- 2.0 - 6.0 g-m/sec: at idling**
- 7.0 - 20.0 g-m/sec: at 2,500 rpm**

OK or NG

- OK >> GO TO 13.
- NG >> Check connectors for rusted terminals or loose connections in the mass air flow sensor circuit or ground. Refer to [EC-822, "DTC P0101 MAF SENSOR"](#) .

13. CHECK SYMPTOM MATRIX CHART

Check items on the rough idle symptom in [EC-738, "Symptom Matrix Chart"](#) .

OK or NG

- OK >> GO TO 14.
- NG >> Repair or replace.

14. ERASE THE 1ST TRIP DTC

Some tests may cause a 1st trip DTC to be set.

Erase the 1st trip DTC from the ECM memory after performing the tests. Refer to [EC-715, "HOW TO ERASE EMISSION-RELATED DIAGNOSTIC INFORMATION"](#) .

>> GO TO 15.

15. CHECK INTERMITTENT INCIDENT

Refer to [EC-784, "TROUBLE DIAGNOSIS FOR INTERMITTENT INCIDENT"](#) .

>> **INSPECTION END**

DTC P0327, P0328, P0332, P0333 KS

PF2:22060

Component Description

ABS00C4R

The knock sensor is attached to the cylinder block. It senses engine knocking using a piezoelectric element. A knocking vibration from the cylinder block is sensed as vibrational pressure. This pressure is converted into a voltage signal and sent to the ECM.

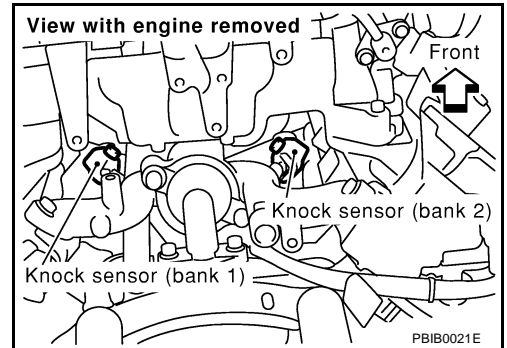

On Board Diagnosis Logic

ABS00C4S

The MIL will not light up for these diagnoses.

DTC No.	Trouble diagnosis name	DTC detecting condition	Possible cause
P0327 0327 (bank 1)	Knock sensor circuit low input	An excessively low voltage from the sensor is sent to ECM.	<ul style="list-style-type: none"> ● Harness or connectors (The sensor circuit is open or shorted.) ● Knock sensor
P0332 0332 (bank 2)			
P0328 0328 (bank 1)	Knock sensor circuit high input	An excessively high voltage from the sensor is sent to ECM.	
P0333 0333 (bank 2)			

DTC Confirmation Procedure

ABS00C4T

NOTE:

If DTC Confirmation Procedure has been previously conducted, always turn ignition switch OFF and wait at least 10 seconds before conducting the next test.

TESTING CONDITION:

Before performing the following procedure, confirm that battery voltage is more than 10V at idle.

WITH CONSULT-II

1. Turn ignition switch ON and select "DATA MONITOR" mode with CONSULT-II.
2. Start engine and run it for at least 5 seconds at idle speed.
3. If 1st trip DTC is detected, go to [EC-957, "Diagnostic Procedure"](#)

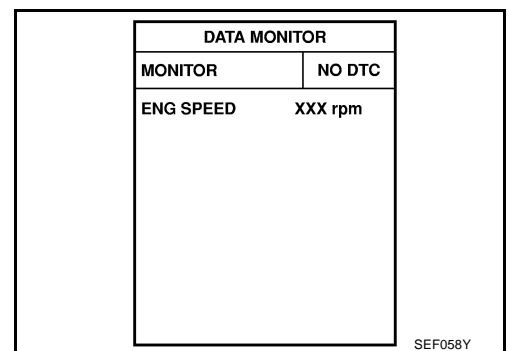

WITH GST

Follow the procedure "WITH CONSULT-II" above.

Wiring Diagram

ABS00C4U

EC-KS-01

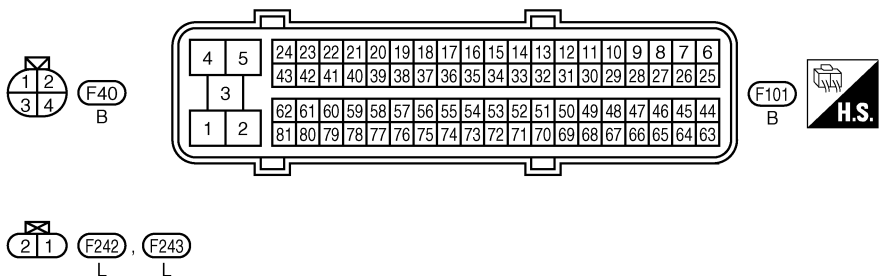
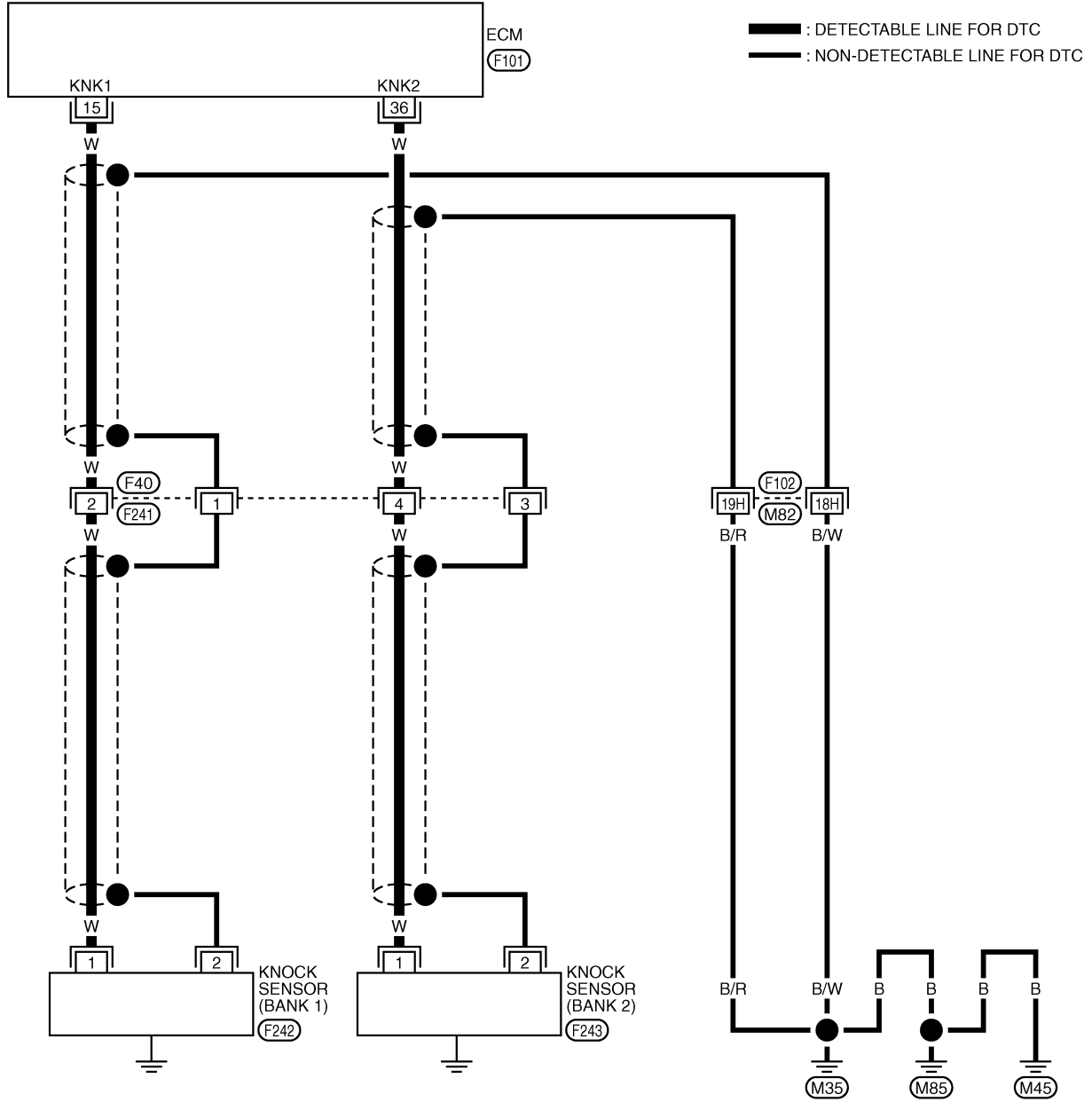

REFER TO THE FOLLOWING.
 (F102) -SUPER MULTIPLE JUNCTION (SMJ)

TBWM0241E

Specification data are reference values and are measured between each terminal and ground.

CAUTION:

Do not use ECM ground terminals when measuring input/output voltage. Doing so may result in damage to the ECM's transistor. Use a ground other than ECM terminals, such as the ground.

TER-MINAL NO.	WIRE COLOR	ITEM	CONDITION	DATA (DC Voltage)
15	W	Knock sensor (bank 1)	[Engine is running] ● Idle speed	Approximately 2.5V
36	W	Knock sensor (bank 2)		

Diagnostic Procedure

ABS00C4V

1. CHECK KNOCK SENSOR INPUT SIGNAL CIRCUIT FOR OPEN AND SHORT-I

1. Turn ignition switch OFF.
2. Disconnect ECM harness connector.
3. Check resistance between ECM terminals 15, 36 and ground. Refer to Wiring Diagram.

NOTE:

It is necessary to use an ohmmeter which can measure more than 10 MΩ.

Resistance: Approximately 532 - 588 kΩ [at 20°C (68°F)]

4. Also check harness for short to ground and short to power.

OK or NG

- OK >> GO TO 5.
- NG >> GO TO 2.

2. CHECK KNOCK SENSOR INPUT SIGNAL CIRCUIT FOR OPEN AND SHORT-II

1. Disconnect knock sensor harness connector.
2. Check harness continuity between ECM terminal 15 and knock sensor (bank1) terminal 1, ECM terminal 36 and knock sensor (bank 2) terminal 1. Refer to Wiring Diagram.

Continuity should exist.

3. Also check harness for short to ground and short to power.

OK or NG

- OK >> GO TO 4.
- NG >> GO TO 3.

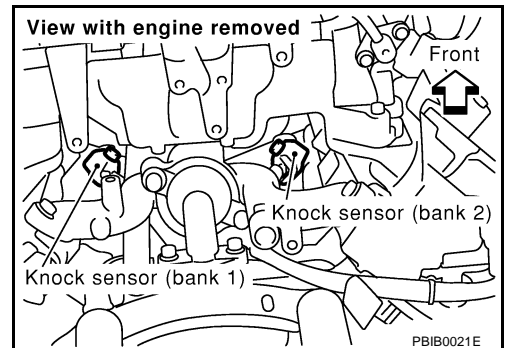

3. DETECT MALFUNCTIONING PART

Check the following.

- Harness connectors F40, F241
- Harness for open or short between ECM and knock sensor

>> Repair open circuit or short to ground or short to power in harness or connectors.

4. CHECK KNOCK SENSOR

Refer to [EC-959, "Component Inspection"](#) .

OK or NG

- OK >> GO TO 5.
- NG >> Replace knock sensor.

5. CHECK GROUND CONNECTIONS

1. Turn ignition switch OFF.
2. Loosen and retighten three ground screws on the body.
Refer to [EC-791, "Ground Inspection"](#).

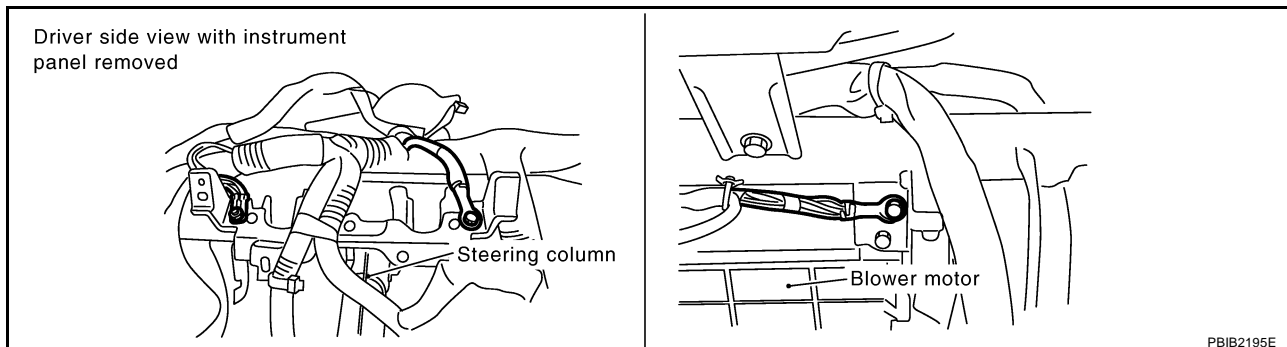

OK or NG

- OK >> GO TO 6.
NG >> Repair or replace ground connections.

6. CHECK KNOCK SENSOR SHIELD CIRCUIT FOR OPEN AND SHORT

1. Disconnect knock sensor harness connector.
2. Check harness continuity between knock sensor terminal 2 and ground. Refer to Wiring Diagram.

Continuity should exist.

OK or NG

- OK >> GO TO 8.
NG >> GO TO 7.

7. DETECT MALFUNCTIONING PART

Check the following.

- Harness connectors F40, F241
- Harness connectors F102, M82
- Harness for open or short between knock sensor terminal 2 and ground

>> Repair open circuit or short power in harness or connectors.

8. CHECK INTERMITTENT INCIDENT

Refer to [EC-784, "TROUBLE DIAGNOSIS FOR INTERMITTENT INCIDENT"](#).

>> **INSPECTION END**

Component Inspection

KNOCK SENSOR

Check resistance between knock sensor terminal 1 and ground.

NOTE:

It is necessary to use an ohmmeter which can measure more than 10 M Ω .

Resistance: Approximately 532 - 588 k Ω [at 20°C (68°F)]

CAUTION:

Do not use any knock sensors that have been dropped or physically damaged. Use only new ones.

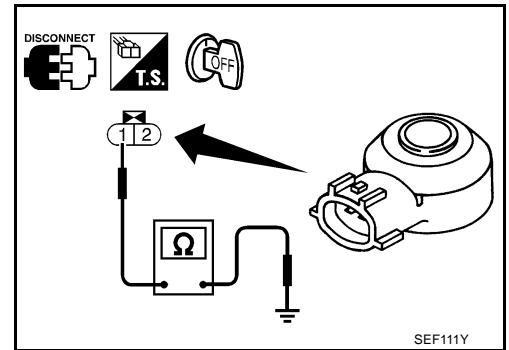

Removal and Installation

KNOCK SENSOR

Refer to [EM-240, "CYLINDER BLOCK"](#) .

A

EC

C

D

E

F

G

H

I

J

K

L

M

DTC P0335 CKP SENSOR (POS)

PFP:23731

Component Description

ABS00C4Y

The crankshaft position sensor (POS) is located on the A/T assembly facing the gear teeth (cogs) of the signal plate. It detects the fluctuation of the engine revolution.

The sensor consists of a permanent magnet and Hall IC.

When the engine is running, the high and low parts of the teeth cause the gap with the sensor to change.

The changing gap causes the magnetic field near the sensor to change.

Due to the changing magnetic field, the voltage from the sensor changes.

The ECM receives the voltage signal and detects the fluctuation of the engine revolution.

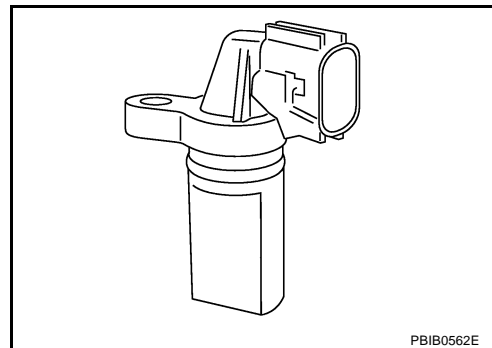

CONSULT-II Reference Value in Data Monitor Mode

ABS00C4Z

Specification data are reference values.

MONITOR ITEM	CONDITION	SPECIFICATION
ENG SPEED	<ul style="list-style-type: none"> ● Run engine and compare CONSULT-II value with the tachometer indication 	Almost the same speed as the tachometer indication

On Board Diagnosis Logic

ABS00C50

DTC No.	Trouble diagnosis name	DTC detecting condition	Possible cause
P0335 0335	Crankshaft position sensor (POS) circuit	<ul style="list-style-type: none"> ● The crankshaft position sensor (POS) signal is not detected by the ECM during the first few seconds of engine cranking. ● The proper pulse signal from the crankshaft position sensor (POS) is not sent to ECM while the engine is running. ● The crankshaft position sensor (POS) signal is not in the normal pattern during engine running. 	<ul style="list-style-type: none"> ● Harness or connectors (The sensor circuit is open or shorted) ● Crankshaft position sensor (POS) ● Signal plate

DTC Confirmation Procedure

ABS00C51

NOTE:

If DTC Confirmation Procedure has been previously conducted, always turn ignition switch OFF and wait at least 10 seconds before conducting the next test.

TESTING CONDITION:

Before performing the following procedure, confirm that battery voltage is more than 10.5V with ignition switch ON.

WITH CONSULT-II

1. Turn ignition switch ON and select "DATA MONITOR" mode with CONSULT-II.
2. Crank engine for at least 2 seconds and run it for at least 5 seconds at idle speed.
3. If 1st trip DTC is detected, go to [EC-962, "Diagnostic Procedure"](#)

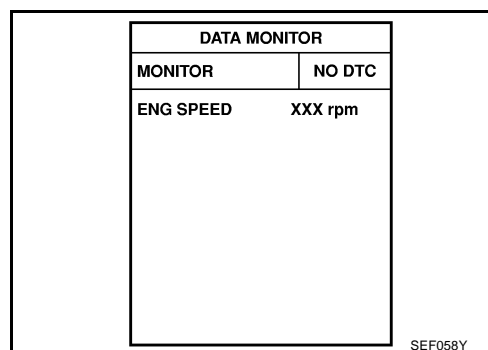

WITH GST

Follow the procedure "WITH CONSULT-II" above.

DTC P0335 CKP SENSOR (POS)

[VK45DE]

ABS00DOY

Wiring Diagram

EC-POS-01

A
EC
C
D
E
F
G
H
I
J
K
L
M

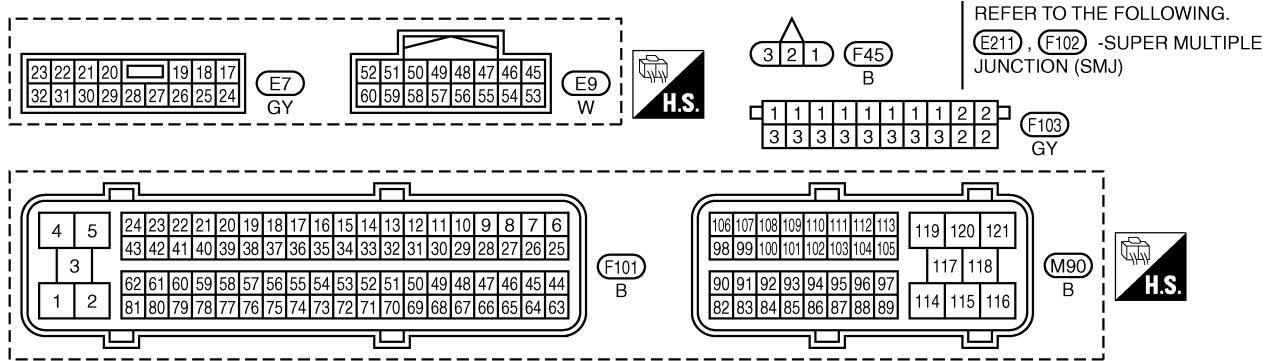
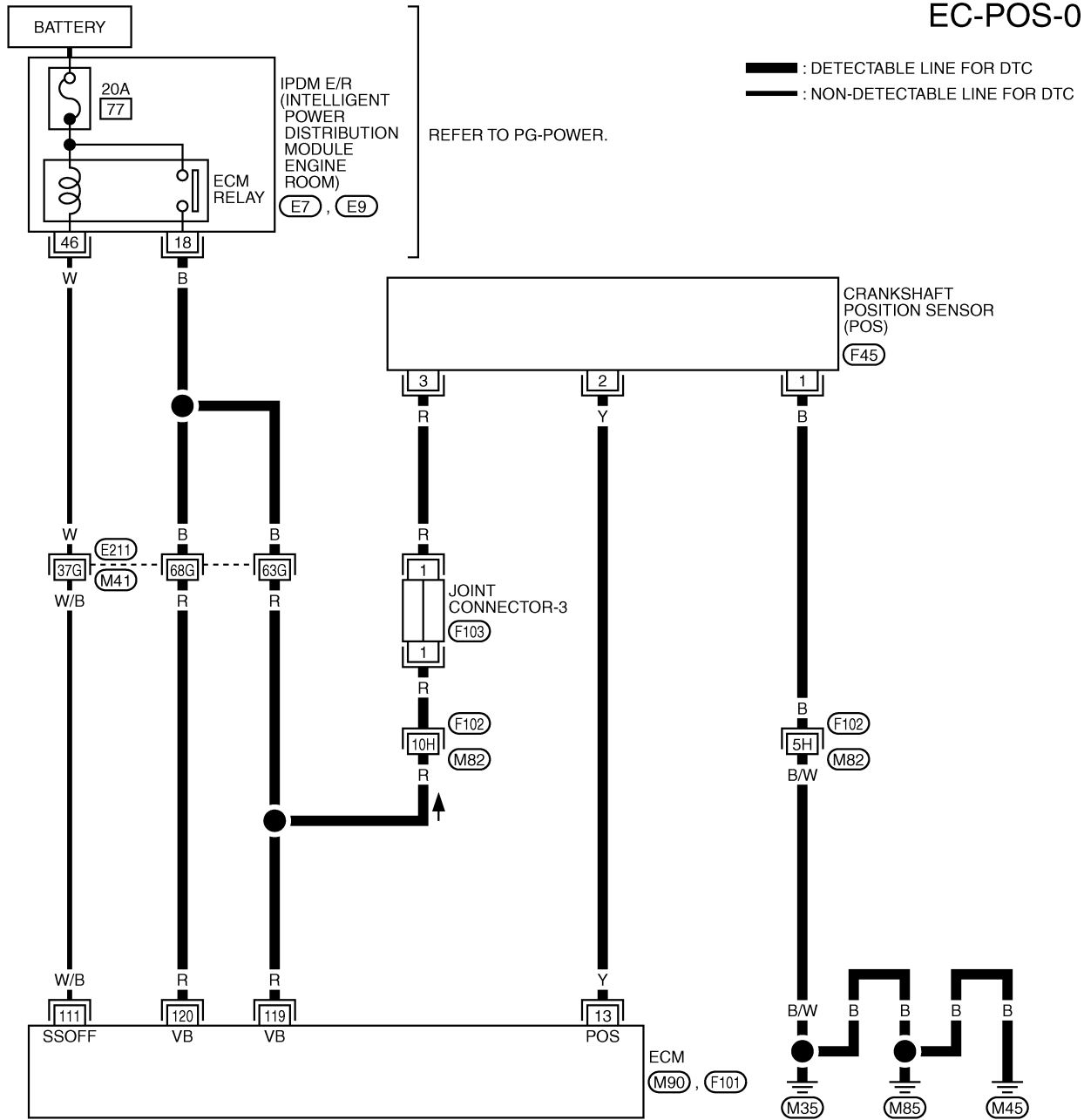

DTC P0335 CKP SENSOR (POS)

[VK45DE]

Specification data are reference values and are measured between each terminal and ground.
Pulse signal is measured by CONSULT-II.

CAUTION:

Do not use ECM ground terminals when measuring input/output voltage. Doing so may result in damage to the ECM's transistor. Use a ground other than ECM terminals, such as the ground.

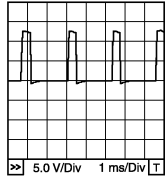
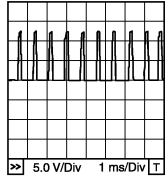
TER-MINAL NO.	WIRE COLOR	ITEM	CONDITION	DATA (DC Voltage)
13	Y	Crankshaft position sensor (POS)	<p>[Engine is running]</p> <ul style="list-style-type: none"> ● Warm-up condition ● Idle speed <p>NOTE: The pulse cycle changes depending on rpm at idle</p>	<p>1.0 - 2.0V★</p>  <p>PBB1041E</p>
			<p>[Engine is running]</p> <ul style="list-style-type: none"> ● Engine speed is 2,000 rpm 	<p>1.0 - 2.0V★</p>  <p>PBB1042E</p>

★: Average voltage for pulse signal (Actual pulse signal can be confirmed by oscilloscope.)

Diagnostic Procedure

ABS00C53

1. CHECK GROUND CONNECTIONS

1. Turn ignition switch OFF.
2. Loosen and retighten three ground screws on the body.
Refer to [EC-791, "Ground Inspection"](#).

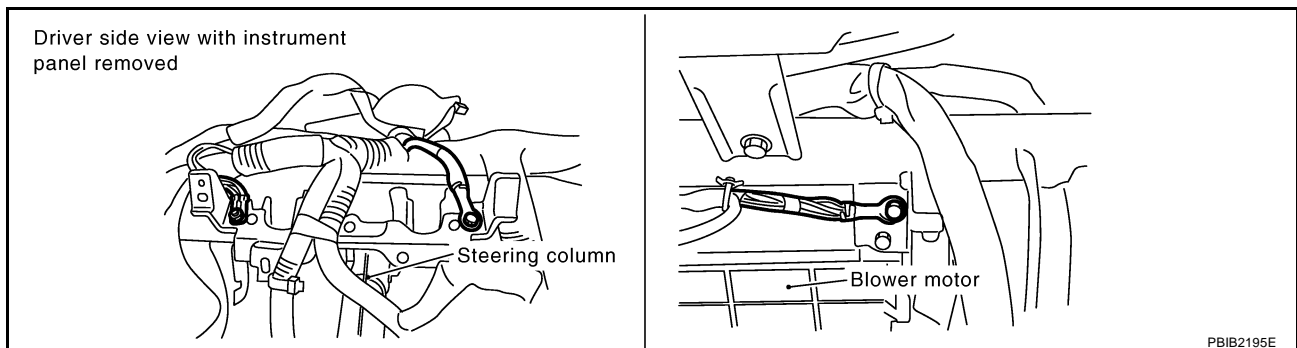

OK or NG

- OK >> GO TO 2.
NG >> Repair or replace ground connections.

2. CHECK CRANKSHAFT POSITION (CKP) SENSOR (POS) POWER SUPPLY CIRCUIT

1. Disconnect crankshaft position (CKP) sensor (POS) harness connector.
2. Turn ignition switch ON.

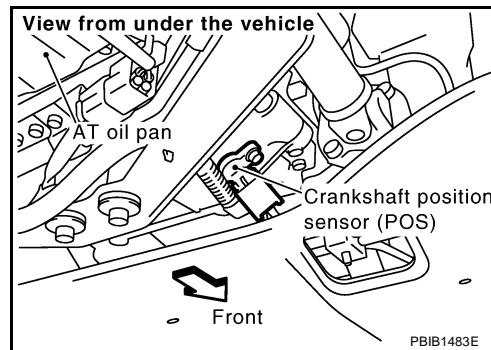

3. Check voltage between CKP sensor (POS) terminal 3 and ground with CONSULT-II or tester.

Voltage: Battery voltage

4. Also check harness for short to ground and short to power.

OK or NG

- OK >> GO TO 4.
NG >> GO TO 3.

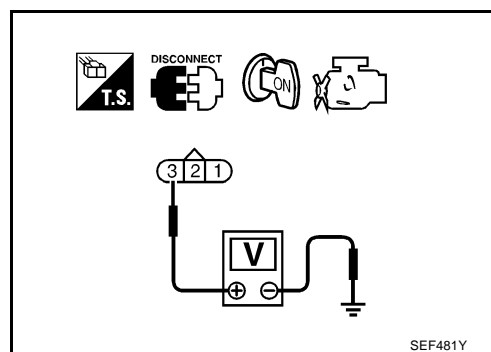

3. DETECT MALFUNCTIONING PART

Check the following.

- Harness connectors E211, M41
- Harness connectors F102, M82
- Joint connector-3
- Harness for open or short between crankshaft position sensor (POS) and ECM
- Harness for open or short between crankshaft position sensor (POS) and IPDM E/R

>> Repair open circuit or short to ground or short to power in harness or connectors.

4. CHECK CKP SENSOR (POS) GROUND CIRCUIT FOR OPEN AND SHORT

1. Turn ignition switch OFF.
2. Check harness continuity between CKP sensor (POS) terminal 1 and ground. Refer to Wiring Diagram.

Continuity should exist.

3. Also check harness for short to power.

OK or NG

- OK >> GO TO 6.
NG >> GO TO 5.

5. DETECT MALFUNCTIONING PART

Check the following.

- Harness connectors F102, M82
- Harness for open or short between crankshaft position sensor (POS) and ground

>> Repair open circuit or short to power in harness or connectors.

6. CHECK CKP SENSOR (POS) INPUT SIGNAL CIRCUIT FOR OPEN AND SHORT

1. Disconnect ECM harness connector.
2. Check harness continuity between ECM terminal 13 and CKP sensor (POS) terminal 2.
Refer to Wiring Diagram.

Continuity should exist.

3. Also check harness for short to ground and short to power.

OK or NG

OK >> GO TO 7.

NG >> Repair open circuit or short to ground or short to power in harness or connectors.

7. CHECK CRANKSHAFT POSITION SENSOR (POS)

Refer to [EC-964, "Component Inspection"](#) .

OK or NG

OK >> GO TO 8.

NG >> Replace crankshaft position sensor (POS).

8. CHECK GEAR TOOTH

Visually check for chipping signal plate gear tooth.

OK or NG

OK >> GO TO 9.

NG >> Replace the signal plate.

9. CHECK INTERMITTENT INCIDENT

Refer to [EC-784, "TROUBLE DIAGNOSIS FOR INTERMITTENT INCIDENT"](#) .

>> **INSPECTION END**

Component Inspection CRANKSHAFT POSITION SENSOR (POS)

ABS00C54

1. Loosen the fixing bolt of the sensor.
2. Disconnect crankshaft position sensor (POS) harness connector.
3. Remove the sensor.
4. Visually check the sensor for chipping.

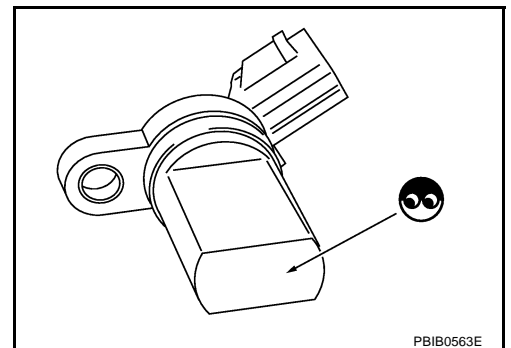

DTC P0335 CKP SENSOR (POS)

[VK45DE]

5. Check resistance as shown in the figure.

Terminal No. (Polarity)	Resistance Ω [at 25°C (77°F)]
1 (+) - 2 (-)	Except 0 or ∞
1 (+) - 3 (-)	
2 (+) - 3 (-)	

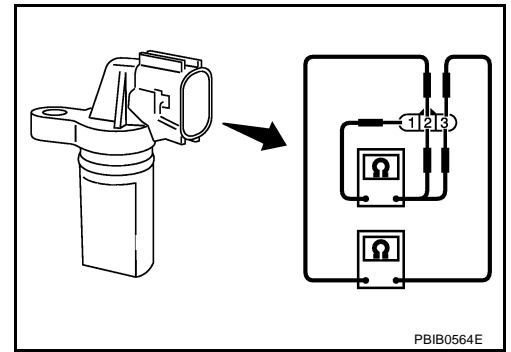

Removal and Installation CRANKSHAFT POSITION SENSOR (POS)

Refer to [AT-270, "REMOVAL"](#) .

A
EC
C
D
E
F
G
H
I
J
K
L
M

DTC P0340 CAMSHAFT POSITION (CMP) SENSOR (PHASE)

PFP:23731

Component Description

ABS00C56

The camshaft position sensor (PHASE) senses the protrusion of exhaust valve cam sprocket to identify a particular cylinder. The camshaft position sensor (PHASE) senses the piston position. When the crankshaft position sensor (POS) system becomes inoperative, the camshaft position sensor (PHASE) provides various controls of engine parts instead, utilizing timing of cylinder identification signals.

The sensor consists of a permanent magnet and Hall IC.

When engine is running, the high and low parts of the teeth cause the gap with the sensor to change.

The changing gap causes the magnetic field near the sensor to change.

Due to the changing magnetic field, the voltage from the sensor changes.

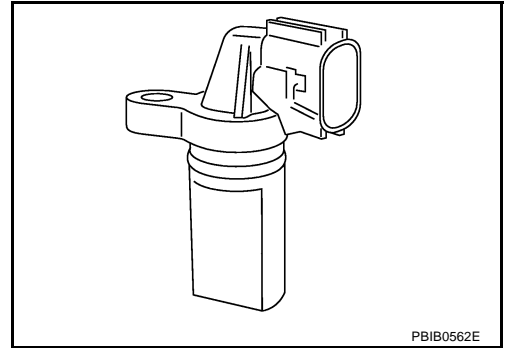

On Board Diagnosis Logic

ABS00C57

DTC No.	Trouble diagnosis name	DTC detecting condition	Possible cause
P0340 0340	Camshaft position sensor (PHASE) circuit	<ul style="list-style-type: none"> ● The cylinder No. signal is not sent to ECM for the first few seconds during engine cranking. ● The cylinder No. signal is not sent to ECM during engine running. ● The cylinder No. signal is not in the normal pattern during engine running. 	<ul style="list-style-type: none"> ● Harness or connectors (The sensor circuit is open or shorted) ● Camshaft position sensor (PHASE) ● Camshaft (Exhaust) ● Starter motor (Refer to SC-10 .) ● Starting system circuit (Refer to SC-10 .) ● Dead (Weak) battery

DTC Confirmation Procedure

ABS00C58

NOTE:

If DTC Confirmation Procedure has been previously conducted, always turn ignition switch OFF and wait at least 10 seconds before conducting the next test.

TESTING CONDITION:

Before performing the following procedure, confirm that battery voltage is more than 10.5V with ignition switch ON.

WITH CONSULT-II

1. Turn ignition switch ON.
2. Select "DATA MONITOR" mode with CONSULT-II.
3. Crank engine for at least 2 seconds and run it for at least 5 seconds at idle speed.
4. If 1st trip DTC is detected, go to [EC-968, "Diagnostic Procedure"](#).
If 1st trip DTC is not detected, go to next step.
5. Maintaining engine speed at more than 800 rpm for at least 5 seconds.
6. If 1st trip DTC is detected, go to [EC-968, "Diagnostic Procedure"](#).

DATA MONITOR	
MONITOR	NO DTC
ENG SPEED	XXX rpm

SEF058Y

WITH GST

Follow the procedure "WITH CONSULT-II" above.

DTC P0340 CAMSHAFT POSITION (CMP) SENSOR (PHASE)

[VK45DE]

ABS00C59

Wiring Diagram

A
EC
C
D
E
F
G
H
I
J
K
L
M

EC-PHASE-01

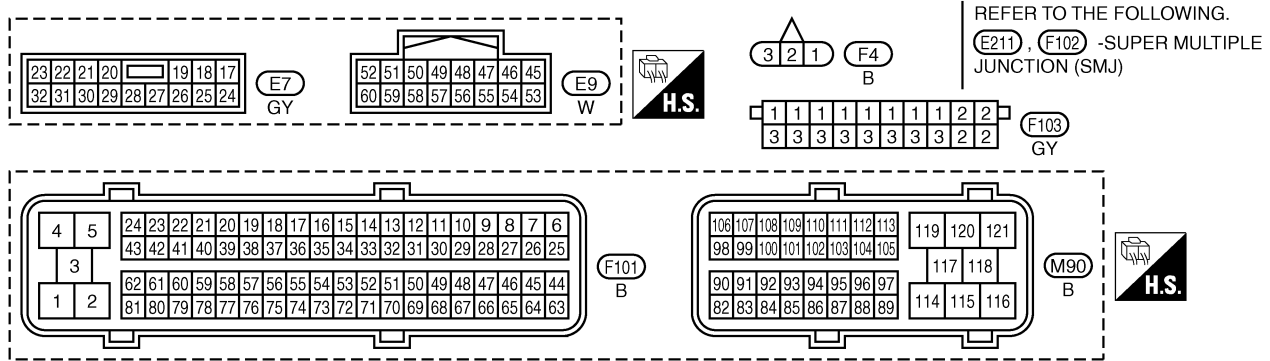
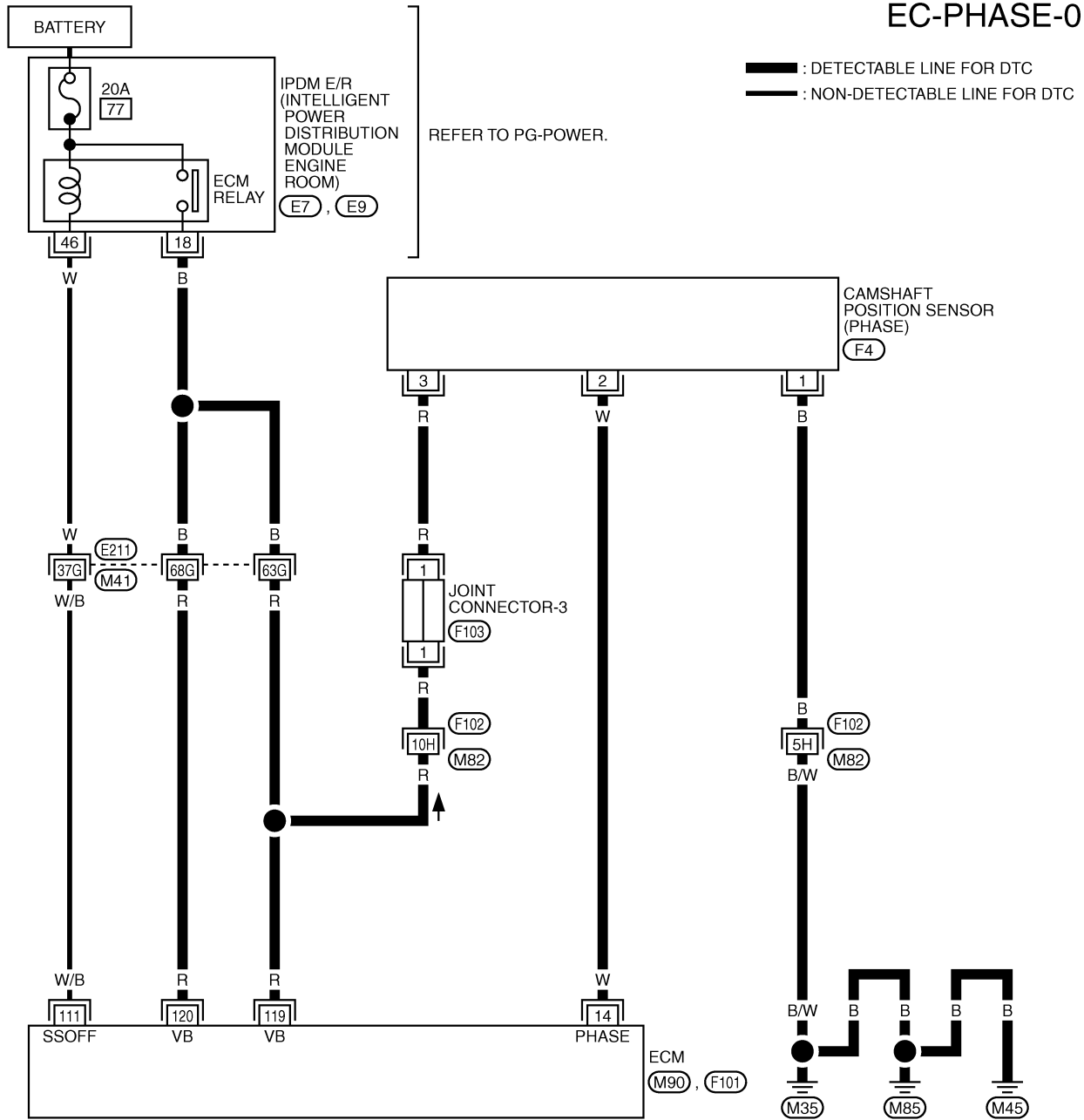

TBWM0243E

DTC P0340 CAMSHAFT POSITION (CMP) SENSOR (PHASE)

[VK45DE]

Specification data are reference values and are measured between each terminal and ground.
Pulse signal is measured by CONSULT-II.

CAUTION:

Do not use ECM ground terminals when measuring input/output voltage. Doing so may result in damage to the ECM's transistor. Use a ground other than ECM terminals, such as the ground.

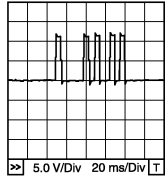
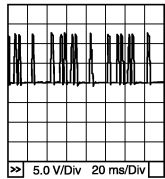
TER-MINAL NO.	WIRE COLOR	ITEM	CONDITION	DATA (DC Voltage)
14	W	Camshaft position sensor (PHASE)	<p>[Engine is running]</p> <ul style="list-style-type: none"> ● Warm-up condition ● Idle speed <p>NOTE: The pulse cycle changes depending on rpm at idle</p>	<p>1.0 - 4.0V★</p>  <p>5.0 V/Div 20 ms/Div</p> <p>PBIB1039E</p>
			<p>[Engine is running]</p> <ul style="list-style-type: none"> ● Engine speed is 2,000 rpm 	<p>1.0 - 4.0V★</p>  <p>5.0 V/Div 20 ms/Div</p> <p>PBIB1040E</p>

★: Average voltage for pulse signal (Actual pulse signal can be confirmed by oscilloscope.)

Diagnostic Procedure

ABS00C5A

1. CHECK STARTING SYSTEM

Turn ignition switch to START position.

Does the engine turn over?

Does the starter motor operate?

Yes or No

Yes >> GO TO 2.

No >> Check starting system. (Refer to [SC-10, "STARTING SYSTEM"](#) .)

2. CHECK GROUND CONNECTIONS

1. Turn ignition switch OFF.
2. Loosen and retighten three ground screws on the body.
Refer to [EC-791, "Ground Inspection"](#) .

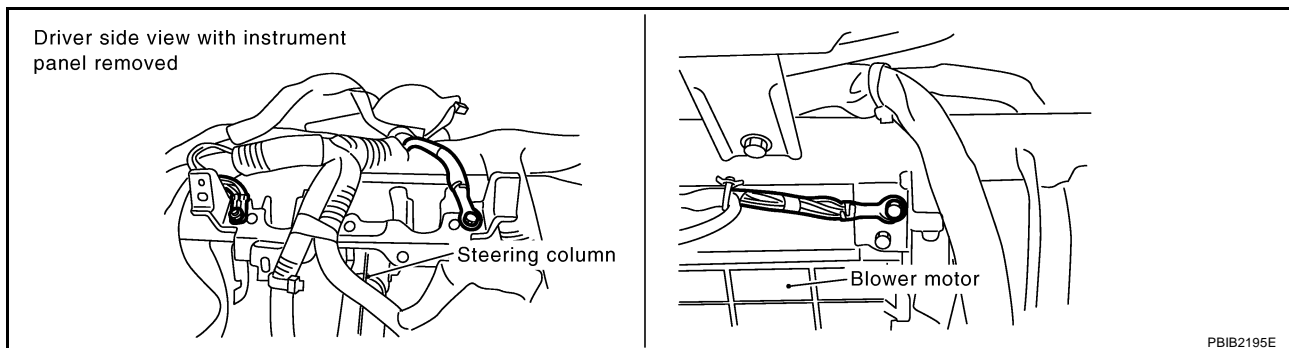

OK or NG

OK >> GO TO 3.

NG >> Repair or replace ground connections.

3. CHECK CAMSHAFT POSITION (CMP) SENSOR (PHASE) POWER SUPPLY CIRCUIT

1. Disconnect camshaft position (CMP) sensor (PHASE) harness connector.
2. Turn ignition switch ON.

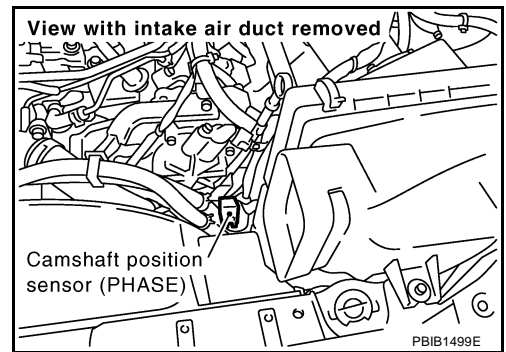

3. Check voltage between CMP sensor (PHASE) terminal 3 and ground with CONSULT-II or tester.

Voltage: Battery voltage

4. Also check harness for short to ground and short to power.

OK or NG

- OK >> GO TO 5.
NG >> GO TO 4.

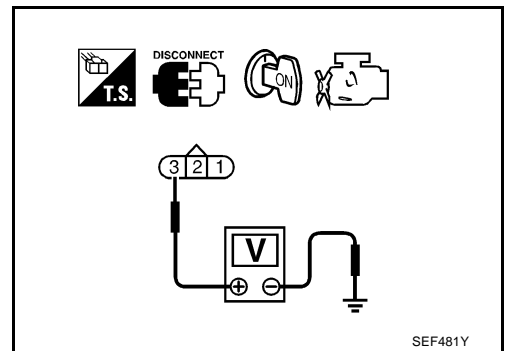

4. DETECT MALFUNCTIONING PART

Check the following.

- Harness connectors E211, M41
- Harness connectors F102, M82
- Joint connector-3
- Harness for open or short between camshaft position sensor (PHASE) and ECM
- Harness for open or short between camshaft position sensor (PHASE) and IPDM E/R

>> Repair open circuit or short to ground or short to power in harness or connectors.

5. CHECK CMP SENSOR (PHASE) GROUND CIRCUIT FOR OPEN AND SHORT

1. Turn ignition switch OFF.
2. Check harness continuity between CMP sensor (PHASE) terminal 1 and ground.

Continuity should exist.

3. Also check harness for short to power.

OK or NG

- OK >> GO TO 7.
NG >> GO TO 6.

6. DETECT MALFUNCTIONING PART

Check the following.

- Harness connectors F102, M82
- Harness for open or short between CMP sensor (PHASE) and ground

>> Repair open circuit or short to power in harness or connectors.

7. CHECK CMP SENSOR (PHASE) INPUT SIGNAL CIRCUIT FOR OPEN AND SHORT

1. Disconnect ECM harness connector.
2. Check harness continuity between ECM terminal 14 and CMP sensor (PHASE) terminal 2.
Refer to Wiring Diagram.

Continuity should exist.

3. Also check harness for short to ground or short to power.

OK or NG

OK >> GO TO 8.

NG >> Repair open circuit or short to ground or short to power in harness or connectors.

8. CHECK CAMSHAFT POSITION SENSOR (PHASE)

Refer to [EC-970, "Component Inspection"](#) .

OK or NG

OK >> GO TO 9.

NG >> Replace camshaft position sensor (PHASE).

9. CHECK INTERMITTENT INCIDENT

Refer to [EC-784, "TROUBLE DIAGNOSIS FOR INTERMITTENT INCIDENT"](#) .

>> INSPECTION END

Component Inspection CAMSHAFT POSITION SENSOR (PHASE)

ABS00C5B

1. Loosen the fixing bolt of the sensor.
2. Disconnect camshaft position sensor (PHASE) harness connector.
3. Remove the sensor.
4. Visually check the sensor for chipping.

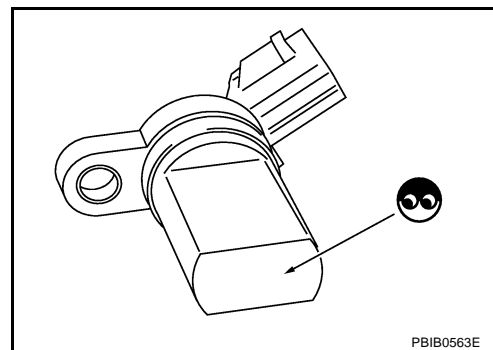

PBIB0563E

5. Check resistance as shown in the figure.

Terminal No. (Polarity)	Resistance Ω [at 25°C (77°F)]
3(+) - 1 (-)	Except 0 or ∞
2 (+) - 1 (-)	
3 (+) - 2 (-)	

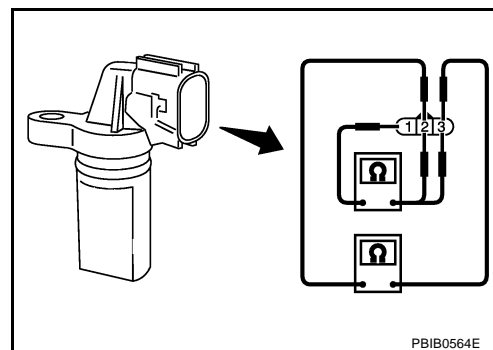

PBIB0564E

Removal and Installation CAMSHAFT POSITION SENSOR (PHASE)

ABS00C5C

Refer to [EM-208, "CAMSHAFT"](#) .

DTC P0420, P0430 THREE WAY CATALYST FUNCTION

PFP:20905

On Board Diagnosis Logic

ABS00C5D

The ECM monitors the switching frequency ratio of heated oxygen sensors 1 and 2.

A three way catalyst (manifold) with high oxygen storage capacity will indicate a low switching frequency of heated oxygen sensor 2. As oxygen storage capacity decreases, the heated oxygen sensor 2 switching frequency will increase.

When the frequency ratio of heated oxygen sensors 1 and 2 approaches a specified limit value, the three way catalyst (manifold) malfunction is diagnosed.

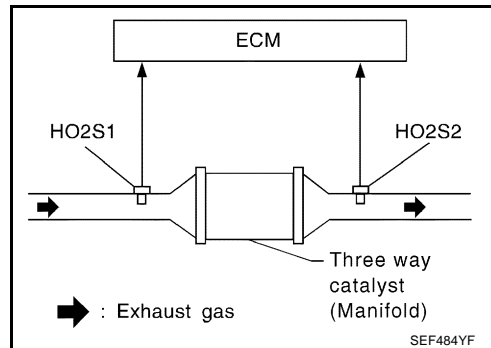

DTC No.	Trouble diagnosis name	DTC detecting condition	Possible cause
P0420 0420 (Bank 1)	Catalyst system efficiency below threshold	<ul style="list-style-type: none"> ● Three way catalyst (manifold) does not operate properly. ● Three way catalyst (manifold) does not have enough oxygen storage capacity. 	<ul style="list-style-type: none"> ● Three way catalyst (manifold) ● Exhaust tube ● Intake air leaks ● Fuel injector ● Fuel injector leaks ● Spark plug ● Improper ignition timing
P0430 0430 (Bank 2)			

DTC Confirmation Procedure

ABS00C5E

NOTE:

If DTC Confirmation Procedure has been previously conducted, always turn ignition switch OFF and wait at least 10 seconds before conducting the next test.

Ⓟ WITH CONSULT-II

TESTING CONDITION:

Do not hold engine speed for more than the specified minutes below.

1. Turn ignition switch ON and select "DATA MONITOR" mode with CONSULT-II.
2. Start engine and warm it up to the normal operating temperature.
3. Turn ignition switch OFF and wait at least 10 seconds.
4. Start engine and keep the engine speed between 3,500 and 4,000 rpm for at least 1 minute under no load.
5. Let engine idle for 1 minute.
6. Make sure that "COOLAN TEMP/S" indicates more than 70°C (158°F).
If not, warm up engine and go to next step when "COOLAN TEMP/S" indication reaches to 70°C (158°F).
7. Open engine hood.

DATA MONITOR	
MONITOR	NO DTC
ENG SPEED	XXX rpm
COOLAN TEMP/S	XXX °C
VHCL SPEED SE	XXX km/h
B/FUEL SCHDL	XXX msec

SEF189Y

DTC P0420, P0430 THREE WAY CATALYST FUNCTION

[VK45DE]

8. Select "DTC & SRT CONFIRMATION" then "SRT WORK SUPPORT" mode with CONSULT-II.
9. Rev engine up to 2,000 to 3,000 rpm and hold it for 3 consecutive minutes then release the accelerator pedal completely. If "INCMP" of "CATALYST" changed to "CMPLT", go to step 12.
10. Wait 5 seconds at idle.

SRT WORK SUPPORT	
CATALYST	INCMP
EVAP SYSTEM	INCMP
HO2S HTR	CMPLT
HO2S	INCMP
MONITOR	
ENG SPEED	XXX rpm
MAS A/F SE-B1	XXX V
B/FUEL SCHDL	XXX msec
A/F ALPHA-B1	XXX V
COOLAN TEMP/S	XX °C
HO2S1 (B1)	XXX V

SEF940Z

11. Rev engine up to 2,000 to 3,000 rpm and maintain it until "INCMP" of "CATALYST" changes to "CMPLT" (It will take approximately 5 minutes). If not "CMPLT", stop engine and cool it down to less than 70°C (158°F) and then retest from step 1.

SRT WORK SUPPORT	
CATALYST	CMPLT
EVAP SYSTEM	INCMP
HO2S HTR	CMPLT
HO2S	INCMP
MONITOR	
ENG SPEED	XXX rpm
MAS A/F SE-B1	XXX V
B/FUEL SCHDL	XXX msec
A/F ALPHA-B1	XXX V
COOLAN TEMP/S	XX °C
HO2S1 (B1)	XXX V

SEF941Z

12. Select "SELF-DIAG RESULTS" mode with CONSULT-II.
13. Confirm that the 1st trip DTC is not detected. If the 1st trip DTC is detected, go to [EC-973, "Diagnostic Procedure"](#).

SELF DIAG RESULTS	
DTC RESULTS	TIME
NO DTC IS DETECTED. FURTHER TESTING MAY BE REQUIRED.	

SEF535Z

Overall Function Check

ABS00C5F

Use this procedure to check the overall function of the three way catalyst (manifold). During this check, a 1st trip DTC might not be confirmed.

WITH GST

1. Turn ignition switch OFF and wait at least 10 seconds.
2. Start engine and keep the engine speed between 3,500 and 4,000 rpm for at least 1 minute under no load.
3. Let engine idle for 1 minute.
4. Open engine hood.
5. Set voltmeters probes between ECM terminals 16 [HO2S1 (bank 1) signal], 35 [HO2S1 (bank 2) signal] and ground, and ECM terminals 55 [HO2S2 (bank 1) signal], 74 [HO2S2 (bank 2) signal] and ground.
6. Keep engine speed at 2,000 rpm constant under no load.

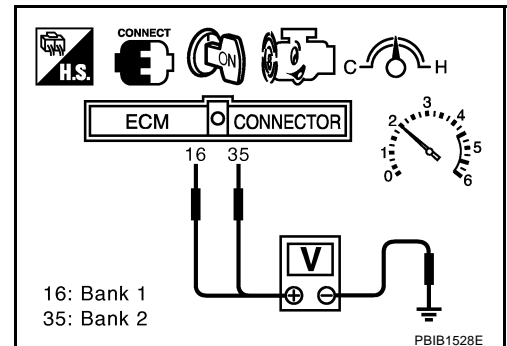

DTC P0420, P0430 THREE WAY CATALYST FUNCTION

[VK45DE]

7. Make sure that the voltage switching frequency (high & low) between ECM terminals 55 and ground, or 74 and ground is very less than that of ECM terminals 16 and ground, or 35 and ground.

Switching frequency ratio = A/B

A: Heated oxygen sensor 2 voltage switching frequency

B: Heated oxygen sensor 1 voltage switching frequency

This ratio should be less than 0.75.

If the ratio is greater than above, it means three way catalyst (manifold) does not operate properly. Go to [EC-973, "Diagnostic Procedure"](#).

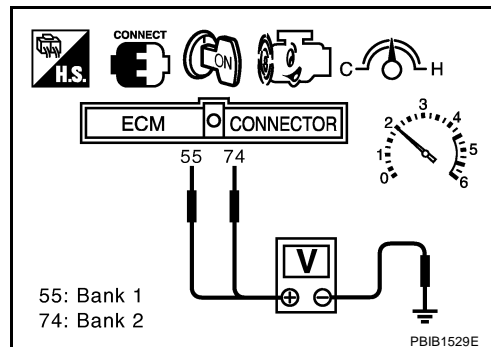

NOTE:

If the voltage at terminal 16 or 35 does not switch periodically more than 5 times within 10 seconds at step 7, perform trouble diagnosis for DTC P0133, P0153 first. (See [EC-872](#).)

Diagnostic Procedure

ABS00C5G

1. CHECK EXHAUST SYSTEM

Visually check exhaust tubes and muffler for dent.

OK or NG

OK >> GO TO 2.

NG >> Repair or replace.

2. CHECK EXHAUST GAS LEAK

1. Start engine and run it at idle.
2. Listen for an exhaust gas leak before the three way catalyst (manifold).

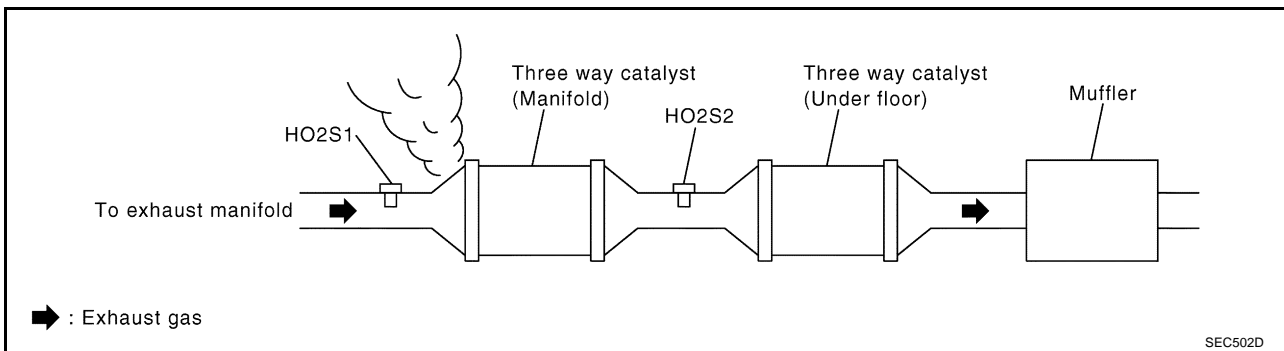

OK or NG

OK >> GO TO 3.

NG >> Repair or replace.

3. CHECK INTAKE AIR LEAK

Listen for an intake air leak after the mass air flow sensor.

OK or NG

OK >> GO TO 4.

NG >> Repair or replace.

4. CHECK IGNITION TIMING

Check the following items. Refer to [EC-733, "Basic Inspection"](#) .

Items	Specifications
Target idle speed	650 ± 50 rpm (in P or N position)
Ignition timing	12 ± 5° BTDC (in P or N position)

OK or NG

- OK >> GO TO 5.
- NG >> Follow the [EC-733, "Basic Inspection"](#) .

5. CHECK INJECTORS

1. Stop engine and then turn ignition switch ON.
2. Check voltage between ECM terminals 21, 22, 23, 40, 41, 42, 44, 63 and ground with CONSULT-II or tester.
Refer to Wiring Diagram for Injectors, [EC-1275](#) .

Battery voltage should exist.

OK or NG

- OK >> GO TO 6.
- NG >> Perform [EC-1276, "Diagnostic Procedure"](#) .

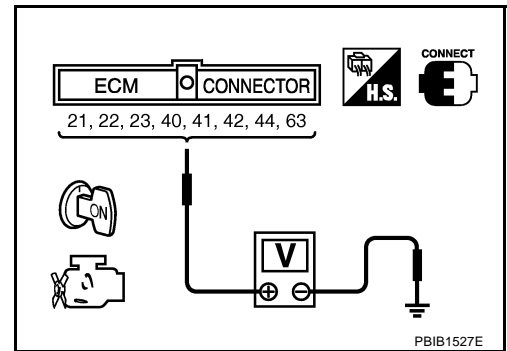

6. CHECK IGNITION SPARK

1. Turn ignition switch OFF.
2. Remove ignition coil assembly from rocker cover.
3. Connect a known-good spark plug to the ignition coil assembly.
4. Disconnect all injector harness connectors.
5. Place end of spark plug against a suitable ground and crank engine.
6. Check for spark.

OK or NG

- OK >> GO TO 7.
- NG >> Check ignition coil with power transistor and their circuit.
Refer to [EC-1262, "IGNITION SIGNAL"](#) .

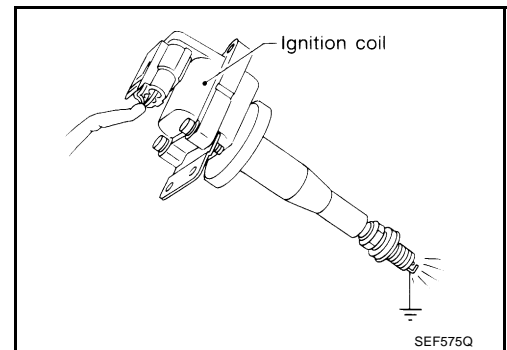

7. CHECK INJECTOR

1. Turn ignition switch OFF.
2. Remove injector assembly.
Refer to [EM-188, "FUEL INJECTOR AND FUEL TUBE"](#) .
Keep fuel hose and all injectors connected to injector gallery.
3. Disconnect all ignition coil harness connectors.
4. Reconnect injector harness connectors.
5. Turn ignition switch ON.
Make sure fuel does not drip from injector.

OK or NG

OK (Does not drip.)>>GO TO 8.

NG (Drips.)>>Replace the injector(s) from which fuel is dripping.

8. CHECK INTERMITTENT INCIDENT

Refer to [EC-784, "TROUBLE DIAGNOSIS FOR INTERMITTENT INCIDENT"](#) .Trouble is fixed.>>**INSPECTION END**

Trouble is not fixed.>>Replace three way catalyst assembly.

A

EC

C

D

E

F

G

H

I

J

K

L

M

DTC P0441 EVAP CONTROL SYSTEM

PFP:14950

System Description

ABS00C5H

NOTE:

If DTC P0441 is displayed with other DTC such as P2122, P2123, P2127, P2128 or P2138, first perform trouble diagnosis for other DTC.

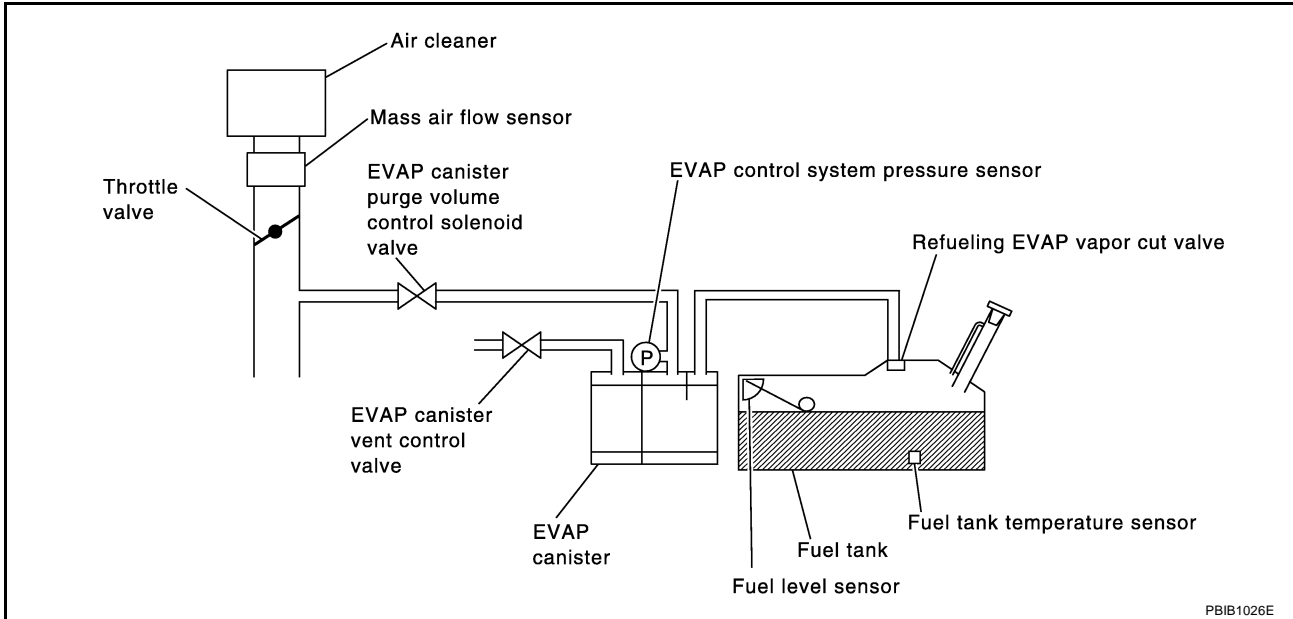

In this evaporative emission (EVAP) control system, purge flow occurs during non-closed throttle conditions. Purge volume is related to air intake volume. Under normal purge conditions (non-closed throttle), the EVAP canister purge volume control solenoid valve is open to admit purge flow. Purge flow exposes the EVAP control system pressure sensor to intake manifold vacuum.

On Board Diagnosis Logic

ABS00C5I

Under normal conditions (non-closed throttle), sensor output voltage indicates if pressure drop and purge flow are adequate. If not, a malfunction is determined.

DTC No.	Trouble diagnosis name	DTC detecting condition	Possible cause
P0441 0441	EVAP control system incorrect purge flow	EVAP control system does not operate properly, EVAP control system has a leak between intake manifold and EVAP control system pressure sensor.	<ul style="list-style-type: none"> ● EVAP canister purge volume control solenoid valve stuck closed ● EVAP control system pressure sensor and the circuit ● Loose, disconnected or improper connection of rubber tube ● Blocked rubber tube ● Cracked EVAP canister ● EVAP canister purge volume control solenoid valve circuit ● Accelerator pedal position sensor ● Blocked purge port ● EVAP canister vent control valve

DTC Confirmation Procedure

ABS00C5J

CAUTION:

Always drive vehicle at a safe speed.

NOTE:

If DTC Confirmation Procedure has been previously conducted, always turn ignition switch OFF and wait at least 10 seconds before conducting the next test.

TESTING CONDITION:

Always perform test at a temperature of 5°C (41°F) or more.

Ⓟ WITH CONSULT-II

1. Start engine and warm it up to normal operating temperature.
2. Turn ignition switch OFF and wait at least 10 seconds.
3. Start engine and let it idle for at least 70 seconds.
4. Select "PURG FLOW P0441" of "EVAPORATIVE SYSTEM" in "DTC CONFIRMATION" mode with CONSULT-II.
5. Touch "START".
If "COMPLETED" is displayed, go to step 7.
6. When the following conditions are met, "TESTING" will be displayed on the CONSULT-II screen. Maintain the conditions continuously until "TESTING" changes to "COMPLETED". (It will take at least 35 seconds.)

Selector lever	Suitable position
VHCL SPEED SE	32 - 120 km/h (20 - 75 MPH)
ENG SPEED	500 - 3,000 rpm
B/FUEL SCHDL	1.0 - 10.0 msec
COOLAN TEMP/S	70 - 100°C (158 - 212°F)

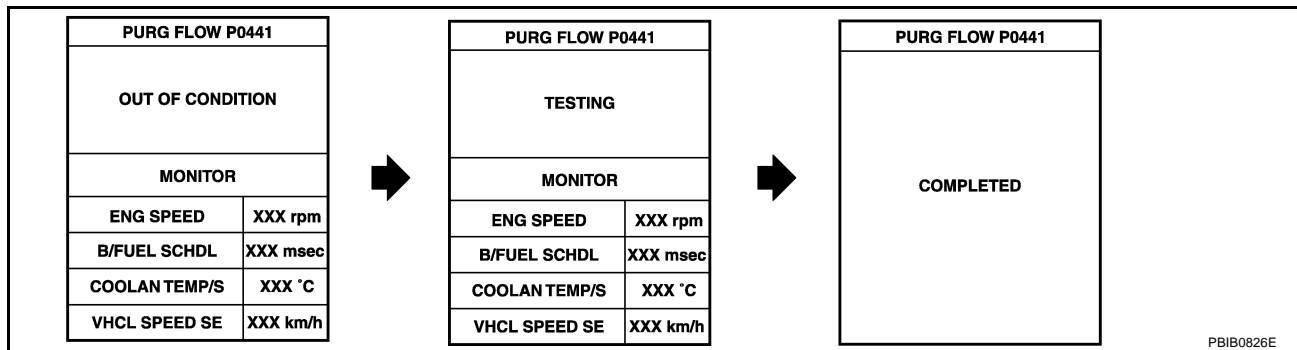

If "TESTING" is not changed for a long time, retry from step 2.

7. Make sure that "OK" is displayed after touching "SELF-DIAG RESULTS". If "NG" is displayed, refer to [EC-978, "Diagnostic Procedure"](#).

Overall Function Check

ABS00C5K

Use this procedure to check the overall monitoring function of the EVAP control system purge flow monitoring. During this check, a 1st trip DTC might not be confirmed.

Ⓟ WITH GST

1. Lift up drive wheels.
2. Start engine (VDC switch OFF) and warm it up to normal operating temperature.
3. Turn ignition switch OFF, wait at least 10 seconds.
4. Start engine and wait at least 70 seconds.
5. Set voltmeter probes to ECM terminals 32 (EVAP control system pressure sensor signal) and ground.
6. Check EVAP control system pressure sensor value at idle speed and note it.
7. Establish and maintain the following conditions for at least 1 minute.

Air conditioner switch	ON
Headlamp switch	ON
Rear window defogger switch	ON
Engine speed	Approx. 3,000 rpm
Gear position	Any position other than P, N or R

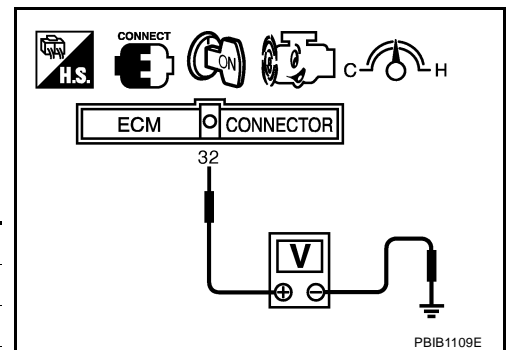

8. Verify that EVAP control system pressure sensor value stays 0.1V less than the value at idle speed (measured at step 6) for at least 1 second.

9. If NG, go to [EC-978, "Diagnostic Procedure"](#) .

Diagnostic Procedure

ABS00C5L

1. CHECK EVAP CANISTER

1. Turn ignition switch OFF.
2. Check EVAP canister for cracks.

OK or NG

OK (With CONSULT-II)>>GO TO 2.
 OK (Without CONSULT-II)>>GO TO 3.
 NG >> Replace EVAP canister.

2. CHECK PURGE FLOW

 **With CONSULT-II**

1. Disconnect vacuum hose connected to EVAP canister purge volume control solenoid valve at EVAP service port and install vacuum gauge. For the location of EVAP service port, refer to [EC-1321, "EVAPORATIVE EMISSION LINE DRAWING"](#) .
2. Start engine and let it idle.
3. Select "PURG VOL CONT/V" in "ACTIVE TEST" mode with CONSULT-II.
4. Rev engine up to 2,000 rpm.
5. Touch "Qd" and "Qu" on CONSULT-II screen to adjust "PURG VOL CONT/V" opening and check vacuum existence.

PURG VOL CONT/V	Vacuum
100%	Should exist.
0%	Should not exist.

OK or NG

OK >> GO TO 7.
 NG >> GO TO 4.

ACTIVE TEST	
PURG VOL CONT/V	XXX %
MONITOR	
ENG SPEED	XXX rpm
A/F ALPHA-B1	XX %
A/F ALPHA-B2	XX %

PBIB1678E

3. CHECK PURGE FLOW

 **Without CONSULT-II**

1. Start engine and warm it up to normal operating temperature.
2. Stop engine.
3. Disconnect vacuum hose connected to EVAP canister purge volume control solenoid valve at EVAP service port and install vacuum gauge. For the location of EVAP service port, refer to [EC-1321, "EVAPORATIVE EMISSION LINE DRAWING"](#) .
4. Start engine and let it idle for at least 80 seconds.
5. Check vacuum gauge indication when revving engine up to 2,000 rpm.

Vacuum should exist.

6. Release the accelerator pedal fully and let idle.

Vacuum should not exist.

OK or NG

OK >> GO TO 7.
 NG >> GO TO 4.

4. CHECK EVAP PURGE LINE

1. Turn ignition switch OFF.
2. Check EVAP purge line for improper connection or disconnection.
Refer to [EC-1321, "EVAPORATIVE EMISSION LINE DRAWING"](#) .

OK or NG

- OK >> GO TO 5.
- NG >> Repair it.

5. CHECK EVAP PURGE HOSE AND PURGE PORT

1. Disconnect purge hoses connected to EVAP service port **A** and EVAP canister purge volume control solenoid valve **B** .
2. Blow air into each hose and EVAP purge port **C** .

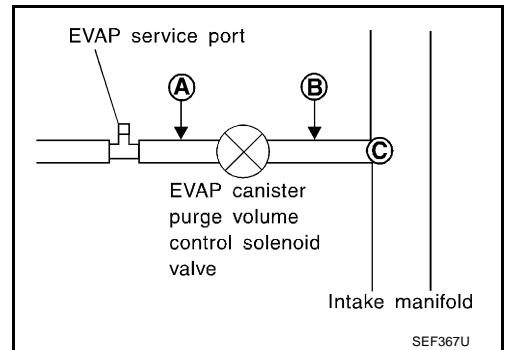

3. Check that air flows freely.

OK or NG

- OK (With CONSULT-II)>>GO TO 6.
- OK (Without CONSULT-II)>>GO TO 7.
- NG >> Repair or clean hoses and/or purge port.

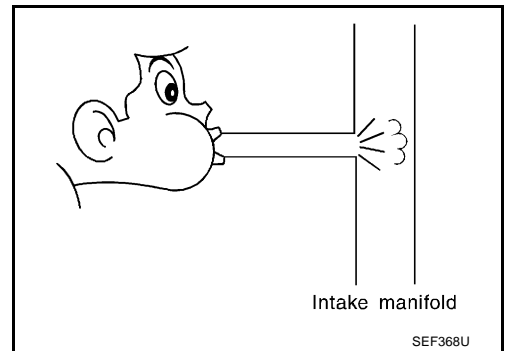

6. CHECK EVAP CANISTER PURGE VOLUME CONTROL SOLENOID VALVE

With CONSULT-II

1. Start engine.
2. Perform "PURG VOL CONT/V" in "ACTIVE TEST" mode with CONSULT-II. Check that engine speed varies according to the valve opening.

OK or NG

- OK >> GO TO 8.
- NG >> GO TO 7.

ACTIVE TEST	
PURG VOL CONT/V	XXX %
MONITOR	
ENG SPEED	XXX rpm
A/F ALPHA-B1	XX %
A/F ALPHA-B2	XX %

PBIB1678E

7. CHECK EVAP CANISTER PURGE VOLUME CONTROL SOLENOID VALVE

Refer to [EC-995, "Component Inspection"](#) .

OK or NG

- OK >> GO TO 8.
- NG >> Replace EVAP canister purge volume control solenoid valve.

8. CHECK EVAP CONTROL SYSTEM PRESSURE SENSOR CONNECTOR

1. Disconnect EVAP control system pressure sensor harness connector.
2. Check connectors for water.

Water should not exist.

OK or NG

- OK >> GO TO 9.
- NG >> Replace EVAP control system pressure sensor.

9. CHECK EVAP CONTROL SYSTEM PRESSURE SENSOR FUNCTION

Refer to DTC P0452 [EC-1008, "DTC Confirmation Procedure"](#) , P0453 [EC-1015, "DTC Confirmation Procedure"](#) .

OK or NG

- OK >> GO TO 10.
- NG >> Replace EVAP control system pressure sensor.

10. CHECK RUBBER TUBE FOR CLOGGING

1. Disconnect rubber tube connected to EVAP canister vent control valve.
2. Check the rubber tube for clogging.

OK or NG

- OK >> GO TO 11.
- NG >> Clean the rubber tube using an air blower.

11. CHECK EVAP CANISTER VENT CONTROL VALVE

Refer to [EC-1002, "Component Inspection"](#) .

OK or NG

- OK >> GO TO 12.
- NG >> Replace EVAP canister vent control valve.

12. CHECK EVAP PURGE LINE

Inspect EVAP purge line (pipe and rubber tube). Check for evidence of leaks.
Refer to [EC-1321, "EVAPORATIVE EMISSION LINE DRAWING"](#) .

OK or NG

- OK >> GO TO 13.
- NG >> Replace it.

13. CLEAN EVAP PURGE LINE

Clean EVAP purge line (pipe and rubber tube) using air blower.

>> GO TO 14.

14. CHECK INTERMITTENT INCIDENT

Refer to [EC-784, "TROUBLE DIAGNOSIS FOR INTERMITTENT INCIDENT"](#) .

>> **INSPECTION END**

DTC P0442 EVAP CONTROL SYSTEM

PFP:14950

On Board Diagnosis Logic

ABS00C5M

This diagnosis detects leaks in the EVAP purge line using engine intake manifold vacuum. If pressure does not increase, the ECM will check for leaks in the line between the fuel tank and EVAP canister purge volume control solenoid valve, under the following "Vacuum test" conditions. The EVAP canister vent control valve is closed to shut the EVAP purge line off. The EVAP canister purge volume control solenoid valve will then be opened to depressurize the EVAP purge line using intake manifold vacuum. After this occurs, the EVAP canister purge volume control solenoid valve will be closed.

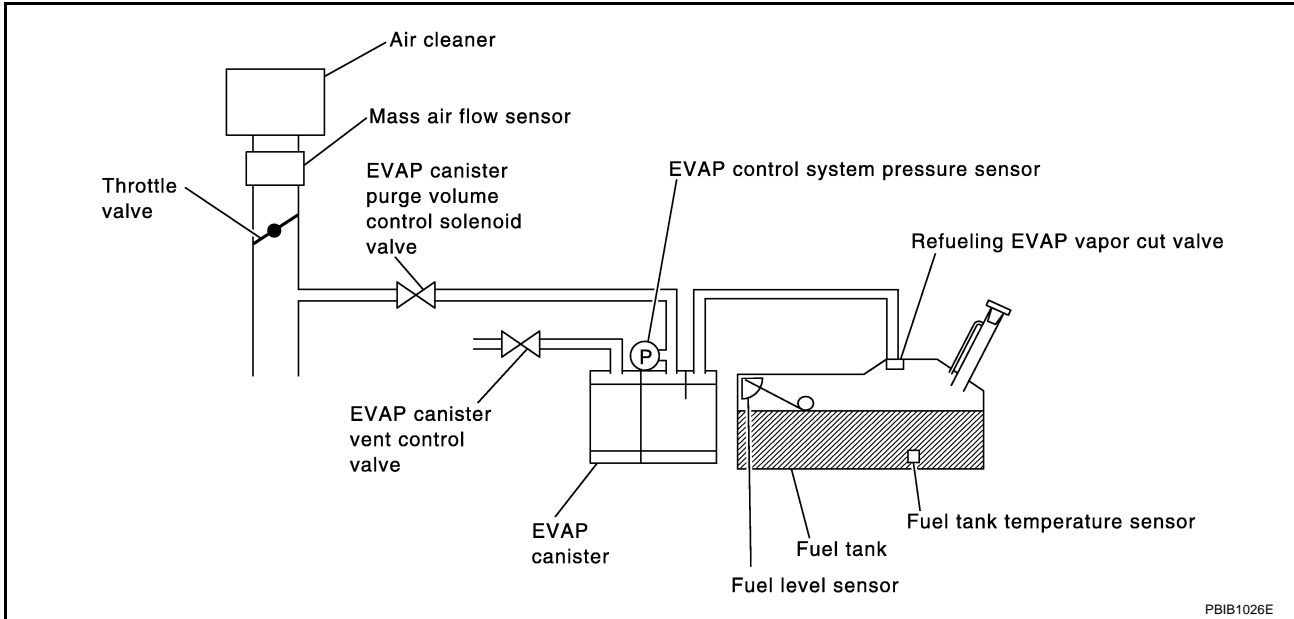

DTC No.	Trouble diagnosis name	DTC detecting condition	Possible cause
P0442 0442	EVAP control system small leak detected (negative pressure)	EVAP control system has a leak, EVAP control system does not operate properly.	<ul style="list-style-type: none"> ● Incorrect fuel tank vacuum relief valve ● Incorrect fuel filler cap used ● Fuel filler cap remains open or fails to close. ● Foreign matter caught in fuel filler cap. ● Leak is in line between intake manifold and EVAP canister purge volume control solenoid valve. ● Foreign matter caught in EVAP canister vent control valve. ● EVAP canister or fuel tank leaks ● EVAP purge line (pipe and rubber tube) leaks ● EVAP purge line rubber tube bent ● Loose or disconnected rubber tube ● EVAP canister vent control valve and the circuit ● EVAP canister purge volume control solenoid valve and the circuit ● Fuel tank temperature sensor ● O-ring of EVAP canister vent control valve is missing or damaged ● EVAP canister is saturated with water ● EVAP control system pressure sensor ● Fuel level sensor and the circuit ● Refueling EVAP vapor cut valve ● ORVR system leaks

CAUTION:

- Use only a genuine NISSAN fuel filler cap as a replacement. If an incorrect fuel filler cap is used, the MIL may come on.
- If the fuel filler cap is not tightened properly, the MIL may come on.
- Use only a genuine NISSAN rubber tube as a replacement.

DTC Confirmation Procedure

ABS00C5N

NOTE:

- If DTC Confirmation Procedure has been previously conducted, always turn ignition switch OFF and wait at least 10 seconds before conducting the next test.

TESTING CONDITION:

- Perform “DTC WORK SUPPORT” when the fuel level is between 1/4 and 3/4 full, and vehicle is placed on flat level surface.
- Always perform test at a temperature of 0 to 30°C (32 to 86°F).

WITH CONSULT-II

1. Turn ignition switch ON.
2. Turn ignition switch OFF and wait at least 10 seconds.
3. Turn ignition switch ON and select “DATA MONITOR” mode with CONSULT-II.
4. Make sure that the following conditions are met.
COOLAN TEMP/S: 0 - 70°C (32 - 158°F)
INT/A TEMP SE: 0 - 30°C (32 - 86°F)
5. Select “EVAP SML LEAK P0442/P1442” of “EVAPORATIVE SYSTEM” in “DTC WORK SUPPORT” mode with CONSULT-II.
 Follow the instruction displayed.

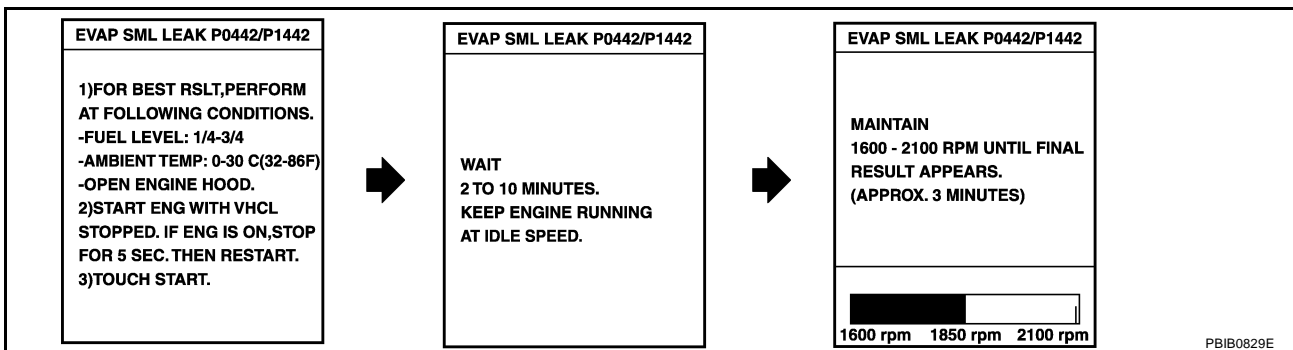

NOTE:

If the engine speed cannot be maintained within the range displayed on the CONSULT-II screen, go to [EC-733, "Basic Inspection"](#).

6. Make sure that “OK” is displayed.
 If “NG” is displayed, refer to [EC-983, "Diagnostic Procedure"](#).

NOTE:

Make sure that EVAP hoses are connected to EVAP canister purge volume control solenoid valve properly.

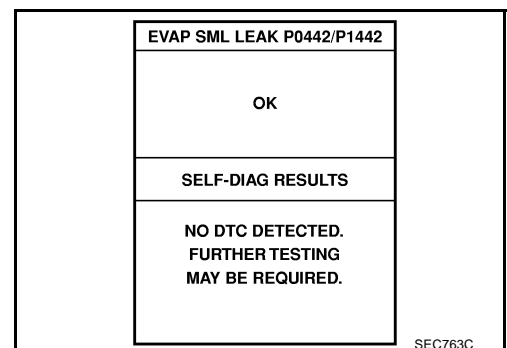

WITH GST

NOTE:

Be sure to read the explanation of [EC-713, "Driving Pattern"](#) before driving vehicle.

1. Start engine.
2. Drive vehicle according to [EC-713, "Driving Pattern"](#).

3. Stop vehicle.
4. Turn ignition switch OFF, wait at least 10 seconds and then turn ON.
5. Select MODE 7 with GST.
 - If P0442 is displayed on the screen, go to [EC-983, "Diagnostic Procedure"](#) .
 - If P0441 is displayed on the screen, go to [EC-978, "Diagnostic Procedure"](#) .

Diagnostic Procedure

ABS00C50

1. CHECK FUEL FILLER CAP DESIGN

1. Turn ignition switch OFF.
2. Check for genuine NISSAN fuel filler cap design.

OK or NG

- OK >> GO TO 2.
- NG >> Replace with genuine NISSAN fuel filler cap.

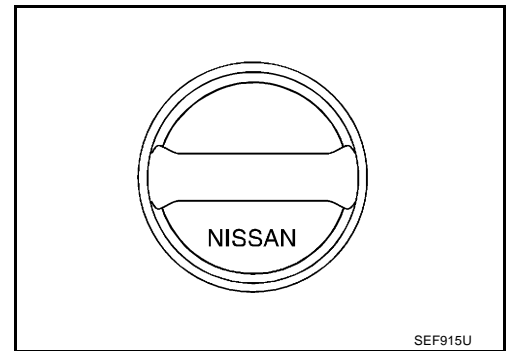

2. CHECK FUEL FILLER CAP INSTALLATION

Check that the cap is tightened properly by rotating the cap clockwise.

OK or NG

- OK >> GO TO 3.
- NG >> 1. Open fuel filler cap, then clean cap and fuel filler neck threads using air blower.
2. Retighten until ratcheting sound is heard.

3. CHECK FUEL FILLER CAP FUNCTION

Check for air releasing sound while opening the fuel filler cap.

OK or NG

- OK >> GO TO 5.
- NG >> GO TO 4.

4. CHECK FUEL TANK VACUUM RELIEF VALVE

Refer to [EC-1323, "FUEL TANK VACUUM RELIEF VALVE \(BUILT INTO FUEL FULLER CAP\)"](#) .

OK or NG

- OK >> GO TO 5.
- NG >> Replace fuel filler cap with a genuine one.

5. INSTALL THE PRESSURE PUMP

To locate the EVAP leak, install EVAP service port adapter and pressure pump to EVAP service port securely. For the location of EVAP service port, refer to [EC-1321, "EVAPORATIVE EMISSION LINE DRAWING"](#).

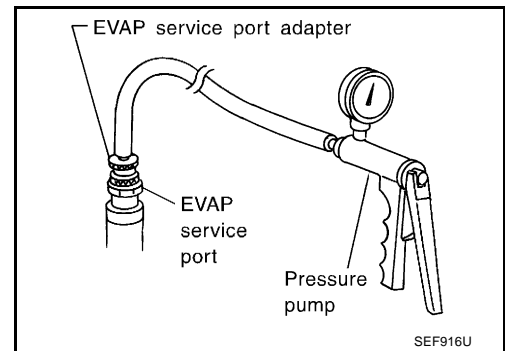
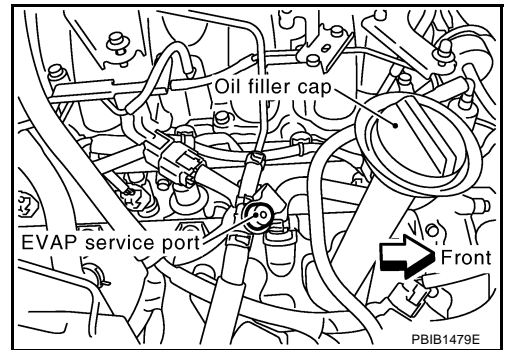

NOTE:

Improper installation of the EVAP service port adapter to the EVAP service port may cause leaking.

With CONSULT-II>>GO TO 6.
Without CONSULT-II>>GO TO 7.

6. CHECK FOR EVAP LEAK

With CONSULT-II

1. Turn ignition switch ON.
2. Select "EVAP SYSTEM CLOSE" of "WORK SUPPORT" mode with CONSULT-II.
3. Touch "START" and apply pressure into the EVAP line until the pressure indicator reaches the middle of the bar graph.

NOTE:

- Never use compressed air or a high pressure pump.
- Do not exceed 4.12 kPa (0.042 kg/cm² , 0.6 psi) of pressure in the system.

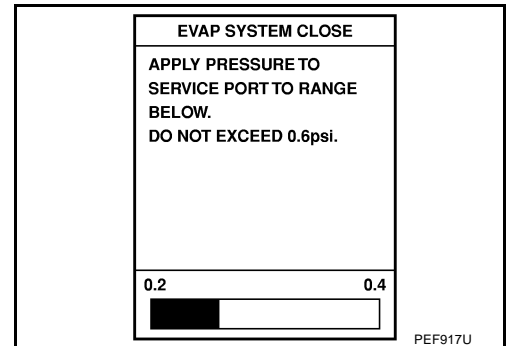

4. Using EVAP leak detector, locate the EVAP leak. For the leak detector, refer to the instruction manual for more details. Refer to [EC-1321, "EVAPORATIVE EMISSION LINE DRAWING"](#).

OK or NG

- OK >> GO TO 8.
NG >> Repair or replace.

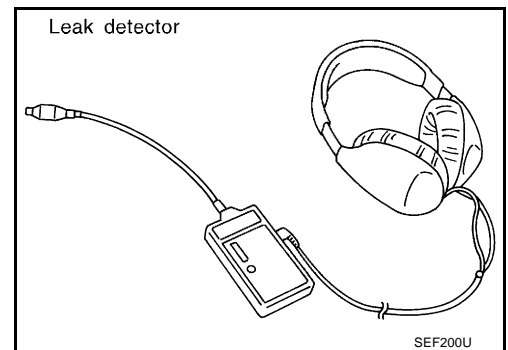

A
EC
C
D
E
F
G
H
I
J
K
L
M

7. CHECK FOR EVAP LEAK

⊗ Without CONSULT-II

1. Turn ignition switch OFF.
2. Apply 12 volts DC to EVAP canister vent control valve. The valve will close. (Continue to apply 12 volts until the end of test.)

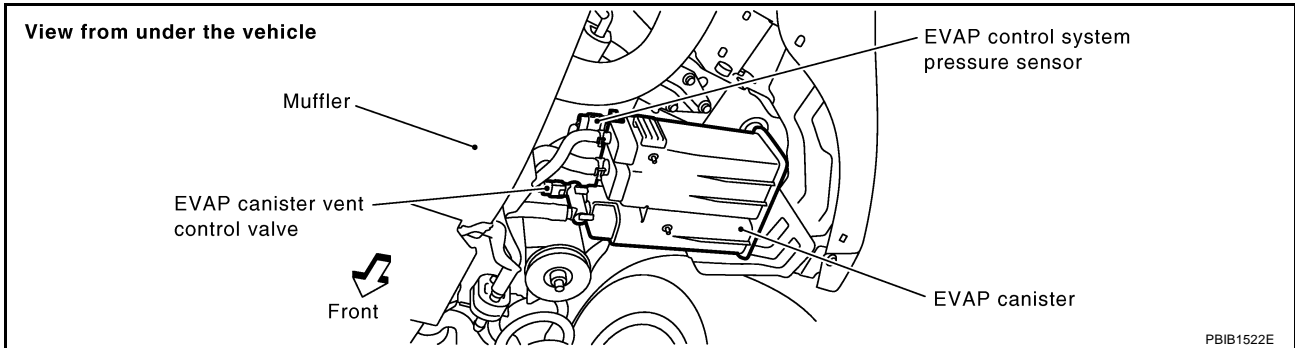

3. Pressurize the EVAP line using pressure pump with 1.3 to 2.7 kPa (10 to 20 mmHg, 0.39 to 0.79 inHg), then remove pump and EVAP service port adapter.

NOTE:

- Never use compressed air or a high pressure pump.
- Do not exceed 4.12 kPa (0.042 kg/cm², 0.6 psi) of pressure in the system.

4. Using EVAP leak detector, locate the EVAP leak. For the leak detector, refer to the instruction manual for more details. Refer to [EC-1321, "EVAPORATIVE EMISSION LINE DRAWING"](#).

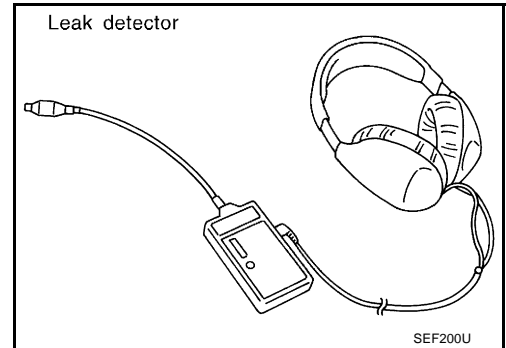

OK or NG

- OK >> GO TO 8.
 NG >> Repair or replace.

8. CHECK EVAP CANISTER VENT CONTROL VALVE

Check the following.

- EVAP canister vent control valve is installed properly.
Refer to [EC-1324, "Removal and Installation"](#).
- EVAP canister vent control valve.
Refer to [EC-1002, "Component Inspection"](#).

OK or NG

- OK >> GO TO 9.
 NG >> Repair or replace EVAP canister vent control valve and O-ring.

9. CHECK IF EVAP CANISTER SATURATED WITH WATER

1. Remove EVAP canister with EVAP canister vent control valve and EVAP control system pressure sensor attached.

2. Does water drain from the EVAP canister?

Yes or No

Yes >> GO TO 10.

No (With CONSULT-II)>>GO TO 12.

No (Without CONSULT-II)>>GO TO 13.

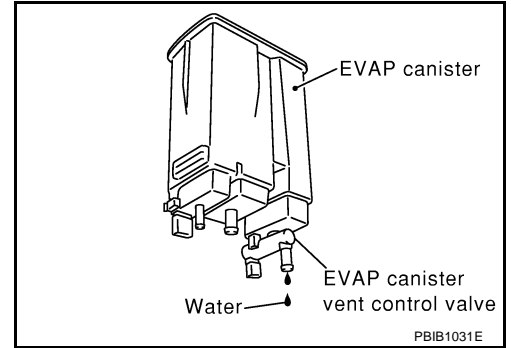

10. CHECK EVAP CANISTER

Weigh the EVAP canister with the EVAP canister vent control valve and EVAP control system pressure sensor attached.

The weight should be less than 2.1 kg (4.6 lb).

OK or NG

OK (With CONSULT-II)>>GO TO 12.

OK (Without CONSULT-II)>>GO TO 13.

NG >> GO TO 11.

11. DETECT MALFUNCTIONING PART

Check the following.

- EVAP canister for damage
- EVAP hose between EVAP canister and vehicle frame for clogging or poor connection

>> Repair hose or replace EVAP canister.

12. CHECK EVAP CANISTER PURGE VOLUME CONTROL SOLENOID VALVE OPERATION

Ⓟ With CONSULT-II

1. Disconnect vacuum hose to EVAP canister purge volume control solenoid valve at EVAP service port.
2. Start engine.
3. Perform "PURG VOL CONT/V" in "ACTIVE TEST" mode.
4. Touch "Qu" on CONSULT-II screen to increase "PURG VOL CONT/V" opening to 100%.
5. Check vacuum hose for vacuum when revving engine up to 2,000 rpm.

OK or NG

OK >> GO TO 15.

NG >> GO TO 14.

ACTIVE TEST	
PURG VOL CONT/V	XXX %
MONITOR	
ENG SPEED	XXX rpm
A/F ALPHA-B1	XX %
A/F ALPHA-B2	XX %

PBIB1678E

13. CHECK EVAP CANISTER PURGE VOLUME CONTROL SOLENOID VALVE OPERATION

⊗ **Without CONSULT-II**

1. Start engine and warm it up to normal operating temperature.
2. Stop engine.
3. Disconnect vacuum hose to EVAP canister purge volume control solenoid valve at EVAP service port.
4. Start engine and let it idle for at least 80 seconds.
5. Check vacuum hose for vacuum when revving engine up to 2,000 rpm.

Vacuum should exist.

OK or NG

- OK >> GO TO 16.
NG >> GO TO 14.

14. CHECK VACUUM HOSE

Check vacuum hoses for clogging or disconnection. Refer to [EC-677, "Vacuum Hose Drawing"](#) .

OK or NG

- OK >> GO TO 15.
NG >> Repair or reconnect the hose.

15. CHECK EVAP CANISTER PURGE VOLUME CONTROL SOLENOID VALVE

Refer to [EC-995, "Component Inspection"](#) .

OK or NG

- OK >> GO TO 16.
NG >> Replace EVAP canister purge volume control solenoid valve.

16. CHECK FUEL TANK TEMPERATURE SENSOR

Refer to [EC-936, "Component Inspection"](#) .

OK or NG

- OK >> GO TO 17.
NG >> Replace fuel level sensor unit.

17. CHECK EVAP CONTROL SYSTEM PRESSURE SENSOR

Refer to [EC-1013, "Component Inspection"](#) .

OK or NG

- OK >> GO TO 18.
NG >> Replace EVAP control system pressure sensor.

18. CHECK EVAP PURGE LINE

Check EVAP purge line (pipe, rubber tube, fuel tank and EVAP canister) for cracks or improper connection. Refer to [EC-1321, "EVAPORATIVE EMISSION LINE DRAWING"](#) .

OK or NG

- OK >> GO TO 19.
NG >> Repair or reconnect the hose.

19. CLEAN EVAP PURGE LINE

Clean EVAP purge line (pipe and rubber tube) using air blower.

>> GO TO 20.

20. CHECK EVAP/ORVR LINE

Check EVAP/ORVR line between EVAP canister and fuel tank for clogging, kink, looseness and improper connection. For location, refer to [EC-1327, "ON BOARD REFUELING VAPOR RECOVERY \(ORVR\)"](#) .

OK or NG

- OK >> GO TO 21.
- NG >> Repair or replace hoses and tubes.

21. CHECK RECIRCULATION LINE

Check recirculation line between filler neck tube and fuel tank for clogging, kink, cracks, looseness and improper connection.

OK or NG

- OK >> GO TO 22.
- NG >> Repair or replace hose, tube or filler neck tube.

22. CHECK REFUELING EVAP VAPOR CUT VALVE

Refer to [EC-1330, "REFUELING EVAP VAPOR CUT VALVE"](#) .

OK or NG

- OK >> GO TO 23.
- NG >> Replace refueling EVAP vapor cut valve with fuel tank.

23. CHECK FUEL LEVEL SENSOR

Refer to [DI-25, "CHECK FUEL LEVEL SENSOR UNIT"](#) .

OK or NG

- OK >> GO TO 24.
- NG >> Replace fuel level sensor unit.

24. CHECK INTERMITTENT INCIDENT

Refer to [EC-784, "TROUBLE DIAGNOSIS FOR INTERMITTENT INCIDENT"](#) .

>> **INSPECTION END**

A

EC

C

D

E

F

G

H

I

J

K

L

M

DTC P0444, P0445 EVAP CANISTER PURGE VOLUME CONTROL SOLENOID VALVE

[VK45DE]

DTC P0444, P0445 EVAP CANISTER PURGE VOLUME CONTROL SOLENOID VALVE

PFP:14920

Description SYSTEM DESCRIPTION

ABS00C5P

Sensor	Input signal to ECM	ECM function	Actuator
Crankshaft position sensor (POS) Camshaft position sensor (PHASE)	Engine speed* ¹	EVAP canister purge flow control	EVAP canister purge vol- ume control solenoid valve
Mass air flow sensor	Amount of intake air		
Engine coolant temperature sensor	Engine coolant temperature		
Battery	Battery voltage* ¹		
Throttle position sensor	Throttle position		
Accelerator pedal position sensor	Accelerator pedal position		
Heated oxygen sensors 1	Density of oxygen in exhaust gas (Mixture ratio feedback signal)		
Fuel tank temperature sensor	Fuel temperature in fuel tank		
Wheel sensor* ²	Vehicle speed		

*1:ECM determines the start signal status by the signals of engine speed and battery voltage.

*2: This signal is sent to the ECM through CAN communication line.

This system controls flow rate of fuel vapor from the EVAP canister. The opening of the vapor by-pass passage in the EVAP canister purge volume control solenoid valve changes to control the flow rate. The EVAP canister purge volume control solenoid valve repeats ON/OFF operation according to the signal sent from the ECM. The opening of the valve varies for optimum engine control. The optimum value stored in the ECM is determined by considering various engine conditions. When the engine is operating, the flow rate of fuel vapor from the EVAP canister is regulated as the air flow changes.

COMPONENT DESCRIPTION

The EVAP canister purge volume control solenoid valve uses a ON/OFF duty to control the flow rate of fuel vapor from the EVAP canister. The EVAP canister purge volume control solenoid valve is moved by ON/OFF pulses from the ECM. The longer the ON pulse, the greater the amount of fuel vapor that will flow through the valve.

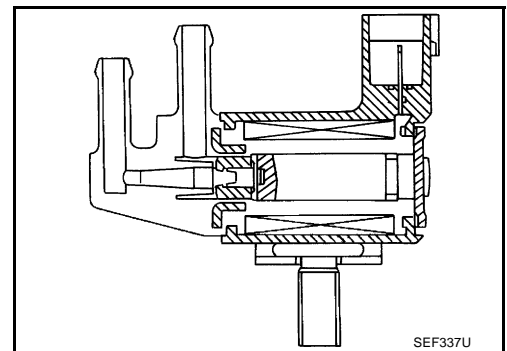

CONSULT-II Reference Value in Data Monitor Mode

ABS00C5Q

Specification data are reference values.

MONITOR ITEM	CONDITION	SPECIFICATION
PURG VOL C/V	● Engine: After warming up ● Air conditioner switch: OFF	Idle
	● Shift lever: N ● No load	2,000 rpm
		0%
		—

DTC P0444, P0445 EVAP CANISTER PURGE VOLUME CONTROL SOLENOID VALVE

[VK45DE]

On Board Diagnosis Logic

ABS00C5R

DTC No.	Trouble diagnosis name	DTC detecting condition	Possible cause
P0444 0444	EVAP canister purge volume control solenoid valve circuit open	An excessively low voltage signal is sent to ECM through the valve	<ul style="list-style-type: none"> ● Harness or connectors (The solenoid valve circuit is open or shorted.) ● EVAP canister purge volume control solenoid valve
P0445 0445	EVAP canister purge volume control solenoid valve circuit shorted	An excessively high voltage signal is sent to ECM through the valve	<ul style="list-style-type: none"> ● Harness or connectors (The solenoid valve circuit is shorted.) ● EVAP canister purge volume control solenoid valve

DTC Confirmation Procedure

ABS00C5S

NOTE:

If DTC Confirmation Procedure has been previously conducted, always turn ignition switch OFF and wait at least 10 seconds before conducting the next test.

TESTING CONDITION:

Before performing the following procedure, confirm battery voltage is more than 11V at idle.

WITH CONSULT-II

1. Turn ignition switch ON.
2. Select "DATA MONITOR" mode with CONSULT-II.
3. Start engine and let it idle for at least 13 seconds.
4. If 1st trip DTC is detected, go to [EC-994, "Diagnostic Procedure"](#)

DATA MONITOR	
MONITOR	NO DTC
ENG SPEED	XXX rpm

SEF058Y

WITH GST

Follow the procedure "WITH CONSULT-II" above.

DTC P0444, P0445 EVAP CANISTER PURGE VOLUME CONTROL SOLENOID VALVE

[VK45DE]

ABS00C5T

Wiring Diagram

EC-PGC/V-01

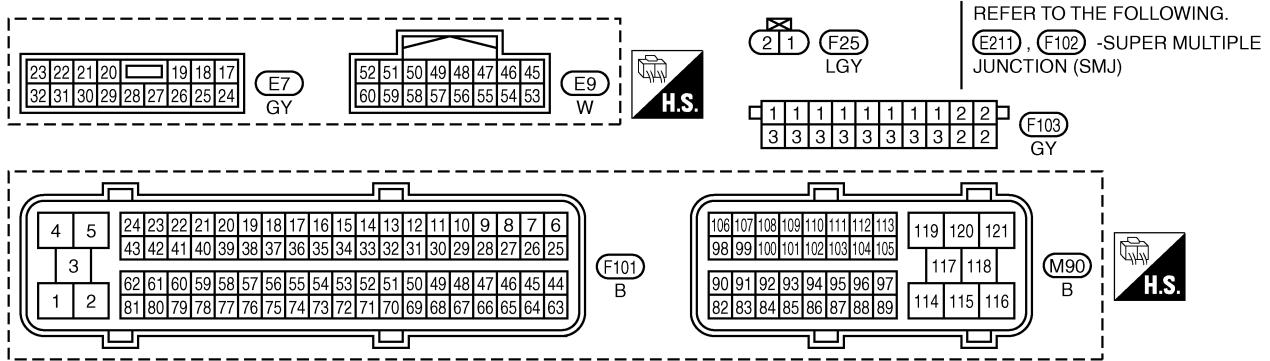
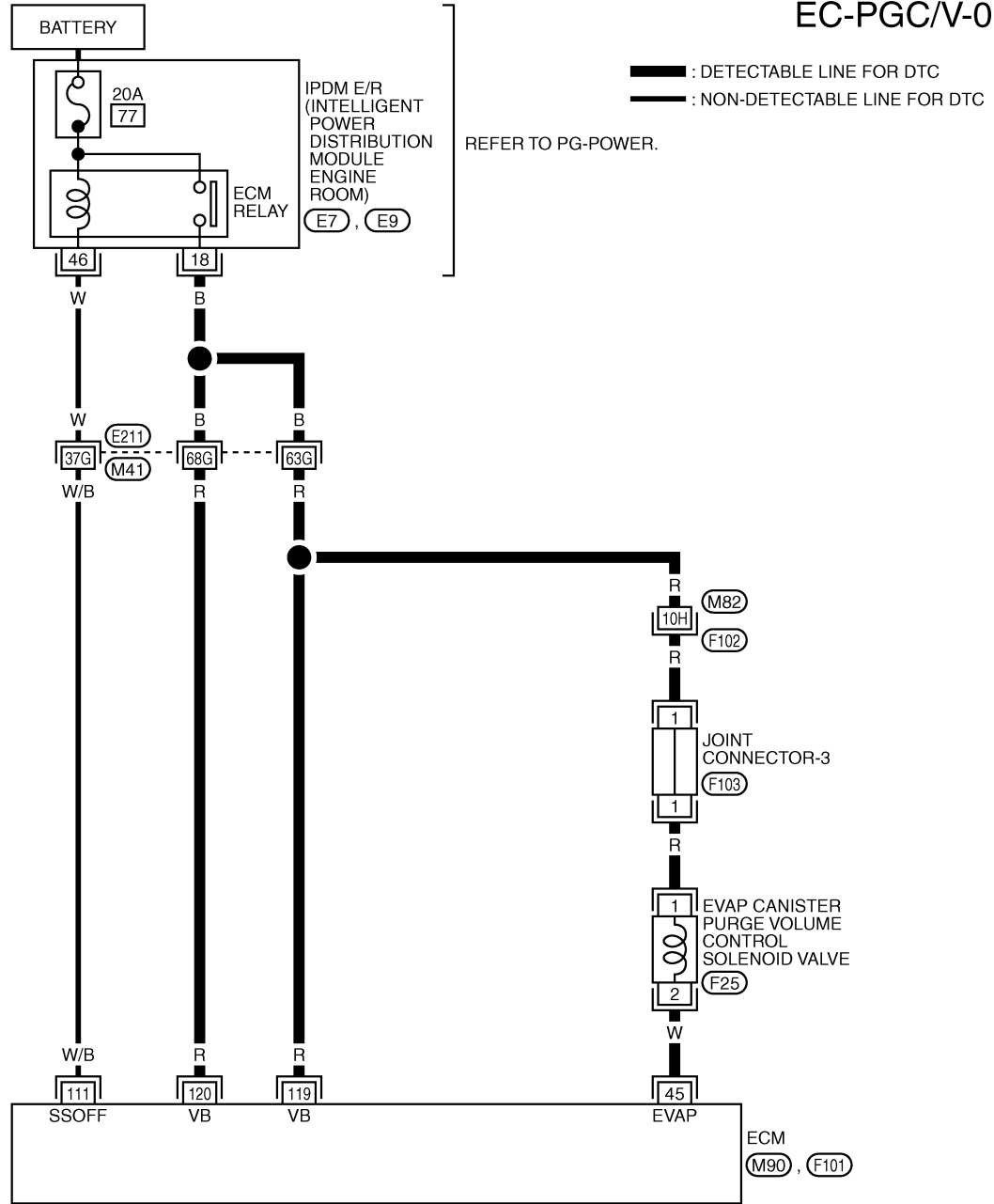

TBWM0246E

DTC P0444, P0445 EVAP CANISTER PURGE VOLUME CONTROL SOLENOID VALVE

[VK45DE]

Specification data are reference values and are measured between each terminal and ground.
Pulse signal is measured by CONSULT-II.

CAUTION:

Do not use ECM ground terminals when measuring input/output voltage. Doing so may result in damage to the ECM's transistor. Use a ground other than ECM terminals, such as the ground.

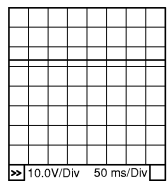
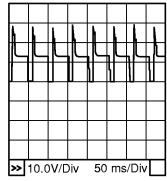
TER-MINAL NO.	WIRE COLOR	ITEM	CONDITION	DATA (DC Voltage)
45	W	EVAP canister purge volume control solenoid valve	[Engine is running] <ul style="list-style-type: none"> ● Idle speed 	BATTERY VOLTAGE (11 - 14V) [★]  <small>10.0V/Div 50 ms/Div</small> PBIB0050E
			[Engine is running] <ul style="list-style-type: none"> ● Engine speed is about 2,000 rpm (More than 100 seconds after starting engine) 	11 - 14V [★]  <small>10.0V/Div 50 ms/Div</small> PBIB0051E
111	W/B	ECM relay (Self shut-off)	[Engine is running] [Ignition switch: OFF] <ul style="list-style-type: none"> ● For a few seconds after turning ignition switch OFF 	0 - 1.5V
			[Ignition switch: OFF] <ul style="list-style-type: none"> ● More than a few seconds after turning ignition switch OFF 	BATTERY VOLTAGE (11 - 14V)
119 120	R R	Power supply for ECM	[Ignition switch: ON]	BATTERY VOLTAGE (11 - 14V)

★: Average voltage for pulse signal (Actual pulse signal can be confirmed by oscilloscope.)

Diagnostic Procedure

1. CHECK EVAP CANISTER PURGE VOLUME CONTROL SOLENOID VALVE POWER SUPPLY CIRCUIT

1. Turn ignition switch OFF.
2. Disconnect EVAP canister purge volume control solenoid valve harness connector.
3. Turn ignition switch ON.

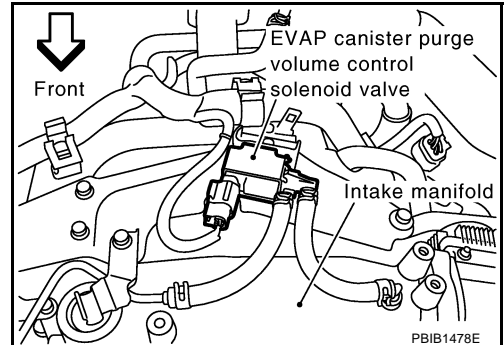

4. Check voltage between EVAP canister purge volume control solenoid valve terminal 1 and ground with CONSULT-II or tester.

Voltage: Battery voltage

OK or NG

- OK >> GO TO 3.
 NG >> GO TO 2.

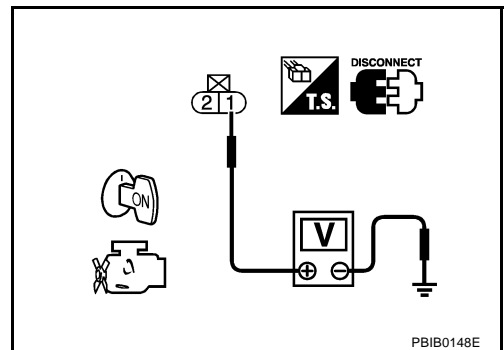

2. DETECT MALFUNCTIONING PART

Check the following.

- Harness connectors E211, M41
- Harness connectors M82, F102
- Joint connector-3
- Harness for open or short between EVAP canister purge volume control solenoid valve and IPDM E/R
- Harness for open or short between EVAP canister purge volume control solenoid valve and ECM

>> Repair open circuit or short to ground or short to power in harness or connectors.

3. CHECK EVAP CANISTER PURGE VOLUME CONTROL SOLENOID VALVE OUTPUT SIGNAL CIRCUIT FOR OPEN AND SHORT

1. Turn ignition switch OFF.
2. Disconnect ECM harness connector.
3. Check harness continuity between ECM terminal 45 and EVAP canister purge volume control solenoid valve terminal 2. Refer to Wiring Diagram.

Continuity should exist.

4. Also check harness for short to ground and short to power.

OK or NG

- OK (With CONSULT-II)>>GO TO 4.
 OK (Without CONSULT-II)>>GO TO 5.
 NG >> Repair open circuit or short to ground or short to power in harness or connectors.

4. CHECK EVAP CANISTER PURGE VOLUME CONTROL SOLENOID VALVE OPERATION

With CONSULT-II

1. Reconnect all harness connectors disconnected.
2. Start engine.
3. Perform "PURG VOL CONT/V" in "ACTIVE TEST" mode with CONSULT-II. Check that engine speed varies according to the valve opening.

OK or NG

- OK >> GO TO 6.
 NG >> GO TO 5.

ACTIVE TEST	
PURG VOL CONT/V	XXX %
MONITOR	
ENG SPEED	XXX rpm
A/F ALPHA-B1	XX %
A/F ALPHA-B2	XX %

PBIB1678E

5. CHECK EVAP CANISTER PURGE VOLUME CONTROL SOLENOID VALVE

Refer to [EC-995, "Component Inspection"](#) .

OK or NG

- OK >> GO TO 6.
 NG >> Replace EVAP canister purge volume control solenoid valve.

6. CHECK INTERMITTENT INCIDENT

Refer to [EC-784, "TROUBLE DIAGNOSIS FOR INTERMITTENT INCIDENT"](#) .

>> INSPECTION END

Component Inspection EVAP CANISTER PURGE VOLUME CONTROL SOLENOID VALVE

ABS00C5V

With CONSULT-II

Check air passage continuity of EVAP canister purge volume control solenoid valve under the following conditions.

Condition (PURG VOL CONT/V value)	Air passage continuity between A and B
100%	Yes
0%	No

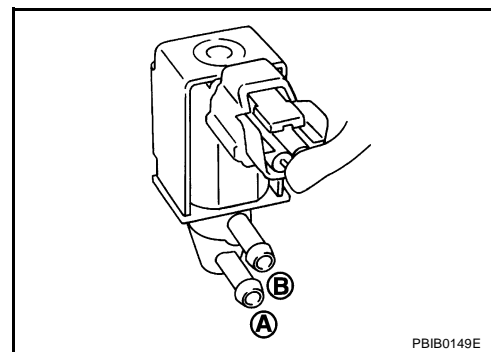

Without CONSULT-II

Check air passage continuity of EVAP canister purge volume control solenoid valve under the following conditions.

Condition	Air passage continuity between A and B
12V direct current supply between terminals 1 and 2	Yes
No supply	No

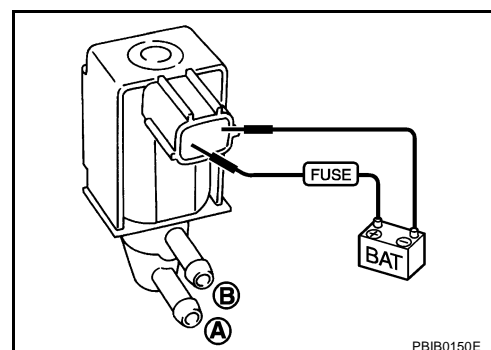

DTC P0444, P0445 EVAP CANISTER PURGE VOLUME CONTROL SOLENOID VALVE

[VK45DE]

Removal and Installation

EVAP CANISTER PURGE VOLUME CONTROL SOLENOID VALVE

ABS00C5W

Refer to [EM-174, "INTAKE MANIFOLD"](#) .

DTC P0447 EVAP CANISTER VENT CONTROL VALVE

PF0:14935

Component Description

ABS00C5X

The EVAP canister vent control valve is located on the EVAP canister and is used to seal the canister vent.

This solenoid valve responds to signals from the ECM. When the ECM sends an ON signal, the coil in the solenoid valve is energized. A plunger will then move to seal the canister vent. The ability to seal the vent is necessary for the on board diagnosis of other evaporative emission control system components.

This solenoid valve is used only for diagnosis, and usually remains opened.

When the vent is closed, under normal purge conditions, the evaporative emission control system is depressurized and allows "EVAP Control System" diagnosis.

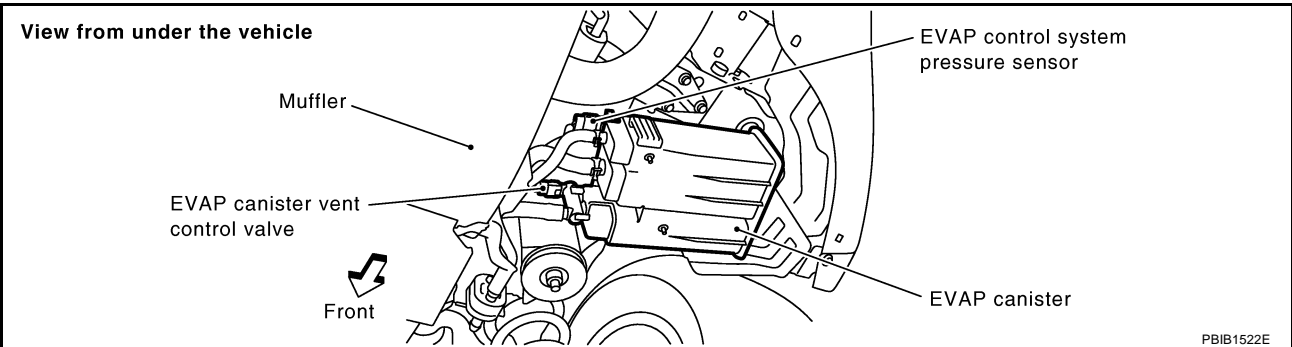
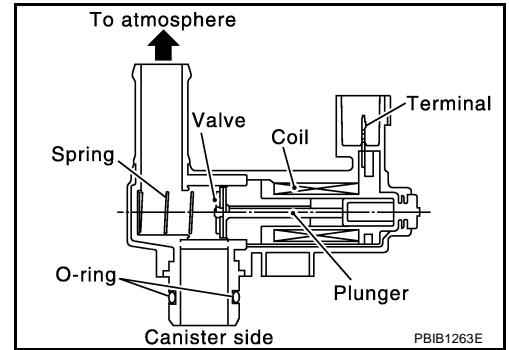

CONSULT-II Reference Value in Data Monitor Mode

ABS00C5Y

Specification data are reference values.

MONITOR ITEM	CONDITION	SPECIFICATION
VENT CONT/V	● Ignition switch: ON	OFF

On Board Diagnosis Logic

ABS00C5Z

DTC No.	Trouble diagnosis name	DTC detecting condition	Possible cause
P0447 0447	EVAP canister vent control valve circuit open	An improper voltage signal is sent to ECM through EVAP canister vent control valve.	<ul style="list-style-type: none"> ● Harness or connectors (The valve circuit is open or shorted.) ● EVAP canister vent control valve

DTC Confirmation Procedure

NOTE:

If DTC Confirmation Procedure has been previously conducted, always turn ignition switch OFF and wait at least 10 seconds before conducting the next test.

TESTING CONDITION:

Before performing the following procedure, confirm battery voltage is more than 11V at idle.

WITH CONSULT-II

1. Turn ignition switch ON.
2. Select "DATA MONITOR" mode with CONSULT-II.
3. Start engine and wait at least 8 seconds.
4. If 1st trip DTC is detected, go to [EC-1000, "Diagnostic Procedure"](#).

DATA MONITOR	
MONITOR	NO DTC
ENG SPEED	XXX rpm

SEF058Y

WITH GST

Follow the procedure "WITH CONSULT-II" above.

DTC P0447 EVAP CANISTER VENT CONTROL VALVE

[VK45DE]

ABS00C61

Wiring Diagram

EC-VENT/V-01

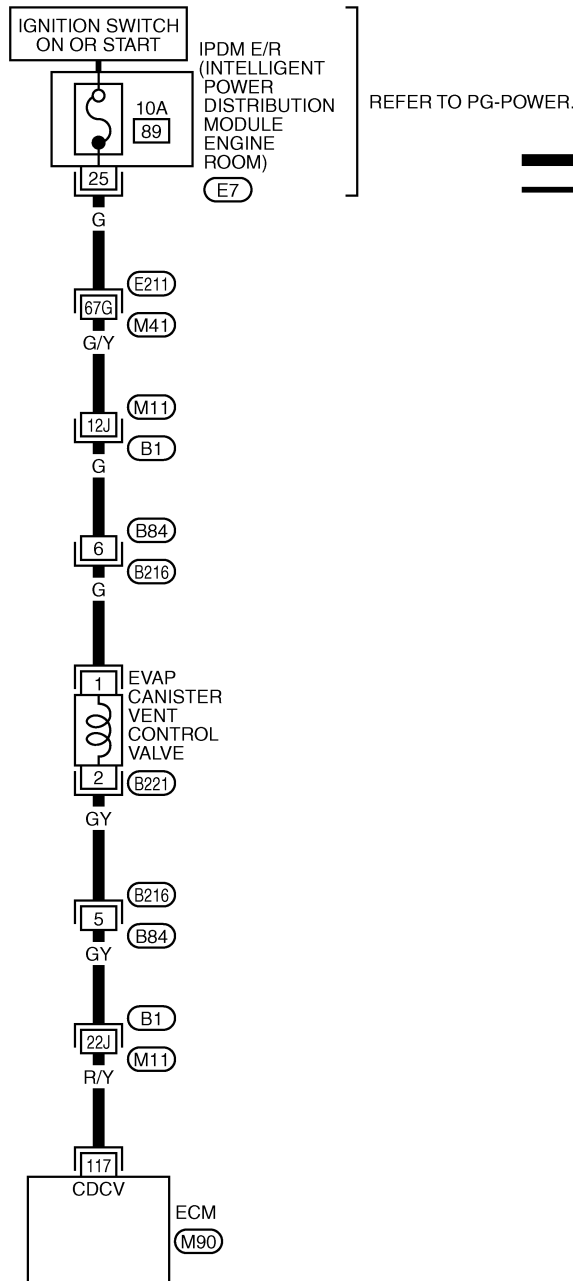

— : DETECTABLE LINE FOR DTC
 — : NON-DETECTABLE LINE FOR DTC

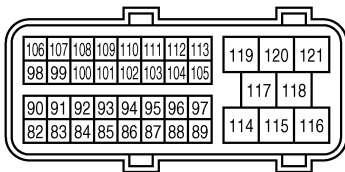

M90 B

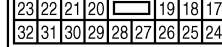

E7 GY

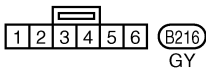

REFER TO THE FOLLOWING.
 (E211), (B1) -SUPER MULTIPLE JUNCTION (SMJ)

TBWH0110E

DTC P0447 EVAP CANISTER VENT CONTROL VALVE

[VK45DE]

Specification data are reference values and are measured between each terminal and ground.

CAUTION:

Do not use ECM ground terminals when measuring input/output voltage. Doing so may result in damage to the ECM's transistor. Use a ground other than ECM terminals, such as the ground.

TER-MINAL NO.	WIRE COLOR	ITEM	CONDITION	DATA (DC Voltage)
117	R/Y	EVAP canister vent control valve	[Ignition switch: ON]	BATTERY VOLTAGE (11 - 14V)

Diagnostic Procedure

ABS00C62

1. INSPECTION START

Do you have CONSULT-II?

Yes or No

- Yes >> GO TO 2.
- No >> GO TO 3.

2. CHECK EVAP CANISTER VENT CONTROL VALVE CIRCUIT

④ With CONSULT-II

1. Turn ignition switch OFF and then turn ON.
2. Select "VENT CONTROL/V" in "ACTIVE TEST" mode with CONSULT-II.
3. Touch "ON/OFF" on CONSULT-II screen.
4. Check for operating sound of the valve.

Clicking noise should be heard.

OK or NG

- OK >> GO TO 7.
- NG >> GO TO 3.

ACTIVE TEST	
VENT CONTROL/V	OFF
MONITOR	
ENG SPEED	XXX rpm
A/F ALPHA-B1	XXX %
A/F ALPHA-B2	XXX %
HO2S1 (B1)	XXX V
HO2S1 (B2)	XXX V

PBIB0151E

3. CHECK EVAP CANISTER VENT CONTROL VALVE POWER SUPPLY CIRCUIT

1. Turn ignition switch OFF.
2. Disconnect EVAP canister vent control valve harness connector.

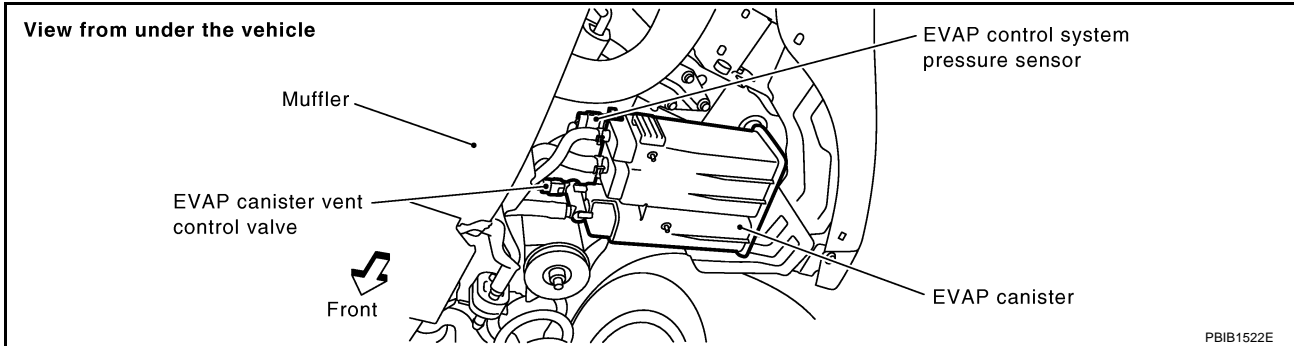

3. Turn ignition switch ON.
4. Check voltage between EVAP canister vent control valve terminal 1 and ground with CONSULT-II or tester.

Voltage: Battery voltage

OK or NG

- OK >> GO TO 5.
- NG >> GO TO 4.

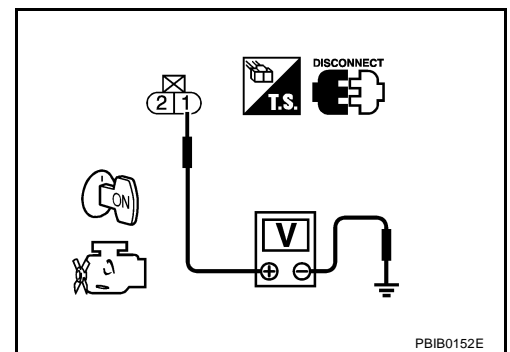

4. DETECT MALFUNCTIONING PART

Check the following.

- Harness connectors E211, M41
- Harness connectors M11, B1
- Harness connectors B84, B216
- IPDM E/R harness connector E7
- 10A fuse
- Harness for open or short between EVAP canister vent control valve and IPDM E/R

>> Repair open circuit or short to ground or short to power in harness or connectors.

5. CHECK EVAP CANISTER VENT CONTROL VALVE OUTPUT SIGNAL CIRCUIT FOR OPEN AND SHORT

1. Turn ignition switch OFF.
2. Disconnect ECM harness connector.
3. Check harness continuity between ECM terminal 117 and EVAP canister vent control valve terminal 2. Refer to Wiring Diagram.

Continuity should exist.

4. Also check harness for short to ground and short to power.

OK or NG

- OK >> GO TO 7.
- NG >> GO TO 6.

6. DETECT MALFUNCTIONING PART

Check the following.

- Harness connectors B216, B84
- Harness connectors M11, B1
- Harness for open or short between EVAP canister vent control valve and ECM

>> Repair open circuit or short to ground or short to power in harness or connectors.

7. CHECK RUBBER TUBE FOR CLOGGING

1. Disconnect rubber tube connected to EVAP canister vent control valve.
2. Check the rubber tube for clogging.

OK or NG

OK >> GO TO 8.

NG >> Clean the rubber tube using an air blower.

8. CHECK EVAP CANISTER VENT CONTROL VALVE

Refer to [EC-1002, "Component Inspection"](#) .

OK or NG

OK >> GO TO 9.

NG >> Replace EVAP canister vent control valve.

9. CHECK INTERMITTENT INCIDENT

Refer to [EC-784, "TROUBLE DIAGNOSIS FOR INTERMITTENT INCIDENT"](#) .

>> INSPECTION END

Component Inspection EVAP CANISTER VENT CONTROL VALVE

ABS00C63

Ⓟ With CONSULT-II

1. Remove EVAP canister vent control valve from EVAP canister.
2. Check portion **B** of EVAP canister vent control valve for being rusted.
If NG, replace EVAP canister vent control valve.
If OK, go to next step.
3. Reconnect harness connectors disconnected.
4. Turn ignition switch ON.

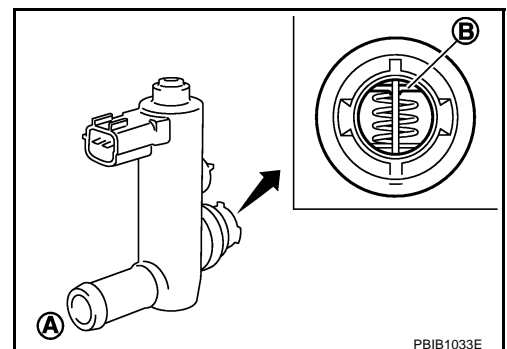

PBIB1033E

DTC P0447 EVAP CANISTER VENT CONTROL VALVE

[VK45DE]

5. Perform "VENT CONTROL/V" in "ACTIVE TEST" mode.
6. Check air passage continuity and operation delay time.
Make sure new O-ring is installed properly.

Condition VENT CONTROL/V	Air passage continuity between A and B
ON	No
OFF	Yes

Operation takes less than 1 second.

If NG, replace EVAP canister vent control valve.
If OK, go to next step.

7. Clean the air passage (portion **A** to **B**) of EVAP canister vent control valve using an air blower.
8. Perform step 6 again.

⊗ **Without CONSULT-II**

1. Remove EVAP canister vent control valve from EVAP canister.
2. Check portion **B** of EVAP canister vent control valve for being rusted.

ACTIVE TEST	
VENT CONTROL/V	OFF
MONITOR	
ENG SPEED	XXX rpm
A/F ALPHA-B1	XXX %
A/F ALPHA-B2	XXX %
HO2S1 (B1)	XXX V
HO2S1 (B2)	XXX V

PBIB0151E

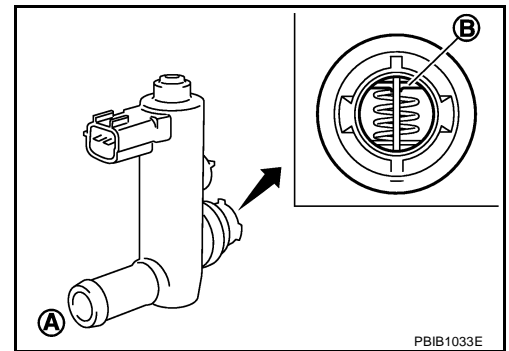

3. Check air passage continuity and operation delay time under the following conditions.
Make sure new O-ring is installed properly.

Condition	Air passage continuity between A and B
12V direct current supply between terminals 1 and 2	No
OFF	Yes

Operation takes less than 1 second.

If NG, replace EVAP canister vent control valve.
If OK, go to next step.

4. Clean the air passage (portion **A** to **B**) of EVAP canister vent control valve using an air blower.
5. Perform step 3 again.

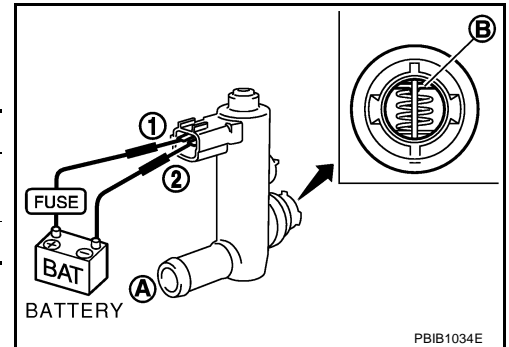

DTC P0451 EVAP CONTROL SYSTEM PRESSURE SENSOR

[VK45DE]

DTC P0451 EVAP CONTROL SYSTEM PRESSURE SENSOR

PFP:22365

Component Description

ABS00C64

The EVAP control system pressure sensor detects pressure in the purge line. The sensor output voltage to the ECM increases as pressure increases.

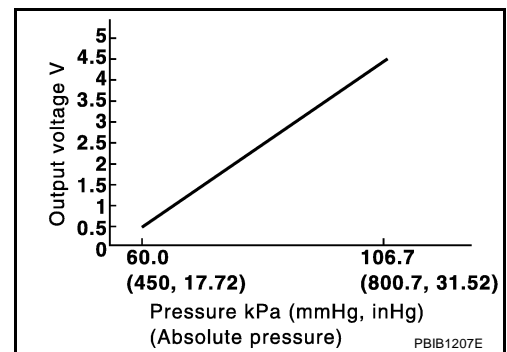
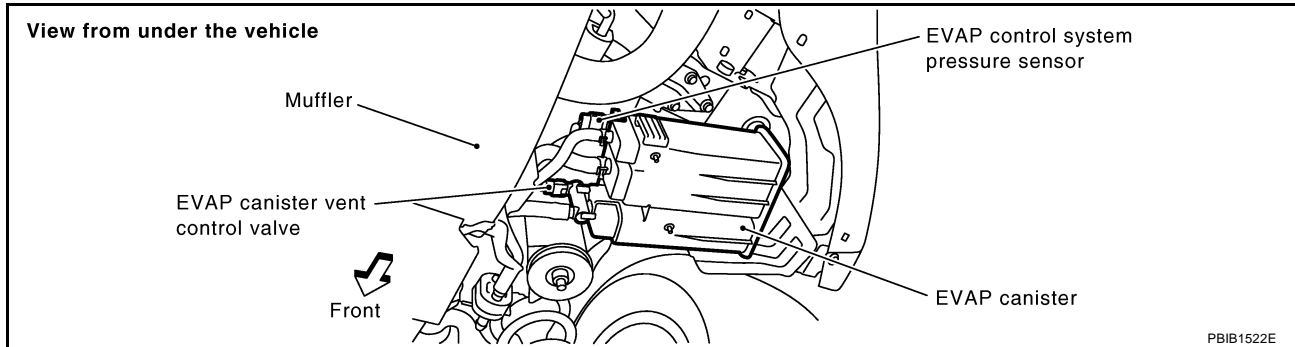

CONSULT-II Reference Value in Data Monitor Mode

ABS00C65

Specification data are reference values.

MONITOR ITEM	CONDITION	SPECIFICATION
EVAP SYS PRES	● Ignition switch: ON	Approx. 1.8 - 4.8V

On Board Diagnosis Logic

ABS00C66

NOTE:

If DTC P0451 is displayed with DTC P1229, first perform the trouble diagnosis for DTC P1229. Refer to [EC-1156](#).

DTC No.	Trouble diagnosis name	DTC detecting condition	Possible cause
P0451 0451	EVAP control system pressure sensor performance	ECM detects a sloshing signal from the EVAP control system pressure sensor	<ul style="list-style-type: none"> ● Harness or connectors ● EVAP control system pressure sensor

DTC Confirmation Procedure

NOTE:

If DTC Confirmation Procedure has been previously conducted, always turn ignition switch OFF and wait at least 10 seconds before conducting the next test.

Ⓟ WITH CONSULT-II

1. Turn ignition switch OFF and wait at least 10 seconds.
2. Turn ignition switch ON and select "DATA MONITOR" mode with CONSULT-II.
3. Start engine and wait at least 40 seconds.

NOTE:

Do not depress accelerator pedal even slightly.

If 1st trip DTC is detected, go to [EC-1005, "Diagnostic Procedure"](#).

DATA MONITOR	
MONITOR	NO DTC
ENG SPEED	XXX rpm
COOLAN TEMP/S	XXX °C
FUEL T/TMP SE	XXX °C

SEF194Y

Ⓟ WITH GST

Follow the procedure "WITH CONSULT-II" above.

Diagnostic Procedure

1. CHECK GROUND CONNECTIONS

1. Turn ignition switch OFF.
2. Loosen and retighten three ground screws on the body.
Refer to [EC-791, "Ground Inspection"](#).

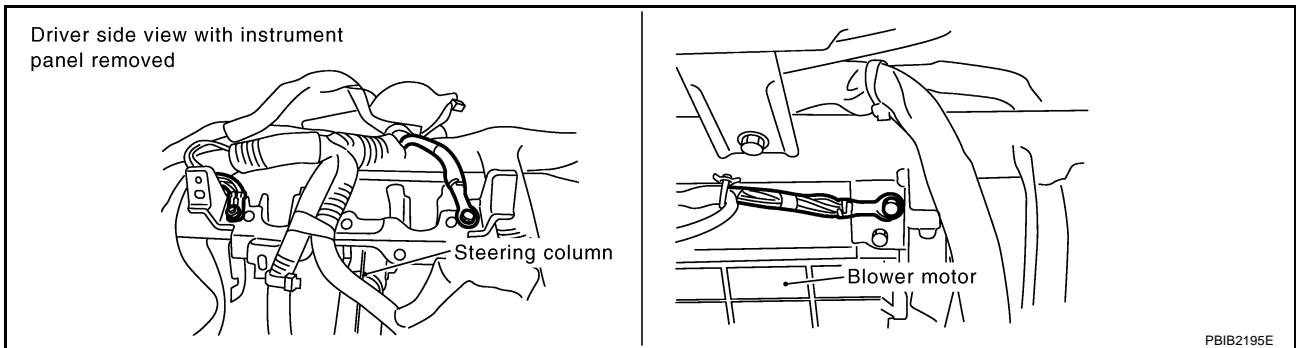

OK or NG

- OK >> GO TO 2.
- NG >> Repair or replace ground connections.

2. CHECK EVPA CONTROL SYSTEM PRESSURE SENSOR CONNECTOR FOR WATER

1. Disconnect EVAP control system pressure sensor harness connector.

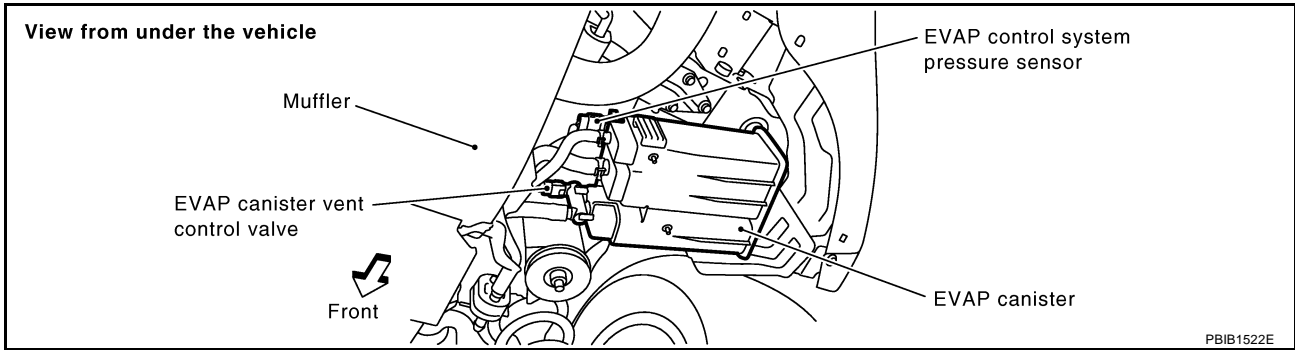

2. Check sensor harness connector for water.

Water should not exist.

OK or NG

OK >> GO TO 3.

NG >> Repair or replace harness connector.

3. CHECK EVAP CONTROL SYSTEM PRESSURE SENSOR

Refer to [EC-1006, "Component Inspection"](#) .

OK or NG

OK >> GO TO 4.

NG >> Replace EVAP control system pressure sensor.

4. CHECK INTERMITTENT INCIDENT

Refer to [EC-784, "TROUBLE DIAGNOSIS FOR INTERMITTENT INCIDENT"](#) .

For Wiring Diagram, refer to [EC-1009](#) .

>> INSPECTION END

Component Inspection EVAP CONTROL SYSTEM PRESSURE SENSOR

ABS00C69

1. Remove EVAP control system pressure sensor with its harness connector connected from EVAP canister. **Always replace O-ring with a new one.**
2. Install a vacuum pump to EVAP control system pressure sensor.
3. Turn ignition switch ON and check output voltage between ECM terminal 32 and ground under the following conditions.

Applied vacuum kPa (mmHg, inHg)	Voltage V
Not applied	1.8 - 4.8
-26.7 (-200, -7.87)	2.1 to 2.5V lower than above value

CAUTION:

- Always calibrate the vacuum pump gauge when using it.
 - Do not apply below -93.3 kPa (-700 mmHg, -27.56 inHg) or pressure over 101.3 kPa (760 mmHg, 29.92 inHg).
4. If NG, replace EVAP control system pressure sensor.

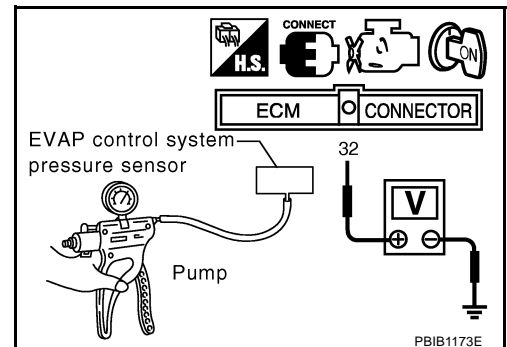

DTC P0452 EVAP CONTROL SYSTEM PRESSURE SENSOR

[VK45DE]

DTC P0452 EVAP CONTROL SYSTEM PRESSURE SENSOR

PFP:25085

Component Description

ABS00C6A

The EVAP control system pressure sensor detects pressure in the purge line. The sensor output voltage to the ECM increases as pressure increases.

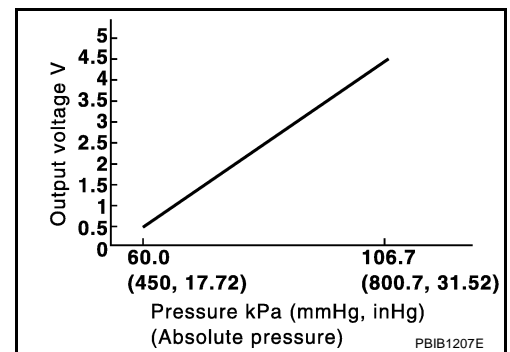
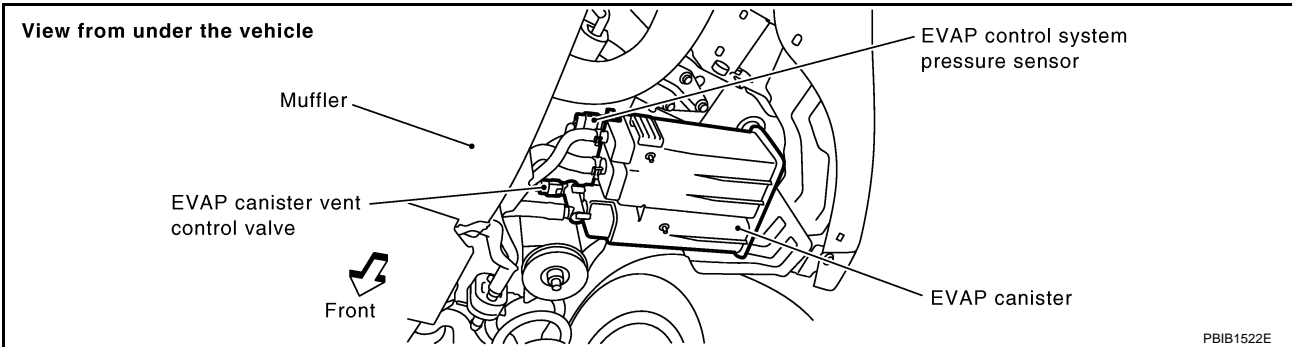

CONSULT-II Reference Value in Data Monitor Mode

ABS00C6B

Specification data are reference values.

MONITOR ITEM	CONDITION	SPECIFICATION
EVAP SYS PRES	● Ignition switch: ON	Approx. 1.8 - 4.8V

On Board Diagnosis Logic

ABS00C6C

NOTE:

If DTC P0452 is displayed with DTC P1229, first perform the trouble diagnosis for DTC P1229. Refer to [EC-1156](#).

DTC No.	Trouble diagnosis name	DTC detecting condition	Possible cause
P0452 0452	EVAP control system pressure sensor low input	An excessively low voltage from the sensor is sent to ECM.	<ul style="list-style-type: none"> ● Harness or connectors (The sensor circuit is open or shorted.) ● EVAP control system pressure sensor

DTC Confirmation Procedure

NOTE:

If DTC Confirmation Procedure has been previously conducted, always turn ignition switch OFF and wait at least 10 seconds before conducting the next test.

TESTING CONDITION:

Always perform test at a temperature of 5°C (41°F) or more.

WITH CONSULT-II

1. Start engine and warm it up to normal operating temperature.
2. Turn ignition switch OFF and wait at least 10 seconds.
3. Turn ignition switch ON.
4. Select "DATA MONITOR" mode with CONSULT-II.
5. Make sure that "FUEL T/TEMP SE" is more than 0°C (32°F).
6. Start engine and wait at least 20 seconds.
If 1st trip DTC is detected, go to [EC-1010, "Diagnostic Procedure"](#).

DATA MONITOR	
MONITOR	NO DTC
ENG SPEED	XXX rpm
COOLAN TEMP/S	XXX °C
FUEL T/TMP SE	XXX °C

SEF194Y

WITH GST

1. Start engine and warm it up to normal operating temperature.
2. Check that voltage between ECM terminal 107 (Fuel tank temperature sensor signal) and ground is less than 4.2V.
3. Turn ignition switch OFF and wait at least 10 seconds.
4. Start engine and wait at least 20 seconds.
5. Select MODE 7 with GST.
If 1st trip DTC is detected, go to [EC-1010, "Diagnostic Procedure"](#).

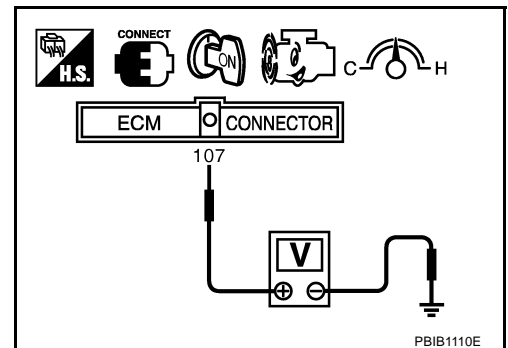

DTC P0452 EVAP CONTROL SYSTEM PRESSURE SENSOR

[VK45DE]

Wiring Diagram

ABS00C6E

EC-PRE/SE-01

— : DETECTABLE LINE FOR DTC

— : NON-DETECTABLE LINE FOR DTC

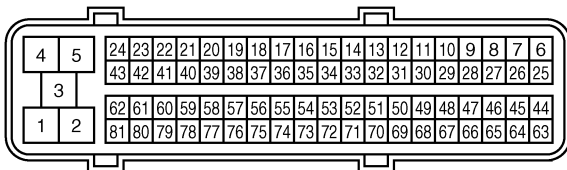
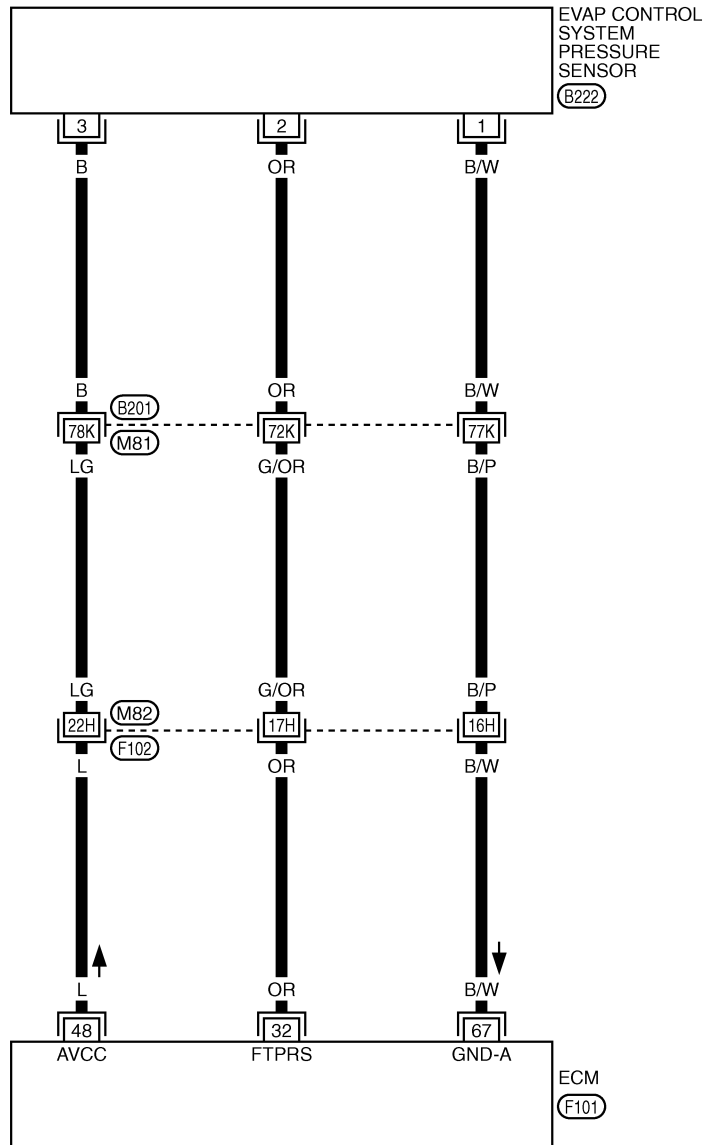

(F101)
B



(3 2 1) (B222)
GY

REFER TO THE FOLLOWING.

(F102), (B201) -SUPER MULTIPLE JUNCTION (SMJ)

TBWH0115E

DTC P0452 EVAP CONTROL SYSTEM PRESSURE SENSOR

[VK45DE]

Specification data are reference values and are measured between each terminal and ground.

CAUTION:

Do not use ECM ground terminals when measuring input/output voltage. Doing so may result in damage to the ECM's transistor. Use a ground other than ECM terminals, such as the ground.

TERMINAL NO.	WIRE COLOR	ITEM	CONDITION	DATA (DC Voltage)
32	OR	EVAP control system pressure sensor	[Ignition switch: ON]	Approximately 1.8 - 4.8V
48	L	Sensor power supply (Mass air flow sensor / EVAP control system pressure sensor)	[Ignition switch: ON]	Approximately 5V
67	B/W	Sensor ground (Mass air flow sensor / IAT sensor / Power steering pressure sensor / EVAP control system pressure sensor / Refrigerant pressure sensor / ECT sensor)	[Engine is running] ● Warm-up condition ● Idle speed	Approximately 0V

Diagnostic Procedure

ABS00C6F

1. CHECK GROUND CONNECTIONS

1. Turn ignition switch OFF.
2. Loosen and retighten three ground screws on the body.
Refer to [EC-791, "Ground Inspection"](#).

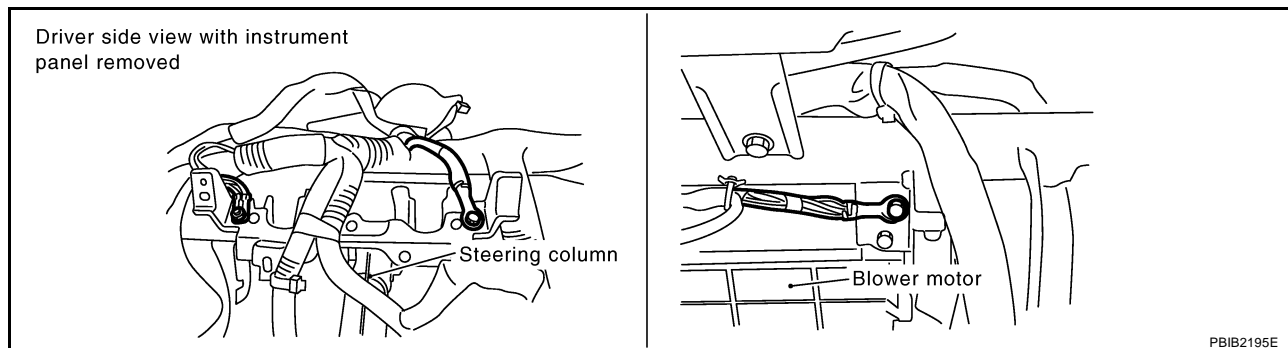

OK or NG

- OK >> GO TO 2.
 NG >> Repair or replace ground connections.

2. CHECK CONNECTOR

1. Disconnect EVAP control system pressure sensor harness connector.

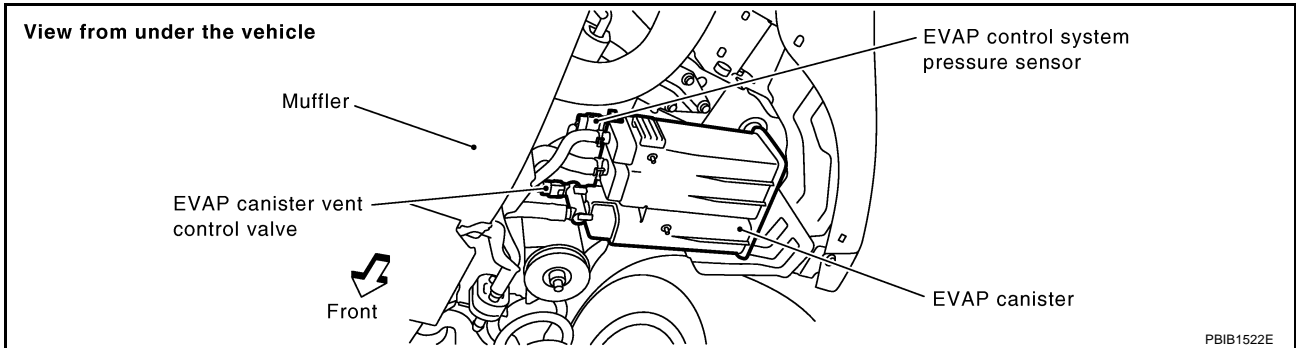

2. Check sensor harness connector for water.

Water should not exist.

OK or NG

- OK >> GO TO 3.
- NG >> Repair or replace harness connector.

3. CHECK EVAP CONTROL SYSTEM PRESSURE SENSOR POWER SUPPLY CIRCUIT

1. Turn ignition switch ON.
2. Check voltage between EVAP control system pressure sensor terminal 3 and ground with CONSULT-II or tester.

Voltage: Approximately 5V

OK or NG

- OK >> GO TO 5.
- NG >> GO TO 4.

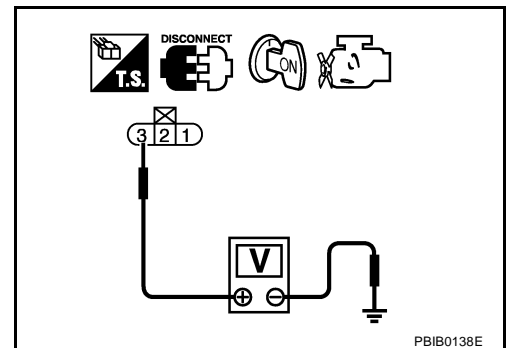

4. DETECT MALFUNCTIONING PART

Check the following.

- Harness connectors B201, M81
- Harness connectors M82, F102
- Harness for open or short between EVAP control system pressure sensor and ECM

>> Repair open circuit or short to ground or short to power in harness or connectors.

5. CHECK EVAP CONTROL SYSTEM PRESSURE SENSOR GROUND CIRCUIT FOR OPEN AND SHORT

1. Turn ignition switch OFF.
2. Disconnect ECM harness connector.
3. Check harness continuity between EVAP control system pressure sensor terminal 1 and ECM terminal 67.
Refer to Wiring Diagram.

Continuity should exist.

4. Also check harness for short to ground and short to power.

OK or NG

- OK >> GO TO 7.
NG >> GO TO 6.

6. DETECT MALFUNCTIONING PART

Check the following.

- Harness connectors B201, M81
- Harness connectors M82, F102
- Harness for open or short between EVAP control system pressure sensor and ECM

>> Repair open circuit or short to ground or short to power in harness or connectors.

7. CHECK EVAP CONTROL SYSTEM PRESSURE SENSOR INPUT SIGNAL CIRCUIT FOR OPEN AND SHORT

1. Check harness continuity between ECM terminal 32 and EVAP control system pressure sensor terminal 2.
Refer to Wiring Diagram.

Continuity should exist.

2. Also check harness for short to ground and short to power.

OK or NG

- OK >> GO TO 9.
NG >> GO TO 8.

8. DETECT MALFUNCTIONING PART

Check the following.

- Harness connectors B201, M81
- Harness connectors M82, F102
- Harness for open or short between EVAP control system pressure sensor and ECM

>> Repair open circuit or short to ground or short to power in harness or connectors.

9. CHECK EVAP CONTROL SYSTEM PRESSURE SENSOR

Refer to [EC-1013, "Component Inspection"](#) .

OK or NG

- OK >> GO TO 10.
NG >> Replace EVAP control system pressure sensor.

10. CHECK INTERMITTENT INCIDENT

Refer to [EC-784, "TROUBLE DIAGNOSIS FOR INTERMITTENT INCIDENT"](#) .

>> INSPECTION END

Component Inspection EVAP CONTROL SYSTEM PRESSURE SENSOR

ABS00C6G

1. Remove EVAP control system pressure sensor with its harness connector connected from EVAP canister.
Always replace O-ring with a new one.
2. Install a vacuum pump to EVAP control system pressure sensor.
3. Turn ignition switch ON and check output voltage between ECM terminal 32 and ground under the following conditions.

Applied vacuum kPa (mmHg, inHg)	Voltage V
Not applied	1.8 - 4.8
-26.7 (-200, -7.87)	2.1 to 2.5V lower than above value

CAUTION:

- Always calibrate the vacuum pump gauge when using it.
 - Do not apply below -93.3 kPa (-700 mmHg, -27.56 inHg) or pressure over 101.3 kPa (760 mmHg, 29.92 inHg).
4. If NG, replace EVAP control system pressure sensor.

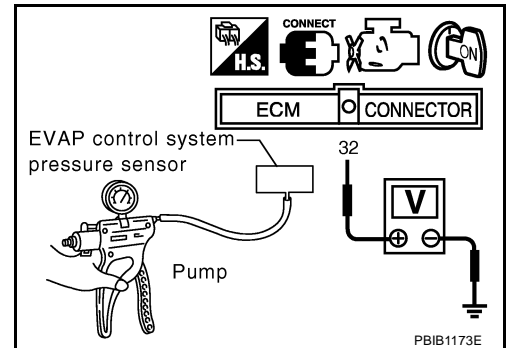

A
EC
C
D
E
F
G
H
I
J
K
L
M

DTC P0453 EVAP CONTROL SYSTEM PRESSURE SENSOR

[VK45DE]

DTC P0453 EVAP CONTROL SYSTEM PRESSURE SENSOR

PFP:25085

Component Description

ABS00C6H

The EVAP control system pressure sensor detects pressure in the purge line. The sensor output voltage to the ECM increases as pressure increases.

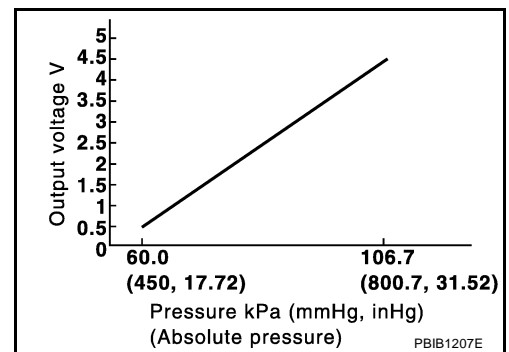
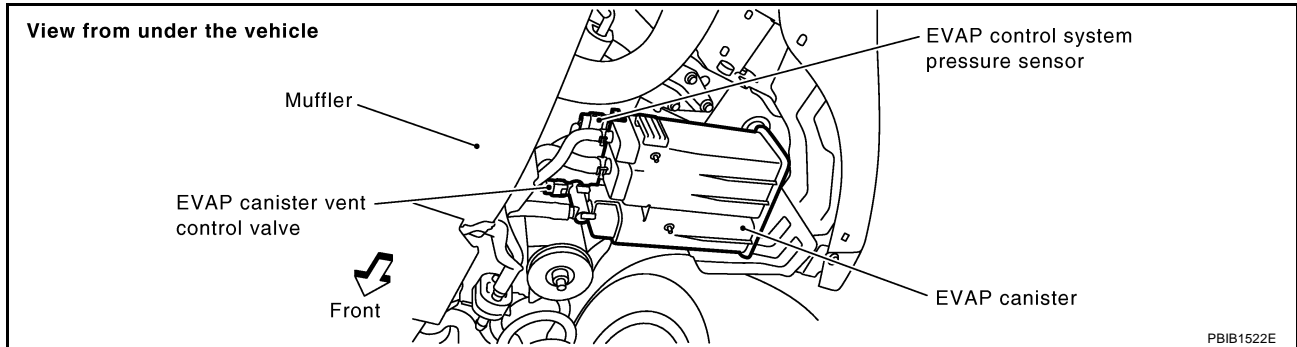

CONSULT-II Reference Value in Data Monitor Mode

ABS00C6I

Specification data are reference values.

MONITOR ITEM	CONDITION	SPECIFICATION
EVAP SYS PRES	● Ignition switch: ON	Approx. 1.8 - 4.8V

On Board Diagnosis Logic

ABS00C6J

NOTE:

If DTC P0453 is displayed with DTC P1229, first perform the trouble diagnosis for DTC P1229. Refer to [EC-1156](#).

DTC No.	Trouble diagnosis name	DTC detecting condition	Possible cause
P0453 0453	EVAP control system pressure sensor high input	An excessively high voltage from the sensor is sent to ECM.	<ul style="list-style-type: none"> ● Harness or connectors (The sensor circuit is open or shorted.) ● EVAP control system pressure sensor ● EVAP canister vent control valve ● EVAP canister ● Rubber hose from EVAP canister vent control valve to vehicle frame

DTC Confirmation Procedure

NOTE:

If DTC Confirmation Procedure has been previously conducted, always turn ignition switch OFF and wait at least 10 seconds before conducting the next test.

TESTING CONDITION:

Always perform test at a temperature of 5°C (41°F) or more.

WITH CONSULT-II

1. Start engine and warm it up to normal operating temperature.
2. Turn ignition switch OFF and wait at least 10 seconds.
3. Turn ignition switch ON.
4. Select "DATA MONITOR" mode with CONSULT-II.
5. Make sure that "FUEL T/TEMP SE" is more than 0°C (32°F).
6. Wait at least 10 seconds.
7. If 1st trip DTC is detected, go to [EC-1017, "Diagnostic Procedure"](#).

DATA MONITOR	
MONITOR	NO DTC
ENG SPEED	XXX rpm
COOLAN TEMP/S	XXX °C
FUEL T/TMP SE	XXX °C

SEF194Y

WITH GST

1. Start engine and warm it up to normal operating temperature.
2. Check that voltage between ECM terminal 107 (Fuel tank temperature sensor signal) and ground is less than 4.2V.
3. Turn ignition switch OFF and wait at least 10 seconds.
4. Wait at least 10 seconds.
5. Select MODE 7 with GST.
If 1st trip DTC is detected, go to [EC-1017, "Diagnostic Procedure"](#).

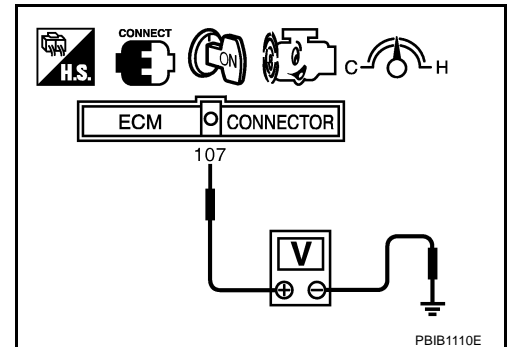

DTC P0453 EVAP CONTROL SYSTEM PRESSURE SENSOR

[VK45DE]

Wiring Diagram

ABS00C6L

EC-PRE/SE-01

: DETECTABLE LINE FOR DTC
 : NON-DETECTABLE LINE FOR DTC

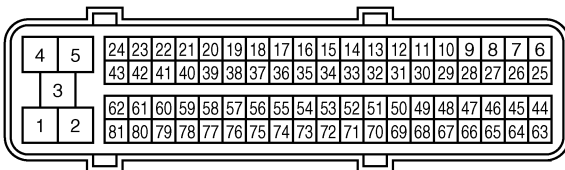
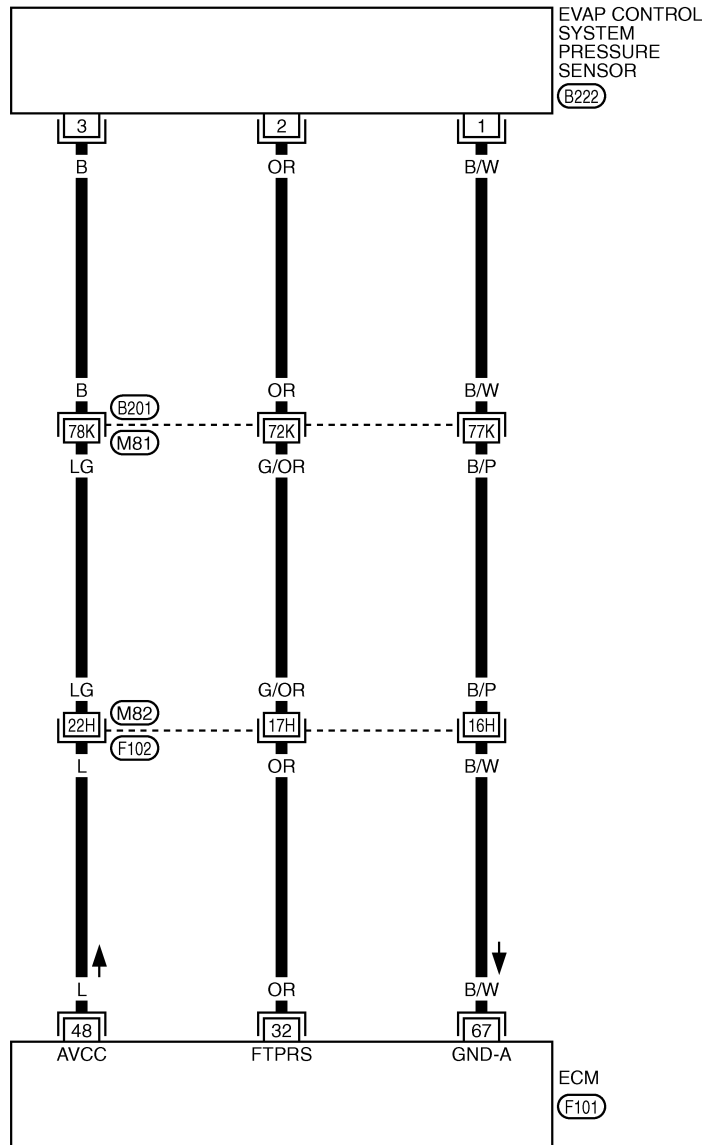

F101
B



3 2 1 B222
GY

REFER TO THE FOLLOWING.

(F102), (B201) -SUPER MULTIPLE JUNCTION (SMJ)

TBWH0115E

DTC P0453 EVAP CONTROL SYSTEM PRESSURE SENSOR

[VK45DE]

Specification data are reference values and are measured between each terminal and ground.

CAUTION:

Do not use ECM ground terminals when measuring input/output voltage. Doing so may result in damage to the ECM's transistor. Use a ground other than ECM terminals, such as the ground.

TER-MINAL NO.	WIRE COLOR	ITEM	CONDITION	DATA (DC Voltage)
32	OR	EVAP control system pressure sensor	[Ignition switch: ON]	Approximately 1.8 - 4.8V
48	L	Sensor power supply (Mass air flow sensor / EVAP control system pressure sensor)	[Ignition switch: ON]	Approximately 5V
67	B/W	Sensor ground (Mass air flow sensor / IAT sensor / Power steering pressure sensor / EVAP control system pressure sensor / Refrigerant pressure sensor / ECT sensor)	[Engine is running] <ul style="list-style-type: none"> ● Warm-up condition ● Idle speed 	Approximately 0V

Diagnostic Procedure

ABS00C6M

1. CHECK GROUND CONNECTIONS

1. Turn ignition switch OFF.
2. Loosen and retighten three ground screws on the body. Refer to [EC-791, "Ground Inspection"](#).

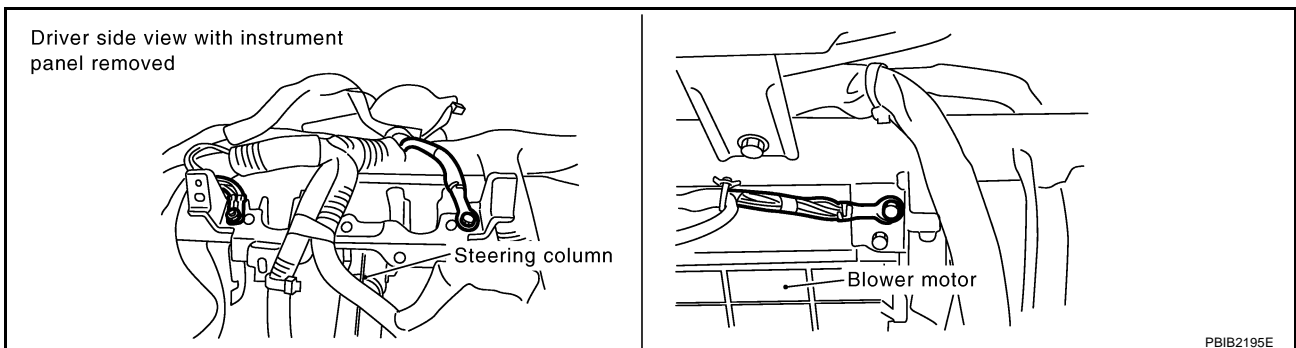

OK or NG

- OK >> GO TO 2.
- NG >> Repair or replace ground connections.

2. CHECK CONNECTOR

1. Disconnect EVAP control system pressure sensor harness connector.

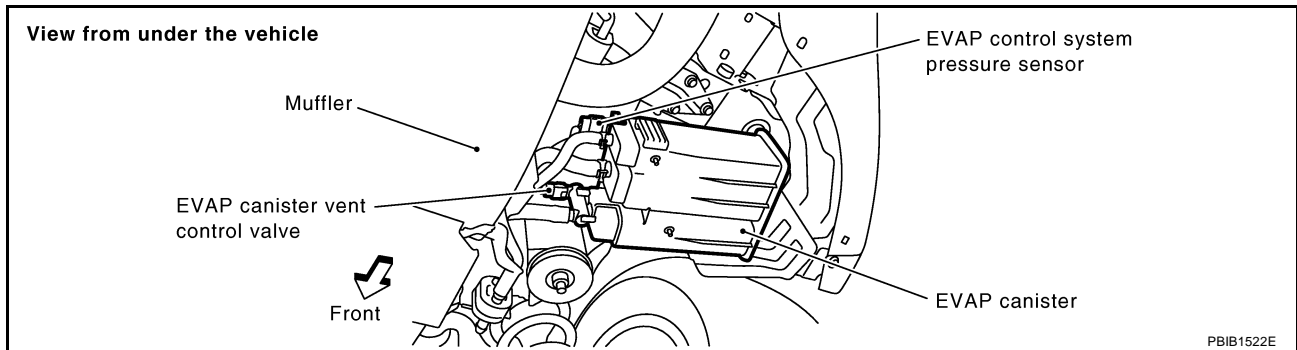

2. Check sensor harness connector for water.

Water should not exist.

OK or NG

- OK >> GO TO 3.
- NG >> Repair or replace harness connector.

3. CHECK EVAP CONTROL SYSTEM PRESSURE SENSOR POWER SUPPLY CIRCUIT

1. Turn ignition switch ON.
2. Check voltage between EVAP control system pressure sensor terminal 3 and ground with CONSULT-II or tester.

Voltage: Approximately 5V

OK or NG

- OK >> GO TO 5.
- NG >> GO TO 4.

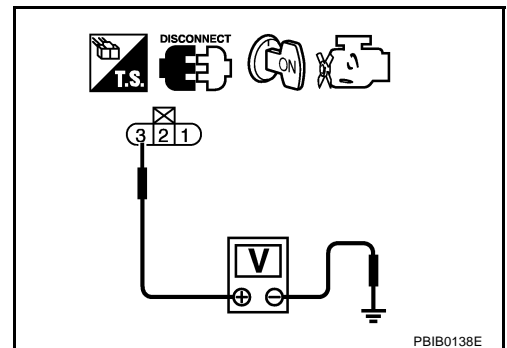

4. DETECT MALFUNCTIONING PART

Check the following.

- Harness connectors B201, M81
- Harness connectors M82, F102
- Harness for open or short between EVAP control system pressure sensor and ECM

>> Repair open circuit or short to ground or short to power in harness or connectors.

5. CHECK EVAP CONTROL SYSTEM PRESSURE SENSOR GROUND CIRCUIT FOR OPEN AND SHORT

1. Turn ignition switch OFF.
2. Disconnect ECM harness connector.
3. Check harness continuity between EVAP control system pressure sensor terminal 1 and ECM terminal 67.
Refer to Wiring Diagram.

Continuity should exist.

4. Also check harness for short to ground and short to power.

OK or NG

- OK >> GO TO 7.
- NG >> GO TO 6.

6. DETECT MALFUNCTIONING PART

Check the following.

- Harness connectors B201, M81
- Harness connectors M82, F102
- Harness for open or short between EVAP control system pressure sensor and ECM

>> Repair open circuit or short to ground or short to power in harness or connectors.

7. CHECK EVAP CONTROL SYSTEM PRESSURE SENSOR INPUT SIGNAL CIRCUIT FOR OPEN AND SHORT

1. Check harness continuity between ECM terminal 32 and EVAP control system pressure sensor terminal 2.
Refer to Wiring Diagram.

Continuity should exist.

2. Also check harness for short to ground and short to power.

OK or NG

- OK >> GO TO 9.
- NG >> GO TO 8.

8. DETECT MALFUNCTIONING PART

Check the following.

- Harness connectors B201, M81
- Harness connectors M82, F102
- Harness for open or short between EVAP control system pressure sensor and ECM

>> Repair open circuit or short to ground or short to power in harness or connectors.

9. CHECK RUBBER TUBE

1. Disconnect rubber tube connected to EVAP canister vent control valve.
2. Check the rubber tube for clogging.

OK or NG

- OK >> GO TO 10.
- NG >> Clean the rubber tube using an air blower, repair or replace rubber tube.

10. CHECK EVAP CANISTER VENT CONTROL VALVE

Refer to [EC-1002, "Component Inspection"](#) .

OK or NG

- OK >> GO TO 11.
NG >> Replace EVAP canister vent control valve.

11. CHECK EVAP CONTROL SYSTEM PRESSURE SENSOR

Refer to [EC-1021, "Component Inspection"](#) .

OK or NG

- OK >> GO TO 12.
NG >> Replace EVAP control system pressure sensor.

12. CHECK IF EVAP CANISTER SATURATED WITH WATER

1. Remove EVAP canister with EVAP canister vent control valve and EVAP control system pressure sensor attached.
2. Check if water will drain from the EVAP canister.

Yes or No

- Yes >> GO TO 13.
No >> GO TO 15.

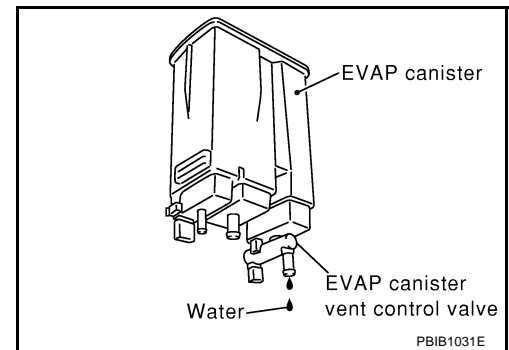

13. CHECK EVAP CANISTER

Weigh the EVAP canister with the EVAP canister vent control valve and EVAP control system pressure sensor attached.

The weight should be less than 2.1 kg (4.6 lb).

OK or NG

- OK >> GO TO 15.
NG >> GO TO 14.

14. DETECT MALFUNCTIONING PART

Check the following.

- EVAP canister for damage
- EVAP hose between EVAP canister and vehicle frame for clogging or poor connection

>> Repair hose or replace EVAP canister.

15. CHECK INTERMITTENT INCIDENT

Refer to [EC-784, "TROUBLE DIAGNOSIS FOR INTERMITTENT INCIDENT"](#) .

>> INSPECTION END

DTC P0453 EVAP CONTROL SYSTEM PRESSURE SENSOR

[VK45DE]

ABS00C6N

Component Inspection

EVAP CONTROL SYSTEM PRESSURE SENSOR

1. Remove EVAP control system pressure sensor with its harness connector connected from EVAP canister.
Always replace O-ring with a new one.
2. Install a vacuum pump to EVAP control system pressure sensor.
3. Turn ignition switch ON and check output voltage between ECM terminal 32 and ground under the following conditions.

Applied vacuum kPa (mmHg, inHg)	Voltage V
Not applied	1.8 - 4.8
-26.7 (-200, -7.87)	2.1 to 2.5V lower than above value

CAUTION:

- Always calibrate the vacuum pump gauge when using it.
 - Do not apply below -93.3 kPa (-700 mmHg, -27.56 inHg) or pressure over 101.3 kPa (760 mmHg, 29.92 inHg).
4. If NG, replace EVAP control system pressure sensor.

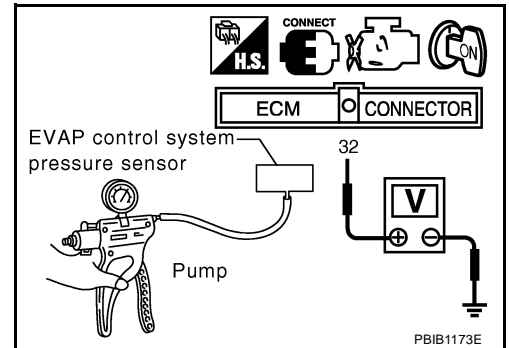

A
EC
C
D
E
F
G
H
I
J
K
L
M

DTC P0455 EVAP CONTROL SYSTEM

PFP:14950

On Board Diagnosis Logic

ABS00C60

This diagnosis detects a very large leak (fuel filler cap fell off etc.) in EVAP system between the fuel tank and EVAP canister purge volume control solenoid valve.

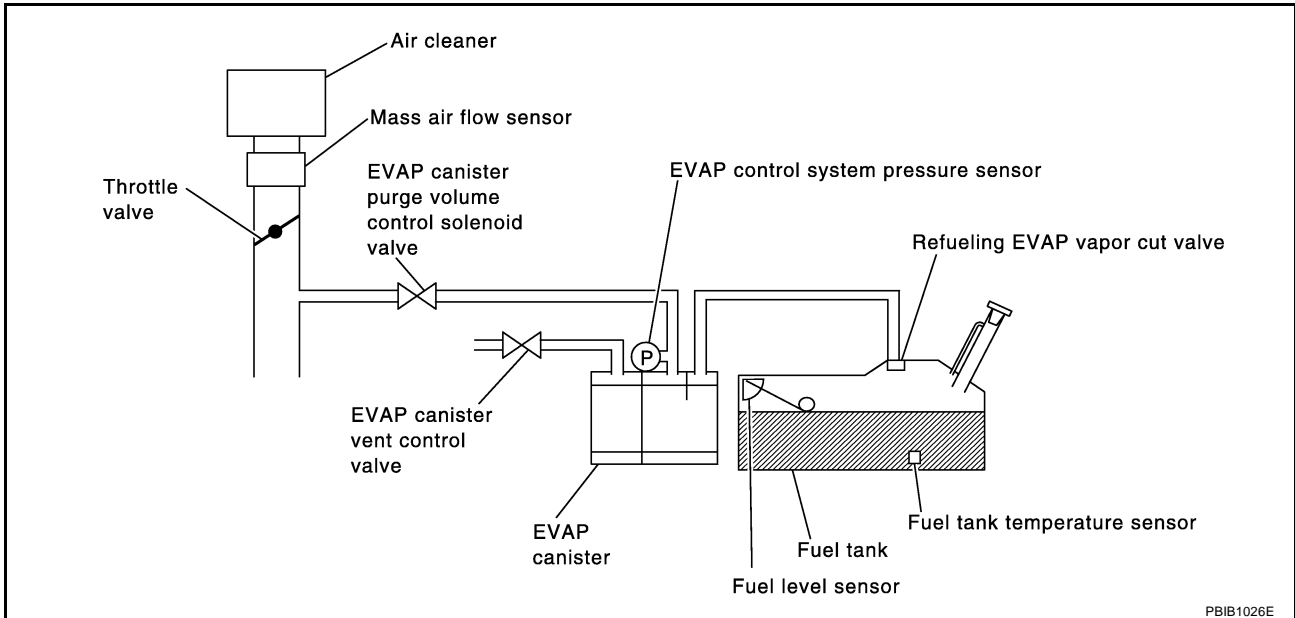

DTC No.	Trouble diagnosis name	DTC detecting condition	Possible cause
P0455 0455	EVAP control system gross leak detected	EVAP control system has a very large leak such as fuel filler cap fell off, EVAP control system does not operate properly.	<ul style="list-style-type: none"> ● Fuel filler cap remains open or fails to close. ● Incorrect fuel tank vacuum relief valve ● Incorrect fuel filler cap used ● Foreign matter caught in fuel filler cap. ● Leak is in line between intake manifold and EVAP canister purge volume control solenoid valve. ● Foreign matter caught in EVAP canister vent control valve. ● EVAP canister or fuel tank leaks ● EVAP purge line (pipe and rubber tube) leaks ● EVAP purge line rubber tube bent. ● Loose or disconnected rubber tube ● EVAP canister vent control valve and the circuit ● EVAP canister purge volume control solenoid valve and the circuit ● Fuel tank temperature sensor ● O-ring of EVAP canister vent control valve is missing or damaged. ● EVAP control system pressure sensor ● Refueling EVAP vapor cut valve ● ORVR system leaks

CAUTION:

- Use only a genuine NISSAN fuel filler cap as a replacement. If an incorrect fuel filler cap is used, the MIL may come on.
- If the fuel filler cap is not tightened properly, the MIL may come on.

- Use only a genuine NISSAN rubber tube as a replacement.

DTC Confirmation Procedure

ABS00C6P

CAUTION:

Never remove fuel filler cap during the DTC Confirmation Procedure.

NOTE:

- Make sure that EVAP hoses are connected to EVAP canister purge volume control solenoid valve properly.
- If DTC Confirmation Procedure has been previously conducted, always turn ignition switch OFF and wait at least 10 seconds before conducting the next test.

TESTING CONDITION:

- Perform "DTC WORK SUPPORT" when the fuel level is between 1/4 and 3/4 full, and vehicle is placed on flat level surface.
- Open engine hood before conducting the following procedures.

WITH CONSULT-II

1. Tighten fuel filler cap securely until ratcheting sound is heard.
2. Turn ignition switch ON.
3. Turn ignition switch OFF and wait at least 10 seconds.
4. Turn ignition switch ON and select "DATA MONITOR" mode with CONSULT-II.
5. Make sure that the following conditions are met.
COOLAN TEMP/S: 0 - 70°C (32 - 158°F)
INT/A TEMP SE: 0 - 60°C (32 - 140°F)
6. Select "EVAP SML LEAK P0442/P1442" of "EVAPORATIVE SYSTEM" in "DTC WORK SUPPORT" mode with CONSULT-II.
 Follow the instruction displayed.

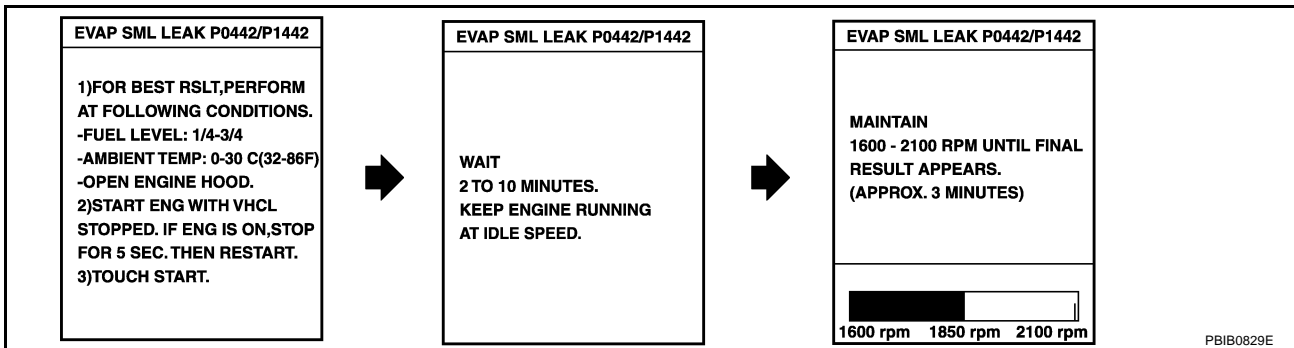

NOTE:

If the engine speed cannot be maintained within the range displayed on the CONSULT-II screen, go to [EC-733, "Basic Inspection"](#).

7. Make sure that "OK" is displayed.
 If "NG" is displayed, select "SELF-DIAG RESULTS" mode and make sure that "EVAP GROSS LEAK [P0455]" is displayed. If it is displayed, refer to [EC-1024, "Diagnostic Procedure"](#).
 If P0442 is displayed, perform Diagnostic Procedure for DTC P0442 [EC-983, "Diagnostic Procedure"](#).

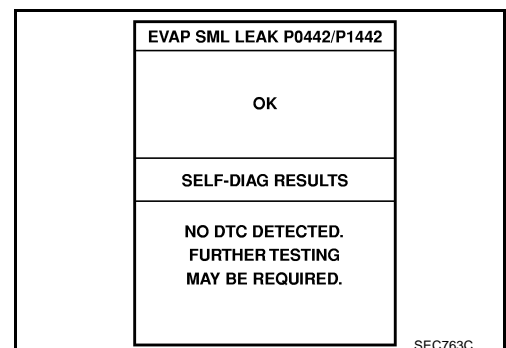

WITH GST**NOTE:**

Be sure to read the explanation of [EC-713, "Driving Pattern"](#) before driving vehicle.

1. Start engine.
2. Drive vehicle according to [EC-713, "Driving Pattern"](#) .
3. Stop vehicle.
4. Turn ignition switch OFF, wait at least 10 seconds and then turn ON.
5. Select MODE 7 with GST.
 - If P0455 is displayed on the screen, go to [EC-1024, "Diagnostic Procedure"](#) .
 - If P0442 is displayed on the screen, go to [EC-983, "Diagnostic Procedure"](#) .
 - If P0441 is displayed on the screen, go to [EC-978, "Diagnostic Procedure"](#) .

Diagnostic Procedure

ABS00C6Q

1. CHECK FUEL FILLER CAP DESIGN

1. Turn ignition switch OFF.
2. Check for genuine NISSAN fuel filler cap design.

OK or NG

- OK >> GO TO 2.
 NG >> Replace with genuine NISSAN fuel filler cap.

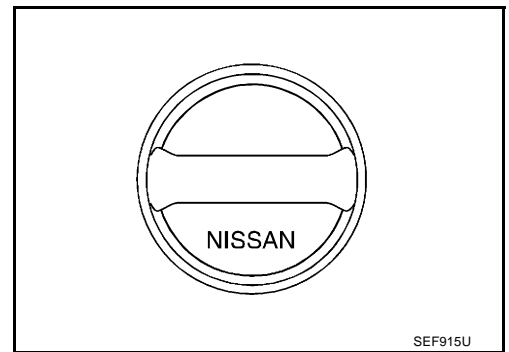
**2. CHECK FUEL FILLER CAP INSTALLATION**

Check that the cap is tightened properly by rotating the cap clockwise.

OK or NG

- OK >> GO TO 3.
 NG >> 1. Open fuel filler cap, then clean cap and fuel filler neck threads using air blower.
 2. Retighten until ratcheting sound is heard.

3. CHECK FUEL FILLER CAP FUNCTION

Check for air releasing sound while opening the fuel filler cap.

OK or NG

- OK >> GO TO 5.
 NG >> GO TO 4.

4. CHECK FUEL TANK VACUUM RELIEF VALVE

Refer to [EC-1323, "FUEL TANK VACUUM RELIEF VALVE \(BUILT INTO FUEL FULLER CAP\)"](#) .

OK or NG

- OK >> GO TO 5.
 NG >> Replace fuel filler cap with a genuine one.

5. CHECK EVAP PURGE LINE

Check EVAP purge line (pipe, rubber tube, fuel tank and EVAP canister) for cracks, improper connection or disconnection.

Refer to [EC-1321, "EVAPORATIVE EMISSION LINE DRAWING"](#) .

OK or NG

OK >> GO TO 6.

NG >> Repair or reconnect the hose.

6. CLEAN EVAP PURGE LINE

Clean EVAP purge line (pipe and rubber tube) using air blower.

>> GO TO 7.

7. CHECK EVAP CANISTER VENT CONTROL VALVE

Check the following.

- EVAP canister vent control valve is installed properly.
Refer to [EC-1324, "Removal and Installation"](#) .
- EVAP canister vent control valve.
Refer to [EC-1002, "Component Inspection"](#) .

OK or NG

OK >> GO TO 8.

NG >> Repair or replace EVAP canister vent control valve and O-ring.

8. INSTALL THE PRESSURE PUMP

To locate the EVAP leak, install EVAP service port adapter and pressure pump to EVAP service port securely.

NOTE:

Improper installation of the EVAP service port adapter to the EVAP service port may cause leaking.

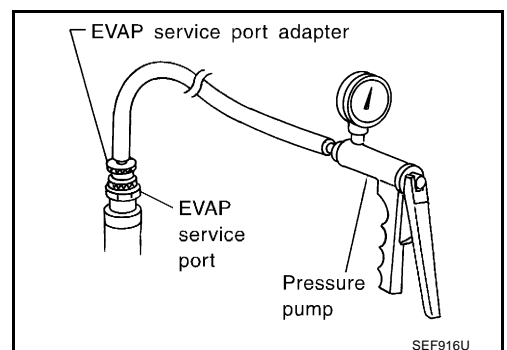
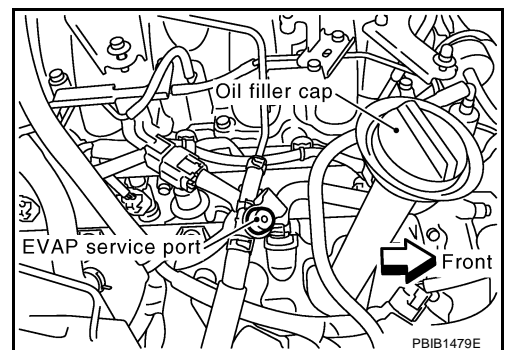

With CONSULT-II>>GO TO 9.

Without CONSULT-II>>GO TO 10.

9. CHECK FOR EVAP LEAK

With CONSULT-II

1. Turn ignition switch ON.
2. Select "EVAP SYSTEM CLOSE" of "WORK SUPPORT" mode with CONSULT-II.
3. Touch "START" and apply pressure into the EVAP line until the pressure indicator reaches the middle of the bar graph.

NOTE:

- Do not use compressed air or a high pressure pump.
- Do not exceed 4.12 kPa (0.042 kg/cm² , 0.6 psi) of pressure in the system.

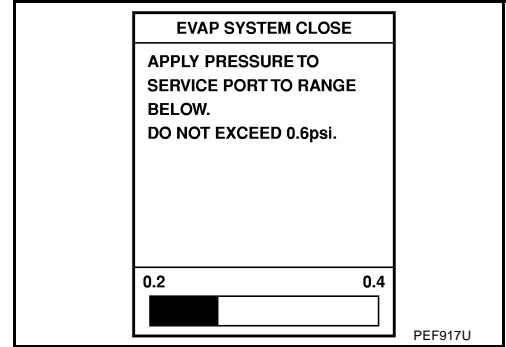

4. Using EVAP leak detector, locate the EVAP leak. For the leak detector, refer to the instruction manual for more details. Refer to [EC-1321, "EVAPORATIVE EMISSION LINE DRAWING"](#).

OK or NG

- OK >> GO TO 11.
 NG >> Repair or replace.

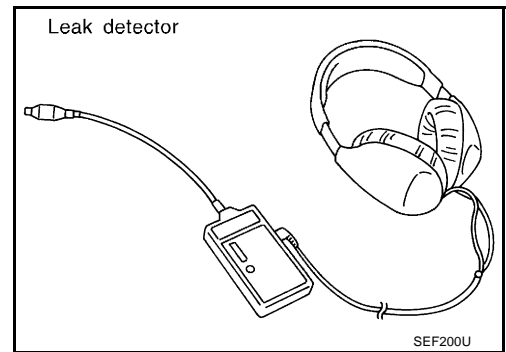

10. CHECK FOR EVAP LEAK

⊗ Without CONSULT-II

1. Turn ignition switch OFF.
2. Apply 12 volts DC to EVAP canister vent control valve. The valve will close. (Continue to apply 12 volts until the end of test.)

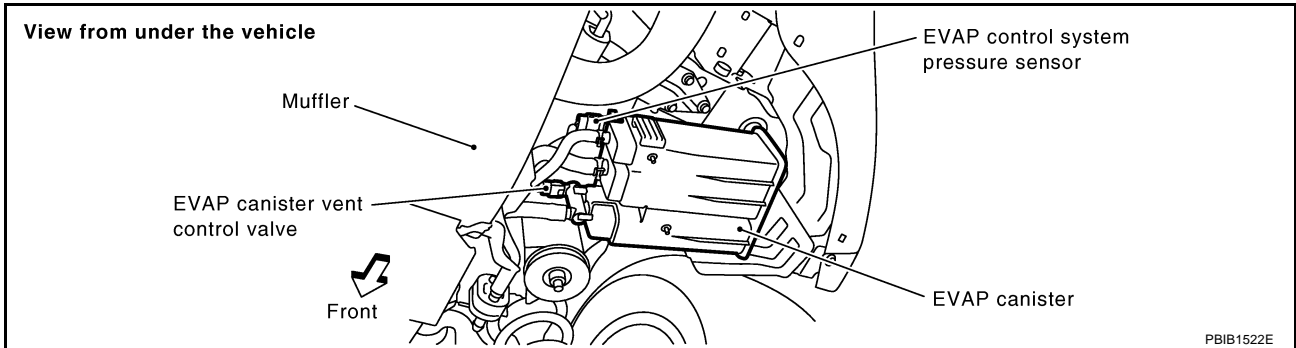

3. Pressurize the EVAP line using pressure pump with 1.3 to 2.7 kPa (10 to 20 mmHg, 0.39 to 0.79 inHg), then remove pump and EVAP service port adapter.

NOTE:

- Do not use compressed air or a high pressure pump.
- Do not exceed 4.12 kPa (0.042 kg/cm², 0.6 psi) of pressure in the system.

4. Using EVAP leak detector, locate the EVAP leak. For the leak detector, refer to the instruction manual for more details. Refer to [EC-1321, "EVAPORATIVE EMISSION LINE DRAWING"](#).

OK or NG

- OK >> GO TO 12.
 NG >> Repair or replace.

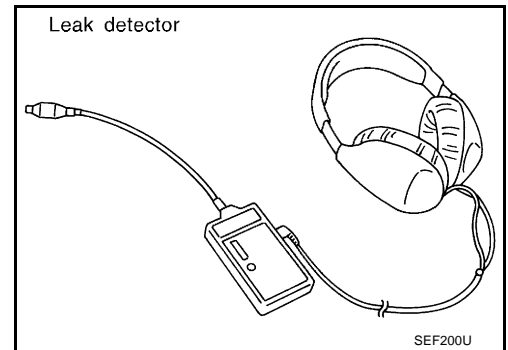

11. CHECK EVAP CANISTER PURGE VOLUME CONTROL SOLENOID VALVE OPERATION

Ⓟ With CONSULT-II

1. Disconnect vacuum hose to EVAP canister purge volume control solenoid valve at EVAP service port.
2. Start engine.
3. Perform "PURG VOL CONT/V" in "ACTIVE TEST" mode.
4. Touch "Qu" on CONSULT-II screen to increase "PURG VOL CONT/V" opening to 100%.
5. Check vacuum hose for vacuum when revving engine up to 2,000 rpm.

OK or NG

- OK >> GO TO 14.
 NG >> GO TO 13.

ACTIVE TEST	
PURG VOL CONT/V	XXX %
MONITOR	
ENG SPEED	XXX rpm
A/F ALPHA-B1	XX %
HO2S1 MNTR (B1)	LEAN

PBIB0828E

12. CHECK EVAP CANISTER PURGE VOLUME CONTROL SOLENOID VALVE OPERATION

⊗ Without CONSULT-II

1. Start engine and warm it up to normal operating temperature.
2. Stop engine.
3. Disconnect vacuum hose to EVAP canister purge volume control solenoid valve at EVAP service port.
4. Start engine and let it idle for at least 80 seconds.
5. Check vacuum hose for vacuum when revving engine up to 2,000 rpm.

Vacuum should exist.

OK or NG

- OK >> GO TO 15.
 NG >> GO TO 13.

13. CHECK VACUUM HOSE

Check vacuum hoses for clogging or disconnection. Refer to [EC-677, "Vacuum Hose Drawing"](#) .

OK or NG

- OK (With CONSULT-II)>>GO TO 14.
 OK (Without CONSULT-II)>>GO TO 15.
 NG >> Repair or reconnect the hose.

14. CHECK EVAP CANISTER PURGE VOLUME CONTROL SOLENOID VALVE

Ⓜ With CONSULT-II

1. Start engine.
2. Perform "PURG VOL CONT/V" in "ACTIVE TEST" mode with CONSULT-II. Check that engine speed varies according to the valve opening.

OK or NG

- OK >> GO TO 16.
 NG >> GO TO 15.

ACTIVE TEST	
PURG VOL CONT/V	XXX %
MONITOR	
ENG SPEED	XXX rpm
A/F ALPHA-B1	XX %
HO2S1 MNTR (B1)	LEAN

PBIB0628E

15. CHECK EVAP CANISTER PURGE VOLUME CONTROL SOLENOID VALVE

Refer to [EC-995, "Component Inspection"](#) .

OK or NG

- OK >> GO TO 16.
 NG >> Replace EVAP canister purge volume control solenoid valve.

16. CHECK FUEL TANK TEMPERATURE SENSOR

Refer to [EC-936, "Component Inspection"](#) .

OK or NG

- OK >> GO TO 17.
 NG >> Replace fuel level sensor unit.

17. CHECK EVAP CONTROL SYSTEM PRESSURE SENSOR

Refer to [EC-1013, "Component Inspection"](#) .

OK or NG

- OK >> GO TO 18.
- NG >> Replace EVAP control system pressure sensor.

18. CHECK EVAP/ORVR LINE

Check EVAP/ORVR line between EVAP canister and fuel tank for clogging, kink, looseness and improper connection. For location, refer to [EC-1327, "ON BOARD REFUELING VAPOR RECOVERY \(ORVR\)"](#) .

OK or NG

- OK >> GO TO 19.
- NG >> Repair or replace hoses and tubes.

19. CHECK RECIRCULATION LINE

Check recirculation line between filler neck tube and fuel tank for clogging, kink, cracks, looseness and improper connection.

OK or NG

- OK >> GO TO 20.
- NG >> Repair or replace hose, tube or filler neck tube.

20. CHECK REFUELING EVAP VAPOR CUT VALVE

Refer to [EC-1330, "REFUELING EVAP VAPOR CUT VALVE"](#) .

OK or NG

- OK >> GO TO 21.
- NG >> Replace refueling EVAP vapor cut valve with fuel tank.

21. CHECK INTERMITTENT INCIDENT

Refer to [EC-784, "TROUBLE DIAGNOSIS FOR INTERMITTENT INCIDENT"](#) .

>> **INSPECTION END**

A

EC

C

D

E

F

G

H

I

J

K

L

M

DTC P0456 EVAP CONTROL SYSTEM

PFP:14950

On Board Diagnosis Logic

ABS00C6R

This diagnosis detects very small leaks in the EVAP line between fuel tank and EVAP canister purge volume control solenoid valve, using the intake manifold vacuum in the same way as conventional EVAP small leak diagnosis.

If ECM judges a leak which corresponds to a very small leak, the very small leak P0456 will be detected.

If ECM judges a leak equivalent to a small leak, EVAP small leak P0442 will be detected.

If ECM judges there are no leaks, the diagnosis will be OK.

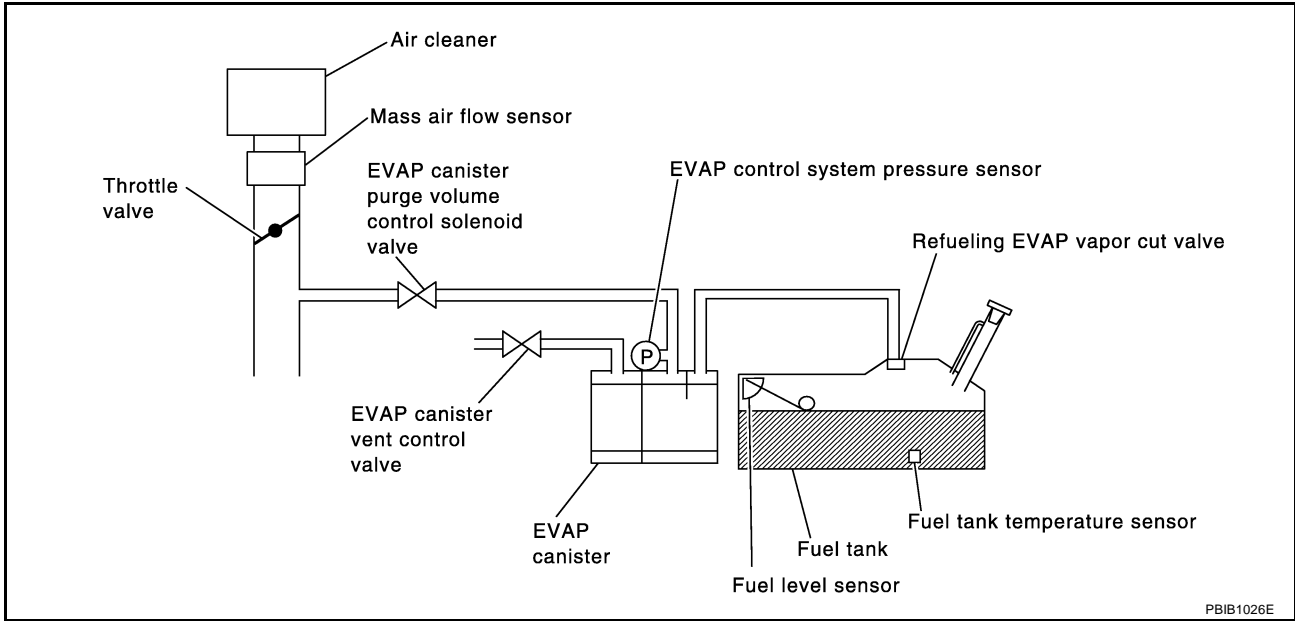

DTC No.	Trouble diagnosis name	DTC detecting condition	Possible cause
P0456 0456	Evaporative emission control system very small leak (negative pressure check)	<ul style="list-style-type: none"> ● EVAP system has a very small leak. ● EVAP system does not operate properly. 	<ul style="list-style-type: none"> ● Incorrect fuel tank vacuum relief valve ● Incorrect fuel filler cap used ● Fuel filler cap remains open or fails to close. ● Foreign matter caught in fuel filler cap. ● Leak is in line between intake manifold and EVAP canister purge volume control solenoid valve. ● Foreign matter caught in EVAP canister vent control valve. ● EVAP canister or fuel tank leaks ● EVAP purge line (pipe and rubber tube) leaks ● EVAP purge line rubber tube bent ● Loose or disconnected rubber tube ● EVAP canister vent control valve and the circuit ● EVAP canister purge volume control solenoid valve and the circuit ● Fuel tank temperature sensor ● O-ring of EVAP canister vent control valve is missing or damaged ● EVAP canister is saturated with water ● EVAP control system pressure sensor ● Refueling EVAP vapor cut valve ● ORVR system leaks ● Fuel level sensor and the circuit ● Foreign matter caught in EVAP canister purge volume control solenoid valve

CAUTION:

- Use only a genuine NISSAN fuel filler cap as a replacement. If an incorrect fuel filler cap is used, the MIL may come on. A
- If the fuel filler cap is not tightened properly, the MIL may come on.
- Use only a genuine NISSAN rubber tube as a replacement. EC

DTC Confirmation Procedure

ABS00C6S

NOTE:

- If DTC P0456 is displayed with P0442, first perform trouble diagnosis for DTC P0456. C
- After repair, make sure that the hoses and clips are installed properly.
- If DTC Confirmation Procedure has been previously conducted, always turn ignition switch OFF and wait at least 10 seconds before conducting the next test. D

TESTING CONDITION:

- Open engine hood before conducting following procedure. E
- If any of following conditions are met just before the DTC confirmation procedure, leave the vehicle for more than 1 hour. F
- Fuel filler cap is removed.
- Fuel is refilled or drained.
- EVAP component parts is/are removed.
- Before performing the following procedure, confirm that battery voltage is more than 11V at idle. G

H

I

J

K

L

M

WITH CONSULT-II

1. Turn ignition switch ON and select "DATA MONITOR" mode with CONSULT-II.
2. Make sure the following conditions are met.
FUEL LEVEL SE: 0.25 - 1.4V
COOLANT TEMP/S: 0 - 32°C (32 - 90°F)
FUEL T/TMP SE: 0 - 35°C (32 - 95°F)
INT A/TEMP SE: More than 0°C (32°F)
 If NG, turn ignition switch OFF and leave the vehicle in a cool place (soak the vehicle) or refilling/draining fuel until the output voltage condition of the "FUEL LEVEL SE" meets within the range above and leave the vehicle for more than 1 hour. Then start from step 1).
3. Turn ignition switch OFF and wait at least 10 seconds.
4. Turn ignition switch ON.
5. Select "EVAP V/S LEAK P0456/P1456" of "EVAPORATIVE SYSTEM" in "DTC WORK SUPPORT" mode with CONSULT-II.
 Follow the instruction displayed.

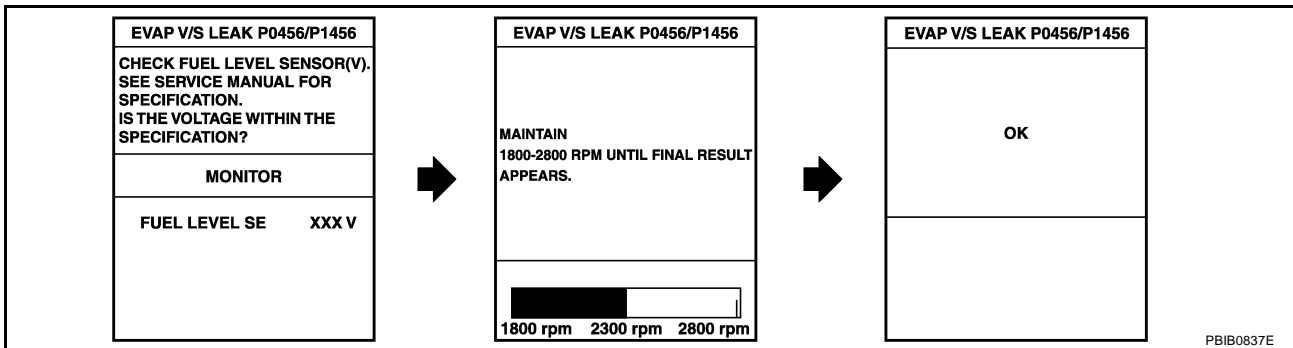

6. Make sure that "OK" is displayed.
 If "NG" is displayed, refer to [EC-1033, "Diagnostic Procedure"](#).

NOTE:

- If the engine speed cannot be maintained within the range displayed on CONSULT-II screen, go to [EC-733, "Basic Inspection"](#).
- Make sure that EVAP hoses are connected to EVAP canister purge volume control solenoid valve properly.

Overall Function Check

ABS00C6T

WITH GST

Use this procedure to check the overall function of the EVAP very small leak function. During this check, a 1st trip DTC might not be confirmed.

CAUTION:

- Do not use compressed air, doing so may damage the EVAP system.
- Do not start engine.
- Do not exceeded 4.12 kPa (0.042 kg/cm², 0.6 psi).

1. Attach the EVAP service port adapter securely to the EVAP service port.

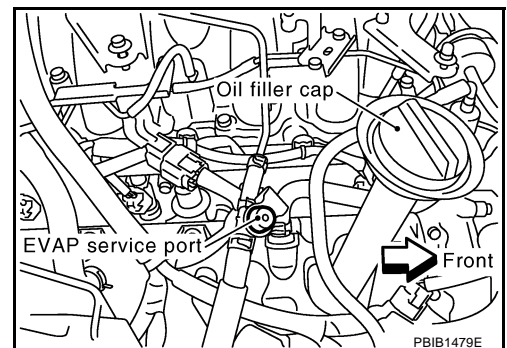

DTC P0456 EVAP CONTROL SYSTEM

[VK45DE]

2. Set the pressure pump and a hose.
3. Also set a vacuum gauge via 3-way connector and a hose.
4. Turn ignition switch ON.
5. Connect GST and select MODE 8.
6. Using MODE 8 control the EVAP canister vent control valve (close).
7. Apply pressure and make sure the following conditions are satisfied.

Pressure to be applied: 2.7 kPa (20 mmHg, 0.79 inHg)

Time to be waited after the pressure drawn in to the EVAP system and the pressure to be dropped: 60 seconds and the pressure should not be dropped more than 0.4 kPa (3 mmHg, 0.12 inHg).

If NG, go to [EC-1033, "Diagnostic Procedure"](#).

If OK, go to next step.

8. Disconnect GST.
9. Start engine and warm it up to normal operating temperature.
10. Turn ignition switch OFF and wait at least 10 seconds.
11. Restart engine and let it idle for 90 seconds.
12. Keep engine speed at 2,000 rpm for 30 seconds.
13. Turn ignition switch OFF.

NOTE:

For more information, refer to GST instruction manual.

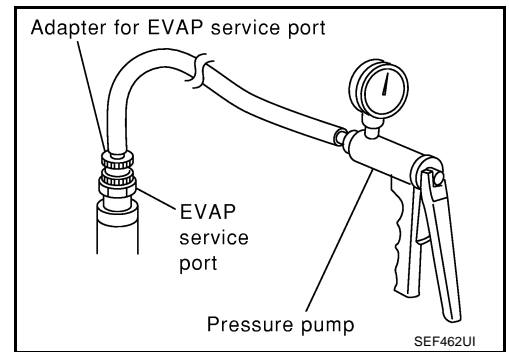

Diagnostic Procedure

1. CHECK FUEL FILLER CAP DESIGN

1. Turn ignition switch OFF.
2. Check for genuine NISSAN fuel filler cap design.

OK or NG

OK >> GO TO 2.

NG >> Replace with genuine NISSAN fuel filler cap.

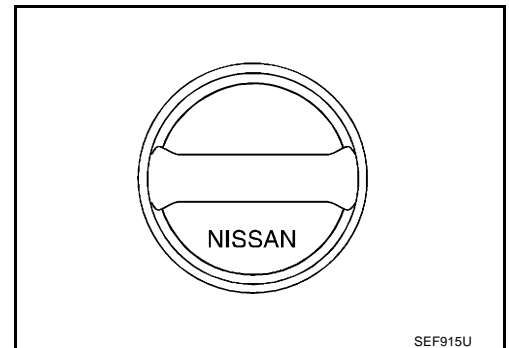

2. CHECK FUEL FILLER CAP INSTALLATION

Check that the cap is tightened properly by rotating the cap clockwise.

OK or NG

OK >> GO TO 3.

NG >> 1. Open fuel filler cap, then clean cap and fuel filler neck threads using air blower.

2. Retighten until ratcheting sound is heard.

3. CHECK FUEL FILLER CAP FUNCTION

Check for air releasing sound while opening the fuel filler cap.

OK or NG

OK >> GO TO 5.

NG >> GO TO 4.

4. CHECK FUEL TANK VACUUM RELIEF VALVE

Refer to [EC-1323, "FUEL TANK VACUUM RELIEF VALVE \(BUILT INTO FUEL FULLER CAP\)"](#) .

OK or NG

OK >> GO TO 5.

NG >> Replace fuel filler cap with a genuine one.

5. INSTALL THE PRESSURE PUMP

To locate the EVAP leak, install EVAP service port adapter and pressure pump to EVAP service port securely. For the location of EVAP service port, refer to [EC-1321, "EVAPORATIVE EMISSION LINE DRAWING"](#) .

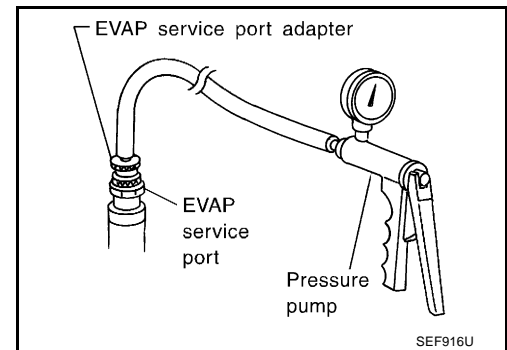
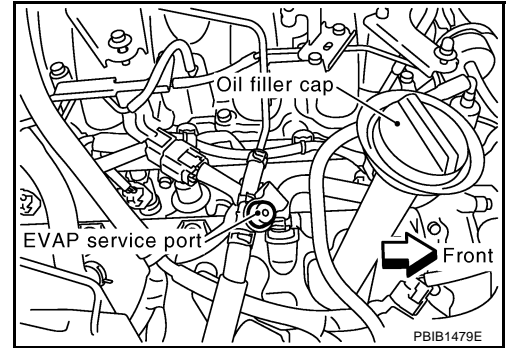

NOTE:

Improper installation of the EVAP service port adapter to the EVAP service port may cause leaking.

With CONSULT-II>>GO TO 6.

Without CONSULT-II>>GO TO 7.

6. CHECK FOR EVAP LEAK

With CONSULT-II

1. Turn ignition switch ON.
2. Select "EVAP SYSTEM CLOSE" of "WORK SUPPORT" mode with CONSULT-II.
3. Touch "START" and apply pressure into the EVAP line until the pressure indicator reaches the middle of the bar graph.

NOTE:

- Do not use compressed air or a high pressure pump.
- Do not exceed 4.12 kPa (0.042 kg/cm² , 0.6 psi) of pressure in the system.

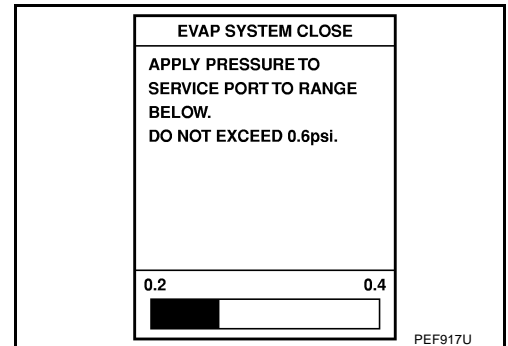

4. Using EVAP leak detector, locate the EVAP leak. For the leak detector, refer to the instruction manual for more details. Refer to [EC-1321, "EVAPORATIVE EMISSION LINE DRAWING"](#).

OK or NG

- OK >> GO TO 8.
 NG >> Repair or replace.

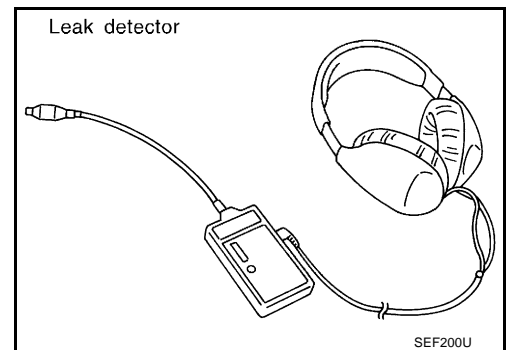

A
 EC
 C
 D
 E
 F
 G
 H
 I
 J
 K
 L
 M

7. CHECK FOR EVAP LEAK

⊗ **Without CONSULT-II**

1. Turn ignition switch OFF.
2. Apply 12 volts DC to EVAP canister vent control valve. The valve will close. (Continue to apply 12 volts until the end of test.)

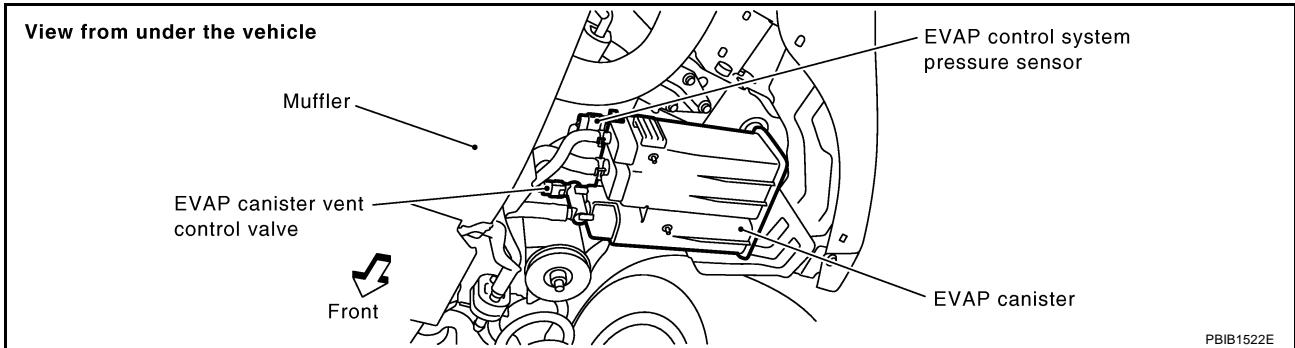

3. Pressurize the EVAP line using pressure pump with 1.3 to 2.7 kPa (10 to 20 mmHg, 0.39 to 0.79 inHg), then remove pump and EVAP service port adapter.

NOTE:

- Do not use compressed air or a high pressure pump.
- Do not exceed 4.12 kPa (0.042 kg/cm², 0.6 psi) of pressure in the system.

4. Using EVAP leak detector, locate the EVAP leak. For the leak detector, refer to the instruction manual for more details. Refer to [EC-1321, "EVAPORATIVE EMISSION LINE DRAWING"](#).

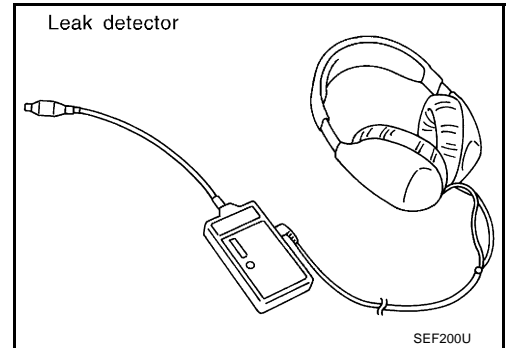

OK or NG

- OK >> GO TO 8.
 NG >> Repair or replace.

8. CHECK EVAP CANISTER VENT CONTROL VALVE

Check the following.

- EVAP canister vent control valve is installed properly. Refer to [EC-1324, "Removal and Installation"](#).
- EVAP canister vent control valve. Refer to [EC-1002, "Component Inspection"](#).

OK or NG

- OK >> GO TO 9.
 NG >> Repair or replace EVAP canister vent control valve and O-ring.

9. CHECK IF EVAP CANISTER SATURATED WITH WATER

1. Remove EVAP canister with EVAP canister vent control valve and EVAP control system pressure sensor attached.
2. Does water drain from the EVAP canister?

Yes or No

- Yes >> GO TO 10.
- No (With CONSULT-II)>>GO TO 12.
- No (Without CONSULT-II)>>GO TO 13.

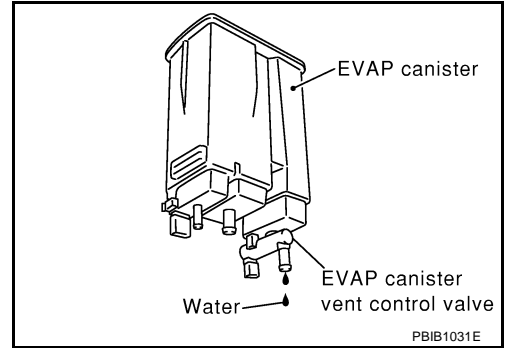

10. CHECK EVAP CANISTER

Weigh the EVAP canister with the EVAP canister vent control valve and EVAP control system pressure sensor attached.

The weight should be less than 2.1 kg (4.6 lb).

OK or NG

- OK (With CONSULT-II)>>GO TO 12.
- OK (Without CONSULT-II)>>GO TO 13.
- NG >> GO TO 11.

11. DETECT MALFUNCTIONING PART

Check the following.

- EVAP canister for damage
- EVAP hose between EVAP canister and vehicle frame for clogging or poor connection

>> Repair hose or replace EVAP canister.

12. CHECK EVAP CANISTER PURGE VOLUME CONTROL SOLENOID VALVE OPERATION

Ⓟ With CONSULT-II

1. Disconnect vacuum hose to EVAP canister purge volume control solenoid valve at EVAP service port.
2. Start engine.
3. Perform "PURG VOL CONT/V" in "ACTIVE TEST" mode.
4. Touch "Qu" on CONSULT-II screen to increase "PURG VOL CONT/V" opening to 100%.
5. Check vacuum hose for vacuum when revving engine up to 2,000 rpm.

OK or NG

- OK >> GO TO 15.
- NG >> GO TO 14.

ACTIVE TEST	
PURG VOL CONT/V	0 %
MONITOR	
ENG SPEED	XXX rpm
HO2S1 MNTR (B1)	LEAN
HO2S1 MNTR (B2)	LEAN
A/F ALPHA-B1	XXX %
A/F ALPHA-B2	XXX %

PBIB0147E

13. CHECK EVAP CANISTER PURGE VOLUME CONTROL SOLENOID VALVE OPERATION

⊗ Without CONSULT-II

1. Start engine and warm it up to normal operating temperature.
2. Stop engine.
3. Disconnect vacuum hose to EVAP canister purge volume control solenoid valve at EVAP service port.
4. Start engine and let it idle for at least 80 seconds.
5. Check vacuum hose for vacuum when revving engine up to 2,000 rpm.

Vacuum should exist.

OK or NG

- OK >> GO TO 16.
 NG >> GO TO 14.

14. CHECK VACUUM HOSE

Check vacuum hoses for clogging or disconnection. Refer to [EC-677, "Vacuum Hose Drawing"](#) .

OK or NG

- OK >> GO TO 15.
 NG >> Repair or reconnect the hose.

15. CHECK EVAP CANISTER PURGE VOLUME CONTROL SOLENOID VALVE

Refer to [EC-995, "Component Inspection"](#) .

OK or NG

- OK >> GO TO 16.
 NG >> Replace EVAP canister purge volume control solenoid valve.

16. CHECK FUEL TANK TEMPERATURE SENSOR

Refer to [EC-936, "Component Inspection"](#) .

OK or NG

- OK >> GO TO 17.
 NG >> Replace fuel level sensor unit.

17. CHECK EVAP CONTROL SYSTEM PRESSURE SENSOR

Refer to [EC-1013, "Component Inspection"](#) .

OK or NG

- OK >> GO TO 18.
 NG >> Replace EVAP control system pressure sensor.

18. CHECK EVAP PURGE LINE

Check EVAP purge line (pipe, rubber tube, fuel tank and EVAP canister) for cracks or improper connection. Refer to [EC-1321, "EVAPORATIVE EMISSION LINE DRAWING"](#) .

OK or NG

- OK >> GO TO 19.
 NG >> Repair or reconnect the hose.

19. CLEAN EVAP PURGE LINE

Clean EVAP purge line (pipe and rubber tube) using air blower.

>> GO TO 20.

20. CHECK EVAP/ORVR LINE

Check EVAP/ORVR line between EVAP canister and fuel tank for clogging, kink, looseness and improper connection. For location, refer to [EC-1327, "ON BOARD REFUELING VAPOR RECOVERY \(ORVR\)"](#) .

OK or NG

- OK >> GO TO 21.
- NG >> Repair or replace hoses and tubes.

21. CHECK RECIRCULATION LINE

Check recirculation line between filler neck tube and fuel tank for clogging, kink, cracks, looseness and improper connection.

OK or NG

- OK >> GO TO 22.
- NG >> Repair or replace hose, tube or filler neck tube.

22. CHECK REFUELING EVAP VAPOR CUT VALVE

Refer to [EC-1330, "Component Inspection"](#) .

OK or NG

- OK >> GO TO 23.
- NG >> Replace refueling EVAP vapor cut valve with fuel tank.

23. CHECK FUEL LEVEL SENSOR

Refer to [DI-25, "CHECK FUEL LEVEL SENSOR UNIT"](#) .

OK or NG

- OK >> GO TO 24.
- NG >> Replace fuel level sensor unit.

24. CHECK INTERMITTENT INCIDENT

Refer to [EC-784, "TROUBLE DIAGNOSIS FOR INTERMITTENT INCIDENT"](#) .

>> **INSPECTION END**

A

EC

C

D

E

F

G

H

I

J

K

L

M

DTC P0460 FUEL LEVEL SENSOR

PFP:25060

Component Description

ABS00C6V

The fuel level sensor is mounted in the fuel level sensor unit. The sensor detects a fuel level in the fuel tank and transmits a signal to the “unified meter and A/C amp.”. The “unified meter and A/C amp.” sends the fuel level sensor signal to the ECM through CAN communication line.

It consists of two parts, one is mechanical float and the other is variable resistor. Fuel level sensor output voltage changes depending on the movement of the fuel mechanical float.

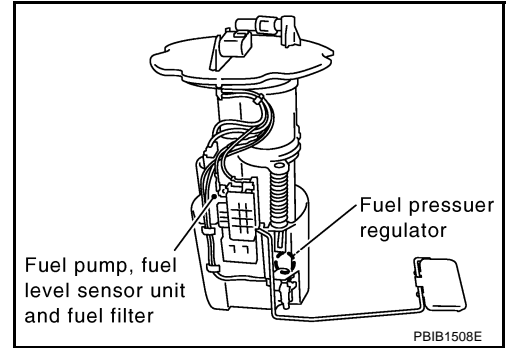

On Board Diagnosis Logic

ABS00C6W

NOTE:

If DTC P0460 is displayed with DTC U1000 or U1001, first perform the trouble diagnosis for DTC U1000, U1001. Refer to [EC-792](#).

When the vehicle is parked, naturally the fuel level in the fuel tank is stable. It means that output signal of the fuel level sensor does not change. If ECM senses sloshing signal from the sensor, fuel level sensor malfunction is detected.

DTC No.	Trouble diagnosis name	DTC detecting condition	Possible cause
P0460 0460	Fuel level sensor circuit noise	Even though the vehicle is parked, a signal being varied is sent from the fuel level sensor to ECM.	<ul style="list-style-type: none"> ● Harness or connectors (The CAN communication line is open or shorted) ● Harness or connectors (The sensor circuit is open or shorted) ● Unified meter and A/C amp. ● Fuel level sensor

DTC Confirmation Procedure

ABS00C6X

NOTE:

If DTC Confirmation Procedure has been previously conducted, always turn ignition switch OFF and wait at least 10 seconds before conducting the next test.

WITH CONSULT-II

1. Turn ignition switch ON.
2. Select “DATA MONITOR” mode with CONSULT-II.
3. Start engine and wait maximum of 2 consecutive minutes.
4. If 1st trip DTC is detected, go to [EC-1041](#), “[Diagnostic Procedure](#)”.

DATA MONITOR	
MONITOR	NO DTC
FUEL T/TMP SE	XXX °C
FUEL LEVEL SE	XXX V

SEF195Y

WITH GST

Follow the procedure “WITH CONSULT-II” above.

Diagnostic Procedure

ABS00C6Y

1. CHECK DTC WITH "UNIFIED METER AND A/C AMP."

A

Refer to [DI-32, "SELF-DIAGNOSTIC RESULTS"](#) .

OK or NG

OK >> GO TO 2.

NG >> Go to [DI-20, "Fuel Level Sensor Signal Inspection 1"](#) .

EC

2. CHECK INTERMITTENT INCIDENT

C

Refer to [EC-784, "TROUBLE DIAGNOSIS FOR INTERMITTENT INCIDENT"](#) .

D

>> INSPECTION END

Removal and Installation FUEL LEVEL SENSOR

ABS00C6Z

Refer to [FL-4, "FUEL LEVEL SENSOR UNIT, FUEL FILTER AND FUEL PUMP ASSEMBLY"](#)

E

F

G

H

I

J

K

L

M

DTC P0461 FUEL LEVEL SENSOR

PFP:25060

Component Description

ABS00C70

The fuel level sensor is mounted in the fuel level sensor unit. The sensor detects a fuel level in the fuel tank and transmits a signal to the “unified meter and A/C amp.”. The “unified meter and A/C amp.” sends the fuel level sensor signal to the ECM through CAN communication line.

It consists of two parts, one is mechanical float and the other is variable resistor. Fuel level sensor output voltage changes depending on the movement of the fuel mechanical float.

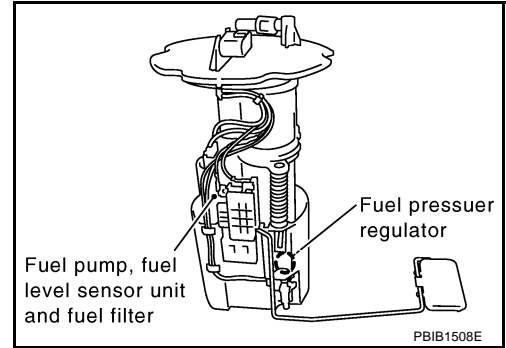

On Board Diagnosis Logic

ABS00C71

NOTE:

If DTC P0461 is displayed with DTC U1000 or U1001, first perform the trouble diagnosis for DTC U1000, U1001. Refer to [EC-792](#).

Driving long distances naturally affect fuel gauge level.

This diagnosis detects the fuel gauge malfunction of the gauge not moving even after a long distance has been driven.

DTC No.	Trouble diagnosis name	DTC detecting condition	Possible cause
P0461 0461	Fuel level sensor circuit range/performance	The output signal of the fuel level sensor does not change within the specified range even though the vehicle has been driven a long distance.	<ul style="list-style-type: none"> ● Harness or connectors (The CAN communication line is open or shorted) ● Harness or connectors (The sensor circuit is open or shorted) ● Unified meter and A/C amp. ● Fuel level sensor

Overall Function Check

ABS00C72

Use this procedure to check the overall function of the fuel level sensor function. During this check, a 1st trip DTC might not be confirmed.

WARNING:

When performing following procedure, be sure to observe the handling of the fuel. Refer to [FL-10, "FUEL TANK"](#).

TESTING CONDITION:

Before starting overall function check, preparation of draining fuel and refilling fuel is required.

WITH CONSULT-II

NOTE:

Start from step 10, if it is possible to confirm that the fuel cannot be drained by 30 ℓ (7-7/8 US gal, 6-5/8 Imp gal) in advance.

1. Prepare a fuel container and a spare hose.
2. Release fuel pressure from fuel line, refer to [EC-700, "FUEL PRESSURE RELEASE"](#).
3. Remove the fuel feed hose on the fuel level sensor unit.
4. Connect a spare fuel hose where the fuel feed hose was removed.
5. Turn ignition switch OFF and wait at least 10 seconds then turn ON.
6. Select “FUEL LEVEL SE” in “DATA MONITOR” mode with CONSULT-II.

DTC P0461 FUEL LEVEL SENSOR

[VK45DE]

7. Check "FUEL LEVEL SE" output voltage and note it.
8. Select "FUEL PUMP" in "ACTIVE TEST" mode with CONSULT-II.
9. Touch "ON" and drain fuel approximately 30 ℓ (7-7/8 US gal, 6-5/8 Imp gal) and stop it.
10. Check "FUEL LEVEL SE" output voltage and note it.
11. Fill fuel into the fuel tank for 30 ℓ (7-7/8 US gal, 6-5/8 Imp gal).
12. Check "FUEL LEVEL SE" output voltage and note it.
13. Confirm whether the voltage changes more than 0.03V during step 7 to 10 and 10 to 12.
If NG, go to [EC-1043, "Diagnostic Procedure"](#) .

DATA MONITOR	
MONITOR	NO DTC
FUEL T/TMP SE	XXX °C
FUEL LEVEL SE	XXX V

SEF195Y

WITH GST

NOTE:

Start from step 8, if it is possible to confirm that the fuel cannot be drained by 30 ℓ (7-7/8 US gal, 6-5/8 Imp gal) in advance.

1. Prepare a fuel container and a spare hose.
2. Release fuel pressure from fuel line. Refer to [EC-700, "FUEL PRESSURE RELEASE"](#) .
3. Remove the fuel feed hose on the fuel level sensor unit.
4. Connect a spare fuel hose where the fuel feed hose was removed.
5. Turn ignition switch ON.
6. Drain fuel by 30 ℓ (7-7/8 US gal, 6-5/8 Imp gal) from the fuel tank using proper equipment.
7. Confirm that the fuel gauge indication varies.
8. Fill fuel into the fuel tank for 30 ℓ (7-7/8 US gal, 6-5/8 Imp gal).
9. Confirm that the fuel gauge indication varies.
10. If NG, go to [EC-1043, "Diagnostic Procedure"](#) .

Diagnostic Procedure

ABS00C73

1. CHECK DTC WITH "UNIFIED METER AND A/C AMP."

Refer to [DI-32, "SELF-DIAGNOSTIC RESULTS"](#) .

OK or NG

- OK >> GO TO 2.
- NG >> Go to [DI-20, "Fuel Level Sensor Signal Inspection 1"](#) .

2. CHECK INTERMITTENT INCIDENT

Refer to [EC-784, "TROUBLE DIAGNOSIS FOR INTERMITTENT INCIDENT"](#) .

>> INSPECTION END

Removal and Installation FUEL LEVEL SENSOR

ABS00C74

Refer to [FL-4, "FUEL LEVEL SENSOR UNIT, FUEL FILTER AND FUEL PUMP ASSEMBLY"](#) .

DTC P0462, P0463 FUEL LEVEL SENSOR CIRCUIT

PFP:25060

Component Description

ABS00C75

The fuel level sensor is mounted in the fuel level sensor unit. The sensor detects a fuel level in the fuel tank and transmits a signal to the “unified meter and A/C amp.”. The “unified meter and A/C amp.” sends the fuel level sensor signal to the ECM through CAN communication line.

It consists of two parts, one is mechanical float and the other is variable resistor. Fuel level sensor output voltage changes depending on the movement of the fuel mechanical float.

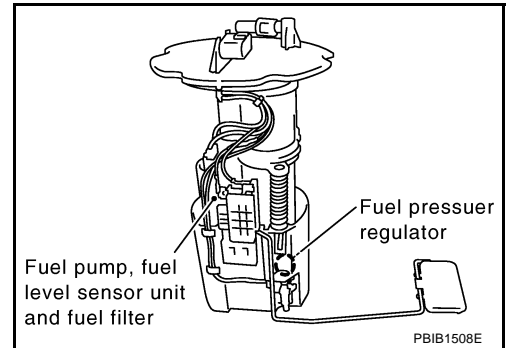

On Board Diagnosis Logic

ABS00C76

NOTE:

If DTC P0462 or P0463 is displayed with DTC U1000 or U1001, first perform the trouble diagnosis for DTC U1000, U1001. Refer to [EC-792](#).

This diagnosis indicates the former, to detect open or short circuit malfunction.

DTC No.	Trouble diagnosis name	DTC detecting condition	Possible cause
P0462 0462	Fuel level sensor circuit low input	An excessively low voltage from the sensor is sent to ECM.	<ul style="list-style-type: none"> ● Harness or connectors (The CAN communication line is open or shorted) ● Harness or connectors (The sensor circuit is open or shorted) ● Unified meter and A/C amp. ● Fuel level sensor
P0463 0463	Fuel level sensor circuit high input	An excessively high voltage from the sensor is sent to ECM.	

DTC Confirmation Procedure

ABS00C77

NOTE:

If DTC Confirmation Procedure has been previously conducted, always turn ignition switch OFF and wait at least 10 seconds before conducting the next test.

TESTING CONDITION:

Before performing the following procedure, confirm that battery voltage is more than 11V at ignition switch ON.

Ⓜ **WITH CONSULT-II**

1. Turn ignition switch ON.
2. Select “DATA MONITOR” mode with CONSULT-II.
3. Wait at least 5 seconds.
4. If 1st trip DTC is detected, go to [EC-1045, "Diagnostic Procedure"](#).

DATA MONITOR	
MONITOR	NO DTC
FUEL T/TMP SE	XXX °C
FUEL LEVEL SE	XXX V

SEF195Y

Ⓜ **WITH GST**

Follow the procedure “WITH CONSULT-II” above.

Diagnostic Procedure

ABS00C78

1. CHECK DTC WITH "UNIFIED METER AND A/C AMP."

Refer to [DI-32, "SELF-DIAGNOSTIC RESULTS"](#) .

OK or NG

OK >> GO TO 2.

NG >> Go to [DI-20, "Fuel Level Sensor Signal Inspection 1"](#) .

2. CHECK INTERMITTENT INCIDENT

Refer to [EC-784, "TROUBLE DIAGNOSIS FOR INTERMITTENT INCIDENT"](#) .

>> INSPECTION END

Removal and Installation FUEL LEVEL SENSOR

ABS00C79

Refer to [FL-4, "FUEL LEVEL SENSOR UNIT, FUEL FILTER AND FUEL PUMP ASSEMBLY"](#) .

A

EC

C

D

E

F

G

H

I

J

K

L

M

DTC P0500 VSS

PFP:32702

Description

ABS00C7A

NOTE:

If DTC P0500 is displayed with DTC U1000 or U1001, first perform the trouble diagnosis for DTC U1000, U1001. Refer to [EC-792, "DTC U1000, U1001 CAN COMMUNICATION LINE"](#).

The vehicle speed signal is sent to the "unified meter and A/C amp." from the "ABS actuator and electric unit (control unit)" by CAN communication line. The "unified meter and A/C amp." then sends a signal to the ECM by CAN communication line.

On Board Diagnosis Logic

ABS00C7B

DTC No.	Trouble diagnosis name	DTC detecting condition	Possible cause
P0500 0500	Vehicle speed sensor	The almost 0 km/h (0 MPH) signal from vehicle speed sensor is sent to ECM even when vehicle is being driven.	<ul style="list-style-type: none"> ● Harness or connectors (The CAN communication line is open or shorted) ● Harness or connectors (The vehicle speed signal circuit is open or shorted) ● Wheel sensor ● Unified meter and A/C amp. ● ABS actuator and electric unit (control unit)

DTC Confirmation Procedure

ABS00C7C

CAUTION:

Always drive vehicle at a safe speed.

NOTE:

If DTC Confirmation Procedure has been previously conducted, always turn ignition switch OFF and wait at least 10 seconds before conducting the next test.

TESTING CONDITION:

Steps 1 and 2 may be conducted with the drive wheels lifted in the shop or by driving the vehicle. If a road test is expected to be easier, it is unnecessary to lift the vehicle.

WITH CONSULT-II

1. Start engine (VDC switch OFF).
2. Read "VHCL SPEED SE" in "DATA MONITOR" mode with CONSULT-II. The vehicle speed on CONSULT-II should exceed 10 km/h (6 MPH) when rotating wheels with suitable gear position.
If NG, go to [EC-1047, "Diagnostic Procedure"](#).
If OK, go to following step.
3. Select "DATA MONITOR" mode with CONSULT-II.
4. Warm engine up to normal operating temperature.
5. Maintain the following conditions for at least 60 consecutive seconds.

ENG SPEED	1,600 - 6,000 rpm
COOLAN TEMP/S	More than 70°C (158°F)
B/FUEL SCHDL	More than 4.5 msec
Selector lever	Except P or N position
PW/ST SIGNAL	OFF

6. If 1st trip DTC is detected, go to [EC-1047, "Diagnostic Procedure"](#).

DATA MONITOR	
MONITOR	NO DTC
ENG SPEED	XXX rpm
COOLAN TEMP/S	XXX °C
B/FUEL SCHDL	XXX msec
PW/ST SIGNAL	OFF
VHCL SPEED SE	XXX km/h

SEF196Y

Overall Function Check

ABS00C7D

Use this procedure to check the overall function of the vehicle speed sensor circuit. During this check, a 1st trip DTC might not be confirmed.

 WITH GST

1. Lift up drive wheels.
2. Start engine.
3. Read vehicle speed sensor signal in MODE 1 with GST.
The vehicle speed sensor on GST should be able to exceed 10 km/h (6 MPH) when rotating wheels with suitable gear position.
4. If NG, go to [EC-1047, "Diagnostic Procedure"](#) .

Diagnostic Procedure

ABS00C7E

1. CHECK DTC WITH "ABS ACTUATOR AND ELECTRIC UNIT (CONTROL UNIT)"

Refer to [BRC-12, "TROUBLE DIAGNOSIS"](#) .

OK or NG

- OK >> GO TO 2.
NG >> Repair or replace.

2. CHECK DTC WITH "UNIFIED METER AND A/C AMP."

Refer to [DI-4, "COMBINATION METERS"](#) .

>> **INSPECTION END**

A

EC

C

D

E

F

G

H

I

J

K

L

M

DTC P0506 ISC SYSTEM

PFP:23781

Description

ABS00C7F

NOTE:

If DTC P0506 is displayed with other DTC, first perform the trouble diagnosis for the other DTC.

The ECM controls the engine idle speed to a specified level through the fine adjustment of the air, which is let into the intake manifold, by operating the electric throttle control actuator. The operating of the throttle valve is varied to allow for optimum control of the engine idling speed. The crankshaft position sensor (POS) detects the actual engine speed and sends a signal to the ECM.

The ECM controls the electric throttle control actuator so that the engine speed coincides with the target value memorized in the ECM. The target engine speed is the lowest speed at which the engine can operate steadily. The optimum value stored in the ECM is determined by taking into consideration various engine conditions, such as during warming up, deceleration, and engine load (air conditioner, power steering and cooling fan operation, etc.).

On Board Diagnosis Logic

ABS00C7G

DTC No.	Trouble diagnosis name	DTC detecting condition	Possible cause
P0506 0506	Idle speed control system RPM lower than expected	The idle speed is less than the target idle speed by 100 rpm or more.	<ul style="list-style-type: none"> ● Electric throttle control actuator ● Intake air leak

DTC Confirmation Procedure

ABS00C7H

NOTE:

- If DTC Confirmation Procedure has been previously conducted, always turn ignition switch OFF and wait at least 10 seconds before conducting the next test.
- **If the target idle speed is out of the specified value, perform Idle Air Volume Learning, [EC-698](#) , before conducting DTC Confirmation Procedure. For the target idle speed, refer to the [EC-1336](#), "[SERVICE DATA AND SPECIFICATIONS \(SDS\)](#)".**

TESTING CONDITION:

- Before performing the following procedure, confirm that battery voltage is more than 11V at idle.
- Always perform the test at a temperature above -10°C (14°F).

WITH CONSULT-II

1. Open engine hood.
2. Start engine and warm it up to normal operating temperature.
3. Turn ignition switch OFF and wait at least 10 seconds.
4. Turn ignition switch ON again and select "DATA MONITOR" mode with CONSULT-II.
5. Start engine and run it for at least 1 minute at idle speed.
6. If 1st trip DTC is detected, go to [EC-1049](#), "[Diagnostic Procedure](#)".

DATA MONITOR	
MONITOR	NO DTC
ENG SPEED	XXX rpm
COOLAN TEMP/S	XXX °C

SEF174Y

WITH GST

Follow the procedure "WITH CONSULT-II" above.

Diagnostic Procedure**1. CHECK INTAKE AIR LEAK**

1. Start engine and let it idle.
2. Listen for an intake air leak after the mass air flow sensor.

OK or NG

- OK >> GO TO 2.
NG >> Discover air leak location and repair.

2. REPLACE ECM

1. Stop engine.
2. Replace ECM.
3. Perform initialization of NATS system and registration of all NATS ignition key IDs. Refer to [BL-208, "ECM Re-communicating Function"](#).
4. Perform [EC-698, "Accelerator Pedal Released Position Learning"](#).
5. Perform [EC-698, "Throttle Valve Closed Position Learning"](#).
6. Perform [EC-698, "Idle Air Volume Learning"](#).

>> INSPECTION END

A

EC

C

D

E

F

G

H

I

J

K

L

M

DTC P0507 ISC SYSTEM

PFP:23781

Description

ABS00C7J

NOTE:

If DTC P0507 is displayed with other DTC, first perform the trouble diagnosis for the other DTC.

The ECM controls the engine idle speed to a specified level through the fine adjustment of the air, which is let into the intake manifold, by operating the electric throttle control actuator. The operating of the throttle valve is varied to allow for optimum control of the engine idling speed. The crankshaft position sensor (POS) detects the actual engine speed and sends a signal to the ECM.

The ECM controls the electric throttle control actuator so that the engine speed coincides with the target value memorized in the ECM. The target engine speed is the lowest speed at which the engine can operate steadily. The optimum value stored in the ECM is determined by taking into consideration various engine conditions, such as during warming up, deceleration, and engine load (air conditioner, power steering and cooling fan operation, etc.).

On Board Diagnosis Logic

ABS00C7K

DTC No.	Trouble diagnosis name	DTC detecting condition	Possible cause
P0507 0507	Idle speed control system RPM higher than expected	The idle speed is more than the target idle speed by 200 rpm or more.	<ul style="list-style-type: none"> ● Electric throttle control actuator ● Intake air leak ● PCV system

DTC Confirmation Procedure

ABS00C7L

NOTE:

- If DTC Confirmation Procedure has been previously conducted, always turn ignition switch OFF and wait at least 10 seconds before conducting the next test.
- **If the target idle speed is out of the specified value, perform Idle Air Volume Learning, [EC-698](#) , before conducting DTC Confirmation Procedure. For the target idle speed, refer to the [EC-1336](#). "[SERVICE DATA AND SPECIFICATIONS \(SDS\)](#)".**

TESTING CONDITION:

- Before performing the following procedure, confirm that battery voltage is more than 11V at idle.
- Always perform the test at a temperature above -10°C (14°F).

WITH CONSULT-II

1. Open engine hood.
2. Start engine and warm it up to normal operating temperature.
3. Turn ignition switch OFF and wait at least 10 seconds.
4. Turn ignition switch ON again and select "DATA MONITOR" mode with CONSULT-II.
5. Start engine and run it for at least 1 minute at idle speed.
6. If 1st trip DTC is detected, go to [EC-1051](#), "[Diagnostic Procedure](#)".

DATA MONITOR	
MONITOR	NO DTC
ENG SPEED	XXX rpm
COOLAN TEMP/S	XXX °C

SEF174Y

WITH GST

Follow the procedure "WITH CONSULT-II" above.

Diagnostic Procedure**1. CHECK PCV HOSE CONNECTION**

Confirm that PCV hose is connected correctly.

OK or NG

OK >> GO TO 2.

NG >> Repair or replace.

2. CHECK INTAKE AIR LEAK

1. Start engine and let it idle.
2. Listen for an intake air leak after the mass air flow sensor.

OK or NG

OK >> GO TO 3.

NG >> Discover air leak location and repair.

3. REPLACE ECM

1. Stop engine.
2. Replace ECM.
3. Perform initialization of NATS system and registration of all NATS ignition key IDs. Refer to [BL-208, "ECM Re-communicating Function"](#) .
4. Perform [EC-698, "Accelerator Pedal Released Position Learning"](#) .
5. Perform [EC-698, "Throttle Valve Closed Position Learning"](#) .
6. Perform [EC-698, "Idle Air Volume Learning"](#) .

>> **INSPECTION END**

A

EC

C

D

E

F

G

H

I

J

K

L

M

DTC P0550 PSP SENSOR

PFP:49763

Component Description

ABS00C7N

Power steering pressure (PSP) sensor is installed to the power steering high-pressure tube and detects a power steering load. This sensor is a potentiometer which transforms the power steering load into output voltage, and emits the voltage signal to the ECM. The ECM controls the electric throttle control actuator and adjusts the throttle valve opening angle to increase the engine speed and adjusts the idle speed for the increased load.

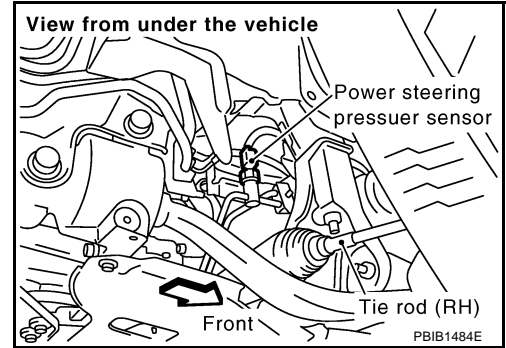

CONSULT-II Reference Value in Data Monitor Mode

ABS00C7O

Specification data are reference values.

MONITOR ITEM	CONDITION		SPECIFICATION
PW/ST SIGNAL	<ul style="list-style-type: none"> Engine: After warming up, idle the engine 	Steering wheel is in neutral position (Forward direction)	OFF
		Steering wheel is turned	ON

On Board Diagnosis Logic

ABS00C7P

The MIL will not light up for this diagnosis.

NOTE:

If DTC P0550 is displayed with DTC P1229, first perform the trouble diagnosis for DTC P1229. Refer to [EC-1156](#).

DTC No.	Trouble diagnosis name	DTC detecting condition	Possible cause
P0550 0550	Power steering pressure sensor circuit	An excessively low or high voltage from the sensor is sent to ECM.	<ul style="list-style-type: none"> Harness or connectors (The sensor circuit is open or shorted) Power steering pressure sensor

DTC Confirmation Procedure

ABS00C7Q

NOTE:

If DTC Confirmation Procedure has been previously conducted, always turn ignition switch OFF and wait at least 10 seconds before conducting the next test.

Ⓜ **WITH CONSULT-II**

- Turn ignition switch ON.
- Select "DATA MONITOR" mode with CONSULT-II.
- Start engine and let it idle for at least 5 seconds.
- If 1st trip DTC is detected, go to [EC-1054, "Diagnostic Procedure"](#).

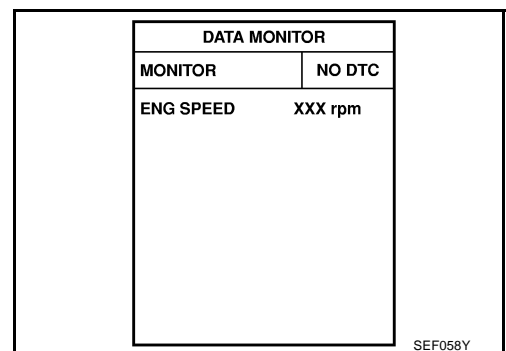

Ⓜ **WITH GST**

Follow the procedure "WITH CONSULT-II" above.

DTC P0550 PSP SENSOR

[VK45DE]

ABS00C7R

Wiring Diagram

EC-PS/SEN-01

: DETECTABLE LINE FOR DTC
 : NON-DETECTABLE LINE FOR DTC

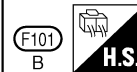
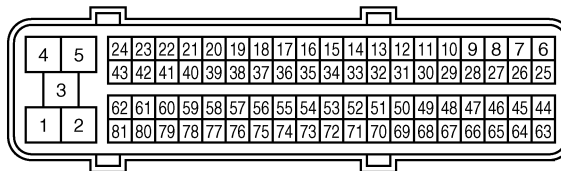
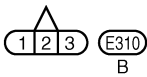
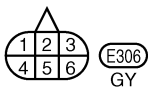
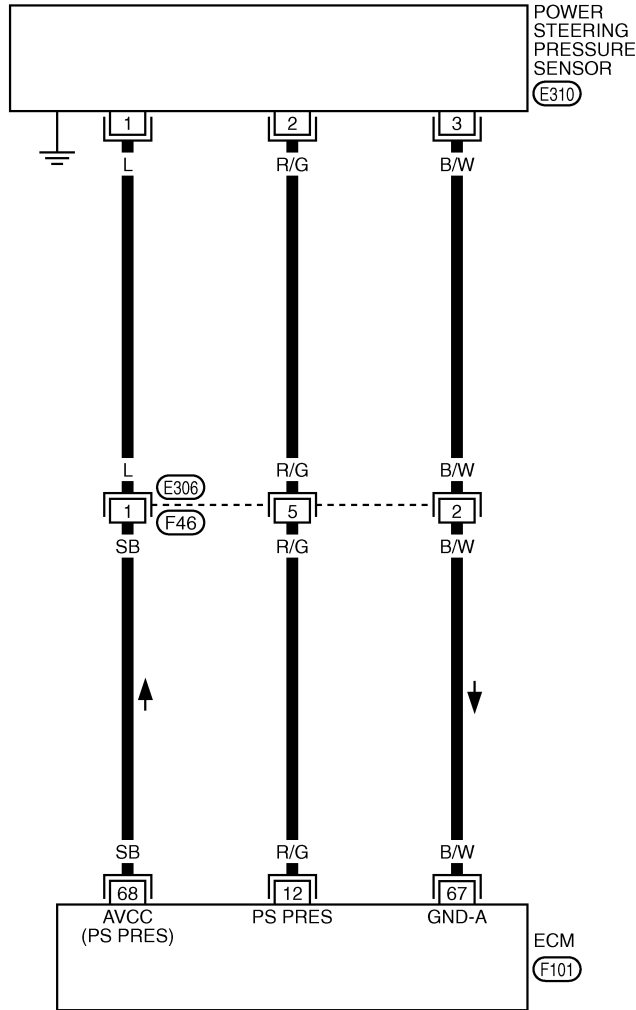

TBWM0249E

DTC P0550 PSP SENSOR

[VK45DE]

Specification data are reference values and are measured between each terminal and ground.

CAUTION:

Do not use ECM ground terminals when measuring input/output voltage. Doing so may result in damage to the ECM's transistor. Use a ground other than ECM terminals, such as the ground.

TER-MINAL NO.	WIRE COLOR	ITEM	CONDITION	DATA (DC Voltage)
12	R/G	Power steering pressure sensor	[Engine is running] ● Steering wheel is being turned	0.5 - 4.5V
			[Engine is running] ● Steering wheel is not being turned	0.4 - 0.8V
67	B/W	Sensor ground (Mass air flow sensor / IAT sensor / Power steering pressure sensor / EVAP control system pressure sensor / Refrigerant pressure sensor / ECT sensor)	[Engine is running] ● Warm-up condition ● Idle speed	Approximately 0V
68	SB	Sensor power supply (Power steering pressure sensor)	[Ignition switch: ON]	Approximately 5V

Diagnostic Procedure

ABS00C7S

1. CHECK GROUND CONNECTIONS

1. Turn ignition switch OFF.
2. Loosen and retighten three ground screws on the body.
Refer to [EC-791, "Ground Inspection"](#) .

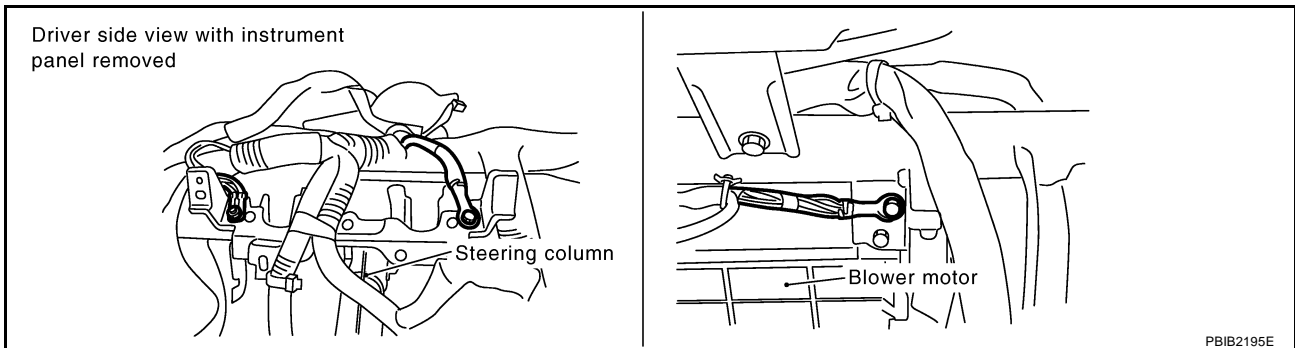

OK or NG

- OK >> GO TO 2.
- NG >> Repair or replace ground connections.

2. CHECK PSP SENSOR POWER SUPPLY CIRCUIT

1. Disconnect PSP sensor harness connector.
2. Turn ignition switch ON.

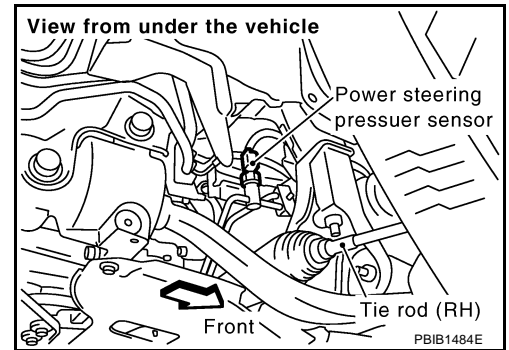

3. Check voltage between PSP sensor terminal 1 and ground with CONSULT-II or tester.

Voltage: Approximately 5V

OK or NG

- OK >> GO TO 4.
- NG >> GO TO 3.

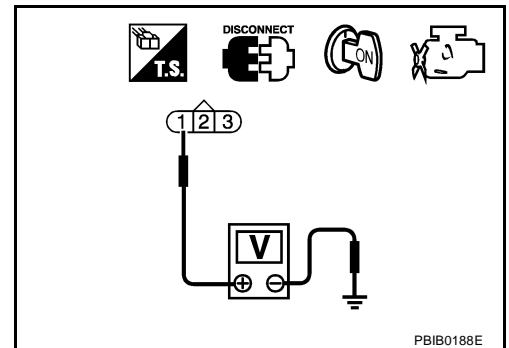

3. DETECT MALFUNCTIONING PART

Check the following.

- Harness connectors E306, F46
- Harness for open or short between power steering pressure sensor and ECM

>> Repair open circuit or short to power in harness or connectors.

4. CHECK PSP SENSOR GROUND CIRCUIT FOR OPEN AND SHORT

1. Turn ignition switch OFF.
2. Disconnect ECM harness connector.
3. Check harness continuity between PSP sensor terminal 3 and ECM terminal 67. Refer to Wiring Diagram.

Continuity should exist.

4. Also check harness for short to ground and short to power.

OK or NG

- OK >> GO TO 6.
- NG >> GO TO 5.

5. DETECT MALFUNCTIONING PART

Check the following.

- Harness connectors E306, F46
- Harness for open or short between power steering pressure sensor and ECM

>> Repair open circuit or short to ground short to power in harness or connectors.

6. CHECK PSP SENSOR INPUT SIGNAL CIRCUIT FOR OPEN AND SHORT

1. Check harness continuity between ECM terminal 12 and PSP sensor terminal 2.

Continuity should exist.

2. Also check harness for short to ground and short to power.

OK or NG

- OK >> GO TO 8.
- NG >> GO TO 7.

7. DETECT MALFUNCTIONING PART

Check the following.

- Harness connectors E306, F46
- Harness for open or short between power steering pressure sensor and ECM

>> Repair open circuit or short to power in harness or connectors.

8. CHECK PSP SENSOR

Refer to [EC-1056, "Component Inspection"](#) .

OK or NG

- OK >> GO TO 9.
- NG >> Replace PSP sensor.

9. CHECK INTERMITTENT INCIDENT

Refer to [EC-784, "TROUBLE DIAGNOSIS FOR INTERMITTENT INCIDENT"](#) .

>> **INSPECTION END**

Component Inspection POWER STEERING PRESSURE SENSOR

ABS00C7T

1. Reconnect all harness connectors disconnected.
2. Start engine and let it idle.
3. Check voltage between ECM terminal 12 and ground under the following conditions.

Condition	Voltage
Steering wheel is being turned.	0.5 - 4.5V
Steering wheel is not being turned.	0.4 - 0.8V

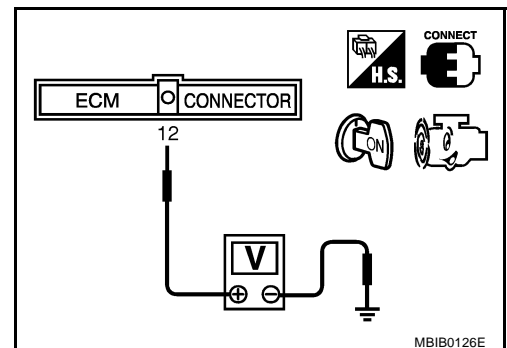

ABS00C7U

Removal and Installation POWER STEERING PRESSURE SENSOR

Refer to [PS-41, "HYDRAULIC LINE"](#) .

DTC P0605 ECM

PF2:23710

Component Description

ABS00C7V

The ECM consists of a microcomputer and connectors for signal input and output and for power supply. The ECM controls the engine.

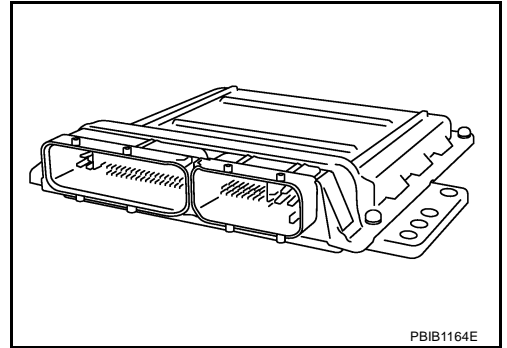

ABS00C7W

On Board Diagnosis Logic

This self-diagnosis has one or two trip detection logic.

DTC No.	Trouble diagnosis name	DTC detecting condition		Possible cause
P0605 0605	Engine control module	A)	ECM calculation function is malfunctioning.	● ECM
		B)	ECM EEPROM system is malfunctioning.	
		C)	ECM self shut-off function is malfunctioning.	

FAIL-SAFE MODE

ECM enters fail-safe mode when the malfunction A is detected.

Detected items	Engine operation condition in fail-safe mode
Malfunction A	<ul style="list-style-type: none"> ● ECM stops the electric throttle control actuator control, throttle valve is maintained at a fixed opening (approx. 5 degrees) by the return spring. ● ECM deactivates ASCD operation.

DTC Confirmation Procedure

ABS00C7X

Perform **PROCEDURE FOR MALFUNCTION A** first. If the 1st trip DTC cannot be confirmed, perform **PROCEDURE FOR MALFUNCTION B**. If there is no malfunction on **PROCEDURE FOR MALFUNCTION B**, perform **PROCEDURE FOR MALFUNCTION C**.

NOTE:

If DTC Confirmation Procedure has been previously conducted, always turn ignition switch OFF and wait at least 10 seconds before conducting the next test.

PROCEDURE FOR MALFUNCTION A

Ⓟ **With CONSULT-II**

1. Turn ignition switch ON.
2. Select "DATA MONITOR" mode with CONSULT-II.
3. If 1st trip DTC is detected, go to [EC-1058, "Diagnostic Procedure"](#).

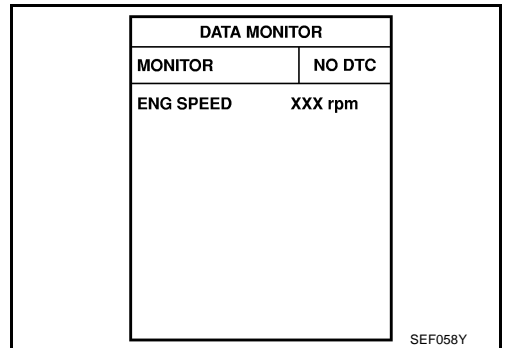

Ⓟ **With GST**

Follow the procedure "With CONSULT-II" above.

PROCEDURE FOR MALFUNCTION B

With CONSULT-II

1. Turn ignition switch ON and wait at least 1 second.
2. Select "DATA MONITOR" mode with CONSULT-II.
3. Turn ignition switch OFF, wait at least 10 seconds, and then turn ON.
4. If 1st trip DTC is detected, go to [EC-1058, "Diagnostic Procedure"](#).

DATA MONITOR	
MONITOR	NO DTC
ENG SPEED	XXX rpm

SEF058Y

With GST

Follow the procedure "With CONSULT-II" above.

PROCEDURE FOR MALFUNCTION C

With CONSULT-II

1. Turn ignition switch ON and wait at least 1 second.
2. Select "DATA MONITOR" mode with CONSULT-II.
3. Turn ignition switch OFF, wait at least 10 seconds, and then turn ON.
4. Repeat step 3 for 32 times.
5. If 1st trip DTC is detected, go to [EC-1058, "Diagnostic Procedure"](#).

DATA MONITOR	
MONITOR	NO DTC
ENG SPEED	XXX rpm

SEF058Y

With GST

Follow the procedure "With CONSULT-II" above.

Diagnostic Procedure

ABS00C7Y

1. INSPECTION START

With CONSULT-II

1. Turn ignition switch ON.
2. Select "SELF DIAG RESULTS" mode with CONSULT-II.
3. Touch "ERASE".
4. **Perform DTC Confirmation Procedure.**
See [EC-1057, "DTC Confirmation Procedure"](#).
5. Is the 1st trip DTC P0605 displayed again?

With GST

1. Turn ignition switch ON.
2. Select MODE 4 with GST.
3. Touch "ERASE".
4. **Perform DTC Confirmation Procedure.**
See [EC-1057, "DTC Confirmation Procedure"](#).
5. Is the 1st trip DTC P0605 displayed again?

Yes or No

Yes >> GO TO 2.

No >> **INSPECTION END**

2. REPLACE ECM

1. Replace ECM.
2. Perform initialization of NATS system and registration of all NATS ignition key IDs. Refer to [BL-208, "ECM Re-communicating Function"](#) .
3. Perform [EC-698, "Accelerator Pedal Released Position Learning"](#) .
4. Perform [EC-698, "Throttle Valve Closed Position Learning"](#) .
5. Perform [EC-698, "Idle Air Volume Learning"](#) .

>> INSPECTION END

A

EC

C

D

E

F

G

H

I

J

K

L

M

DTC P1065 ECM POWER SUPPLY

PFP:23710

Component Description

ABS00C7Z

Battery voltage is supplied to the ECM even when the ignition switch is turned OFF for the ECM memory function of the DTC memory, the air-fuel ratio feedback compensation value memory, the idle air volume learning value memory, etc.

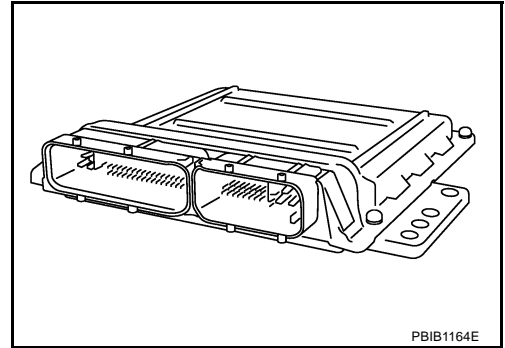

On Board Diagnosis Logic

ABS00C80

DTC No.	Trouble diagnosis name	DTC detecting condition	Possible cause
P1065 1065	ECM power supply circuit	ECM back-up RAM system does not function properly.	<ul style="list-style-type: none"> ● Harness or connectors [ECM power supply (back-up) circuit is open or shorted.] ● ECM

DTC Confirmation Procedure

ABS00C81

NOTE:

If DTC Confirmation Procedure has been previously conducted, always turn ignition switch OFF and wait at least 10 seconds before conducting the next test.

WITH CONSULT-II

1. Turn ignition switch ON and wait at least 1 second.
2. Select "DATA MONITOR" mode with CONSULT-II.
3. Start engine and let it idle for 1 second.
4. Turn ignition switch OFF, wait at least 10 seconds, and then turn ON.
5. Repeat steps 3 and 4 for 4 times.
6. If 1st trip DTC is detected, go to [EC-1062. "Diagnostic Procedure"](#).

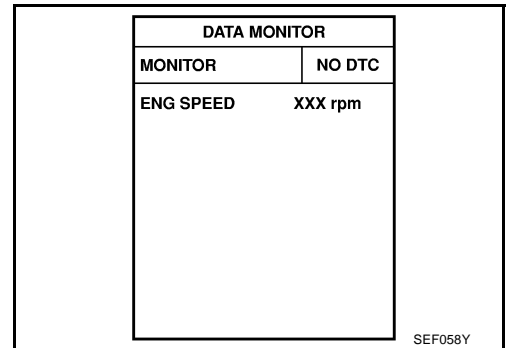

WITH GST

Follow the procedure "WITH CONSULT-II" above.

DTC P1065 ECM POWER SUPPLY

[VK45DE]

Wiring Diagram

ABS00C82

EC-ECM/PW-01

: DETECTABLE LINE FOR DTC
 : NON-DETECTABLE LINE FOR DTC

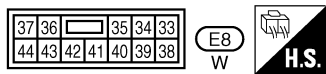
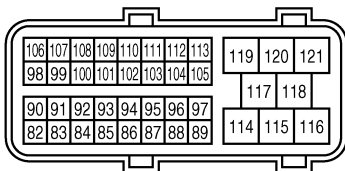
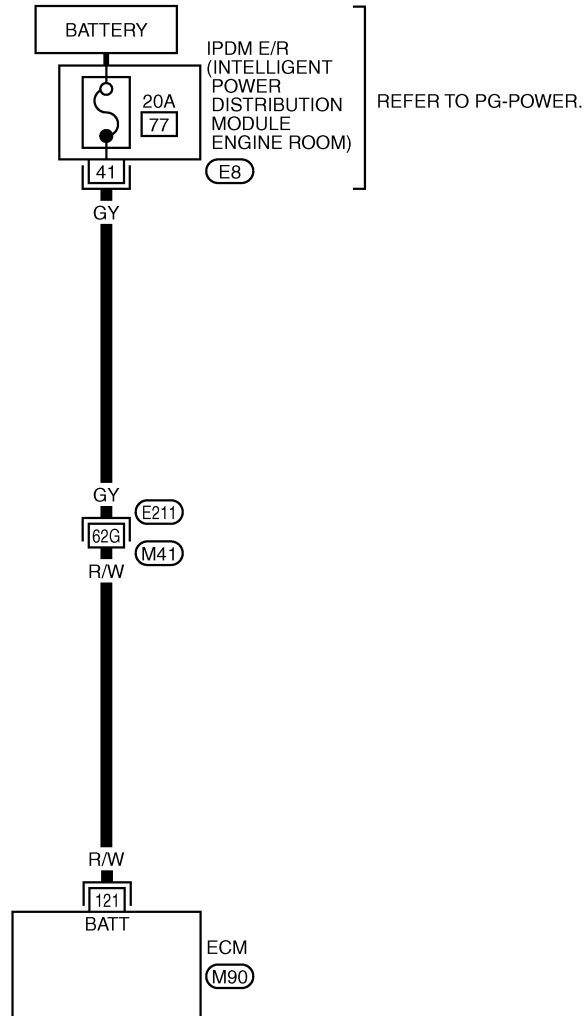

REFER TO THE FOLLOWING.
 (E211) -SUPER MULTIPLE
 JUNCTION (SMJ)

TBWM0250E

DTC P1065 ECM POWER SUPPLY

[VK45DE]

Specification data are reference values and are measured between each terminal and ground.

CAUTION:

Do not use ECM ground terminals when measuring input/output voltage. Doing so may result in damage to the ECM's transistor. Use a ground other than ECM terminals, such as the ground.

TER-MINAL NO.	WIRE COLOR	ITEM	CONDITION	DATA (DC Voltage)
121	R/W	Power supply for ECM (Back-up)	[Ignition switch: OFF]	BATTERY VOLTAGE (11 - 14V)

Diagnostic Procedure

ABS00C83

1. CHECK ECM POWER SUPPLY

1. Turn ignition switch OFF.
2. Disconnect ECM harness connector.
3. Check voltage between ECM terminal 121 and ground with CONSULT-II or tester.

Voltage: Battery voltage

OK or NG

- OK >> GO TO 3.
- NG >> GO TO 2.

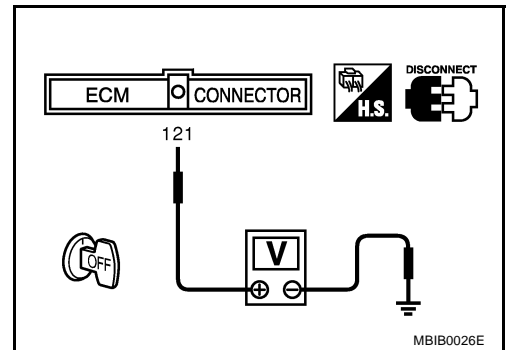

2. DETECT MALFUNCTIONING PART

Check the following.

- Harness connectors E211, M41
- 20A fuse
- IPDM E/R harness connector E8
- Harness for open or short between ECM and battery

>> Repair or replace harness or connectors.

3. CHECK INTERMITTENT INCIDENT

Refer to [EC-784, "TROUBLE DIAGNOSIS FOR INTERMITTENT INCIDENT"](#).

OK or NG

- OK >> GO TO 4.
- NG >> Repair or replace harness or connectors.

4. PERFORM DTC CONFIRMATION PROCEDURE**Ⓜ With CONSULT-II**

1. Turn ignition switch ON.
2. Select "SELF DIAG RESULTS" mode with CONSULT-II.
3. Touch "ERASE".
4. **Perform DTC Confirmation Procedure.**
See [EC-1060, "DTC Confirmation Procedure"](#) .
5. Is the 1st trip DTC P1065 displayed again?

Ⓜ With GST

1. Turn ignition switch ON.
2. Select MODE 4 with GST.
3. Touch "ERASE".
4. **Perform DTC Confirmation Procedure.**
See [EC-1060, "DTC Confirmation Procedure"](#) .
5. Is the 1st trip DTC P1065 displayed again?

Yes or No

Yes >> GO TO 5.

No >> **INSPECTION END**

5. REPLACE ECM

1. Replace ECM.
2. Perform initialization of NATS system and registration of all NATS ignition key IDs. Refer to [BL-208, "ECM Re-communicating Function"](#) .
3. Perform [EC-698, "Accelerator Pedal Released Position Learning"](#) .
4. Perform [EC-698, "Throttle Valve Closed Position Learning"](#) .
5. Perform [EC-698, "Idle Air Volume Learning"](#) .

>> **INSPECTION END**

DTC P1102 MAF SENSOR

PFP:22680

Component Description

ABS00C84

The mass air flow sensor is placed in the stream of intake air. It measures the intake flow rate by measuring a part of the entire intake flow. It consists of a hot film that is supplied with electric current from the ECM. The temperature of the hot film is controlled by the ECM a certain amount. The heat generated by the hot film is reduced as the intake air flows around it. The more air, the greater the heat loss. Therefore, the ECM must supply more electric current to maintain the temperature of the hot film as air flow increases. The ECM detects the air flow by means of this current change.

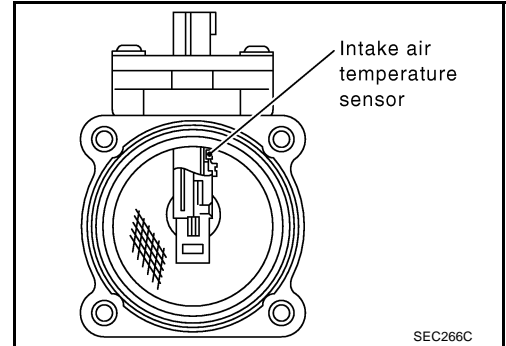

CONSULT-II Reference Value in Data Monitor Mode

ABS00C85

Specification data are reference values.

MONITOR ITEM	CONDITION		SPECIFICATION
MAS A/F SE-B1	See EC-780, "TROUBLE DIAGNOSIS - SPECIFICATION VALUE" .		
CAL/LD VALUE	<ul style="list-style-type: none"> ● Engine: After warming up ● Air conditioner switch: OFF ● Shift lever: N ● No load 	Idle	14% - 33%
		2,500 rpm	12% - 25%
MASS AIRFLOW	<ul style="list-style-type: none"> ● Engine: After warming up ● Air conditioner switch: OFF ● Shift lever: N ● No load 	Idle	2.0 - 6.0 g-m/s
		2,500 rpm	7.0 - 20.0 g-m/s

On Board Diagnosis Logic

ABS00C86

These self-diagnoses have the one trip detection logic.

NOTE:

If DTC P1102 is displayed with DTC P1229, first perform the trouble diagnosis for DTC P1229. Refer to [EC-1156](#) .

DTC No.	Trouble diagnosis name	DTC detecting condition	Possible cause
P1102 1102	Mass air flow sensor circuit range / performance problem	A voltage from the sensor is constantly approximately 1.0V when engine running.	<ul style="list-style-type: none"> ● Harness or connectors (The sensor circuit is open or shorted.) ● Mass air flow sensor

FAIL-SAFE MODE

When the malfunction is detected, the ECM enters fail-safe mode and the MIL lights up.

Detected items	Engine operating condition in fail-safe mode
Mass air flow sensor circuit	Engine speed will not rise more than 2,400 rpm due to the fuel cut.

DTC Confirmation Procedure

NOTE:

If DTC Confirmation Procedure has been previously conducted, always turn ignition switch OFF and wait at least 10 seconds before conducting the next test.

WITH CONSULT-II

1. Turn ignition switch ON.
2. Select "DATA MONITOR" mode with CONSULT-II.
3. Start engine and wait at least 5 seconds.
4. If DTC is detected, go to [EC-1067, "Diagnostic Procedure"](#) .

DATA MONITOR	
MONITOR	NO DTC
ENG SPEED	XXX rpm

SEF058Y

WITH GST

Follow the procedure "WITH CONSULT-II" above.

A
EC
C
D
E
F
G
H
I
J
K
L
M

DTC P1102 MAF SENSOR

[VK45DE]

ABS00C88

Wiring Diagram

EC-MAFS-01

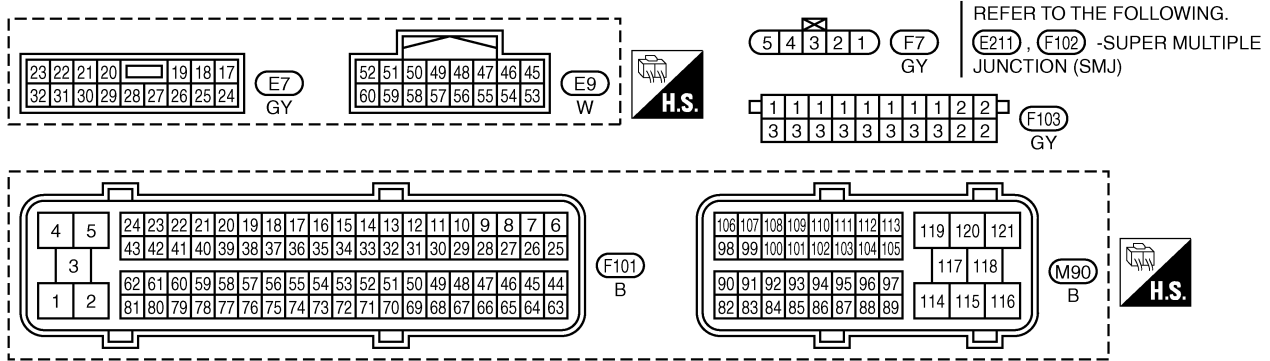
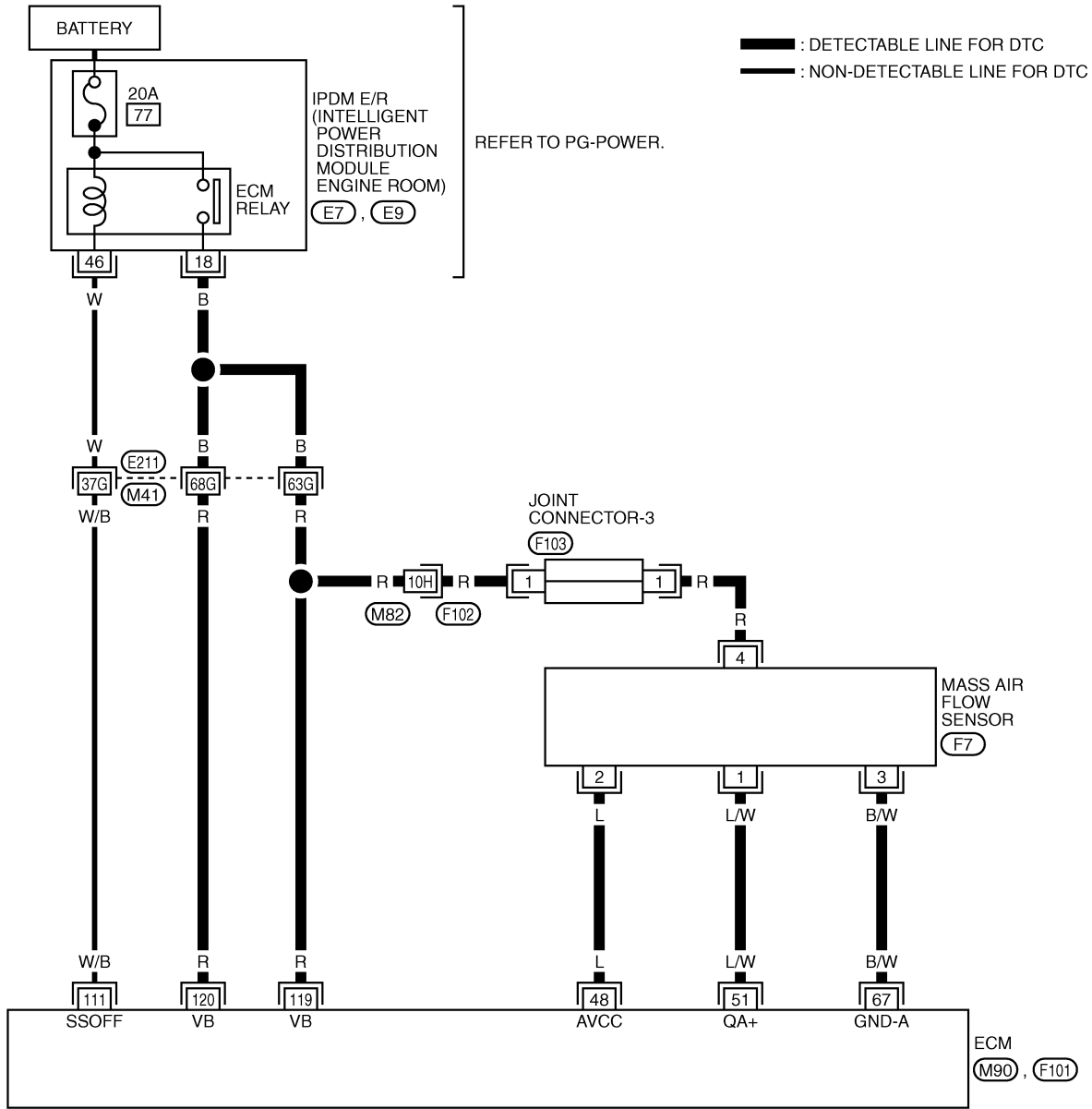

TBWM0225E

DTC P1102 MAF SENSOR

[VK45DE]

Specification data are reference values and are measured between each terminal and ground.

CAUTION:

Do not use ECM ground terminals when measuring input/output voltage. Doing so may result in damage to the ECM's transistor. Use a ground other than ECM terminals, such as the ground.

TER-MINAL NO.	WIRE COLOR	ITEM	CONDITION	DATA (DC Voltage)
48	L	Sensor power supply (Mass air flow sensor)	[Ignition switch: ON]	Approximately 5V
51	L/W	Mass air flow sensor	[Engine is running] ● Warm-up condition ● Idle speed	1.2 - 1.8V
			[Engine is running] ● Warm-up condition ● Engine speed is 2,500 rpm	1.7 - 2.4V
67	B/W	Sensor ground (Mass air flow sensor / IAT sensor / Power steering pressure sensor / EVAP control system pressure sensor / Refrigerant pressure sensor / ECT sensor)	[Engine is running] ● Warm-up condition ● Idle speed	Approximately 0V
111	W/B	ECM relay (Self shut-off)	[Engine is running] [Ignition switch: OFF] ● For a few seconds after turning ignition switch OFF	0 - 1.5V
			[Ignition switch: OFF] ● More than a few seconds after turning ignition switch OFF	BATTERY VOLTAGE (11 - 14V)
119 120	R R	Power supply for ECM	[Ignition switch: ON]	BATTERY VOLTAGE (11 - 14V)

Diagnostic Procedure

ABS00C89

1. CHECK GROUND CONNECTIONS

1. Turn ignition switch OFF.
2. Loosen and retighten three ground screws on the body. Refer to [EC-791, "Ground Inspection"](#).

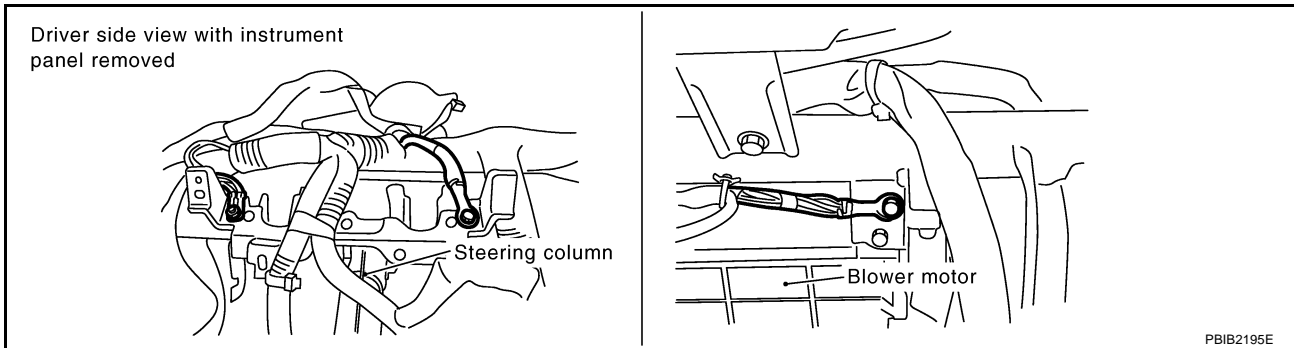

PBIB2195E

OK or NG

- OK >> GO TO 2.
- NG >> Repair or replace ground connections.

2. CHECK MAF SENSOR POWER SUPPLY CIRCUIT

1. Disconnect mass air flow (MAF) sensor harness connector.
2. Turn ignition switch ON.

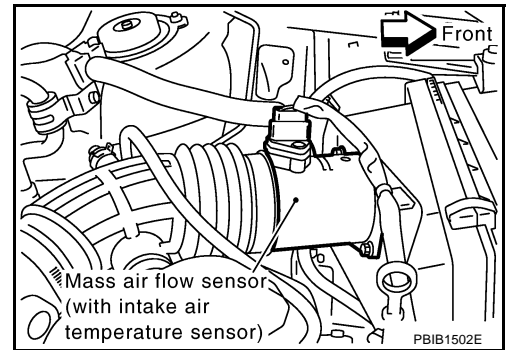

3. Check voltage between MAF sensor terminals 2, 4 and ground with CONSULT-II or tester.

Terminal	Voltage
2	Approximately 5V
4	Battery voltage

OK or NG

- OK >> GO TO 4.
- NG >> GO TO 3.

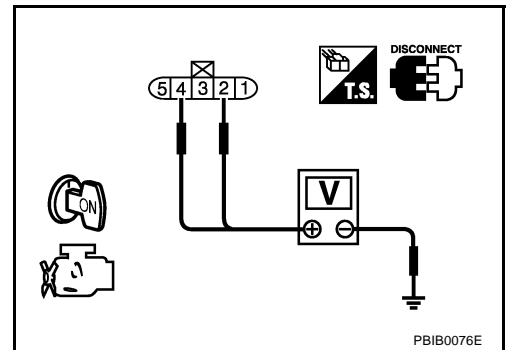

3. DETECT MALFUNCTIONING PART

Check the following.

- Harness connectors E211, M41
- Harness connectors M82, F102
- Joint connector-3
- Harness for open or short between IPDM E/R and mass air flow sensor
- Harness for open or short between mass air flow sensor and ECM

>> Repair open circuit or short to ground or short to power in harness or connectors.

4. CHECK MAF SENSOR GROUND CIRCUIT FOR OPEN AND SHORT

1. Turn ignition switch OFF.
2. Disconnect ECM harness connector.
3. Check harness continuity between MAF sensor terminal 3 and ECM terminal 67. Refer to Wiring Diagram.

Continuity should exist.

4. Also check harness for short to ground and short to power.

OK or NG

- OK >> GO TO 5.
- NG >> Repair open circuit or short to ground or short to power in harness or connectors.

5. CHECK MAF SENSOR INPUT SIGNAL CIRCUIT FOR OPEN AND SHORT

1. Check harness continuity between MAF sensor terminal 1 and ECM terminal 51.
Refer to Wiring Diagram.

Continuity should exist.

2. Also check harness for short to ground and short to power.

OK or NG

OK >> GO TO 6.

NG >> Repair open circuit or short to ground or short to power in harness or connectors.

6. CHECK MASS AIR FLOW SENSOR

Refer to [EC-829, "Component Inspection"](#) .

OK or NG

OK >> GO TO 7.

NG >> Replace mass air flow sensor.

7. CHECK INTERMITTENT INCIDENT

Refer to [EC-784, "TROUBLE DIAGNOSIS FOR INTERMITTENT INCIDENT"](#) .

>> **INSPECTION END**

**Component Inspection
MASS AIR FLOW SENSOR**

ABS00C8A

1. Reconnect all harness connectors disconnected.
2. Start engine and warm it up to normal operating temperature.
3. Check voltage between ECM terminal 51 (Mass air flow sensor signal) and ground.

Condition	Voltage V
Ignition switch ON (Engine stopped.)	Approx. 1.0
Idle (Engine is warmed-up to normal operating temperature.)	1.2 - 1.8
2,500 rpm (Engine is warmed-up to normal operating temperature.)	1.7 - 2.4
Idle to about 4,000 rpm*	1.2 - 1.8 to Approx. 4.0

*: Check for linear voltage rise in response to engine being increased to about 4,000 rpm.

4. If the voltage is out of specification, proceed the following.
 - Turn ignition switch OFF.
 - Disconnect mass air flow sensor harness connector and reconnect it again.
 - Perform steps 2 and 3 again.
5. If NG, remove mass air flow sensor from air duct. Check hot film for damage or dust.
6. If NG, clean or replace mass air flow sensor.

**Removal and Installation
MASS AIR FLOW SENSOR**

ABS00C8B

Refer to [EM-172, "AIR CLEANER AND AIR DUCT"](#) .

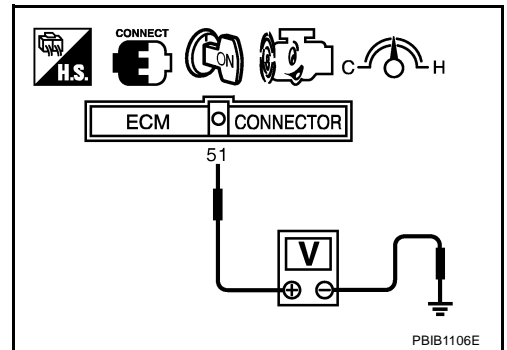

PBIB1106E

DTC P1111, P1136 IVT CONTROL SOLENOID VALVE

PFP:23796

Component Description

ABS00C8C

Intake valve timing control solenoid valve is activated by ON/OFF pulse duty (ratio) signals from the ECM.

The intake valve timing control solenoid valve changes the oil amount and direction of flow through intake valve timing control unit or stops oil flow.

The longer pulse width advances valve angle.

The shorter pulse width retards valve angle.

When ON and OFF pulse widths become equal, the solenoid valve stops oil pressure flow to fix the intake valve angle at the control position.

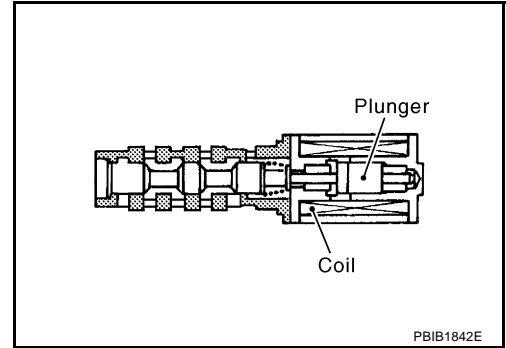

CONSULT-II Reference Value in Data Monitor Mode

ABS00C8D

Specification data are reference values.

MONITOR ITEM	CONDITION		SPECIFICATION
INT/V SOL (B1) INT/V SOL (B2)	<ul style="list-style-type: none"> ● Engine: After warming up ● Air conditioner switch: OFF 	Idle	0% - 2%
	<ul style="list-style-type: none"> ● Shift lever: N ● No load 	2,000 rpm	Approx. 25% - 50%

On Board Diagnosis Logic

ABS00C8E

DTC No.	Trouble diagnosis name	DTC detecting condition	Possible cause
P1111 1111 (Bank 1)	Intake valve timing control solenoid valve circuit	An improper voltage is sent to the ECM through intake valve timing control solenoid valve.	<ul style="list-style-type: none"> ● Harness or connectors (Intake valve timing control solenoid valve circuit is open or shorted.) ● Intake valve timing control solenoid valve
P1136 1136 (Bank 2)			

DTC Confirmation Procedure

ABS00C8F

NOTE:

If DTC Confirmation Procedure has been previously conducted, always turn ignition switch OFF and wait at least 10 seconds before conducting the next test.

WITH CONSULT-II

1. Turn ignition switch ON.
2. Select "DATA MONITOR" mode with CONSULT-II.
3. Start engine and let it idle for 5 seconds.
4. If 1st trip DTC is detected, go to [EC-1074, "Diagnostic Procedure"](#).

DATA MONITOR	
MONITOR	NO DTC
ENG SPEED	XXX rpm

SEF058Y

WITH GST

Following the procedure "WITH CONSULT-II" above.

DTC P1111, P1136 IVT CONTROL SOLENOID VALVE

[VK45DE]

Wiring Diagram BANK 1

ABS00C8G

EC-IVCB1-01

— : DETECTABLE LINE FOR DTC
- - - : NON-DETECTABLE LINE FOR DTC

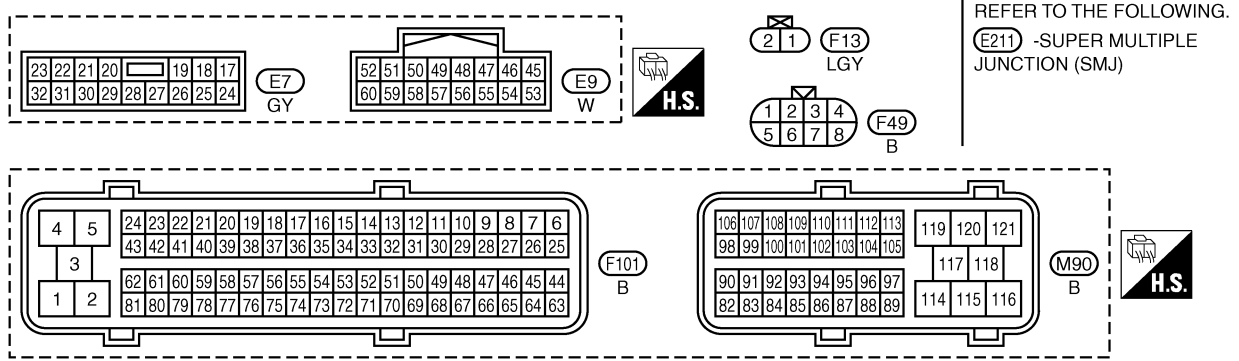
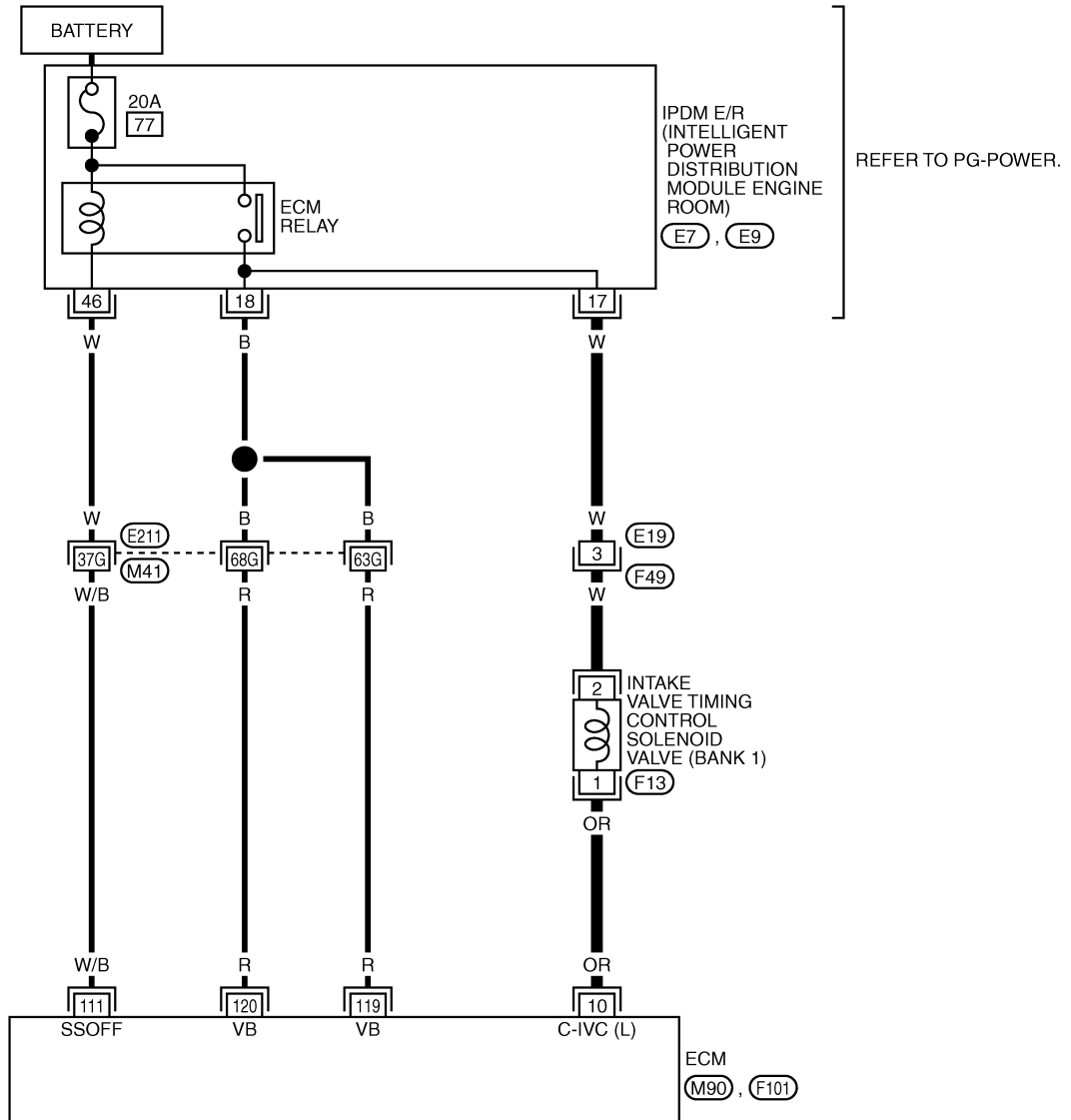

TBWM0219E

DTC P1111, P1136 IVT CONTROL SOLENOID VALVE

[VK45DE]

Specification data are reference values and are measured between each terminal and ground.
Pulse signal is measured by CONSULT-II.

CAUTION:

Do not use ECM ground terminals when measuring input/output voltage. Doing so may result in damage to the ECM's transistor. Use a ground other than ECM terminals, such as the ground.

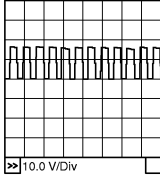
TER-MINAL NO.	WIRE COLOR	ITEM	CONDITION	DATA (DC Voltage)
10	OR	Intake valve timing control solenoid valve (bank 1)	[Engine is running] <ul style="list-style-type: none"> ● Warm-up condition ● Idle speed 	BATTERY VOLTAGE (11 - 14V)
			[Engine is running] <ul style="list-style-type: none"> ● Warm-up condition ● Engine speed is 2,000 rpm 	7 - 12V★ 

PBIB1790E

★: Average voltage for pulse signal (Actual pulse signal can be confirmed by oscilloscope.)

DTC P1111, P1136 IVT CONTROL SOLENOID VALVE

[VK45DE]

BANK 2

EC-IVCB2-01

— : DETECTABLE LINE FOR DTC
 — : NON-DETECTABLE LINE FOR DTC

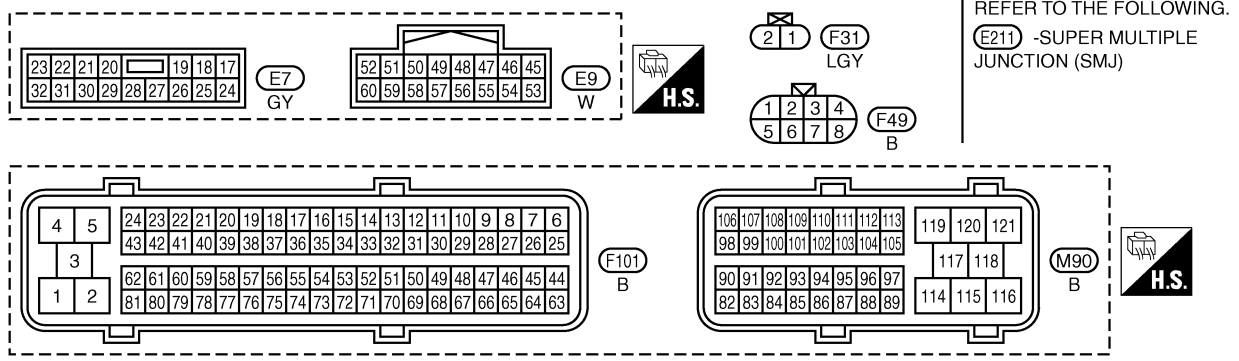
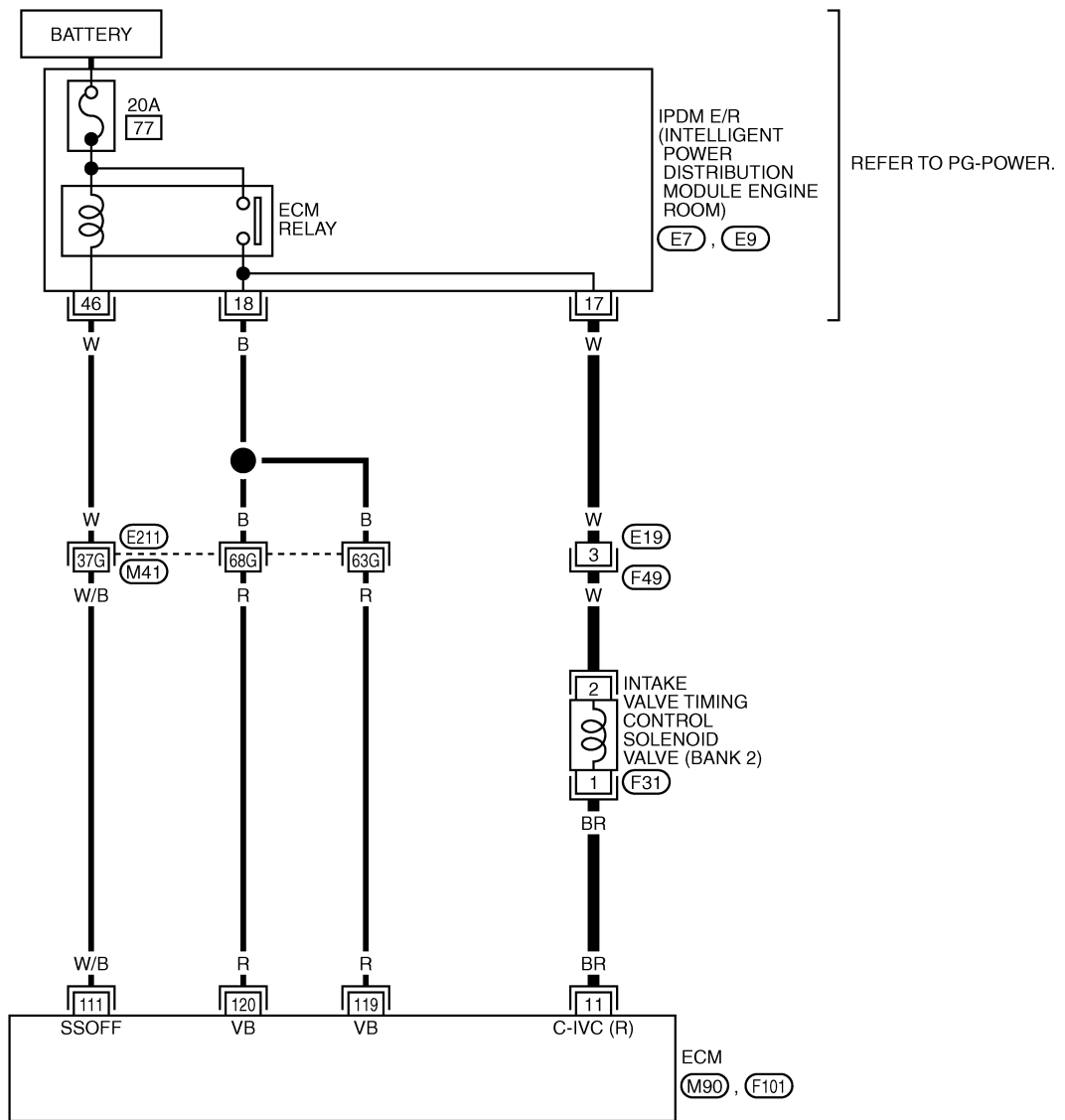

TBWM0220E

DTC P1111, P1136 IVT CONTROL SOLENOID VALVE

[VK45DE]

Specification data are reference values and are measured between each terminal and ground.
Pulse signal is measured by CONSULT-II.

CAUTION:

Do not use ECM ground terminals when measuring input/output voltage. Doing so may result in damage to the ECM's transistor. Use a ground other than ECM terminals, such as the ground.

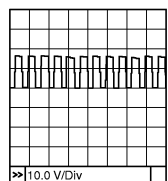
TER-MINAL NO.	WIRE COLOR	ITEM	CONDITION	DATA (DC Voltage)
11	BR	Intake valve timing control solenoid valve (bank 2)	[Engine is running] ● Warm-up condition ● Idle speed	BATTERY VOLTAGE (11 - 14V)
			[Engine is running] ● Warm-up condition ● Engine speed is 2,000 rpm	7 - 12V★ 

★: Average voltage for pulse signal (Actual pulse signal can be confirmed by oscilloscope.)

Diagnostic Procedure

ABS00C8H

1. CHECK INTAKE VALVE TIMING CONTROL SOLENOID VALVE POWER SUPPLY CIRCUIT

1. Turn ignition switch OFF.
2. Disconnect intake valve timing control solenoid valve harness connector.

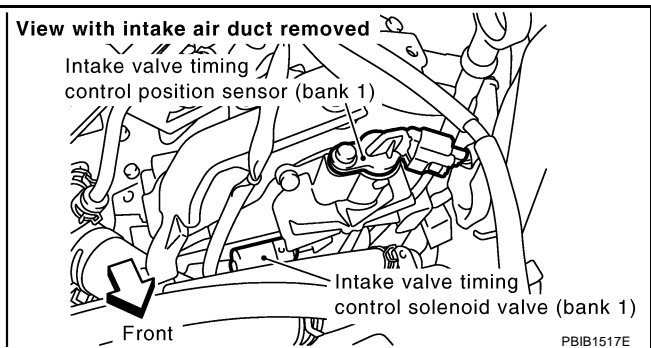
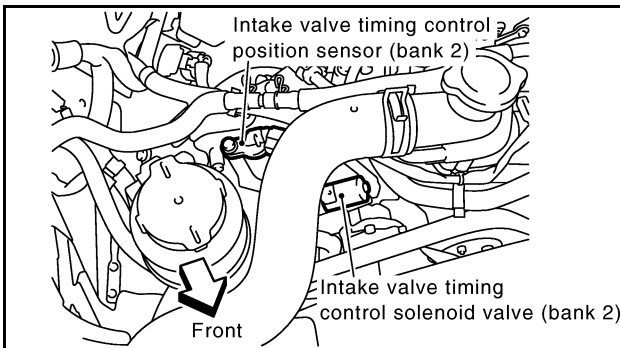

3. Turn ignition switch ON.
4. Check voltage between intake valve timing control solenoid valve terminal 2 and ground with CONSULT-II or tester.

Voltage: Battery voltage

OK or NG

- OK >> GO TO 3.
- NG >> GO TO 2.

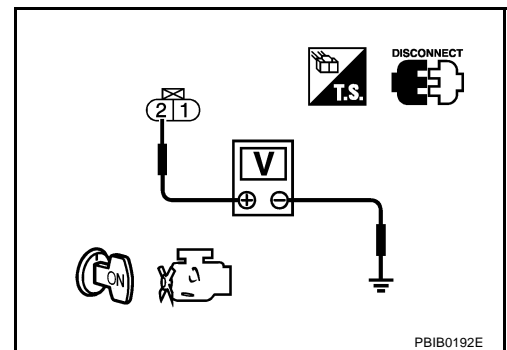

2. DETECT MALFUNCTIONING PART

Check the following.

- Harness connectors E19, F49
- IPDM E/R harness connector E7
- Harness for open or short between intake valve timing control solenoid valve and IPDM E/R

>> Repair open circuit or short to ground or short to power in harness or connectors.

3. CHECK INTAKE VALVE TIMING CONTROL SOLENOID VALVE OUTPUT SIGNAL CIRCUIT FOR OPEN AND SHORT

1. Turn ignition switch OFF.
2. Disconnect ECM harness connector.
3. Check harness continuity between ECM terminal 10 and intake valve timing control solenoid valve (bank 1) terminal 1 or ECM terminal 11 and intake valve timing control solenoid valve (bank 2) terminal 1. Refer to Wiring Diagram.

Continuity should exist.

4. Also check harness for short to ground and short to power.

OK or NG

OK >> GO TO 4.

NG >> Repair open circuit or short to ground or short to power in harness or connectors.

4. CHECK INTAKE VALVE TIMING CONTROL SOLENOID VALVE

Refer to [EC-1076, "Component Inspection"](#) .

OK or NG

OK >> GO TO 5.

NG >> Replace intake valve timing control solenoid valve.

5. CHECK INTERMITTENT INCIDENT

Refer to [EC-784, "TROUBLE DIAGNOSIS FOR INTERMITTENT INCIDENT"](#) .

>> **INSPECTION END**

Component Inspection

INTAKE VALVE TIMING CONTROL SOLENOID VALVE

1. Disconnect intake valve timing control solenoid valve harness connector.
2. Check resistance between intake valve timing control solenoid valve terminals as follows.

Terminals	Resistance
1 and 2	7.0 - 7.5Ω at 20°C (68°F)
1 or 2 and ground	∞Ω (Continuity should not exist)

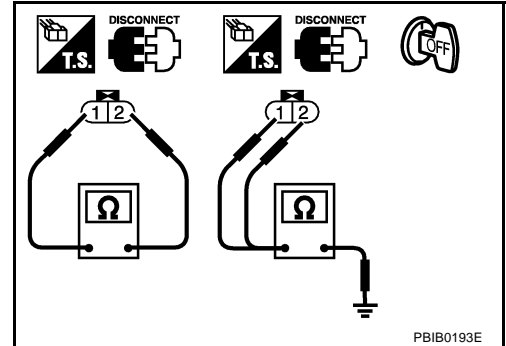

Removal and Installation

INTAKE VALVE TIMING CONTROL SOLENOID VALVE

Refer to [EM-196, "TIMING CHAIN"](#) .

DTC P1121 ELECTRIC THROTTLE CONTROL ACTUATOR

PF16119

Component Description

ABS00C8K

Electric throttle control actuator consists of throttle control motor, throttle position sensor, etc. The throttle control motor is operated by the ECM and it opens and closes the throttle valve. The throttle position sensor detects the throttle valve position, and the opening and closing speed of the throttle valve and feeds the voltage signals to the ECM. The ECM judges the current opening angle of the throttle valve from these signals and the ECM controls the throttle control motor to make the throttle valve opening angle properly in response to driving condition.

On Board Diagnosis Logic

ABS00C8L

This self-diagnosis has one trip detection logic.

DTC No.	Trouble diagnosis name	DTC detecting condition		Possible cause
P1121 1121	Electric throttle control actuator	A)	Electric throttle control actuator does not function properly due to the return spring malfunction.	● Electric throttle control actuator
		B)	Throttle valve opening angle in fail-safe mode is not in specified range.	
		C)	ECM detect the throttle valve is stuck open.	

FAIL-SAFE MODE

When the malfunction is detected, ECM enters fail-safe mode and the MIL lights up.

Detected items	Engine operating condition in fail-safe mode
Malfunction A	The ECM controls the electric throttle actuator by regulating the throttle opening around the idle position. The engine speed will not rise more than 2,000 rpm.
Malfunction B	ECM controls the electric throttle control actuator by regulating the throttle opening to 20 degrees or less.
Malfunction C	While the vehicle is driving, it slows down gradually by fuel cut. After the vehicle stops, the engine stalls. The engine can restart in N or P position, and engine speed will not exceed 1,000 rpm or more.

DTC Confirmation Procedure

ABS00C8M

NOTE:

- Perform **PROCEDURE FOR MALFUNCTION A AND B** first. If the DTC cannot be confirmed, perform **PROCEDURE FOR MALFUNCTION C**.
- If DTC Confirmation Procedure has been previously conducted, always turn ignition switch OFF and wait at least 10 seconds before conducting the next test.

PROCEDURE FOR MALFUNCTION A AND B

With CONSULT-II

1. Turn ignition switch ON and wait at least 1 second.
2. Select "DATA MONITOR" mode with CONSULT-II.
3. Shift selector lever to D position and wait at least 3 seconds.
4. Shift selector lever to P position.
5. Turn ignition switch OFF and wait at least 10 seconds.
6. Turn ignition switch ON and wait at least 1 second.
7. Shift selector lever to D position and wait at least 3 seconds.
8. Shift selector lever to P position.
9. Turn ignition switch OFF, wait at least 10 seconds, and then turn ON.
10. If DTC is detected, go to [EC-1078, "Diagnostic Procedure"](#).

DATA MONITOR	
MONITOR	NO DTC
ENG SPEED	XXX rpm

SEF058Y

With GST

Follow the procedure "With CONSULT-II" above.

PROCEDURE FOR MALFUNCTION C

① With CONSULT-II

1. Turn ignition switch ON and wait at least 1 second.
2. Select "DATA MONITOR" mode with CONSULT-II.
3. Shift selector lever to D position and wait at least 3 seconds.
4. Shift selector lever to N, P position.
5. Start engine and let it idle for 3 seconds.
6. If DTC is detected, go to [EC-1078, "Diagnostic Procedure"](#) .

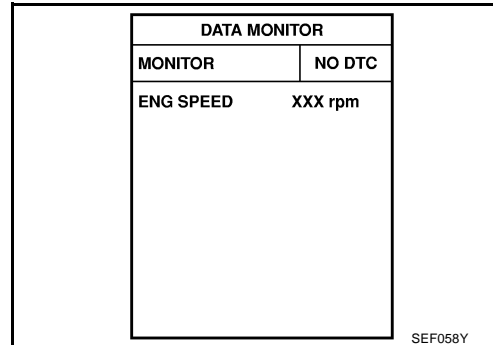

② With GST

Follow the procedure "With CONSULT-II" above.

Diagnostic Procedure

ABS00C8N

1. CHECK ELECTRIC THROTTLE CONTROL ACTUATOR VISUALLY

1. Remove the intake air duct.
2. Check if a foreign matter is caught between the throttle valve and the housing.

OK or NG

- OK >> GO TO 2.
 NG >> Remove the foreign matter and clean the electric throttle control actuator inside.

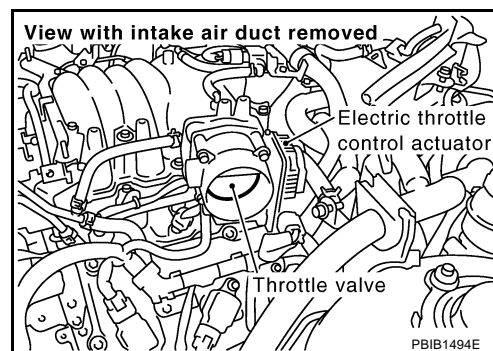

2. REPLACE ELECTRIC THROTTLE CONTROL ACTUATOR

1. Replace the electric throttle control actuator.
2. Perform [EC-698, "Throttle Valve Closed Position Learning"](#) .
3. Perform [EC-698, "Idle Air Volume Learning"](#) .

>> INSPECTION END

DTC P1122 ELECTRIC THROTTLE CONTROL FUNCTION

PFP:16119

Description

ABS00C80

NOTE:

If DTC P1122 is displayed with DTC P1121 or 1126, first perform the trouble diagnosis for DTC P1121 or P1126. Refer to [EC-1077](#) or [EC-1085](#).

Electric throttle control actuator consists of throttle control motor, throttle position sensor, etc.

The throttle control motor is operated by the ECM and it opens and closes the throttle valve.

The current opening angle of the throttle valve is detected by the throttle position sensor and it provides feedback to the ECM to control the throttle control motor to make the throttle valve opening angle properly in response to driving condition.

On Board Diagnosis Logic

ABS00C8P

This self-diagnosis has the one trip detection logic.

DTC No.	Trouble diagnosis name	DTC detecting condition	Possible cause
P1122 1122	Electric throttle control performance problem	Electric throttle control function does not operate properly.	<ul style="list-style-type: none"> ● Harness or connectors (Throttle control motor circuit is open or shorted) ● Electric throttle control actuator

FAIL-SAFE MODE

When the malfunction is detected, ECM enters fail-safe mode and the MIL lights up.

Engine operating condition in fail-safe mode

ECM stops the electric throttle control actuator control, throttle valve is maintained at a fixed opening (approx. 5 degrees) by the return spring.

DTC Confirmation Procedure

ABS00C8Q

NOTE:

If DTC Confirmation Procedure has been previously conducted, always turn ignition switch OFF and wait at least 10 seconds before conducting the next test.

TESTING CONDITION:

Before performing the following procedure, confirm that battery voltage is more than 11V when engine is running.

WITH CONSULT-II

1. Turn ignition switch ON and wait at least 2 seconds.
2. Select "DATA MONITOR" mode with CONSULT-II.
3. Start engine and let it idle for 5 seconds.
4. If DTC is detected, go to [EC-1081, "Diagnostic Procedure"](#).

DATA MONITOR	
MONITOR	NO DTC
ENG SPEED	XXX rpm

SEF058Y

WITH GST

Follow the procedure "WITH CONSULT-II" above.

DTC P1122 ELECTRIC THROTTLE CONTROL FUNCTION

[VK45DE]

ABS00C8R

Wiring Diagram

EC-ETC1-01

— : DETECTABLE LINE FOR DTC
 — : NON-DETECTABLE LINE FOR DTC

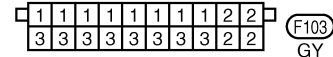
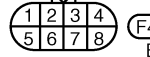
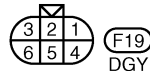
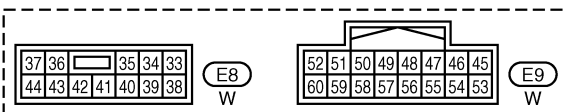
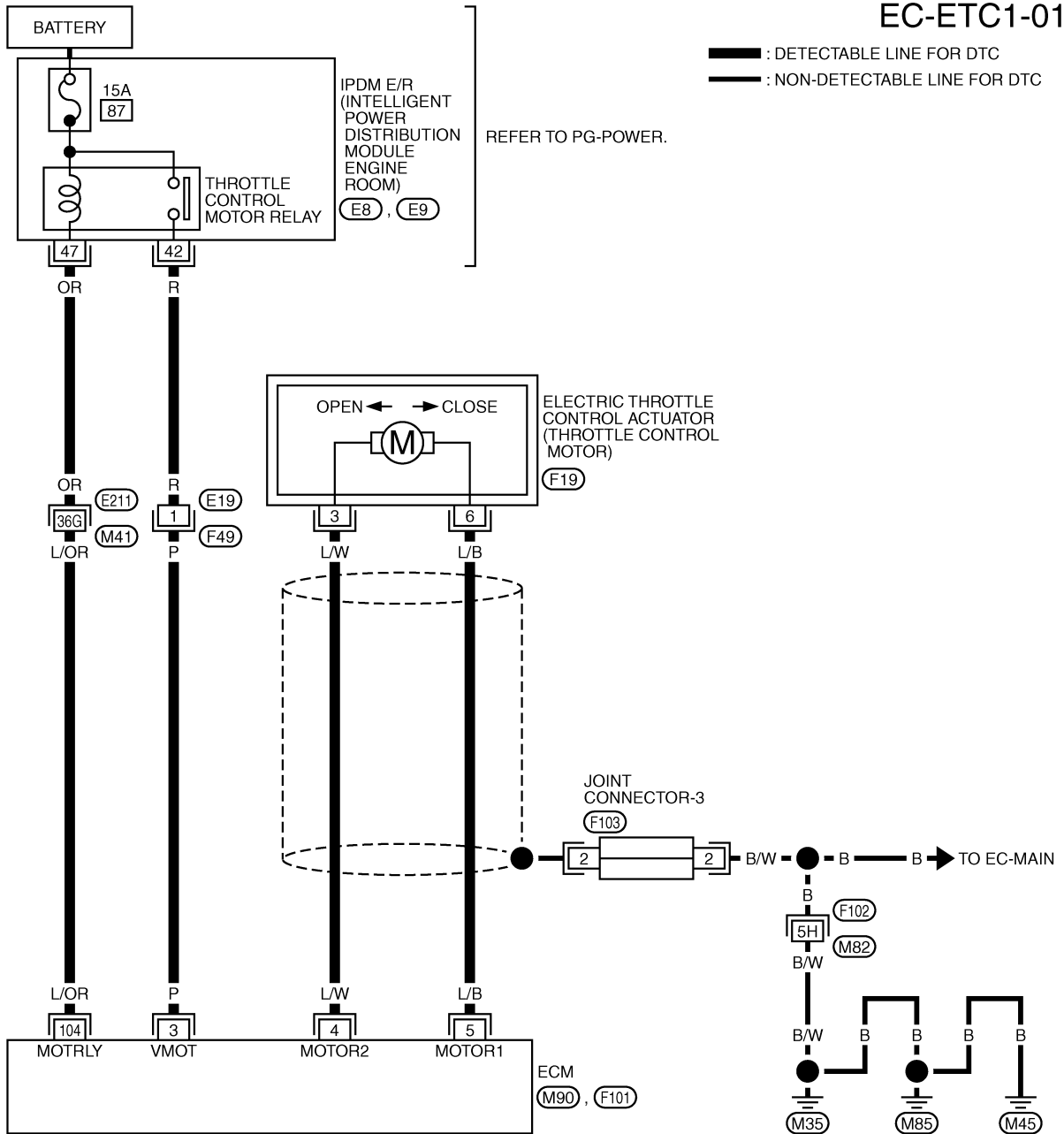

REFER TO THE FOLLOWING.
 (E211), (F102) -SUPER MULTIPLE JUNCTION (SMJ)

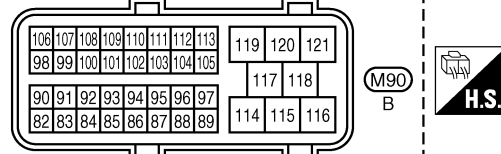
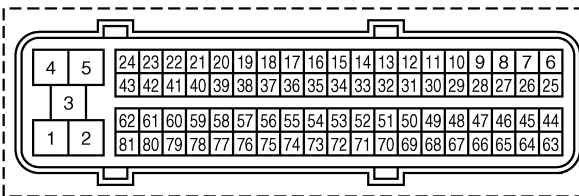

TBWM0251E

DTC P1122 ELECTRIC THROTTLE CONTROL FUNCTION

[VK45DE]

Specification data are reference values and are measured between each terminal and ground.
Pulse signal is measured by CONSULT-II.

CAUTION:

Do not use ECM ground terminals when measuring input/output voltage. Doing so may result in damage to the ECM's transistor. Use a ground other than ECM terminals, such as the ground.

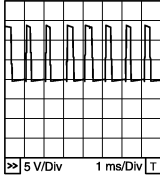
TER-MINAL NO.	WIRE COLOR	ITEM	CONDITION	DATA (DC Voltage)
3	P	Throttle control motor relay power supply	[Ignition switch: ON]	BATTERY VOLTAGE (11 - 14V)
4	L/W	Throttle control motor (Close)	[Ignition switch: ON] ● Engine stopped ● Shift lever: D ● Accelerator pedal is released	0 - 14V★  PBIB1104E
5	L/B	Throttle control motor (Open)	[Ignition switch: ON] ● Engine stopped ● Shift lever: D ● Accelerator pedal is fully depressed	0 - 14V★  PBIB1105E
104	L/OR	Throttle control motor relay	[Ignition switch: OFF]	BATTERY VOLTAGE (11 - 14V)
			[Ignition switch: ON]	0 - 1.0V

Diagnostic Procedure

ABS00C8S

1. CHECK GROUND CONNECTIONS

1. Turn ignition switch OFF.
2. Loosen and retighten three ground screws on the body.
Refer to [EC-791, "Ground Inspection"](#) .

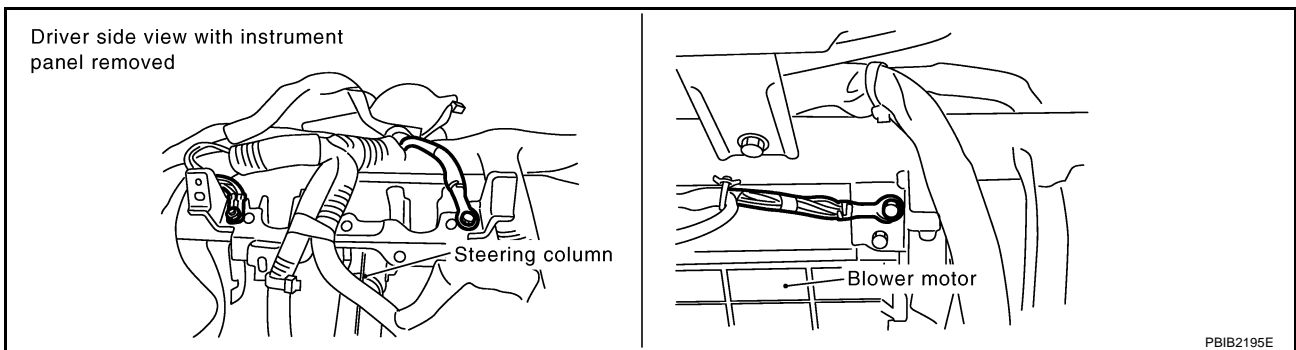

OK or NG

- OK >> GO TO 2.
- NG >> Repair or replace ground connections.

2. CHECK THROTTLE CONTROL MOTOR RELAY INPUT SIGNAL CIRCUIT-I

1. Check voltage between ECM terminal 3 and ground under the following conditions with CONSULT-II or tester.

Ignition switch	Voltage
OFF	Approximately 0V
ON	Battery voltage (11 - 14V)

OK or NG

- OK >> GO TO 10.
- NG >> GO TO 3.

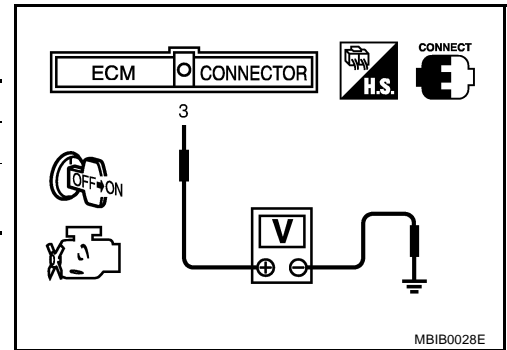

3. CHECK THROTTLE CONTROL MOTOR RELAY INPUT SIGNAL CIRCUIT-II

1. Turn ignition switch OFF.
2. Disconnect ECM harness connector.
3. Disconnect IPDM E/R harness connector E8.
4. Check harness continuity between ECM terminal 3 and IPDM E/R terminal 42. Refer to Wiring Diagram.

Continuity should exist.

5. Also check harness for short to ground and short to power.

OK or NG

- OK >> GO TO 5.
- NG >> GO TO 4.

4. DETECT MALFUNCTIONING PART

Check the following.

- Harness connectors E19, F49
- Harness for open or short between ECM and IPDM E/R

>> Repair open circuit or short to ground or short to power in harness or connectors.

5. CHECK THROTTLE CONTROL MOTOR RELAY POWER SUPPLY CIRCUIT-I

1. Reconnect all harness connectors disconnected.
2. Turn ignition switch OFF.
3. Check voltage between ECM terminal 104 and ground with CONSULT-II or tester.

Voltage: Battery voltage

OK or NG

- OK >> GO TO 9.
- NG >> GO TO 6.

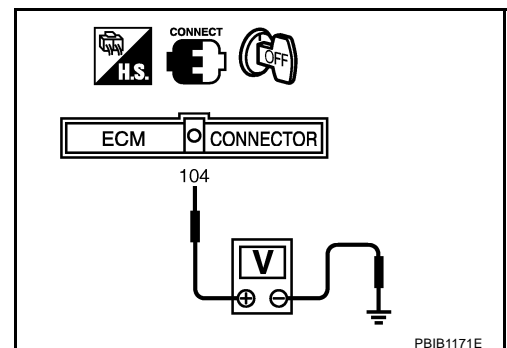

6. CHECK THROTTLE CONTROL MOTOR RELAY POWER SUPPLY CIRCUIT-II

1. Disconnect ECM harness connector.
2. Disconnect IPDM E/R harness connector E9.
3. Check harness continuity between ECM terminal 104 and IPDM E/R terminal 47.
Refer to Wiring Diagram.

Continuity should exist.

4. Also check harness for short to ground and short to power.

OK or NG

- OK >> GO TO 8.
- NG >> GO TO 7.

7. DETECT MALFUNCTIONING PART

Check the following.

- Harness connectors E211, M41
- Harness for open or short between ECM and IPDM E/R

>> Repair open circuit or short to ground or short to power in harness or connectors.

8. CHECK FUSE

1. Disconnect 15A fuse.
2. Check 15A fuse for blown.

OK or NG

- OK >> GO TO 9.
- NG >> Replace 15A fuse.

9. CHECK INTERMITTENT INCIDENT

Refer to [EC-784. "TROUBLE DIAGNOSIS FOR INTERMITTENT INCIDENT"](#) .

OK or NG

- OK >> Replace IPDM E/R. Refer to [PG-18. "IPDM E/R \(INTELLIGENT POWER DISTRIBUTION MODULE ENGINE ROOM\)"](#) .
- NG >> Repair or replace harness or connectors.

10. CHECK THROTTLE CONTROL MOTOR OUTPUT SIGNAL CIRCUIT FOR OPEN OR SHORT

1. Turn ignition switch OFF.
2. Disconnect electric throttle control actuator harness connector.
3. Disconnect ECM harness connector.
4. Check harness continuity between the following terminals.
Refer to Wiring Diagram.

Electric throttle control actuator terminal	ECM terminal	Continuity
3	5	Should not exist
	4	Should exist
6	5	Should exist
	4	Should not exist

5. Also check harness for short to ground and short to power.

OK or NG

- OK >> GO TO 11.
- NG >> Repair or replace.

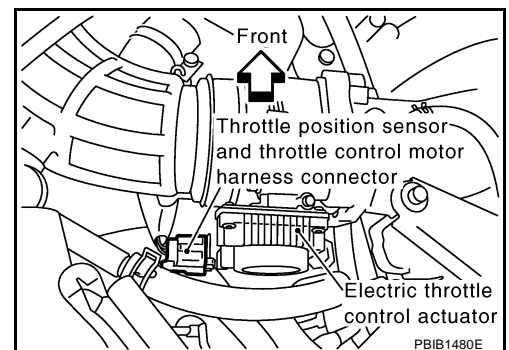

11. CHECK ELECTRIC THROTTLE CONTROL ACTUATOR VISUALLY

1. Remove the intake air duct.
2. Check if foreign matter is caught between the throttle valve and the housing.

OK or NG

- OK >> GO TO 12.
 NG >> Remove the foreign matter and clean the electric throttle control actuator inside.

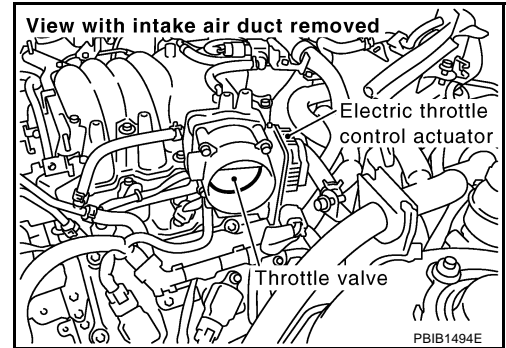

12. CHECK THROTTLE CONTROL MOTOR

Refer to [EC-1084, "Component Inspection"](#) .

OK or NG

- OK >> GO TO 13.
 NG >> GO TO 14.

13. CHECK INTERMITTENT INCIDENT

Refer to [EC-784, "TROUBLE DIAGNOSIS FOR INTERMITTENT INCIDENT"](#) .

OK or NG

- OK >> GO TO 14.
 NG >> Repair or replace harness or connectors.

14. REPLACE ELECTRIC THROTTLE CONTROL ACTUATOR

1. Replace the electric throttle control actuator.
2. Perform [EC-698, "Throttle Valve Closed Position Learning"](#) .
3. Perform [EC-698, "Idle Air Volume Learning"](#) .

>> INSPECTION END

Component Inspection THROTTLE CONTROL MOTOR

ABS00C8T

1. Disconnect electric throttle control actuator harness connector.
2. Check resistance between terminals 3 and 6.

Resistance: Approximately 1 - 15 Ω [at 25 °C (77°F)]

3. If NG, replace electric throttle control actuator and go to next step.
4. Perform [EC-698, "Throttle Valve Closed Position Learning"](#) .
5. Perform [EC-698, "Idle Air Volume Learning"](#) .

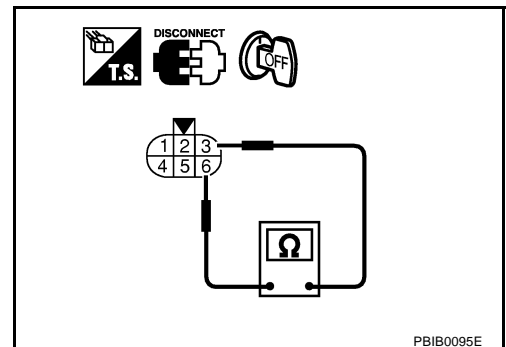

Removal and Installation ELECTRIC THROTTLE CONTROL ACTUATOR

ABS00C8U

Refer to [EM-174, "INTAKE MANIFOLD"](#) .

DTC P1124, P1126 THROTTLE CONTROL MOTOR RELAY

[VK45DE]

DTC P1124, P1126 THROTTLE CONTROL MOTOR RELAY

PFP:16119

Component Description

ABS00C8V

Power supply for the throttle control motor is provided to the ECM via throttle control motor relay. The throttle control motor relay is ON/OFF controlled by the ECM. When the ignition switch is turned ON, the ECM sends an ON signal to throttle control motor relay and battery voltage is provided to the ECM. When the ignition switch is turned OFF, the ECM sends an OFF signal to throttle control motor relay and battery voltage is not provided to the ECM.

CONSULT-II Reference Value in Data Monitor Mode

ABS00C8W

Specification data are reference values.

MONITOR ITEM	CONDITION	SPECIFICATION
THRTL RELAY	● Ignition switch: ON	ON

On Board Diagnosis Logic

ABS00C8X

These self-diagnoses have the one trip detection logic.

DTC No.	Trouble diagnosis name	DTC detecting condition	Possible cause
P1124 1124	Throttle control motor relay circuit short	ECM detect the throttle control motor relay is stuck ON.	<ul style="list-style-type: none">● Harness or connectors (Throttle control motor relay circuit is shorted)● Throttle control motor relay
P1126 1126	Throttle control motor relay circuit open	ECM detects a voltage of power source for throttle control motor is excessively low.	<ul style="list-style-type: none">● Harness or connectors (Throttle control motor relay circuit is open)● Throttle control motor relay

FAIL-SAFE MODE

When the malfunction is detected, ECM enters fail-safe mode and the MIL lights up.

Engine operating condition in fail-safe mode

ECM stops the electric throttle control actuator control, throttle valve is maintained at a fixed opening (approx. 5 degrees) by the return spring.

DTC Confirmation Procedure

ABS00C8Y

NOTE:

If DTC Confirmation Procedure has been previously conducted, always turn ignition switch OFF and wait at least 10 seconds before conducting the next test.

PROCEDURE FOR DTC P1124

TESTING CONDITION:

Before performing the following procedure, confirm that battery voltage is more than 8V.

④ With CONSULT-II

1. Turn ignition switch ON and wait at least 1 second.
2. Select "DATA MONITOR" mode with CONSULT-II.
3. If DTC is detected, go to [EC-1088, "Diagnostic Procedure"](#).

DATA MONITOR	
MONITOR	NO DTC
ENG SPEED	XXX rpm

SEF058Y

 **With GST**

Follow the procedure "With CONSULT-II" above.

PROCEDURE FOR DTC P1126 **With CONSULT-II**

1. Turn ignition switch ON and wait at least 2 seconds.
2. Select "DATA MONITOR" mode with CONSULT-II.
3. Start engine and let it idle for 5 seconds.
4. If DTC is detected, go to [EC-1088, "Diagnostic Procedure"](#) .

DATA MONITOR	
MONITOR	NO DTC
ENG SPEED	XXX rpm

SEF058Y

 **With GST**

Follow the procedure "With CONSULT-II" above.

DTC P1124, P1126 THROTTLE CONTROL MOTOR RELAY

[VK45DE]

ABS00C8Z

Wiring Diagram

EC-ETC2-01

— : DETECTABLE LINE FOR DTC
 — : NON-DETECTABLE LINE FOR DTC

A
 EC
 C
 D
 E
 F
 G
 H
 I
 J
 K
 L
 M

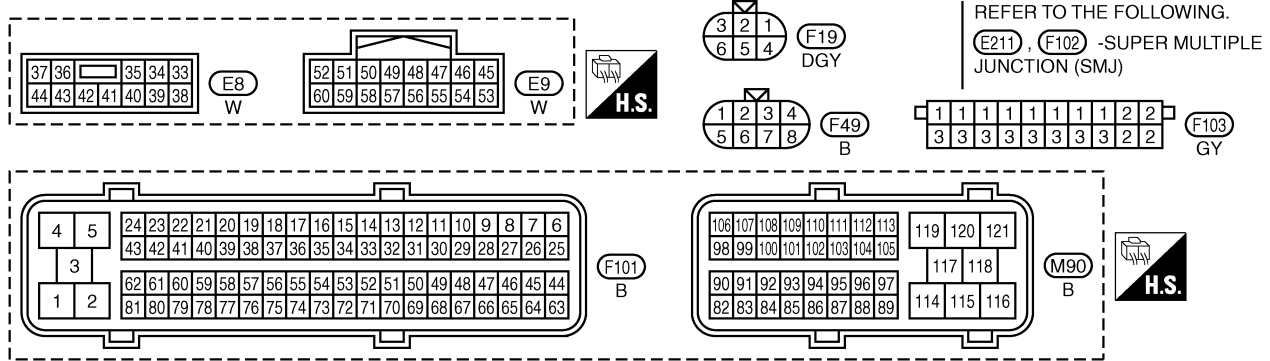
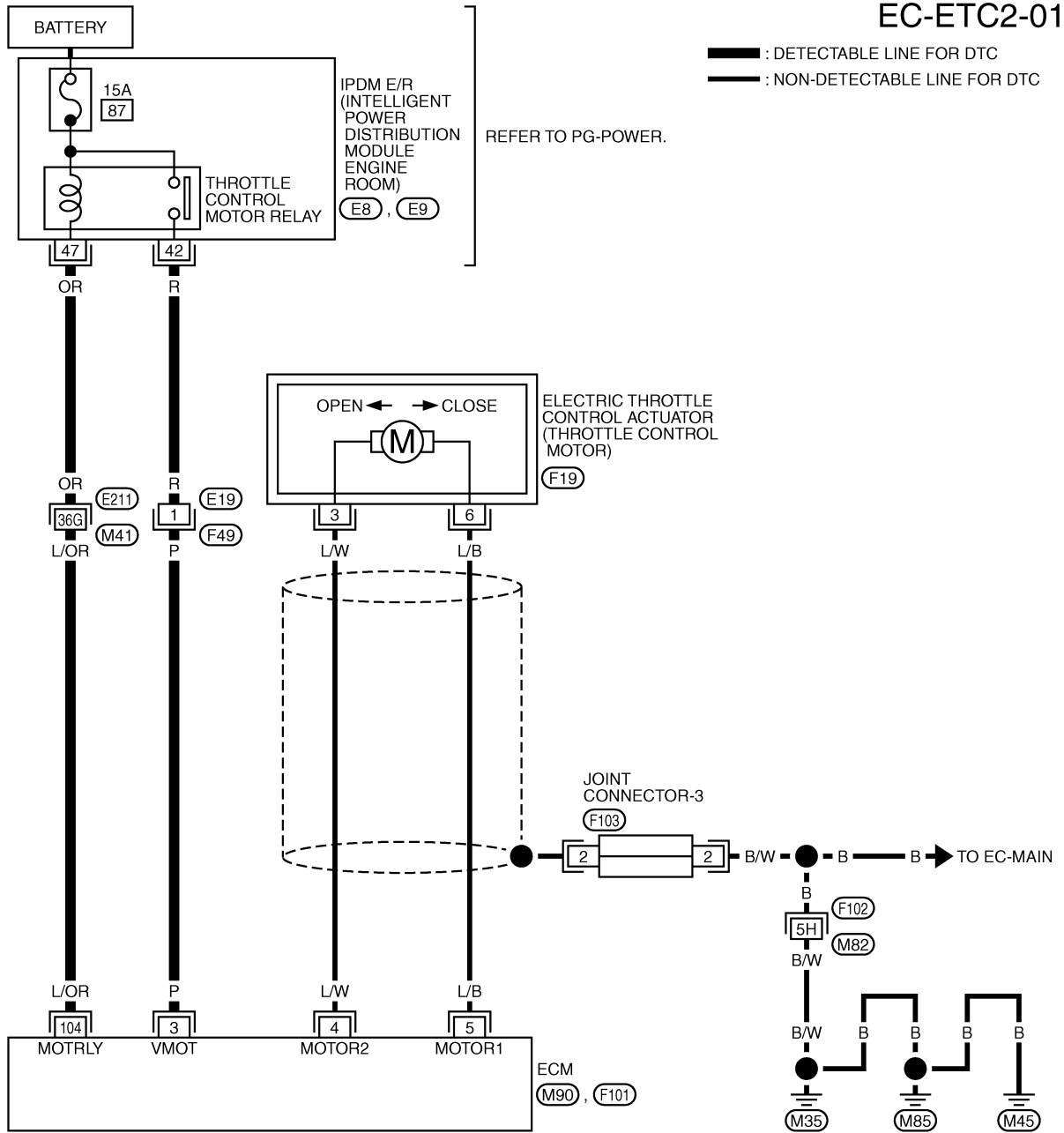

TBWM0252E

DTC P1124, P1126 THROTTLE CONTROL MOTOR RELAY

[VK45DE]

Specification data are reference values and are measured between each terminal and ground.

CAUTION:

Do not use ECM ground terminals when measuring input/output voltage. Doing so may result in damage to the ECM's transistor. Use a ground other than ECM terminals, such as the ground.

TER-MINAL NO.	WIRE COLOR	ITEM	CONDITION	DATA (DC Voltage)
3	P	Throttle control motor relay power supply	[Ignition switch: ON]	BATTERY VOLTAGE (11 - 14V)
104	L/OR	Throttle control motor relay	[Ignition switch: OFF]	BATTERY VOLTAGE (11 - 14V)
			[Ignition switch: ON]	0 - 1.0V

Diagnostic Procedure

ABS00C90

1. CHECK THROTTLE CONTROL MOTOR RELAY POWER SUPPLY CIRCUIT-I

1. Turn ignition switch OFF.
2. Check voltage between ECM terminal 104 and ground with CONSULT-II or tester.

Voltage: Battery voltage

OK or NG

- OK >> GO TO 5.
NG >> GO TO 2.

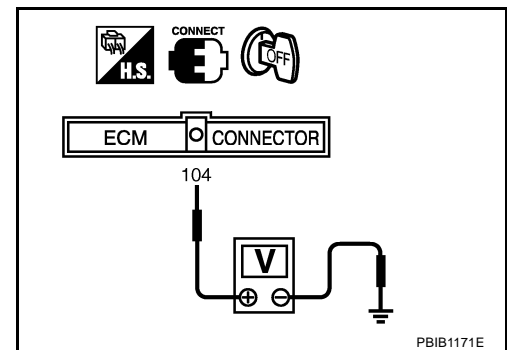

2. CHECK THROTTLE CONTROL MOTOR RELAY POWER SUPPLY CIRCUIT-II

1. Disconnect ECM harness connector.
2. Disconnect IPDM E/R harness connector E9.
3. Check continuity between ECM terminal 104 and IPDM E/R terminal 47. Refer to Wiring Diagram.

Continuity should exist.

4. Also check harness for short to ground and short to power.

OK or NG

- OK >> GO TO 4.
NG >> GO TO 3.

3. DETECT MALFUNCTIONING PART

Check the following.

- Harness connectors E211, M41
- Harness for open or short between ECM and IPDM E/R

>> Repair open circuit or short to ground or short to power in harness or connectors.

4. CHECK FUSE

1. Disconnect 15A fuse.
2. Check 15A fuse for blown.

OK or NG

- OK >> GO TO 8.
 NG >> Replace 15A fuse.

5. CHECK THROTTLE CONTROL MOTOR RELAY INPUT SIGNAL CIRCUIT-I

1. Check voltage between ECM terminal 3 and ground under the following conditions with CONSULT-II or tester.

Ignition switch	Voltage
OFF	Approximately 0V
ON	Battery voltage (11 - 14V)

OK or NG

- OK >> GO TO 8.
 NG >> GO TO 6.

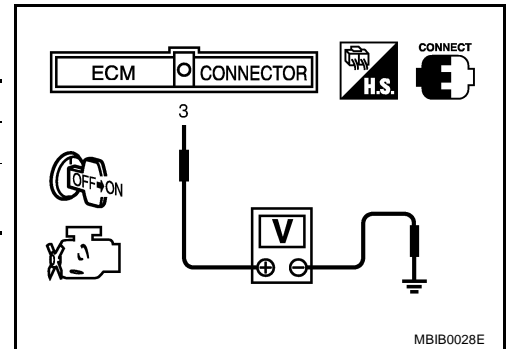

6. CHECK THROTTLE CONTROL MOTOR RELAY INPUT SIGNAL CIRCUIT-II

1. Turn ignition switch OFF.
2. Disconnect ECM harness connector.
3. Disconnect IPDM E/R harness connector E8.
4. Check continuity between ECM terminal 3 and IPDM E/R terminal 42. Refer to Wiring Diagram.

Continuity should exist.

5. Also check harness for short to ground and short to power.

OK or NG

- OK >> GO TO 8.
 NG >> GO TO 7.

7. DETECT MALFUNCTIONING PART

Check the following.

- Harness connectors E19, F49
- Harness for open or short between ECM and IPDM E/R

>> Repair open circuit or short to ground or short to power in harness or connectors.

8. CHECK INTERMITTENT INCIDENT

Refer to [EC-784, "TROUBLE DIAGNOSIS FOR INTERMITTENT INCIDENT"](#) .

OK or NG

- OK >> Replace IPDM E/R. Refer to [PG-18, "IPDM E/R \(INTELLIGENT POWER DISTRIBUTION MODULE ENGINE ROOM\)"](#) .
 NG >> Repair or replace harness or connectors.

DTC P1128 THROTTLE CONTROL MOTOR

PFP:16119

Component Description

ABS00C91

The throttle control motor is operated by the ECM and it opens and closes the throttle valve. The current opening angle of the throttle valve is detected by the throttle position sensor and it provides feedback to the ECM to control the throttle control motor to make the throttle valve opening angle properly in response to driving condition.

On Board Diagnosis Logic

ABS00C92

This self-diagnosis has the one trip detection logic.

DTC No.	Trouble diagnosis name	DTC detecting condition	Possible cause
P1128 1128	Throttle control motor circuit short	ECM detects short in both circuits between ECM and throttle control motor.	<ul style="list-style-type: none"> ● Harness or connectors (Throttle control motor circuit is shorted.) ● Electric throttle control actuator (Throttle control motor)

FAIL-SAFE MODE

When the malfunction is detected, the ECM enters fail-safe mode and the MIL lights up.

Engine operating condition in fail-safe mode

ECM stops the electric throttle control actuator control, throttle valve is maintained at a fixed opening (approx. 5 degrees) by the return spring.

DTC Confirmation Procedure

ABS00C93

NOTE:

If DTC Confirmation Procedure has been previously conducted, always turn ignition switch OFF and wait at least 10 seconds before conducting the next test.

WITH CONSULT-II

1. Turn ignition switch ON and wait at least 2 seconds.
2. Select "DATA MONITOR" mode with CONSULT-II.
3. Start engine and let it idle for 5 seconds.
4. If DTC is detected, go to [EC-1092, "Diagnostic Procedure"](#) .

DATA MONITOR	
MONITOR	NO DTC
ENG SPEED	XXX rpm

SEF058Y

WITH GST

Follow the procedure "WITH CONSULT-II" above.

DTC P1128 THROTTLE CONTROL MOTOR

[VK45DE]

Wiring Diagram

ABS00C94

A
EC
C
D
E
F
G
H
I
J
K
L
M

EC-ETC3-01

— : DETECTABLE LINE FOR DTC
— : NON-DETECTABLE LINE FOR DTC

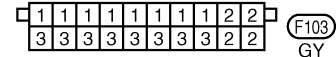
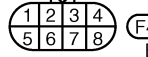
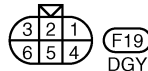
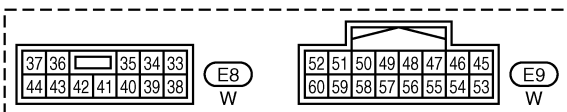
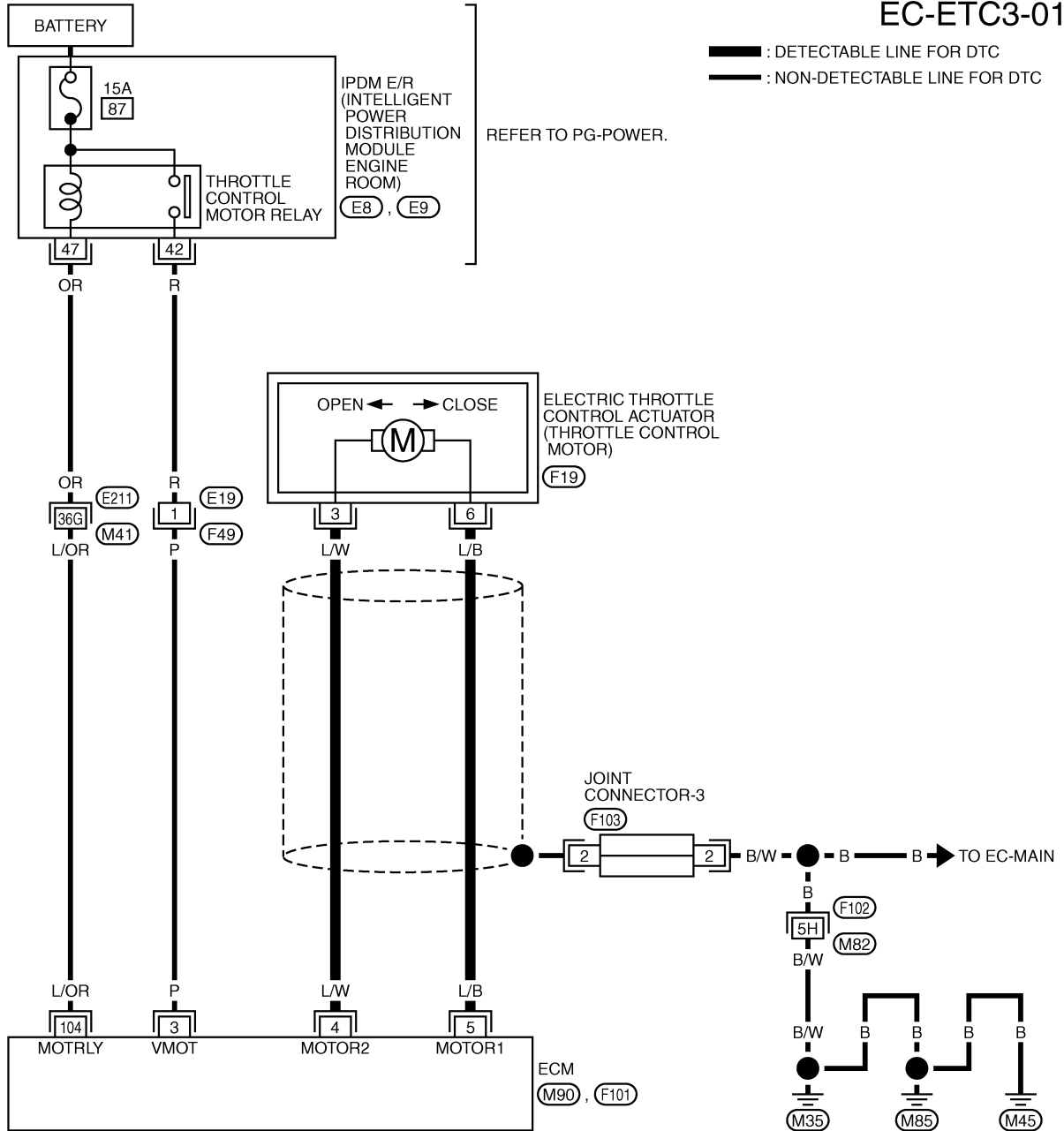

REFER TO THE FOLLOWING.
(E21), (F102) -SUPER MULTIPLE JUNCTION (SMJ)

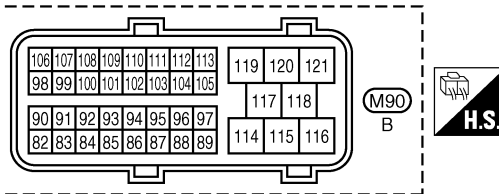
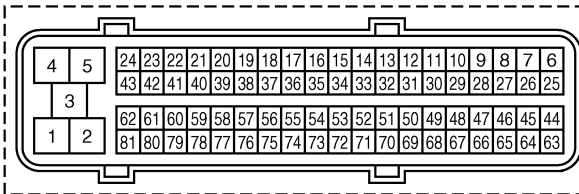

TBWM0253E

DTC P1128 THROTTLE CONTROL MOTOR

[VK45DE]

Specification data are reference values and are measured between each terminal and ground.
Pulse signal is measured by CONSULT-II.

CAUTION:

Do not use ECM ground terminals when measuring input/output voltage. Doing so may result in damage to the ECM's transistor. Use a ground other than ECM terminals, such as the ground.

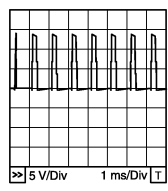
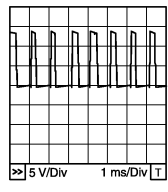
TER-MINAL NO.	WIRE COLOR	ITEM	CONDITION	DATA (DC Voltage)
4	L/W	Throttle control motor (Close)	<p>[Ignition switch: ON]</p> <ul style="list-style-type: none"> ● Engine stopped ● Shift lever: D ● Accelerator pedal is released 	<p>0 - 14V★</p>  <p>PBIB1104E</p>
5	L/B	Throttle control motor (Open)	<p>[Ignition switch: ON]</p> <ul style="list-style-type: none"> ● Engine stopped ● Shift lever: D ● Accelerator pedal is fully depressed 	<p>0 - 14V★</p>  <p>PBIB1105E</p>

★: Average voltage for pulse signal (Actual pulse signal can be confirmed by oscilloscope.)

Diagnostic Procedure

ABS00C95

1. CHECK GROUND CONNECTIONS

1. Turn ignition switch OFF.
2. Loosen and retighten three ground screws on the body.
Refer to [EC-791, "Ground Inspection"](#).

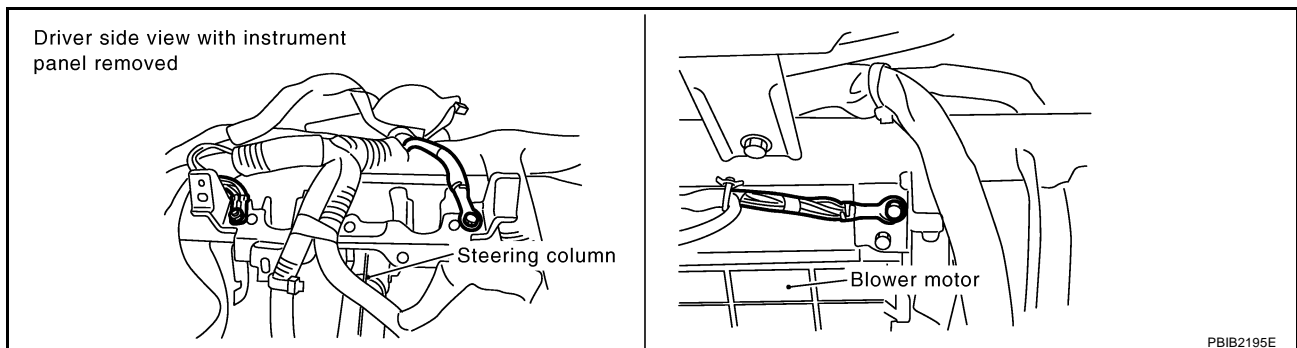

OK or NG

- OK >> GO TO 2.
NG >> Repair or replace ground connections.

2. CHECK THROTTLE CONTROL MOTOR OUTPUT SIGNAL CIRCUIT FOR OPEN OR SHORT

1. Disconnect electric throttle control actuator harness connector.
2. Disconnect ECM harness connector.
3. Check harness continuity between the following terminals. Refer to Wiring Diagram.

Electric throttle control actuator terminal	ECM terminal	Continuity
3	5	Should not exist
	4	Should exist
6	5	Should exist
	4	Should not exist

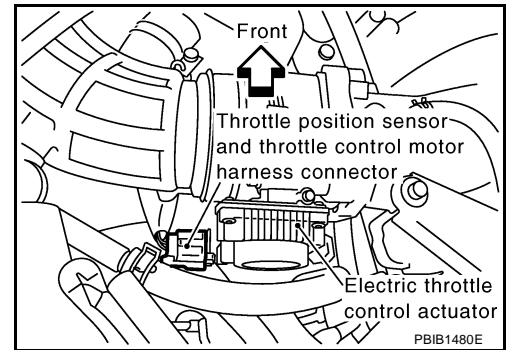

4. Also check harness for short to ground and short to power.

OK or NG

- OK >> GO TO 3.
- NG >> Repair or replace.

3. CHECK THROTTLE CONTROL MOTOR

Refer to [EC-1093, "Component Inspection"](#) .

OK or NG

- OK >> GO TO 4.
- NG >> GO TO 5.

4. CHECK INTERMITTENT INCIDENT

Refer to [EC-784, "TROUBLE DIAGNOSIS FOR INTERMITTENT INCIDENT"](#) .

OK or NG

- OK >> GO TO 5.
- NG >> Repair or replace harness or connectors.

5. REPLACE ELECTRIC THROTTLE CONTROL ACTUATOR

1. Replace the electric throttle control actuator.
2. Perform [EC-698, "Throttle Valve Closed Position Learning"](#) .
3. Perform [EC-698, "Idle Air Volume Learning"](#) .

>> **INSPECTION END**

Component Inspection THROTTLE CONTROL MOTOR

ABS00C96

1. Disconnect electric throttle control actuator harness connector.
2. Check resistance between terminals 3 and 6.

Resistance: Approximately 1 - 15 Ω [at 25 °C (77°F)]

3. If NG, replace electric throttle control actuator and go to next step.
4. Perform [EC-698, "Throttle Valve Closed Position Learning"](#) .
5. Perform [EC-698, "Idle Air Volume Learning"](#) .

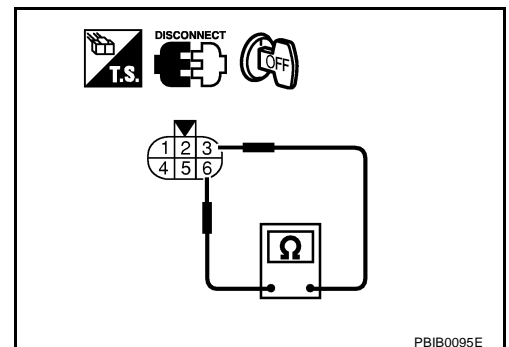

Removal and Installation
ELECTRIC THROTTLE CONTROL ACTUATOR

ABS00C97

Refer to [EM-174, "INTAKE MANIFOLD"](#) .

DTC P1140, P1145 IVT CONTROL POSITION SENSOR

PFP:23731

Component Description

ABS00C98

Intake valve timing control position sensors are located in the front of cylinder heads in both bank 1 and bank 2.

This sensor uses a Hall IC.

The cam position is determined by the intake primary cam sprocket concave (in four places). The ECM provides feedback to the intake valve timing control for appropriate target valve open-close timing according to drive conditions based on detected cam position.

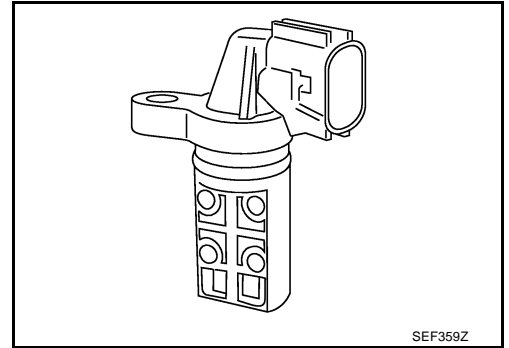

CONSULT-II Reference Value in Data Monitor Mode

ABS00C99

Specification data are reference values.

MONITOR ITEM	CONDITION		SPECIFICATION
INT/V TIM (B1) INT/V TIM (B2)	<ul style="list-style-type: none"> ● Engine: After warming up ● Air conditioner switch: OFF 	Idle	-5 - 5°C
	<ul style="list-style-type: none"> ● Shift lever: N ● No load 	2,000 rpm	Approx. 0 - 20°C

On Board Diagnosis Logic

ABS00C9A

DTC No.	Trouble diagnosis name	DTC detecting condition	Possible cause
P1140 1140 (bank 1)	Intake valve timing control position sensor circuit	An excessively high or low voltage from the sensor is sent to ECM.	<ul style="list-style-type: none"> ● Harness or connectors (Intake valve timing control position sensor circuit is open or shorted) ● Intake valve timing control position sensor ● Crankshaft position sensor (POS) ● Camshaft position sensor (PHASE) ● Accumulation of debris to the signal pick-up portion of the camshaft
P1145 1145 (bank 2)			

DTC Confirmation Procedure

ABS00C9B

NOTE:

If DTC Confirmation Procedure has been previously conducted, always turn ignition switch OFF and wait at least 10 seconds before conducting the next test.

WITH CONSULT-II

1. Turn ignition switch ON.
2. Select "DATA MONITOR" mode with CONSULT-II.
3. Maintain the following conditions for at least 10 seconds.

ENG SPEED	More than idle speed
Selector lever	P or N position

4. If 1st trip DTC is detected, go to [EC-1099, "Diagnostic Procedure"](#).

WITH GST

Follow the procedure "WITH CONSULT-II" above.

DTC P1140, P1145 IVT CONTROL POSITION SENSOR

[VK45DE]

ABS00C9C

Wiring Diagram BANK 1

EC-IVCSB1-01

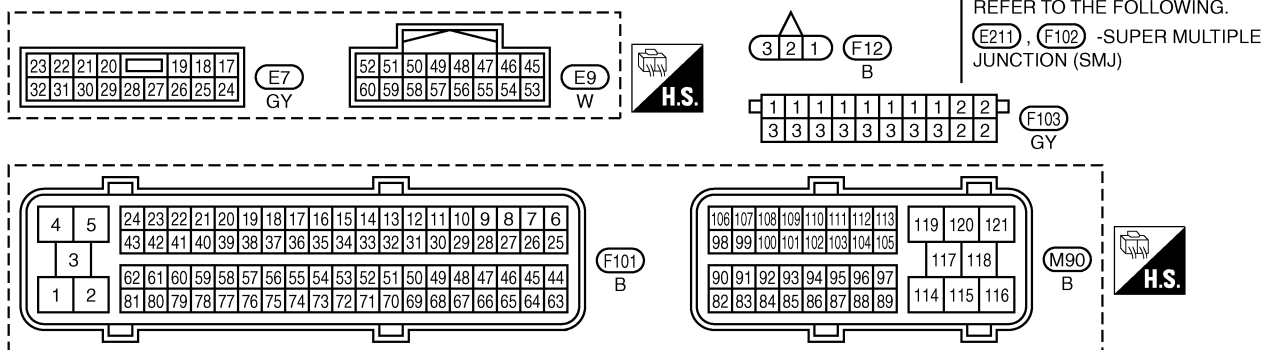
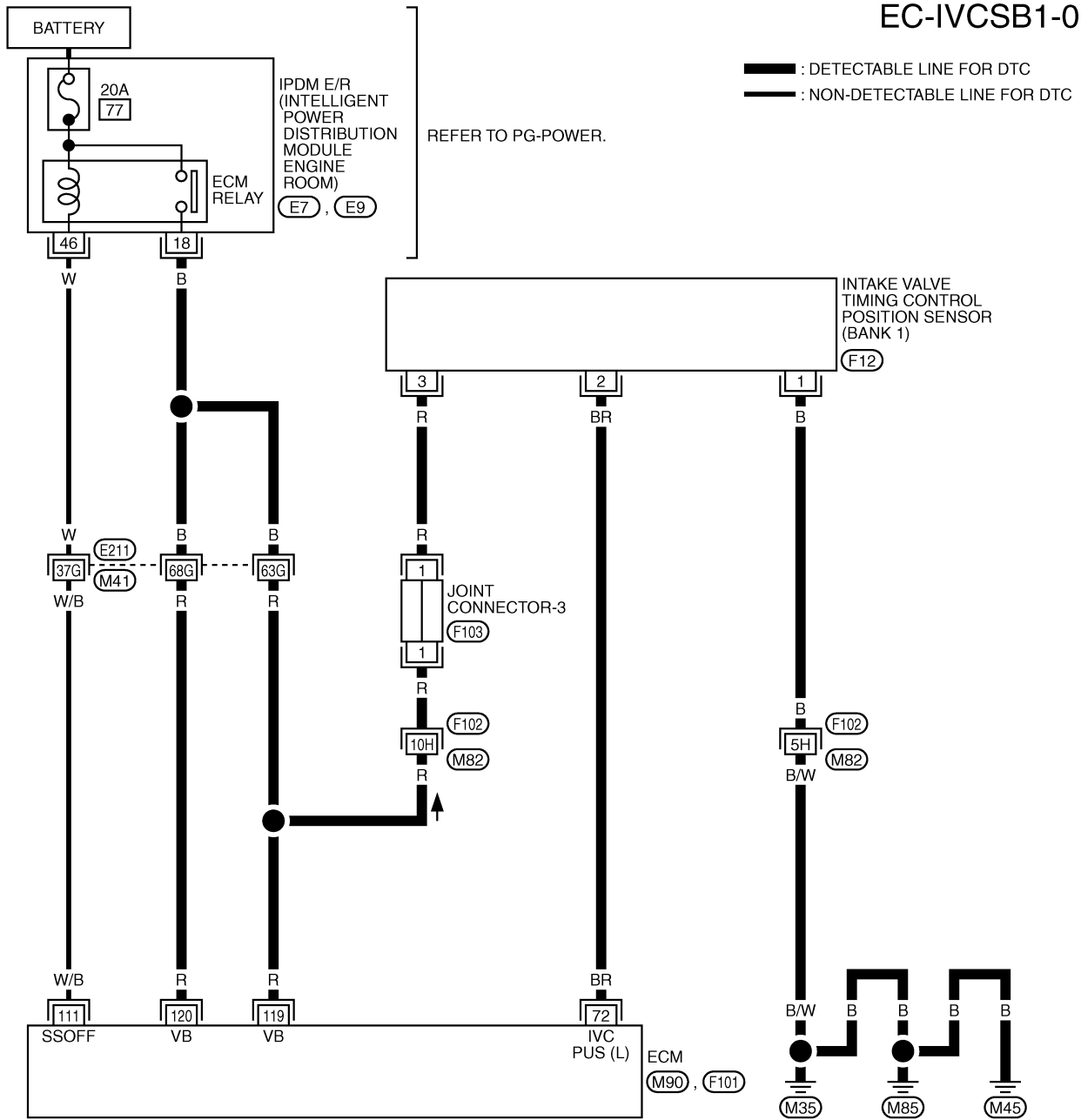

TBWM0244E

DTC P1140, P1145 IVT CONTROL POSITION SENSOR

[VK45DE]

Specification data are reference values and are measured between each terminal and ground.
Pulse signal is measured by CONSULT-II.

CAUTION:

Do not use ECM ground terminals when measuring input/output voltage. Doing so may result in damage to the ECM's transistor. Use a ground other than ECM terminals, such as the ground.

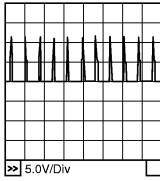
TER-MINAL NO.	WIRE COLOR	ITEM	CONDITION	DATA (DC Voltage)
72	BR	Intake valve timing control position sensor (bank 1)	[Engine is running] <ul style="list-style-type: none"> ● Warm-up condition ● Idle speed 	0 - 1.0V
			[Engine is running] <ul style="list-style-type: none"> ● Engine speed is 2,000 rpm 	0 - 1.0V★ 

★: Average voltage for pulse signal (Actual pulse signal can be confirmed by oscilloscope.)

A
EC
C
D
E
F
G
H
I
J
K
L
M

DTC P1140, P1145 IVT CONTROL POSITION SENSOR

[VK45DE]

BANK 2

EC-IVCSB2-01

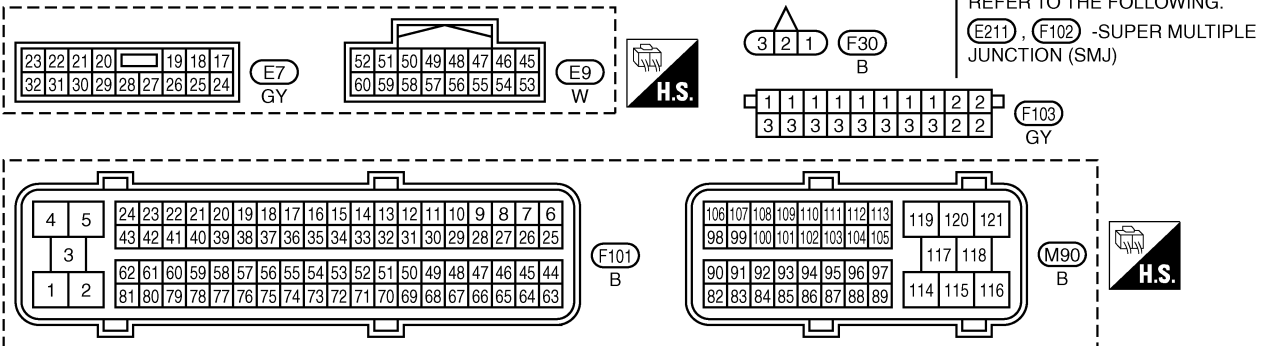
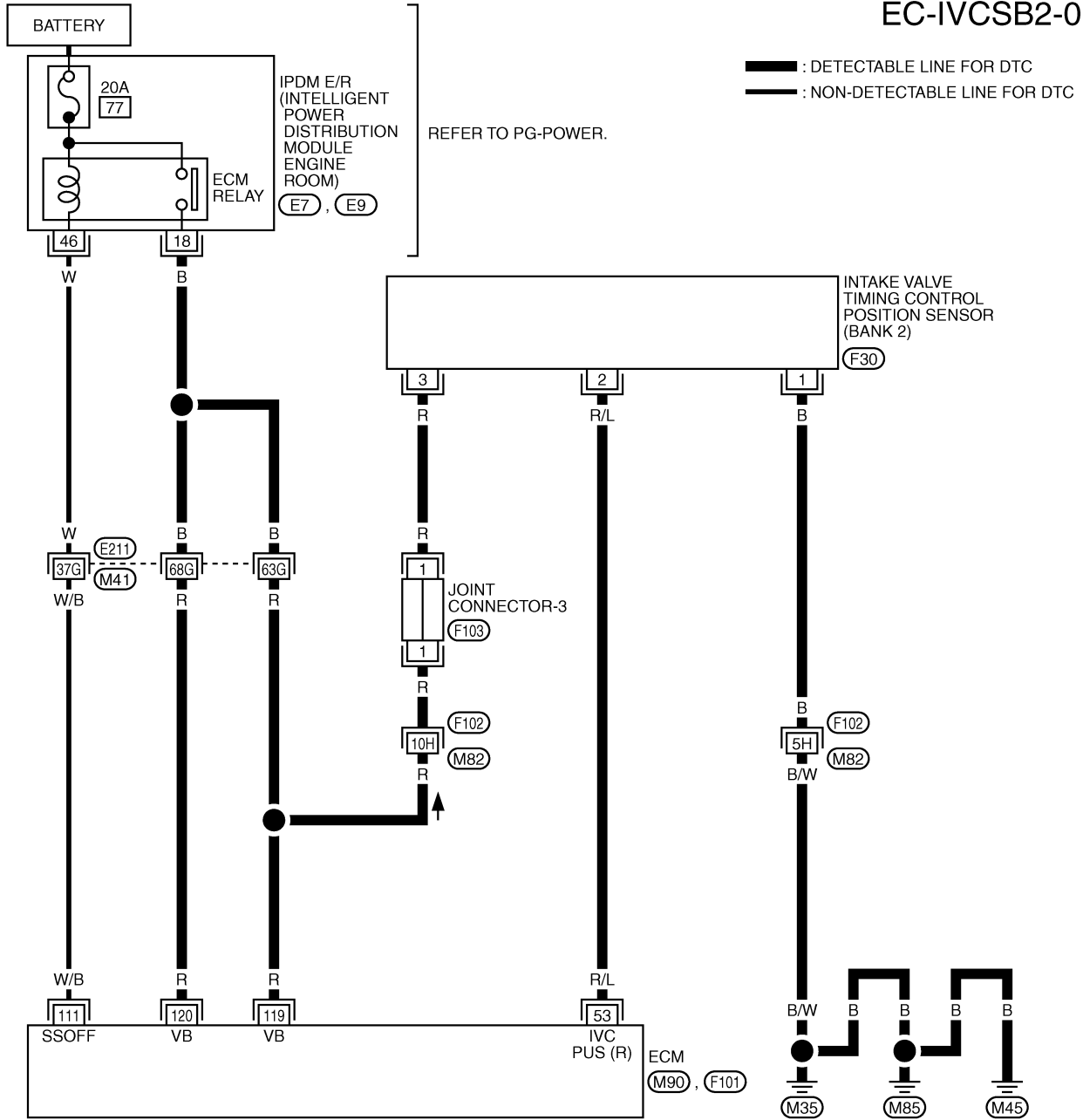

TBWM0245E

DTC P1140, P1145 IVT CONTROL POSITION SENSOR

[VK45DE]

Specification data are reference values and are measured between each terminal and ground.
Pulse signal is measured by CONSULT-II.

CAUTION:

Do not use ECM ground terminals when measuring input/output voltage. Doing so may result in damage to the ECM's transistor. Use a ground other than ECM terminals, such as the ground.

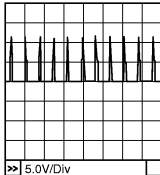
TER-MINAL NO.	WIRE COLOR	ITEM	CONDITION	DATA (DC Voltage)
53	R/L	Intake valve timing control position sensor (bank 2)	[Engine is running] ● Warm-up condition ● Idle speed	0 - 1.0V
			[Engine is running] ● Engine speed is 2,000 rpm	0 - 1.0V★  PBIB2046E

★: Average voltage for pulse signal (Actual pulse signal can be confirmed by oscilloscope.)

Diagnostic Procedure

ABS00C9D

1. CHECK GROUND CONNECTIONS

1. Turn ignition switch OFF.
2. Loosen and retighten three ground screws on the body.
Refer to [EC-791, "Ground Inspection"](#).

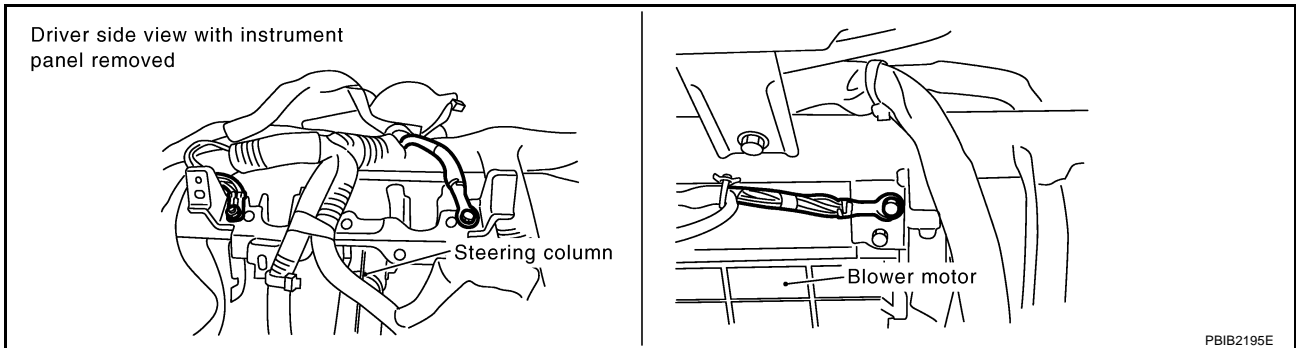

OK or NG

- OK >> GO TO 2.
- NG >> Repair or replace ground connections.

2. CHECK INTAKE VALVE TIMING CONTROL POSITION SENSOR POWER SUPPLY CIRCUIT

1. Disconnect intake valve timing control position sensor harness connector.

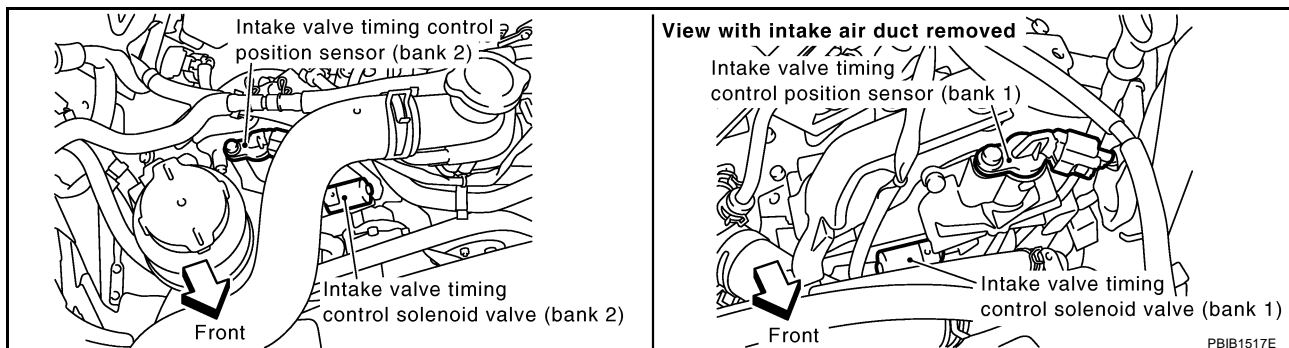

2. Turn ignition switch ON.
3. Check voltage between intake valve timing control position sensor terminal 3 and ground with CONSULT-II or tester.

Voltage: Battery voltage

OK or NG

- OK >> GO TO 4.
- NG >> GO TO 3.

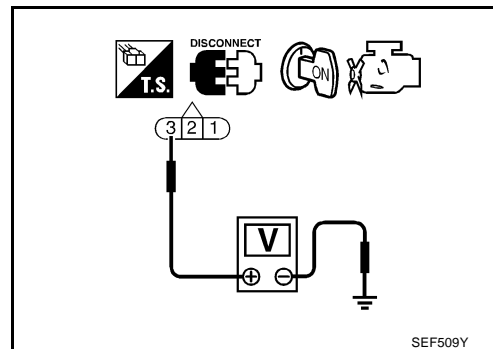

3. DETECT MALFUNCTIONING PART

Check the following.

- Harness connectors E211, M41
- Harness connectors F102, M82
- Joint connector-3
- Harness for open or short between intake valve timing control position sensor and IPDM E/R
- Harness for open or short between intake valve timing control position sensor and ECM

>> Repair open circuit or short to ground or short to power in harness or connectors.

4. CHECK INTAKE VALVE TIMING CONTROL POSITION SENSOR GROUND CIRCUIT FOR OPEN AND SHORT

1. Turn ignition switch OFF.
2. Check harness continuity between intake valve timing control position sensor terminal 1 and ground. Refer to Wiring Diagram.

Continuity should exist.

3. Also check harness for short to power.

OK or NG

- OK >> GO TO 6.
- NG >> GO TO 5.

5. DETECT MALFUNCTIONING PART

Check the following.

- Harness connectors F102, M82
- Harness for open or short between intake valve timing control position sensor and ground

>> Repair open circuit or short to power in harness or connectors.

6. CHECK INTAKE VALVE TIMING CONTROL POSITION SENSOR INPUT SIGNAL CIRCUIT FOR OPEN AND SHORT

1. Disconnect ECM harness connector.
2. Check harness continuity between ECM terminal 72 and intake valve timing control position sensor (bank 1) terminal 2 or ECM terminal 53 and intake valve timing control position sensor (bank 2) terminal 2. Refer to Wiring Diagram.

Continuity should exist.

3. Also check harness for short to ground and short to power.

OK or NG

OK >> GO TO 7.

NG >> Repair open circuit or short to ground or short to power in harness or connectors.

7. CHECK INTAKE VALVE TIMING CONTROL POSITION SENSOR

Refer to [EC-1102, "Component Inspection"](#) .

OK or NG

OK >> GO TO 8.

NG >> Replace intake valve timing control position sensor.

8. CHECK CRANKSHAFT POSITION SENSOR (POS)

Refer to [EC-964, "Component Inspection"](#) .

OK or NG

OK >> GO TO 9.

NG >> Replace crankshaft position sensor (POS).

9. CHECK CAMSHAFT POSITION SENSOR (PHASE)

Refer to [EC-970, "Component Inspection"](#) .

OK or NG

OK >> GO TO 10.

NG >> Replace camshaft position sensor (PHASE).

10. CHECK CAMSHAFT

Check accumulation of debris to the signal pick-up portion of the camshaft. Refer to [EM-196, "TIMING CHAIN"](#) .

OK or NG

OK >> GO TO 11.

NG >> Remove debris and clean the signal pick-up cutout of camshaft.

11. CHECK INTERMITTENT INCIDENT

Refer to [EC-784, "TROUBLE DIAGNOSIS FOR INTERMITTENT INCIDENT"](#) .

>> INSPECTION END

Component Inspection

INTAKE VALVE TIMING CONTROL POSITION SENSOR

ABS00C9E

1. Disconnect intake valve timing control position sensor harness connector.
2. Loosen the fixing bolt of the sensor.
3. Remove the sensor.
4. Visually check the sensor for chipping.

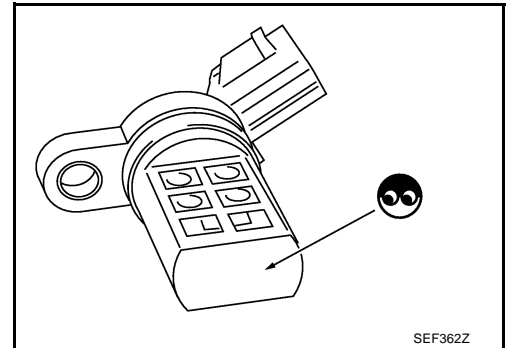

5. Check resistance as shown below.

Terminal No. (Polarity)	Resistance Ω [at 25°C (77°F)]
3 (+) - 1 (-)	Except 0 or ∞
2 (+) - 1 (-)	
3 (+) - 2 (-)	

6. If NG, replace intake valve timing control position sensor.

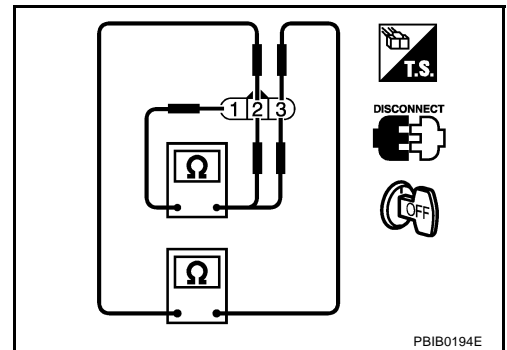

Removal and Installation

INTAKE VALVE TIMING CONTROL POSITION SENSOR

ABS00C9F

Refer to [EM-196, "TIMING CHAIN"](#) .

DTC P1143, P1163 HO2S1

PFP:22690

Component Description

ABS00C9G

The heated oxygen sensor 1 is placed into the exhaust manifold. It detects the amount of oxygen in the exhaust gas compared to the outside air. The heated oxygen sensor 1 has a closed-end tube made of ceramic zirconia. The zirconia generates voltage from approximately 1V in richer conditions to 0V in leaner conditions. The heated oxygen sensor 1 signal is sent to the ECM. The ECM adjusts the injection pulse duration to achieve the ideal air-fuel ratio. The ideal air-fuel ratio occurs near the radical change from 1 to 0V.

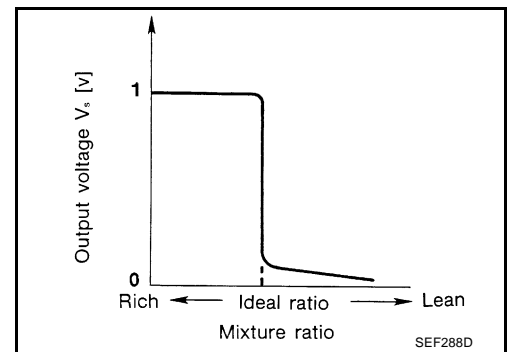
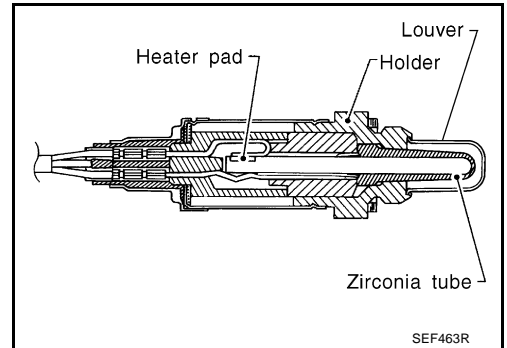

CONSULT-II Reference Value in Data Monitor Mode

ABS00C9H

Specification data are reference values.

MONITOR ITEM	CONDITION		SPECIFICATION
HO2S1 (B1) HO2S1 (B2)	● Engine: After warming up	Maintaining engine speed at 2,000 rpm	0 - 0.3V ←→ Approx. 0.6 - 1.0V
HO2S1 MNTR (B1) HO2S1 MNTR (B2)			LEAN ←→ RICH Changes more than 5 times during 10 seconds.

On Board Diagnosis Logic

ABS00C9I

To judge the malfunction, the output from the heated oxygen sensor 1 is monitored to determine whether the rich output is sufficiently high and whether the lean output is sufficiently low. When both the outputs are shifting to the lean side, the malfunction will be detected.

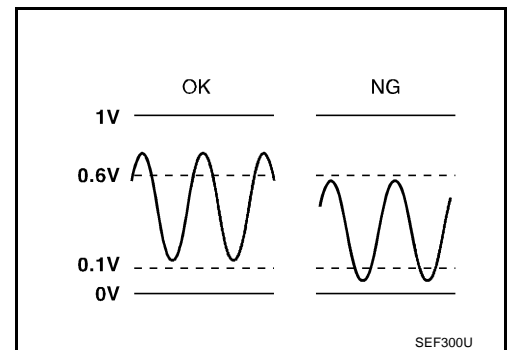

DTC No.	Trouble diagnosis name	DTC detecting condition	Possible cause
P1143 1143 (Bank 1)	Heated oxygen sensor 1 lean shift monitoring	The maximum and minimum voltage from the sensor are not reached to the specified voltages.	<ul style="list-style-type: none"> ● Heated oxygen sensor 1 ● Heated oxygen sensor 1 heater ● Fuel pressure ● Fuel injector ● Intake air leaks
P1163 1163 (Bank 2)			

DTC Confirmation Procedure

CAUTION:

Always drive vehicle at a safe speed.

NOTE:

If DTC Confirmation Procedure has been previously conducted, always turn ignition switch OFF and wait at least 10 seconds before conducting the next test.

TESTING CONDITION:

- Always perform at a temperature above -10°C (14°F).
- Before performing following procedure, confirm that battery voltage is more than 11V at idle.

WITH CONSULT-II

1. Start engine and warm it up to normal operating temperature.
2. Stop engine and wait at least 10 seconds.
3. Turn ignition switch ON and select "HO2S1 (B1) P1143" of "HO2S1" or "HO2S1 (B2) P1163" of "HO2S1" in "DTC WORK SUPPORT" mode with CONSULT-II.
4. Touch "START".
5. Start engine and let it idle for at least 3 minutes.

NOTE:

Do not raise engine speed above 3,000 rpm after this step. If the engine speed limit is exceeded, return to step 5.

HO2S1 (B1) P1143	
OUT OF CONDITION	
MONITOR	
ENG SPEED	XXX rpm
B/FUEL SCHDL	XXX msec
COOLAN TEMP/S	XXX °C
VHCL SPEED SEN	XXX km/h

PBIB0546E

6. When the following conditions are met, "TESTING" will be displayed on the CONSULT-II screen. Maintain the conditions continuously until "TESTING" changes to "COMPLETED". (It will take approximately 40 seconds or more.)

ENG SPEED	1,200 - 2,500 rpm
VHCL SPEED SE	Less than 100 km/h (62 MPH)
B/FUEL SCHDL	1.6 - 12.0 msec
Selector lever	Suitable position

If "TESTING" is not displayed after 5 minutes, retry from step 2.

7. Make sure that "OK" is displayed after touching "SELF-DIAG RESULTS". If "NG" is displayed, refer to [EC-1105, "Diagnostic Procedure"](#).

HO2S1 (B1) P1143	
TESTING	
MONITOR	
ENG SPEED	XXX rpm
B/FUEL SCHDL	XXX msec
COOLAN TEMP/S	XXX °C
VHCL SPEED SEN	XXX km/h

PBIB0547E

HO2S1 (B1) P1143	
COMPLETED	

SEC769C

Overall Function Check

Use this procedure to check the overall function of the heated oxygen sensor 1 circuit. During this check, a 1st trip DTC might not be confirmed.

WITH GST

1. Start engine and warm it up to normal operating temperature.
2. Set voltmeter probes between ECM terminal 16 [HO2S1(B1) signal] or 35 [HO2S1(B2) signal] and ground.
3. Check one of the following with engine speed held at 2,000 rpm constant under no load.
 - The maximum voltage is over 0.6V at least 1 time.
 - The minimum voltage is over 0.1V at least 1 time.
4. If NG, go to [EC-1105, "Diagnostic Procedure"](#).

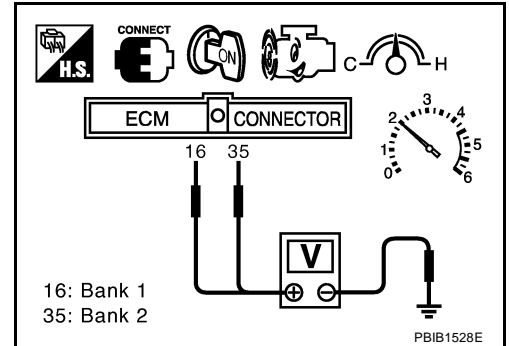

Diagnostic Procedure

1. CHECK GROUND CONNECTIONS

1. Turn ignition switch OFF.
2. Loosen and retighten three ground screws on the body.
Refer to [EC-791, "Ground Inspection"](#).

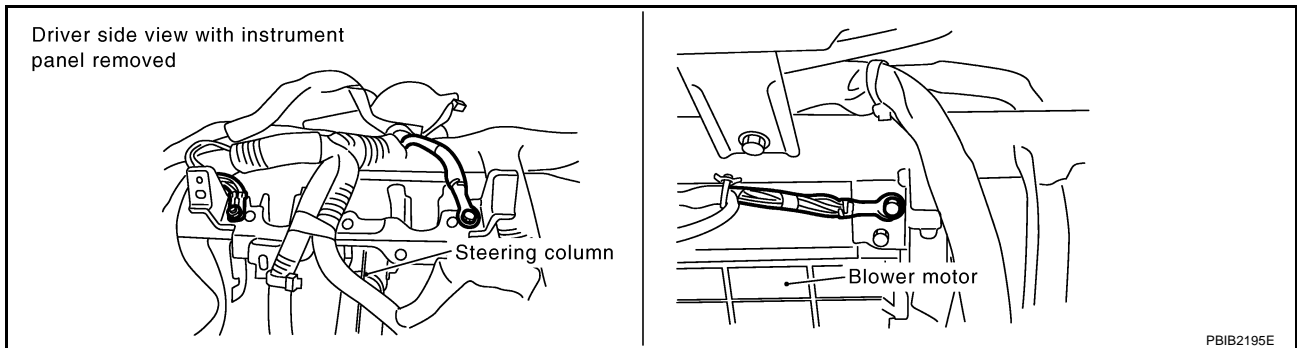

OK or NG

- OK >> GO TO 2.
- NG >> Repair or replace ground connections.

2. RETIGHTEN HEATED OXYGEN SENSOR 1

Loosen and retighten corresponding heated oxygen sensor 1.

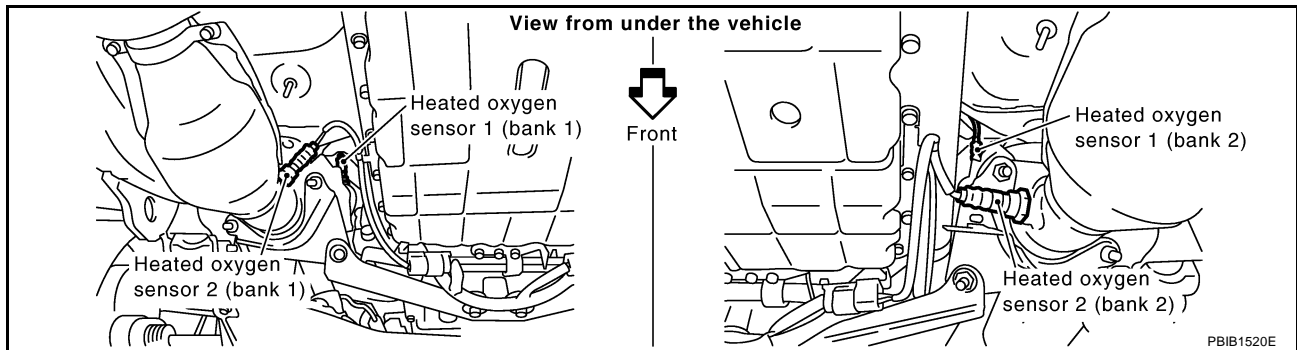

Tightening torque: 50 N·m (5.1 kg·m, 37 ft·lb)

>> GO TO 3.

3. CLEAR THE SELF-LEARNING DATA

With CONSULT-II

1. Start engine and warm it up to normal operating temperature.
2. Select "SELF-LEARNING CONT" in "WORK SUPPORT" mode with CONSULT-II.
3. Clear the self-learning control coefficient by touching "CLEAR".
4. Run engine for at least 10 minutes at idle speed.
**Is the 1st trip DTC P0171 or P0174 detected?
Is it difficult to start engine?**

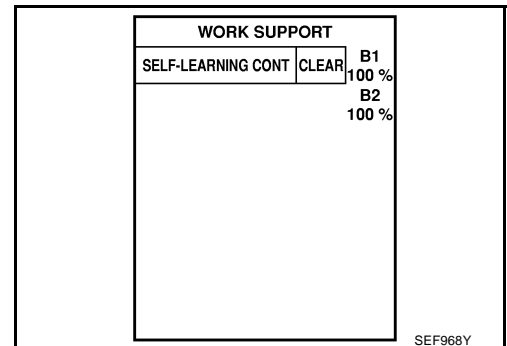

With GST

1. Start engine and warm it up to normal operating temperature.
2. Turn ignition switch OFF.
3. Disconnect mass air flow sensor harness connector, and restart and run engine for at least 5 seconds at idle speed.
4. Stop engine and reconnect mass air flow sensor harness connector.
5. Make sure DTC P0102 is displayed.
6. Erase the DTC memory. Refer to [EC-715. "HOW TO ERASE EMISSION-RELATED DIAGNOSTIC INFORMATION"](#).
7. Make sure DTC P0000 is displayed.
8. Run engine for at least 10 minutes at idle speed.
**Is the 1st trip DTC P0171 or P0174 detected?
Is it difficult to start engine?**

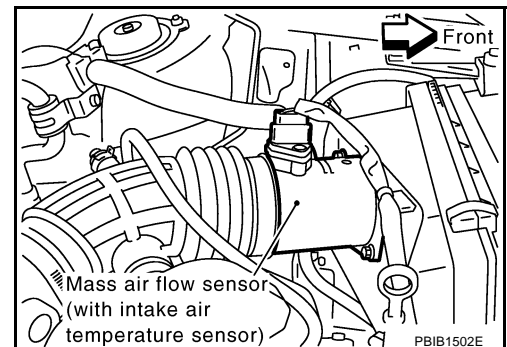

Yes or No

- Yes >> Perform trouble diagnosis for DTC P0171, P0174. Refer to [EC-914](#).
- No >> GO TO 4.

4. CHECK HEATED OXYGEN SENSOR 1 HEATER

Refer to [EC-813, "Component Inspection"](#) .

OK or NG

- OK >> GO TO 5.
- NG >> Replace malfunctioning heated oxygen sensor 1.

5. CHECK HEATED OXYGEN SENSOR 1

Refer to [EC-1107, "Component Inspection"](#) .

OK or NG

- OK >> GO TO 6.
- NG >> Replace malfunctioning heated oxygen sensor 1.

6. CHECK INTERMITTENT INCIDENT

Refer to [EC-784, "TROUBLE DIAGNOSIS FOR INTERMITTENT INCIDENT"](#) .
 For circuit, refer to [EC-865, "Wiring Diagram"](#) .

>> INSPECTION END

Component Inspection HEATED OXYGEN SENSOR 1

ABS00C9M

Ⓟ With CONSULT-II

1. Start engine and warm it up to normal operating temperature.
2. Select "MANU TRIG" and adjust "TRIGGER POINT" to 100% in "DATA MONITOR" mode with CONSULT-II.
3. Select "HO2S1 (B1)/(B2)" and "HO2S1 MNTR (B1)/(B2)".
4. Hold engine speed at 2,000 rpm under no load during the following steps.
5. Touch "RECORD" on CONSULT-II screen.

DATA MONITOR	
MONITOR	NO DTC
ENG SPEED	XXX rpm
MAS A/F SE-B1	XXX V
COOLAN TEMP/S	XXX °C
HO2S1 (B1)	XXX V
HO2S1 MNTR (B1)	LEAN

SEF646Y

6. Check the following.
 - "HO2S1 MNTR (B1)/(B2)" in "DATA MONITOR" mode changes from "RICH" to "LEAN" to "RICH" more than 5 times in 10 seconds.
5 times (cycles) are counted as shown at right.
 - "HO2S1 (B1)/(B2)" voltage goes above 0.6V at least once.
 - "HO2S1 (B1)/(B2)" voltage goes below 0.3V at least once.
 - "HO2S1 (B1)/(B2)" voltage never exceeds 1.0V.

Bank 1	cycle	1	2	3	4	5	
	HO2S1 MNTR (B1)	R-L-R-L-R-L-R-L-R-L-R					
Bank 2	cycle	1	2	3	4	5	
	HO2S1 MNTR (B2)	R-L-R-L-R-L-R-L-R-L-R					
R means HO2S1 MNTR (B1)/(B2) indicates RICH							
L means HO2S1 MNTR (B1)/(B2) indicates LEAN							

SEF647Y

DTC P1144, P1164 HO2S1

PFP:22690

Component Description

ABS00C90

The heated oxygen sensor 1 is placed into the exhaust manifold. It detects the amount of oxygen in the exhaust gas compared to the outside air. The heated oxygen sensor 1 has a closed-end tube made of ceramic zirconia. The zirconia generates voltage from approximately 1V in richer conditions to 0V in leaner conditions. The heated oxygen sensor 1 signal is sent to the ECM. The ECM adjusts the injection pulse duration to achieve the ideal air-fuel ratio. The ideal air-fuel ratio occurs near the radical change from 1 to 0V.

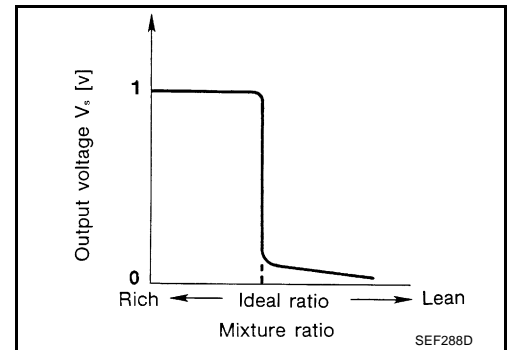
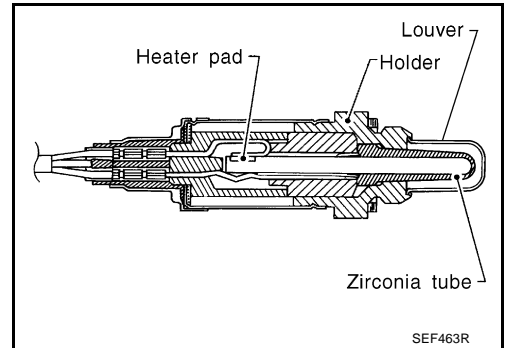

CONSULT-II Reference Value in Data Monitor Mode

ABS00C9P

Specification data are reference values.

MONITOR ITEM	CONDITION		SPECIFICATION
HO2S1 (B1) HO2S1 (B2)	● Engine: After warming up	Maintaining engine speed at 2,000 rpm	0 - 0.3V ←→ Approx. 0.6 - 1.0V
HO2S1 MNTR (B1) HO2S1 MNTR (B2)			LEAN ←→ RICH Changes more than 5 times during 10 seconds.

On Board Diagnosis Logic

ABS00C9Q

To judge the malfunction, the output from the heated oxygen sensor 1 is monitored to determine whether the rich output is sufficiently high and lean output is sufficiently low. When both the outputs are shifting to the rich side, the malfunction will be detected.

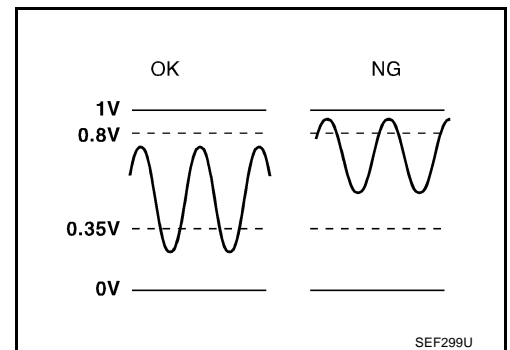

DTC No.	Trouble diagnosis name	DTC detecting condition	Possible cause
P1144 1144 (Bank 1)	Heated oxygen sensor 1 rich shift monitoring	The maximum and minimum voltages from the sensor are beyond the specified voltages.	<ul style="list-style-type: none"> ● Heated oxygen sensor 1 ● Heated oxygen sensor 1 heater ● Fuel pressure ● Fuel injector
P1164 1164 (Bank 2)			

DTC Confirmation Procedure

CAUTION:

Always drive vehicle at a safe speed.

NOTE:

If DTC Confirmation Procedure has been previously conducted, always turn ignition switch OFF and wait at least 10 seconds before conducting the next test.

TESTING CONDITION:

- Always perform at a temperature above -10°C (14°F).
- Before performing the following procedure, confirm that battery voltage is more than 11V at idle.

WITH CONSULT-II

1. Start engine and warm it up to normal operating temperature.
2. Stop engine and wait at least 5 seconds.
3. Turn ignition switch ON and select "HO2S1 (B1) P1144" or "HO2S1 (B2) P1164" of "HO2S1" in "DTC WORK SUPPORT" mode with CONSULT-II.
4. Touch "START".
5. Start engine and let it idle for at least 3 minutes.

NOTE:

Do not raise engine speed above 3,000 rpm after this step. If the engine speed limit is exceeded, return to step 5.

HO2S1 (B1) P1144	
OUT OF CONDITION	
MONITOR	
ENG SPEED	XXX rpm
B/FUEL SCHDL	XXX msec
COOLAN TEMP/S	XXX °C
VHCL SPEED SEN	XXX km/h

PBIB0548E

6. When the following conditions are met, "TESTING" will be displayed on the CONSULT-II screen. Maintain the conditions continuously until "TESTING" changes to "COMPLETED". (It will take approximately 40 seconds or more.)

ENG SPEED	1,200 - 2,500 rpm
VHCL SPEED SE	Less than 100 km/h (62 MPH)
B/FUEL SCHDL	1.6 - 12.0 msec
Selector lever	Suitable position

HO2S1 (B1) P1144	
TESTING	
MONITOR	
ENG SPEED	XXX rpm
B/FUEL SCHDL	XXX msec
COOLAN TEMP/S	XXX °C
VHCL SPEED SEN	XXX km/h

PBIB0549E

If "TESTING" is not displayed after 5 minutes, retry from step 2.

7. Make sure that "OK" is displayed after touching "SELF-DIAG RESULTS". If "NG" is displayed, refer to [EC-1111, "Diagnostic Procedure"](#).

HO2S1 (B1) P1144	
COMPLETED	

SEC772C

Overall Function Check

Use this procedure to check the overall function of the heated oxygen sensor 1 circuit. During this check, a 1st trip DTC might not be confirmed.

WITH GST

1. Start engine and warm it up to normal operating temperature.
2. Set voltmeter probes between ECM terminal 16 [HO2S1(B1) signal] 35 [HO2S1(B2) signal] and ground.
3. Check one of the following with engine speed held at 2,000 rpm constant under no load.
 - The maximum voltage is below 0.8V at least 1 time.
 - The minimum voltage is below 0.35V at least 1 time.
4. If NG, go to [EC-1111, "Diagnostic Procedure"](#) .

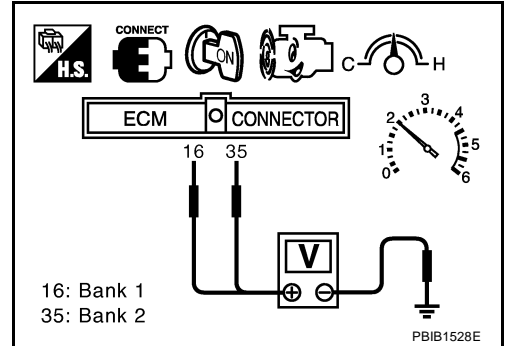

Diagnostic Procedure

1. CHECK GROUND CONNECTIONS

1. Turn ignition switch OFF.
2. Loosen and retighten three ground screws on the body.
Refer to [EC-791, "Ground Inspection"](#) .

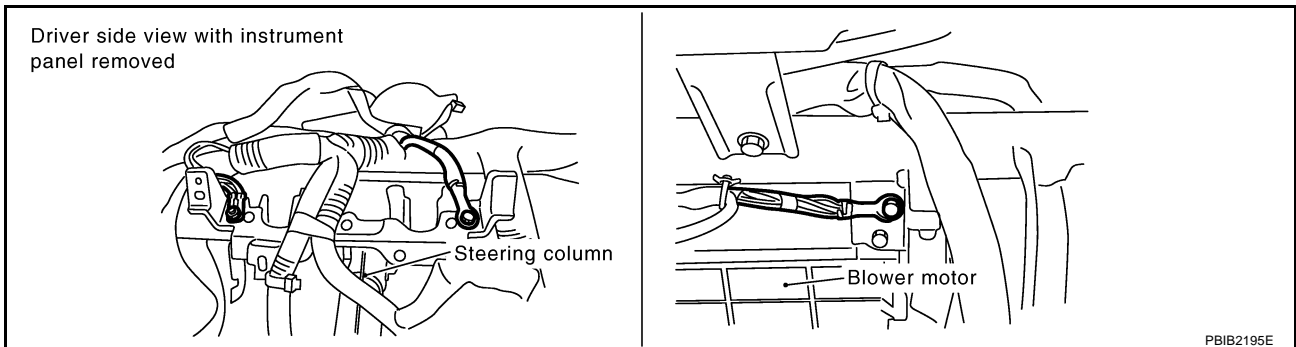

OK or NG

- OK >> GO TO 2.
- NG >> Repair or replace ground connections.

2. RETIGHTEN HEATED OXYGEN SENSOR 1

Loosen and retighten heated oxygen sensor 1.

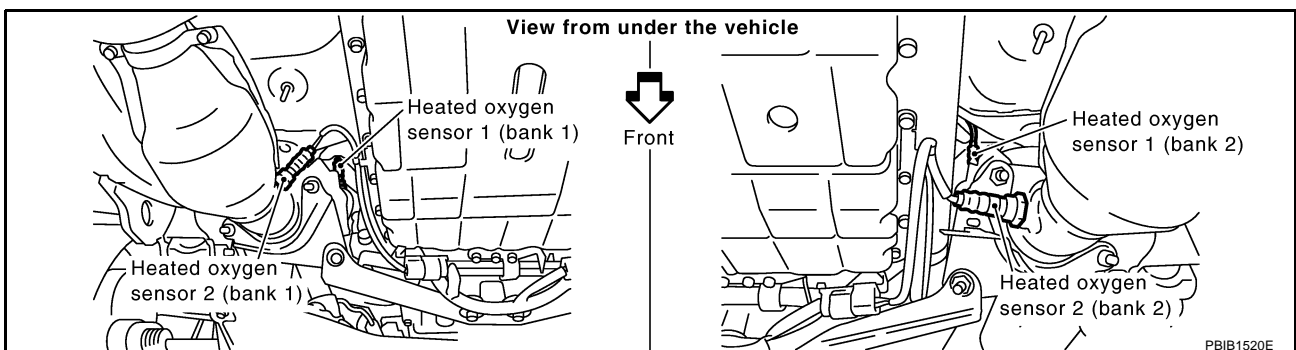

Tightening torque: 50 N-m (5.1 kg-m, 37 ft-lb)

>> GO TO 3.

3. CLEAR THE SELF-LEARNING DATA

With CONSULT-II

1. Start engine and warm it up to normal operating temperature.
2. Select "SELF-LEARNING CONT" in "WORK SUPPORT" mode with CONSULT-II.
3. Clear the self-learning control coefficient by touching "CLEAR".
4. Run engine for at least 10 minutes at idle speed.
Is the 1st trip DTC P0172 or P0175 detected?
Is it difficult to start engine?

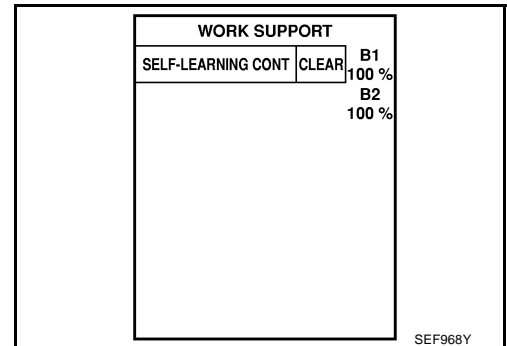

With GST

1. Start engine and warm it up to normal operating temperature.
2. Turn ignition switch OFF.
3. Disconnect mass air flow sensor harness connector, and restart and run engine for at least 5 seconds at idle speed.
4. Stop engine and reconnect mass air flow sensor harness connector.
5. Make sure DTC P0102 is displayed.
6. Erase the DTC memory. Refer to [EC-715, "HOW TO ERASE EMISSION-RELATED DIAGNOSTIC INFORMATION"](#).
7. Make sure DTC P0000 is displayed.
8. Run engine for at least 10 minutes at idle speed.
Is the 1st trip DTC P0172 or P0175 detected?
Is it difficult to start engine?

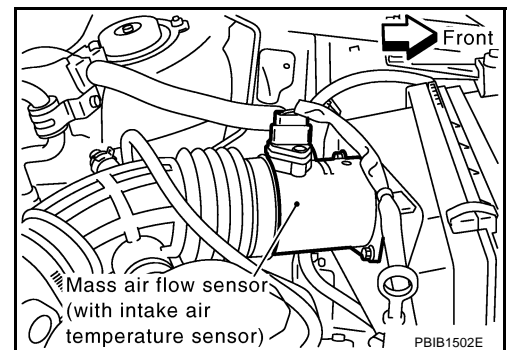

Yes or No

- Yes >> Perform trouble diagnosis for DTC P0172, P0175. Refer to [EC-923](#).
- No >> GO TO 4.

4. CHECK HO2S1 CONNECTOR FOR WATER

1. Turn ignition switch OFF.
2. Disconnect heated oxygen sensor 1 harness connector.

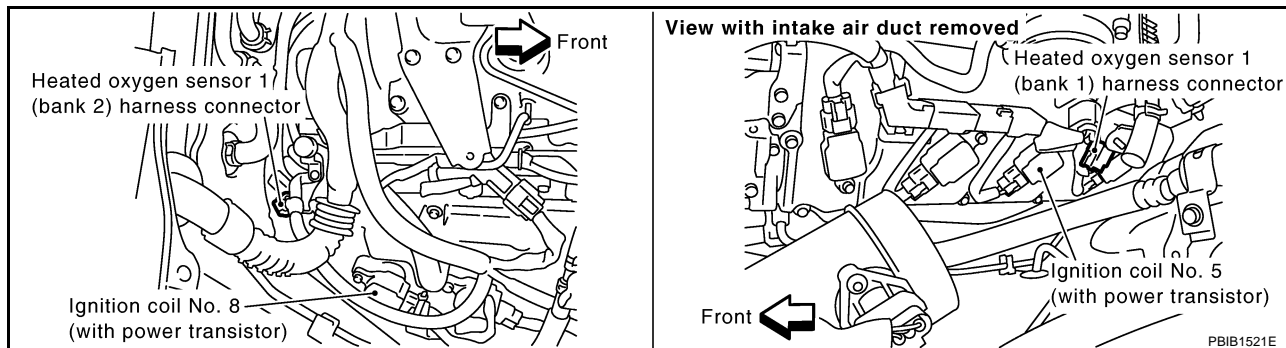

3. Check connectors for water.

Water should not exist.

OK or NG

- OK >> GO TO 5.
 NG >> Repair or replace harness or connectors.

5. CHECK HEATED OXYGEN SENSOR 1 HEATER

Refer to [EC-813, "Component Inspection"](#) .

OK or NG

- OK >> GO TO 6.
 NG >> Replace malfunctioning heated oxygen sensor 1.

6. CHECK HEATED OXYGEN SENSOR 1

Refer to [EC-1113, "Component Inspection"](#) .

OK or NG

- OK >> GO TO 7.
 NG >> Replace malfunctioning heated oxygen sensor 1.

7. CHECK INTERMITTENT INCIDENT

Refer to [EC-784, "TROUBLE DIAGNOSIS FOR INTERMITTENT INCIDENT"](#) .
 For circuit, refer to [EC-865, "Wiring Diagram"](#) .

>> INSPECTION END

Component Inspection HEATED OXYGEN SENSOR 1

ABS00C9U

Ⓟ With CONSULT-II

1. Start engine and warm it up to normal operating temperature.
2. Select "MANU TRIG" and adjust "TRIGGER POINT" to 100% in "DATA MONITOR" mode with CONSULT-II.
3. Select "HO2S1 (B1)" and "HO2S1 MNTR (B1)".
4. Hold engine speed at 2,000 rpm under no load during the following steps.

5. Touch "RECORD" on CONSULT-II screen.

DATA MONITOR	
MONITOR	NO DTC
ENG SPEED	XXX rpm
MAS A/F SE-B1	XXX V
COOLANT TEMP/S	XXX °C
HO2S1 (B1)	XXX V
HO2S1 MNTR (B1)	LEAN

SEF646Y

6. Check the following.

- "HO2S1 MNTR (B1)/(B2)" in "DATA MONITOR" mode changes from "RICH" to "LEAN" to "RICH" more than 5 times in 10 seconds.
5 times (cycles) are counted as shown at right.
- "HO2S1 (B1)/(B2)" voltage goes above 0.6V at least once.
- "HO2S1 (B1)/(B2)" voltage goes below 0.3V at least once.
- "HO2S1 (B1)/(B2)" voltage never exceeds 1.0V.

Bank 1	cycle	1	2	3	4	5	
	HO2S1 MNTR (B1)	R	-	L	-	R	-
Bank 2	cycle	1	2	3	4	5	
	HO2S1 MNTR (B2)	R	-	L	-	R	-

R means HO2S1
MNTR (B1)/(B2) indicates RICH
L means HO2S1
MNTR (B1)/(B2) indicates LEAN

SEF647Y

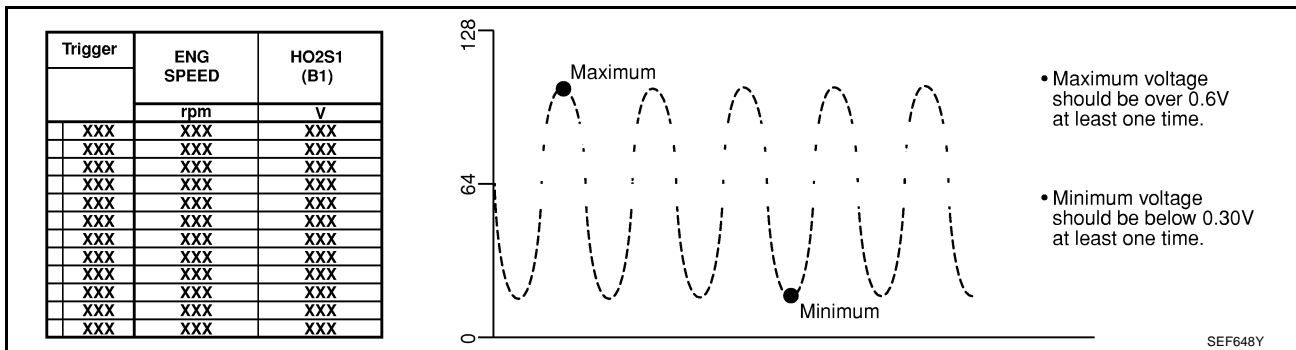

CAUTION:

- Discard any heated oxygen sensor which has been dropped from a height of more than 0.5 m (19.7 in) onto a hard surface such as a concrete floor; use a new one.
- Before installing new oxygen sensor, clean exhaust system threads using Oxygen Sensor Thread Cleaner tool J-43897-18 or J-43897-12 and approved anti-seize lubricant.

Without CONSULT-II

1. Start engine and warm it up to normal operating temperature.
2. Set voltmeter probes between ECM terminal 16 [HO2S1 (B1) signal] or 35 [HO2S1 (B2) signal] and ground.
3. Check the following with engine speed held at 2,000 rpm constant under no load.
 - The voltage fluctuates between 0 to 0.3V and 0.6 to 1.0V more than 5 times within 10 seconds.
 - The maximum voltage is over 0.6V at least 1 time.
 - The minimum voltage is below 0.3V at least 1 time.
 - The voltage never exceeds 1.0V.

1 time: 0 - 0.3V → 0.6 - 1.0V → 0 - 0.3V
 2 times: 0 - 0.3V → 0.6 - 1.0V → 0 - 0.3V → 0.6 - 1.0V → 0 - 0.3V

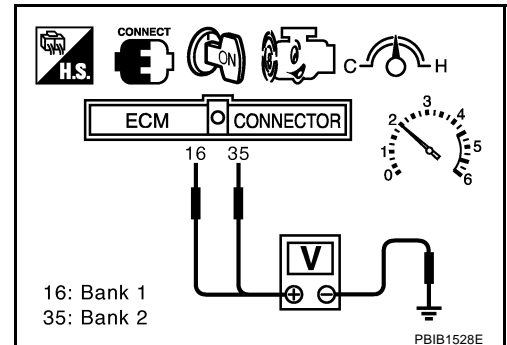

CAUTION:

- Discard any heated oxygen sensor which has been dropped from a height of more than 0.5 m (19.7 in) onto a hard surface such as a concrete floor; use a new one.

- Before installing new oxygen sensor, clean exhaust system threads using Oxygen Sensor Thread Cleaner tool J-43897-18 or J-43897-12 and approved anti-seize lubricant.

A

Removal and Installation
HEATED OXYGEN SENSOR 1

ABS00C9V

Refer to [EM-178, "EXHAUST MANIFOLD AND THREE WAY CATALYST"](#) .

EC

C

D

E

F

G

H

I

J

K

L

M

DTC P1146, P1166 HO2S2

PFP:226A0

Component Description

ABS00C9W

The heated oxygen sensor 2, after three way catalyst (manifold), monitors the oxygen level in the exhaust gas on each bank.

Even if switching characteristics of the heated oxygen sensor 1 are shifted, the air-fuel ratio is controlled to stoichiometric, by the signal from the heated oxygen sensor 2.

This sensor is made of ceramic zirconia. The zirconia generates voltage from approximately 1V in richer conditions to 0V in leaner conditions.

Under normal conditions the heated oxygen sensor 2 is not used for engine control operation.

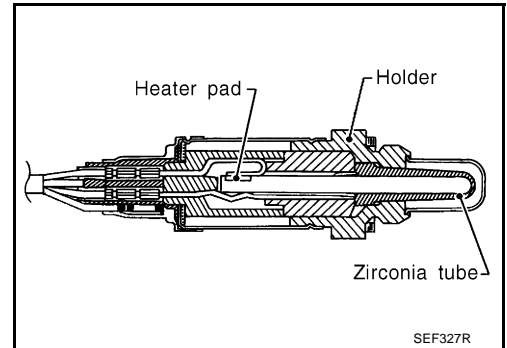

CONSULT-II Reference Value in Data Monitor Mode

ABS00C9X

Specification data are reference values.

MONITOR ITEM	CONDITION		SPECIFICATION
HO2S2 (B1) HO2S2 (B2)	<ul style="list-style-type: none"> ● Warm-up condition ● After keeping engine speed between 3,500 and 4,000 rpm for 1 minute and at idle for 1 minute under no load 	Revsing engine from idle to 3,000 rpm quickly	0 - 0.3V ↔ Approx. 0.6 - 1.0V
HO2S2 MNTR (B1) HO2S2 MNTR (B2)			LEAN ↔ RICH

On Board Diagnosis Logic

ABS00C9Y

The heated oxygen sensor 2 has a much longer switching time between rich and lean than the heated oxygen sensor 1. The oxygen storage capacity of the three way catalyst (manifold) causes the longer switching time. To judge the malfunctions of heated oxygen sensor 2, ECM monitors whether the minimum voltage of sensor is sufficiently low during the various driving condition such as fuel-cut.

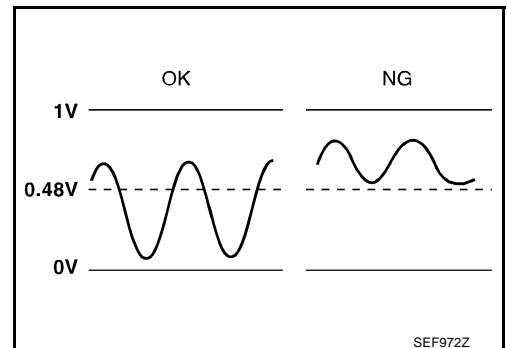

DTC No.	Trouble diagnosis name	DTC detecting condition	Possible cause
P1146 1146 (Bank 1)	Heated oxygen sensor 2 minimum voltage monitoring	The minimum voltage from the sensor is not reached to the specified voltage.	<ul style="list-style-type: none"> ● Harness or connectors (The sensor circuit is open or shorted) ● Heated oxygen sensor 2 ● Fuel pressure ● Fuel injector
P1166 1166 (Bank 2)			

DTC Confirmation Procedure

ABS00C9Z

NOTE:

If DTC confirmation Procedure has been previously conducted, always turn ignition switch OFF and wait at least 10 seconds before conducting the next test.

WITH CONSULT-II

TESTING CONDITION:

For better results, perform "DTC WORK SUPPORT" at a temperature of 0 to 30 °C (32 to 86 °F).

1. Turn ignition switch ON and select "DATA MONITOR" mode with CONSULT-II.
2. Start engine and warm it up to the normal operating temperature.
3. Turn ignition switch OFF and wait at least 10 seconds.
4. Start engine and keep the engine speed between 3,500 and 4,000 rpm for at least 1 minute under no load.
5. Let engine idle for 1 minute.
6. Make sure that "COOLAN TEMP/S" indicates more than 70°C (158°F).
If not, warm up engine and go to next step when "COOLAN TEMP/S" indication reaches to 70°C (158°F).
7. Open engine hood.
8. Select "HO2S2 (B1) P1146" or "HO2S2 (B2) P1166" of "HO2S2" in "DTC WORK SUPPORT" mode with CONSULT-II.
9. Start engine and following the instruction of CONSULT-II.

DATA MONITOR	
MONITOR	NO DTC
ENG SPEED	XXX rpm
COOLAN TEMP/S	XXX °C

SEF174Y

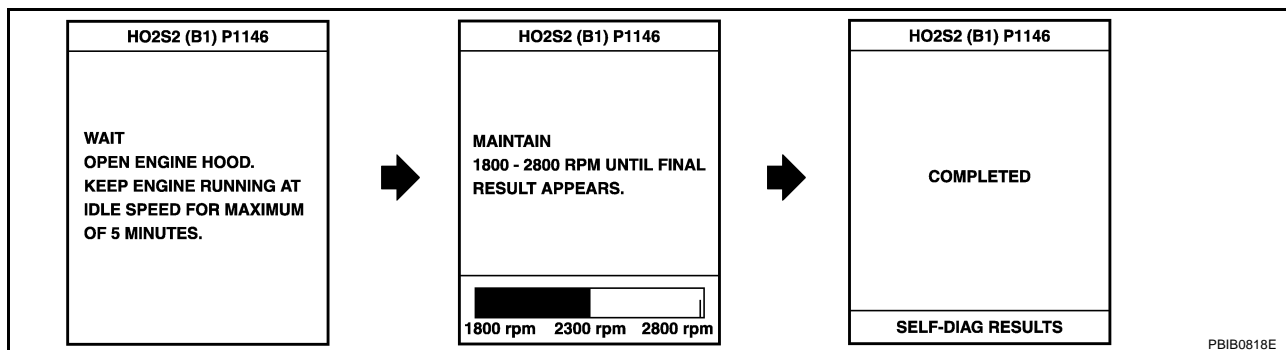

10. Make sure that "OK" is displayed after touching "SELF-DIAG RESULTS".
If "NG" is displayed, refer to [EC-1122, "Diagnostic Procedure"](#).
If "CAN NOT BE DIAGNOSED" is displayed, perform the following.
 - a. Turn ignition switch OFF and leave the vehicle in a cool place (soak the vehicle).
 - b. Return to step 1.

Overall Function Check

ABS00CA0

Use this procedure to check the overall function of the heated oxygen sensor 2 circuit. During this check, a 1st trip DTC might not be confirmed.

WITH GST

1. Start engine and warm it up to the normal operating temperature.
2. Turn ignition switch OFF and wait at least 10 seconds.
3. Start engine and keep the engine speed between 3,500 and 4,000 rpm for at least 1 minute under no load.
4. Let engine idle for 1 minute.
5. Set voltmeter probes between ECM terminal 55 [HO2S2 (B1) signal] or 74 [HO2S2 (B2) signal] and ground.

DTC P1146, P1166 HO2S2

[VK45DE]

6. Check the voltage when revving up to 4,000 rpm under no load at least 10 times.
(Depress and release accelerator pedal as soon as possible.)
The voltage should be below 0.48V at least once during this procedure.
If the voltage can be confirmed in step 6, step 7 is not necessary.
7. Keep vehicle at idling for 10 minutes, then check the voltage. Or check the voltage when coasting from 80 km/h (50 MPH) in D position with "OD" OFF.
The voltage should be below 0.48V at least once during this procedure.
8. If NG, go to [EC-1122, "Diagnostic Procedure"](#).

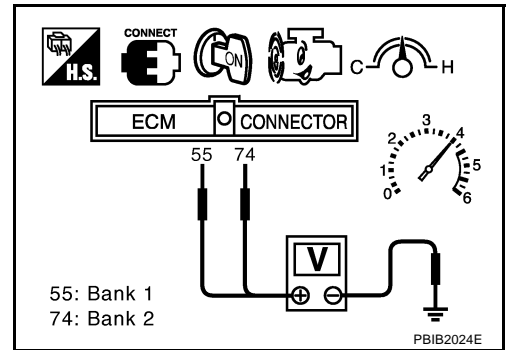

Wiring Diagram
BANK 1

EC-O2S2B1-01

— : DETECTABLE LINE FOR DTC
 — : NON-DETECTABLE LINE FOR DTC

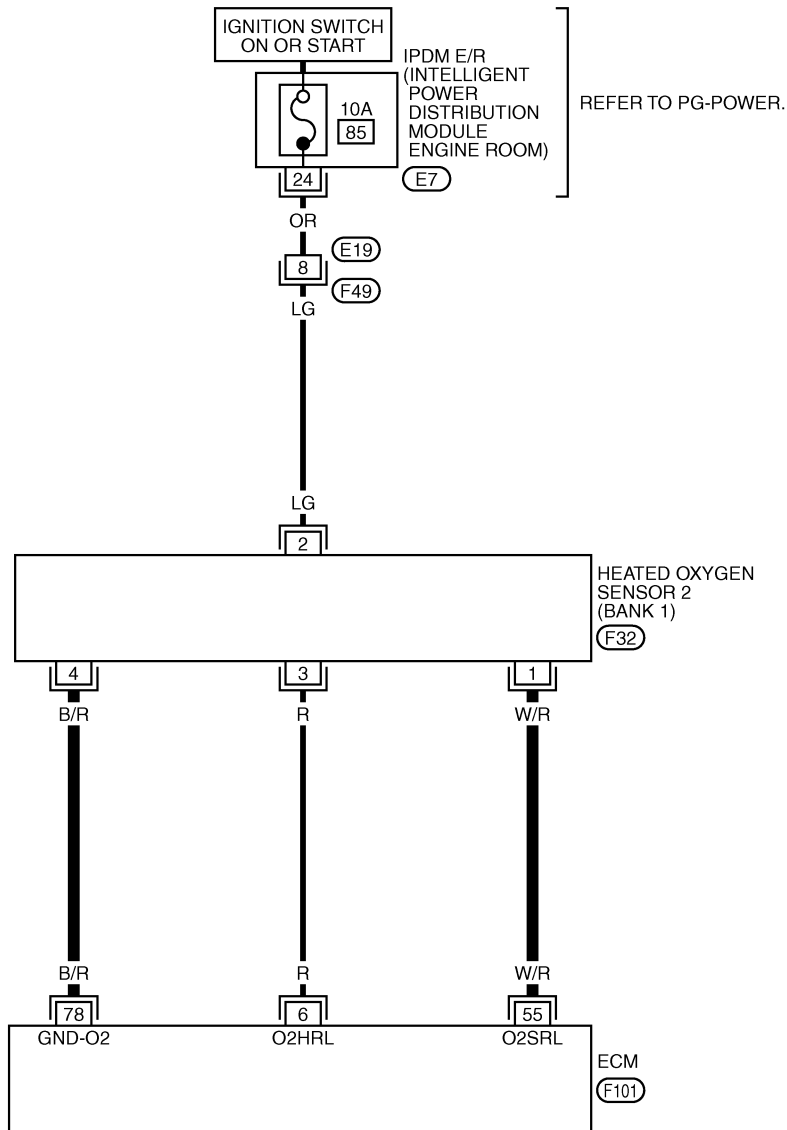

23	22	21	20	19	18	17		
32	31	30	29	28	27	26	25	24

(E7)
GY



(F32)
GY



(F49)
B

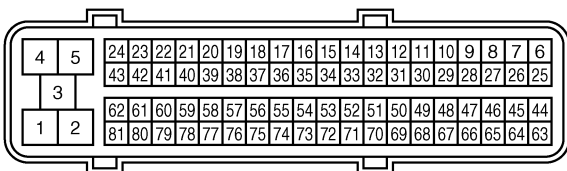

(F101)
B



DTC P1146, P1166 HO2S2

[VK45DE]

Specification data are reference values and are measured between each terminal and ground.

CAUTION:

Do not use ECM ground terminals when measuring input/output voltage. Doing so may result in damage to the ECM's transistor. Use a ground other than ECM terminals, such as the ground.

TER-MINAL NO.	WIRE COLOR	ITEM	CONDITION	DATA (DC Voltage)
55	W/R	Heated oxygen sensor 2 (bank 1)	[Engine is running] <ul style="list-style-type: none">● Warm-up condition● Revving engine from idle to 3,000 rpm quickly after the following conditions are met<ul style="list-style-type: none">– After keeping the engine speed between 3,500 and 4,000 rpm for 1 minute and at idle for 1 minute under no load	0 - Approximately 1.0V
78	B/R	Sensor ground (Heated oxygen sensor)	[Engine is running] <ul style="list-style-type: none">● Warm-up condition● Idle speed	Approximately 0V

BANK 2

EC-O2S2B2-01

— : DETECTABLE LINE FOR DTC
 — : NON-DETECTABLE LINE FOR DTC

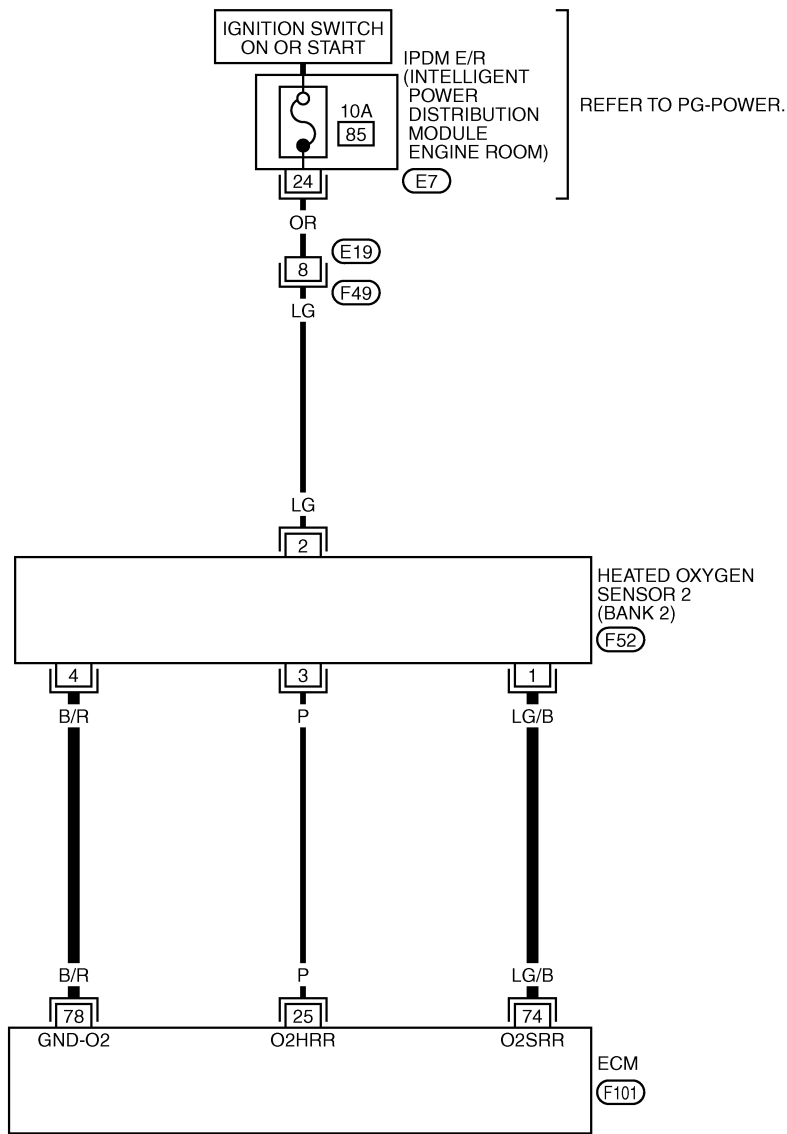

23	22	21	20	19	18	17		
32	31	30	29	28	27	26	25	24

(E7) GY H.S.

1	2	3	4
5	6	7	8

(F49) B

3	1
4	2

(F52) B

4	5	24	23	22	21	20	19	18	17	16	15	14	13	12	11	10	9	8	7	6
3		43	42	41	40	39	38	37	36	35	34	33	32	31	30	29	28	27	26	25
1	2	62	61	60	59	58	57	56	55	54	53	52	51	50	49	48	47	46	45	44
		81	80	79	78	77	76	75	74	73	72	71	70	69	68	67	66	65	64	63

(F101) B H.S.

Specification data are reference values and are measured between each terminal and ground.

CAUTION:

Do not use ECM ground terminals when measuring input/output voltage. Doing so may result in damage to the ECM's transistor. Use a ground other than ECM terminals, such as the ground.

TER-MINAL NO.	WIRE COLOR	ITEM	CONDITION	DATA (DC Voltage)
74	LG/B	Heated oxygen sensor 2 (bank 2)	<p>[Engine is running]</p> <ul style="list-style-type: none"> ● Warm-up condition ● Revving engine from idle to 3,000 rpm quickly after the following conditions are met <ul style="list-style-type: none"> - After keeping the engine speed between 3,500 and 4,000 rpm for 1 minute and at idle for 1 minute under no load 	0 - Approximately 1.0V
78	B/R	Sensor ground (Heated oxygen sensor)	<p>[Engine is running]</p> <ul style="list-style-type: none"> ● Warm-up condition ● Idle speed 	Approximately 0V

Diagnostic Procedure

ABS00CA2

1. CHECK GROUND CONNECTIONS

1. Turn ignition switch OFF.
2. Loosen and retighten three ground screws on the body.
Refer to [EC-791, "Ground Inspection"](#).

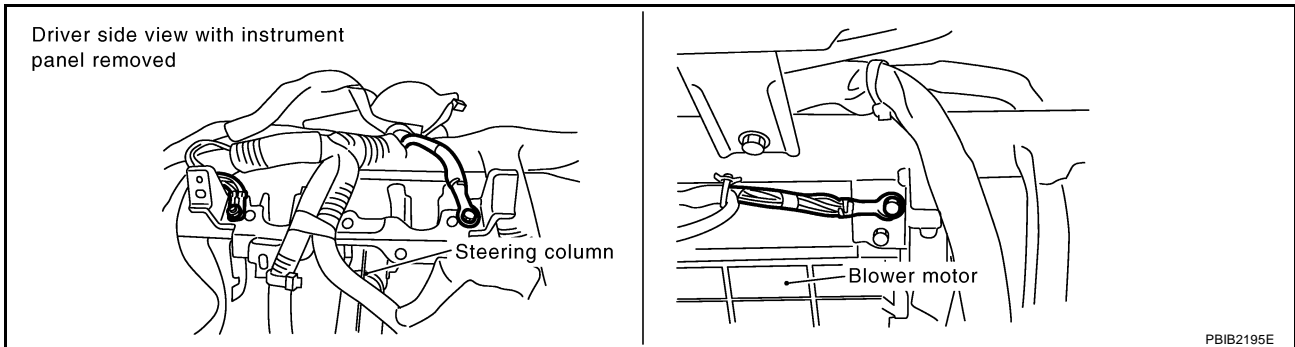

PBIB2195E

OK or NG

- OK >> GO TO 2.
- NG >> Repair or replace ground connections.

2. CLEAR THE SELF-LEARNING DATA

With CONSULT-II

1. Start engine and warm it up to normal operating temperature.
2. Select "SELF-LEARNING CONT" in "WORK SUPPORT" mode with CONSULT-II.
3. Clear the self-learning control coefficient by touching "CLEAR".
4. Run engine for at least 10 minutes at idle speed.
**Is the 1st trip DTC P0172 or P0175 detected?
Is it difficult to start engine?**

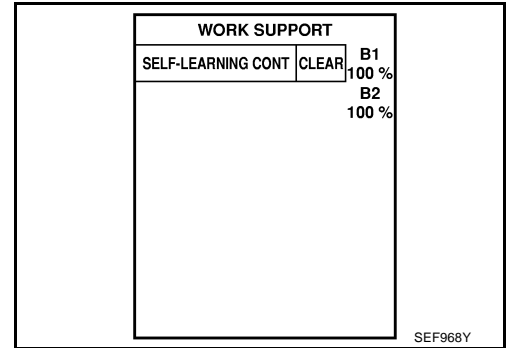

With GST

1. Start engine and warm it up to normal operating temperature.
2. Turn ignition switch OFF.
3. Disconnect mass air flow sensor harness connector, and restart and run engine for at least 5 seconds at idle speed.
4. Stop engine and reconnect mass air flow sensor harness connector.
5. Make sure DTC P0102 is displayed.
6. Erase the DTC memory. Refer to [EC-715, "HOW TO ERASE EMISSION-RELATED DIAGNOSTIC INFORMATION"](#).
7. Make sure DTC P0000 is displayed.
8. Run engine for at least 10 minutes at idle speed.
**Is the 1st trip DTC P0172 or P0175 detected?
Is it difficult to start engine?**

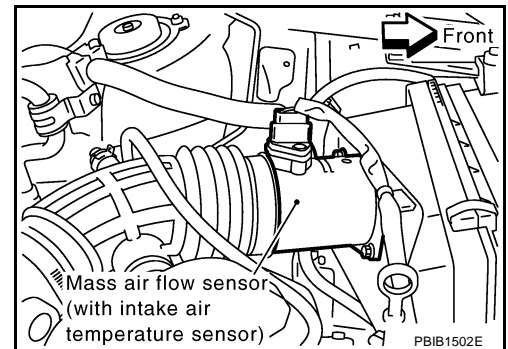

Yes or No

- Yes >> Perform trouble diagnosis for DTC P0172, P0175. Refer to [EC-923](#).
- No >> GO TO 3.

3. CHECK HO2S2 GROUND CIRCUIT FOR OPEN AND SHORT

1. Turn ignition switch OFF.
2. Disconnect heated oxygen sensor 2 harness connector.

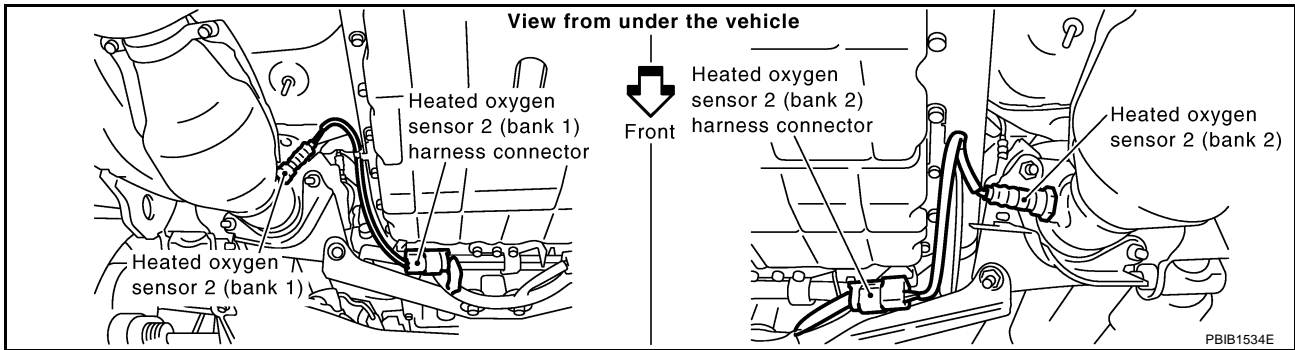

3. Disconnect ECM harness connector.
4. Check harness continuity between HO2S2 terminal 4 and ECM terminal 78. Refer to Wiring Diagram.

Continuity should exist.

5. Also check harness for short to ground and short to power.

OK or NG

OK >> GO TO 4.

NG >> Repair open circuit or short to ground or short to power in harness or connectors.

4. CHECK HO2S2 INPUT SIGNAL CIRCUIT FOR OPEN AND SHORT

1. Check harness continuity between ECM terminal and HO2S2 terminal as follows. Refer to Wiring Diagram.

DTC	Terminals		Bank
	ECM	Sensor	
P1146	55	1	1
P1166	74	1	2

Continuity should exist.

2. Check harness continuity between the following terminals and ground. Refer to Wiring Diagram.

DTC	Terminals		Bank
	ECM	Sensor	
P1146	55	1	1
P1166	74	1	2

Continuity should not exist.

3. Also check harness for short to ground and short to power.

OK or NG

OK >> GO TO 5.

NG >> Repair open circuit or short to ground or short to power in harness or connectors.

5. CHECK HEATED OXYGEN SENSOR 2

Refer to [EC-1125, "Component Inspection"](#) .

OK or NG

- OK >> GO TO 6.
- NG >> Replace malfunctioning heated oxygen sensor 2.

6. CHECK INTERMITTENT INCIDENT

Refer to [EC-784, "TROUBLE DIAGNOSIS FOR INTERMITTENT INCIDENT"](#) .

>> INSPECTION END

**Component Inspection
HEATED OXYGEN SENSOR 2**

ABS00CA3

Ⓟ With CONSULT-II

1. Turn ignition switch ON and select "DATA MONITOR" mode with CONSULT-II.
2. Start engine and warm it up to the normal operating temperature.
3. Turn ignition switch OFF and wait at least 10 seconds.
4. Start engine and keep the engine speed between 3,500 and 4,000 rpm for at least 1 minute under no load.
5. Let engine idle for 1 minute.
6. Select "FUEL INJECTION" in "ACTIVE TEST" mode, and select "HO2S2 (B1)/(B2)" as the monitor item with CONSULT-II.

DATA MONITOR	
MONITOR	NO DTC
ENG SPEED	XXX rpm
COOLAN TEMP/S	XXX °C

SEF174Y

ACTIVE TEST	
FUEL INJECTION	25 %
MONITOR	
ENG SPEED	XXX rpm
HO2S1 (B1)	XXX V
HO2S2 (B1)	XXX V
HO2S1 MNTR (B1)	RICH
HO2S2 MNTR (B1)	RICH

SEF662Y

7. Check "HO2S2 (B1)/(B2)" at idle speed when adjusting "FUEL INJECTION" to ±25%.

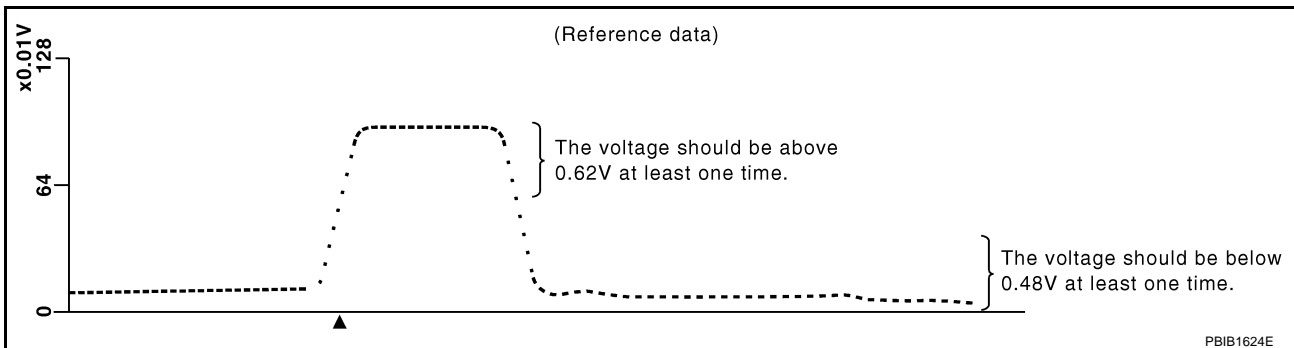

"HO2S2 (B1)/(B2)" should be above 0.62V at least once when the "FUEL INJECTION" is +25%.
 "HO2S2 (B1)/(B2)" should be below 0.48V at least once when the "FUEL INJECTION" is -25%.

CAUTION:

- Discard any heated oxygen sensor which has been dropped from a height of more than 0.5 m (19.7 in) onto a hard surface such as a concrete floor; use a new one.

- Before installing new oxygen sensor, clean exhaust system threads using Oxygen Sensor Thread Cleaner tool J-43897-18 or J-43897-12 and approved anti-seize lubricant.

⊗ **Without CONSULT-II**

1. Start engine and warm it up to the normal operating temperature.
2. Turn ignition switch OFF and wait at least 10 seconds.
3. Start engine and keep the engine speed between 3,500 and 4,000 rpm for at least 1 minute under no load.
4. Let engine idle for 1 minute.
5. Set voltmeter probes between ECM terminal 55 [HO2S2 (B1) signal] or 74 [HO2S2 (B2) signal] and ground.
6. Check the voltage when revving up to 4,000 rpm under no load at least 10 times.
(Depress and release accelerator pedal as soon as possible.)
The voltage should be above 0.62V at least once during this procedure.
If the voltage is above 0.62V at step 6, step 7 is not necessary.
7. Keep vehicle at idling for 10 minutes, then check voltage. Or check the voltage when coasting from 80 km/h (50 MPH) in D position with "OD" OFF.
The voltage should be below 0.48V at least once during this procedure.
8. If NG, replace heated oxygen sensor 2.

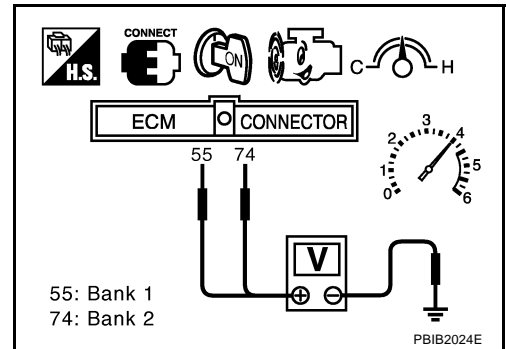

CAUTION:

- Discard any heated oxygen sensor which has been dropped from a height of more than 0.5 m (19.7 in) onto a hard surface such as a concrete floor; use a new one.
- Before installing new oxygen sensor, clean exhaust system threads using Oxygen Sensor Thread Cleaner tool J-43897-18 or J-43897-12 and approved anti-seize lubricant.

Removal and Installation HEATED OXYGEN SENSOR 2

ABS00CA4

Refer to [EM-178, "EXHAUST MANIFOLD AND THREE WAY CATALYST"](#) .

DTC P1147, P1167 HO2S2

PF2:226A0

Component Description

ABS00CA5

The heated oxygen sensor 2, after three way catalyst (manifold), monitors the oxygen level in the exhaust gas on each bank.

Even if switching characteristics of the heated oxygen sensor 1 are shifted, the air-fuel ratio is controlled to stoichiometric, by the signal from the heated oxygen sensor 2.

This sensor is made of ceramic zirconia. The zirconia generates voltage from approximately 1V in richer conditions to 0V in leaner conditions.

Under normal conditions the heated oxygen sensor 2 is not used for engine control operation.

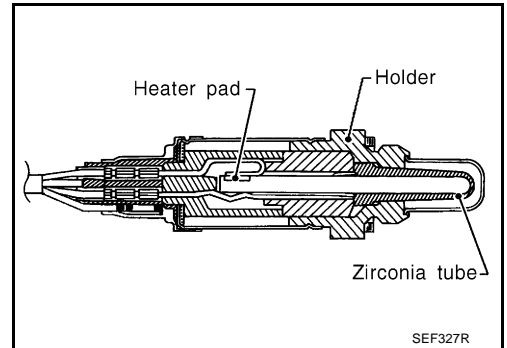

CONSULT-II Reference Value in Data Monitor Mode

ABS00CA6

Specification data are reference values.

MONITOR ITEM	CONDITION		SPECIFICATION
HO2S2 (B1) HO2S2 (B2)	<ul style="list-style-type: none"> Warm-up condition After keeping engine speed between 3,500 and 4,000 rpm for 1 minute and at idle for 1 minute under no load 	Revving engine from idle to 3,000 rpm quickly	0 - 0.3V ↔ Approx. 0.6 - 1.0V
HO2S2 MNTR (B1) HO2S2 MNTR (B2)			LEAN ↔ RICH

On Board Diagnosis Logic

ABS00CA7

The heated oxygen sensor 2 has a much longer switching time between rich and lean than the heated oxygen sensor 1. The oxygen storage capacity of the three way catalyst (manifold) causes the longer switching time. To judge the malfunctions of heated oxygen sensor 2, ECM monitors whether the maximum voltage of the sensor is sufficiently high during the various driving condition such as fuel-cut.

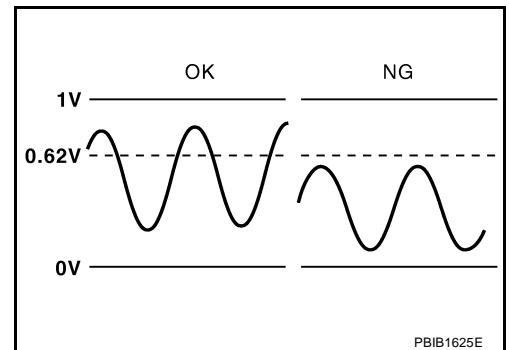

DTC No.	Trouble diagnosis name	DTC detecting condition	Possible cause
P1147 1147 (Bank 1)	Heated oxygen sensor 2 maximum voltage monitoring	The maximum voltage from the sensor is not reached to the specified voltage.	<ul style="list-style-type: none"> Harness or connectors (The sensor circuit is open or shorted) Heated oxygen sensor 2 Fuel pressure Fuel injector Intake air leaks
P1167 1167 (Bank 2)			

DTC Confirmation Procedure

NOTE:

If DTC confirmation Procedure has been previously conducted, always turn ignition switch OFF and wait at least 10 seconds before conducting the next test.

WITH CONSULT-II

TESTING CONDITION:

For better results, perform "DTC WORK SUPPORT" at a temperature of 0 to 30 °C (32 to 86 °F).

1. Turn ignition switch ON and select "DATA MONITOR" mode with CONSULT-II.
2. Start engine and warm it up to the normal operating temperature.
3. Turn ignition switch OFF and wait at least 10 seconds.
4. Start engine and keep the engine speed between 3,500 and 4,000 rpm for at least 1 minute under no load.
5. Let engine idle for 1 minute.
6. Make sure that "COOLAN TEMP/S" indicates more than 70°C (158°F).
If not, warm up engine and go to next step when "COOLAN TEMP/S" indication reaches to 70°C (158°F).
7. Open engine hood.
8. Select "HO2S2 (B1) P1147" or "HO2S2 (B2) P1167" of "HO2S2" in "DTC WORK SUPPORT" mode with CONSULT-II.
9. Start engine and following the instruction of CONSULT-II.

DATA MONITOR	
MONITOR	NO DTC
ENG SPEED	XXX rpm
COOLAN TEMP/S	XXX °C

SEF174Y

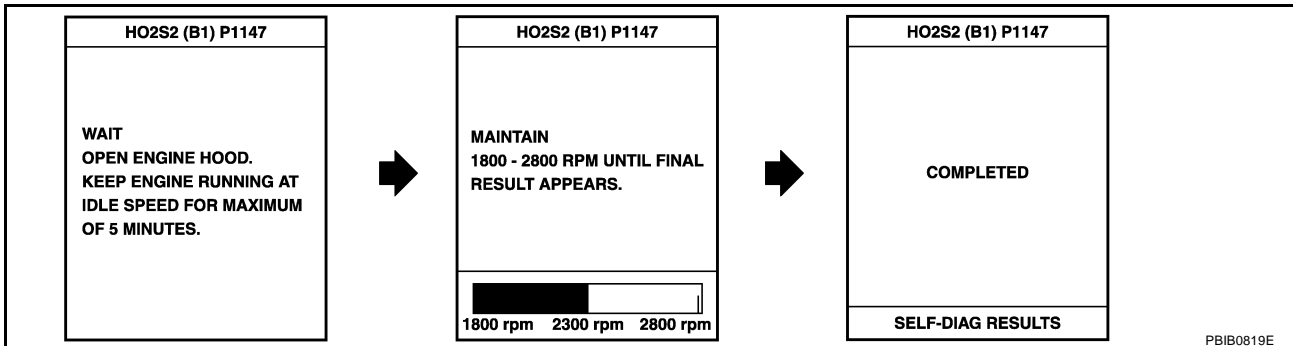

10. Make sure that "OK" is displayed after touching "SELF-DIAG RESULTS".
If "NG" is displayed, refer to [EC-1133, "Diagnostic Procedure"](#).
If "CAN NOT BE DIAGNOSED" is displayed, perform the following.
 - a. Turn ignition switch OFF and leave the vehicle in a cool place (soak the vehicle).
 - b. Return to step 1.

Overall Function Check

Use this procedure to check the overall function of the heated oxygen sensor 2 circuit. During this check, a 1st trip DTC might not be confirmed.

WITH GST

1. Start engine and warm it up to the normal operating temperature.
2. Turn ignition switch OFF and wait at least 10 seconds.
3. Start engine and keep the engine speed between 3,500 and 4,000 rpm for at least 1 minute under no load.
4. Let engine idle for 1 minute.
5. Set voltmeter probes between ECM terminal 55 [HO2S2 (B1) signal] or 74 [HO2S2 (B2) signal] and ground.

DTC P1147, P1167 HO2S2

[VK45DE]

6. Check the voltage when revving up to 4,000 rpm under no load at least 10 times.
(Depress and release accelerator pedal as soon as possible.)
The voltage should be above 0.62V at least once during this procedure.
If the voltage can be confirmed in step 6, step 7 is not necessary.
7. Keep vehicle at idling for 10 minutes, then check the voltage. Or check the voltage when coasting from 80 km/h (50 MPH) in D position with "OD" OFF.
The voltage should be above 0.62V at least once during this procedure.
8. If NG, go to [EC-1133, "Diagnostic Procedure"](#).

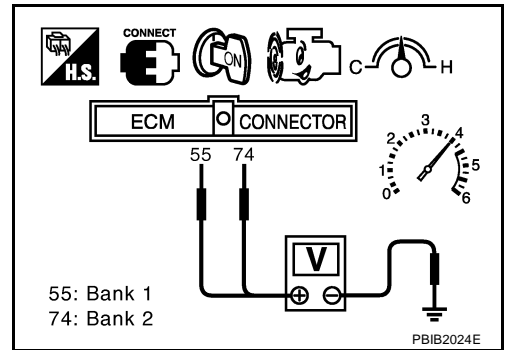

A
EC
C
D
E
F
G
H
I
J
K
L
M

Wiring Diagram
BANK 1

EC-O2S2B1-01

— : DETECTABLE LINE FOR DTC
 — : NON-DETECTABLE LINE FOR DTC

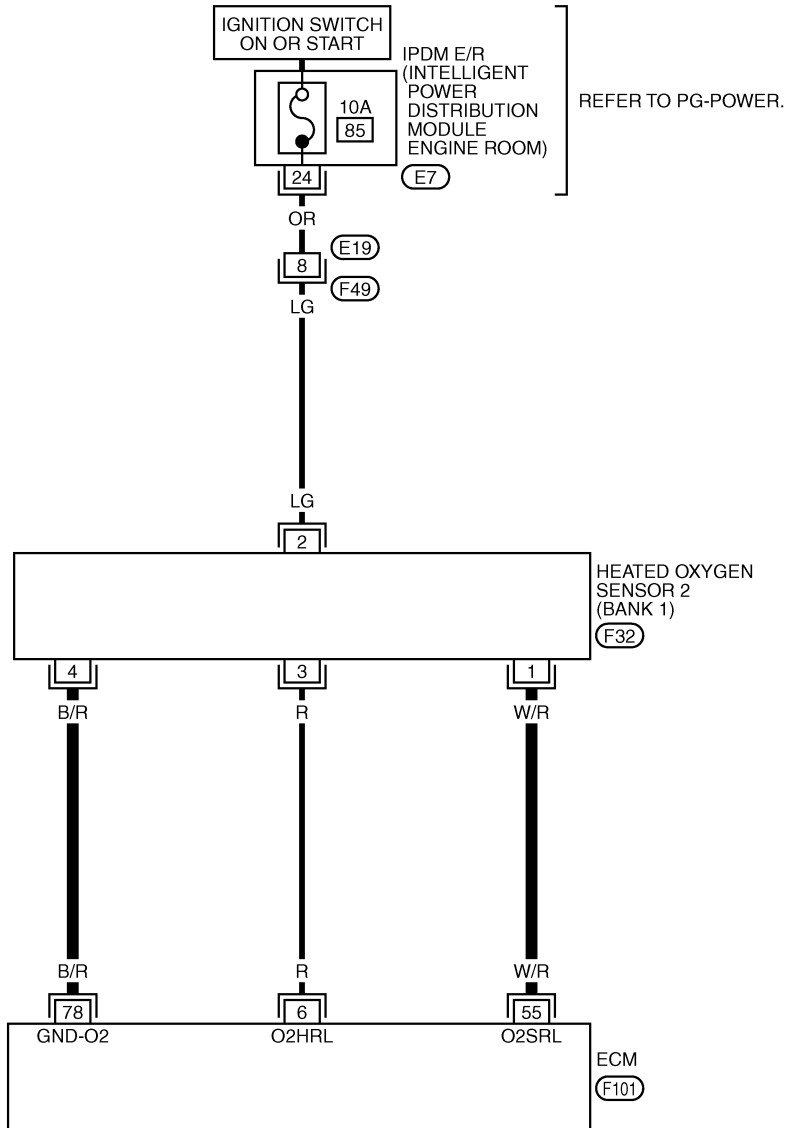

23	22	21	20	19	18	17		
32	31	30	29	28	27	26	25	24

E7
GY



3	1
4	2

F32
GY

1	2	3	4
5	6	7	8

F49
B

4	5	24	23	22	21	20	19	18	17	16	15	14	13	12	11	10	9	8	7	6																			
3	32	31	30	29	28	27	26	25	24	43	42	41	40	39	38	37	36	35	34	33	32	31	30	29	28	27	26	25											
1	2	62	61	60	59	58	57	56	55	54	53	52	51	50	49	48	47	46	45	44	81	80	79	78	77	76	75	74	73	72	71	70	69	68	67	66	65	64	63

F101
B



DTC P1147, P1167 HO2S2

[VK45DE]

Specification data are reference values and are measured between each terminal and ground.

CAUTION:

Do not use ECM ground terminals when measuring input/output voltage. Doing so may result in damage to the ECM's transistor. Use a ground other than ECM terminals, such as the ground.

TER-MINAL NO.	WIRE COLOR	ITEM	CONDITION	DATA (DC Voltage)
55	W/R	Heated oxygen sensor 2 (bank 1)	[Engine is running] <ul style="list-style-type: none"> ● Warm-up condition ● Revving engine from idle to 3,000 rpm quickly after the following conditions are met <ul style="list-style-type: none"> – After keeping the engine speed between 3,500 and 4,000 rpm for 1 minute and at idle for 1 minute under no load 	0 - Approximately 1.0V
78	B/R	Sensor ground (Heated oxygen sensor)	[Engine is running] <ul style="list-style-type: none"> ● Warm-up condition ● Idle speed 	Approximately 0V

A
EC
C
D
E
F
G
H
I
J
K
L
M

DTC P1147, P1167 HO2S2

[VK45DE]

BANK 2

EC-O2S2B2-01

— : DETECTABLE LINE FOR DTC
 — : NON-DETECTABLE LINE FOR DTC

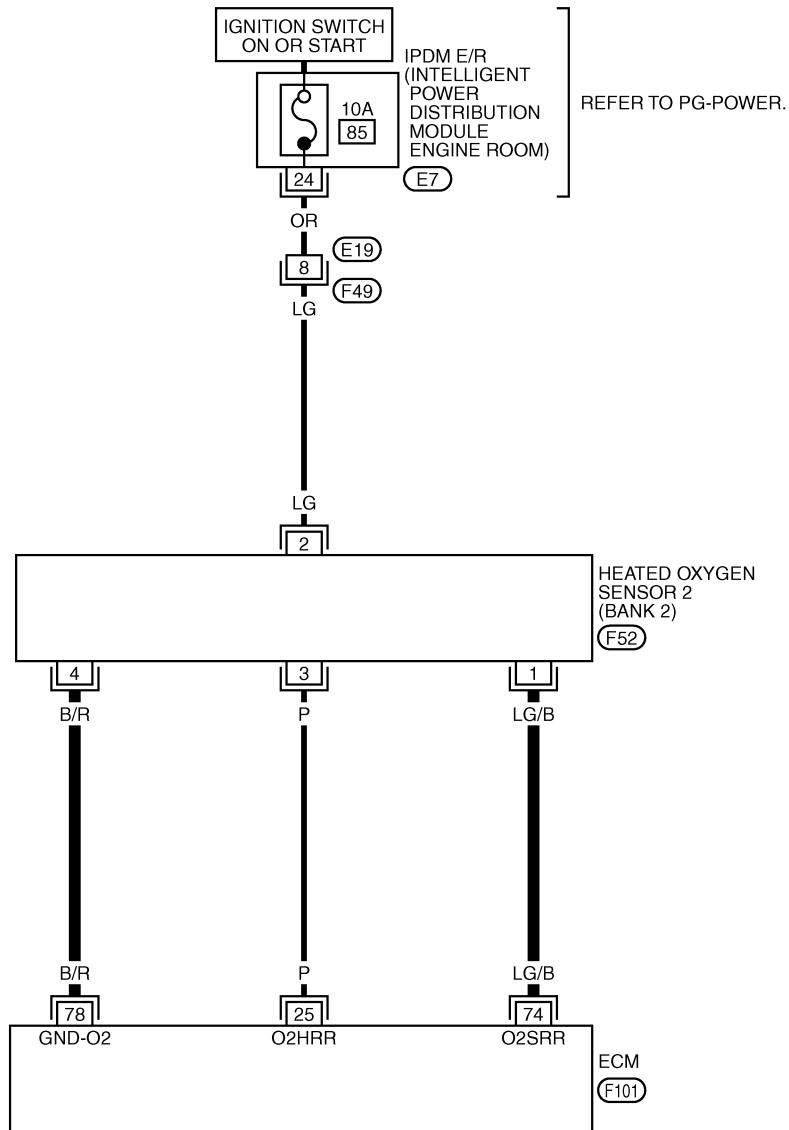

23	22	21	20	19	18	17		
32	31	30	29	28	27	26	25	24

(E7) GY

H.S.

1	2	3	4
5	6	7	8

(F49) B

3	1
4	2

(F52) B

4	5	24	23	22	21	20	19	18	17	16	15	14	13	12	11	10	9	8	7	6
3		43	42	41	40	39	38	37	36	35	34	33	32	31	30	29	28	27	26	25
		62	61	60	59	58	57	56	55	54	53	52	51	50	49	48	47	46	45	44
1	2	81	80	79	78	77	76	75	74	73	72	71	70	69	68	67	66	65	64	63

(F101) B

H.S.

TBWM0231E

Specification data are reference values and are measured between each terminal and ground.

CAUTION:

Do not use ECM ground terminals when measuring input/output voltage. Doing so may result in damage to the ECM's transistor. Use a ground other than ECM terminals, such as the ground.

TER-MINAL NO.	WIRE COLOR	ITEM	CONDITION	DATA (DC Voltage)
74	LG/B	Heated oxygen sensor 2 (bank 2)	<p>[Engine is running]</p> <ul style="list-style-type: none"> ● Warm-up condition ● Revving engine from idle to 3,000 rpm quickly after the following conditions are met – After keeping the engine speed between 3,500 and 4,000 rpm for 1 minute and at idle for 1 minute under no load 	0 - Approximately 1.0V
78	B/R	Sensor ground (Heated oxygen sensor)	<p>[Engine is running]</p> <ul style="list-style-type: none"> ● Warm-up condition ● Idle speed 	Approximately 0V

Diagnostic Procedure

ABS00CAB

1. CHECK GROUND CONNECTIONS

1. Turn ignition switch OFF.
2. Loosen and retighten three ground screws on the body. Refer to [EC-791, "Ground Inspection"](#).

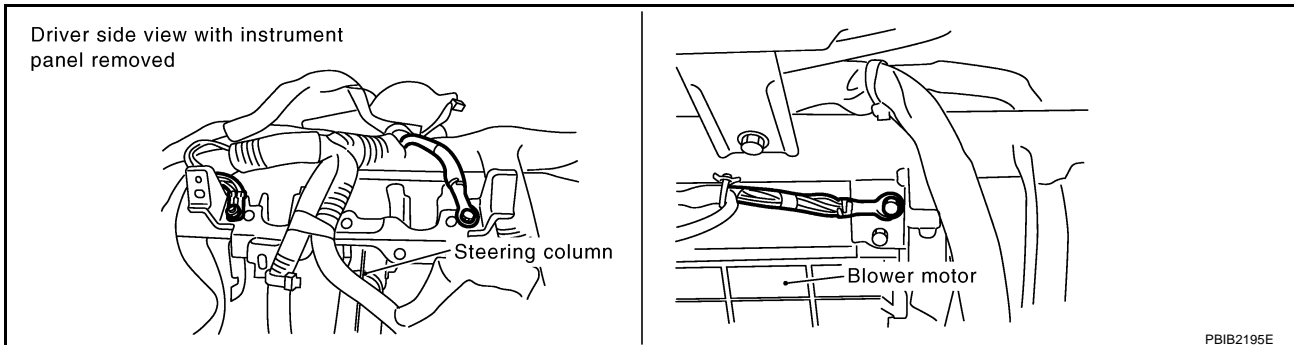

OK or NG

- OK >> GO TO 2.
- NG >> Repair or replace ground connections.

2. CLEAR THE SELF-LEARNING DATA

With CONSULT-II

1. Start engine and warm it up to normal operating temperature.
2. Select "SELF-LEARNING CONT" in "WORK SUPPORT" mode with CONSULT-II.
3. Clear the self-learning control coefficient by touching "CLEAR".
4. Run engine for at least 10 minutes at idle speed.
Is the 1st trip DTC P0171 or P0174 detected?
Is it difficult to start engine?

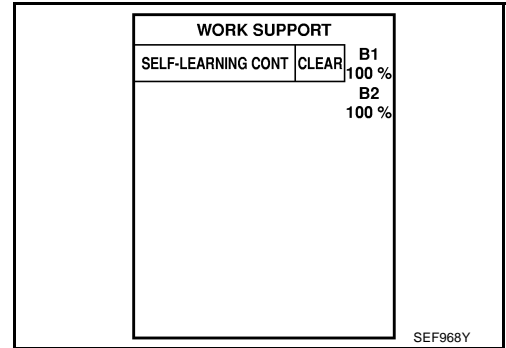

With GST

1. Start engine and warm it up to normal operating temperature.
2. Turn ignition switch OFF.
3. Disconnect mass air flow sensor harness connector, and restart and run engine for at least 5 seconds at idle speed.
4. Stop engine and reconnect mass air flow sensor harness connector.
5. Make sure DTC P0102 is displayed.
6. Erase the DTC memory. Refer to [EC-715, "HOW TO ERASE EMISSION-RELATED DIAGNOSTIC INFORMATION"](#).
7. Make sure DTC P0000 is displayed.
8. Run engine for at least 10 minutes at idle speed.
Is the 1st trip DTC P0171 or P0174 detected?
Is it difficult to start engine?

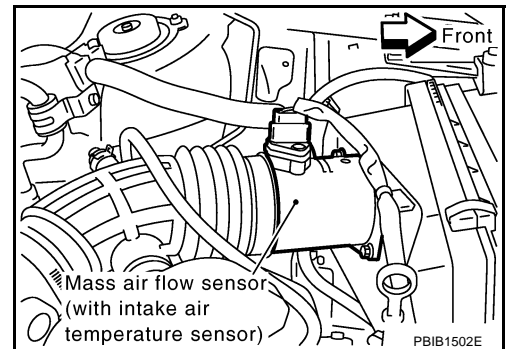

Yes or No

- Yes >> Perform trouble diagnosis for DTC P0171, P0174. Refer to [EC-914](#).
- No >> GO TO 3.

3. CHECK HO2S2 GROUND CIRCUIT FOR OPEN AND SHORT

1. Turn ignition switch OFF.
2. Disconnect heated oxygen sensor 2 harness connector.

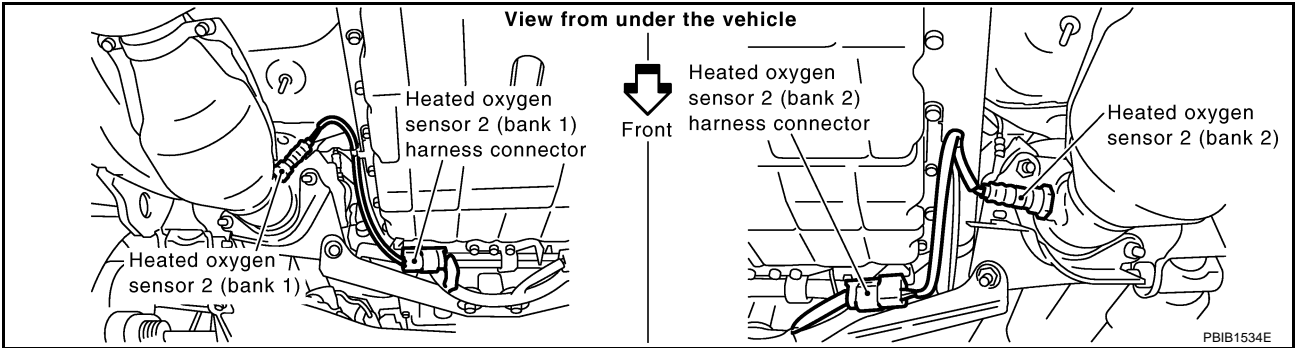

3. Disconnect ECM harness connector.
4. Check harness continuity between HO2S2 terminal 4 and ECM terminal 78. Refer to Wiring Diagram.

Continuity should exist.

5. Also check harness for short to ground and short to power.

OK or NG

OK >> GO TO 4.

NG >> Repair open circuit or short to ground or short to power in harness or connectors.

4. CHECK HO2S2 INPUT SIGNAL CIRCUIT FOR OPEN AND SHORT

1. Check harness continuity between ECM terminal and HO2S2 terminal as follows. Refer to Wiring Diagram.

DTC	Terminals		Bank
	ECM	Sensor	
P1147	55	1	1
P1167	74	1	2

Continuity should exist.

2. Check harness continuity between the following terminals and ground. Refer to Wiring Diagram.

DTC	Terminals		Bank
	ECM	Sensor	
P1147	55	1	1
P1167	74	1	2

Continuity should not exist.

3. Also check harness for short to ground and short to power.

OK or NG

OK >> GO TO 5.

NG >> Repair open circuit or short to ground or short to power in harness or connectors.

5. CHECK HEATED OXYGEN SENSOR 2

Refer to [EC-1136, "Component Inspection"](#) .

OK or NG

- OK >> GO TO 6.
- NG >> Replace malfunctioning heated oxygen sensor 2.

6. CHECK INTERMITTENT INCIDENT

Refer to [EC-784, "TROUBLE DIAGNOSIS FOR INTERMITTENT INCIDENT"](#) .

>> INSPECTION END

Component Inspection HEATED OXYGEN SENSOR 2

ABS00CAC

 With CONSULT-II

1. Turn ignition switch ON and select "DATA MONITOR" mode with CONSULT-II.
2. Start engine and warm it up to the normal operating temperature.
3. Turn ignition switch OFF and wait at least 10 seconds.
4. Start engine and keep the engine speed between 3,500 and 4,000 rpm for at least 1 minute under no load.
5. Let engine idle for 1 minute.

DATA MONITOR	
MONITOR	NO DTC
ENG SPEED	XXX rpm
COOLANT TEMP/S	XXX °C

SEF174Y

6. Select "FUEL INJECTION" in "ACTIVE TEST" mode, and select "HO2S2 (B1)/(B2)" as the monitor item with CONSULT-II.

ACTIVE TEST	
FUEL INJECTION	25 %
MONITOR	
ENG SPEED	XXX rpm
HO2S1 (B1)	XXX V
HO2S2 (B1)	XXX V
HO2S1 MNTR (B1)	RICH
HO2S2 MNTR (B1)	RICH

SEF662Y

7. Check "HO2S2 (B1)/(B2)" at idle speed when adjusting "FUEL INJECTION" to $\pm 25\%$.

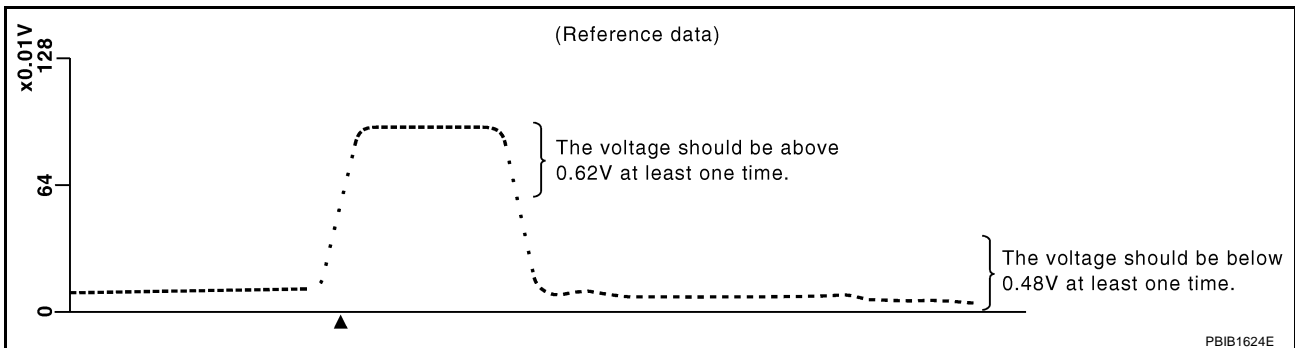

"HO2S2 (B1)/(B2)" should be above 0.62V at least once when the "FUEL INJECTION" is +25%.

"HO2S2 (B1)/(B2)" should be below 0.48V at least once when the "FUEL INJECTION" is -25%.

CAUTION:

- Discard any heated oxygen sensor which has been dropped from a height of more than 0.5 m (19.7 in) onto a hard surface such as a concrete floor; use a new one.

- Before installing new oxygen sensor, clean exhaust system threads using Oxygen Sensor Thread Cleaner tool J-43897-18 or J-43897-12 and approved anti-seize lubricant.

⊗ Without CONSULT-II

1. Start engine and warm it up to the normal operating temperature.
2. Turn ignition switch OFF and wait at least 10 seconds.
3. Start engine and keep the engine speed between 3,500 and 4,000 rpm for at least 1 minute under no load.
4. Let engine idle for 1 minute.
5. Set voltmeter probes between ECM terminal 55 [HO2S2 (B1) signal] or 74 [HO2S2 (B2) signal] and ground.
6. Check the voltage when revving up to 4,000 rpm under no load at least 10 times.
(Depress and release accelerator pedal as soon as possible.)
The voltage should be above 0.62V at least once during this procedure.
If the voltage is above 0.62V at step 6, step 7 is not necessary.
7. Keep vehicle at idling for 10 minutes, then check voltage. Or check the voltage when coasting from 80 km/h (50 MPH) in D position with "OD" OFF.
The voltage should be below 0.48V at least once during this procedure.
8. If NG, replace heated oxygen sensor 2.

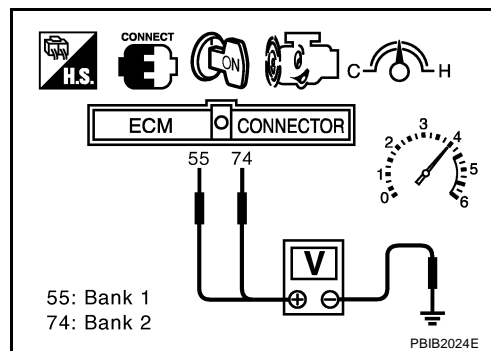

CAUTION:

- Discard any heated oxygen sensor which has been dropped from a height of more than 0.5 m (19.7 in) onto a hard surface such as a concrete floor; use a new one.
- Before installing new oxygen sensor, clean exhaust system threads using Oxygen Sensor Thread Cleaner tool J-43897-18 or J-43897-12 and approved anti-seize lubricant.

Removal and Installation HEATED OXYGEN SENSOR 2

ABS00CAD

Refer to [EM-178, "EXHAUST MANIFOLD AND THREE WAY CATALYST"](#)

DTC P1148, P1168 CLOSED LOOP CONTROL

PFP:22690

On Board Diagnosis Logic

ABS00CAE

These self-diagnoses have the one trip detection logic.

DTC No.	Trouble diagnosis name	DTC detecting condition	Possible cause
P1148 1148 (Bank 1)	Closed loop control function	The closed loop control function for bank 1 does not operate even when vehicle is driving in the specified condition.	<ul style="list-style-type: none"> ● The heated oxygen sensor 1 circuit is open or shorted. ● Heated oxygen sensor 1 ● Heated oxygen sensor heater
P1168 1168 (Bank 2)		The closed loop control function for bank 2 does not operate even when vehicle is driving in the specified condition.	

DTC Confirmation Procedure

ABS00CAF

CAUTION:

Always drive vehicle at a safe speed.

NOTE:

If DTC Confirmation Procedure has been previously conducted, always turn ignition switch OFF and wait at least 10 seconds before conducting the next test.

TESTING CONDITION:

- Do not raise engine speed above 3,000 rpm during the DTC Confirmation Procedure. If the engine speed limit is exceeded, retry the procedure from step 2.
- Before performing the following procedure, confirm that battery voltage is more than 11V at idle.

WITH CONSULT-II

1. Start engine and warm it up to normal operating temperature.
2. Select "DATA MONITOR" mode with CONSULT-II.
3. Hold engine speed at 2,000 rpm and check one of the following.
 - "HO2S1 (B1)/(B2)" voltage should go above 0.70V at least once.
 - "HO2S1 (B1)/(B2)" voltage should go below 0.21V at least once. If the check result is NG, perform [EC-1139, "Diagnostic Procedure"](#).
 If the check result is OK, perform the following step.
4. Let engine idle at least 5 minutes.
5. Maintain the following condition at least 50 consecutive seconds.

B/FUEL SCHDL	4.0 msec or more
ENG SPEED	More than 1,300 rpm
Selector lever	Suitable position
VHCL SPEED SE	More than 70 km/h (43 MPH)

DATA MONITOR	
MONITOR	NO DTC
ENG SPEED	XXX rpm
COOLAN TEMP/S	XXX °C
HO2S1 (B1)	XXX V
HO2S1 (B2)	XXX V

SEC011C

During this test, P0132 and/or P0152 may be displayed on CONSULT-II screen.

6. If DTC is detected, go to [EC-1139, "Diagnostic Procedure"](#).

Overall Function Check

ABS00CAG

Use this procedure to check the overall function of the closed loop control. During this check, a DTC might not be confirmed.

WITH GST

1. Start engine and warm it up to normal operating temperature.
2. Set voltmeter probes between ECM terminal 16 [HO2S1 (B1) signal] or 35 [HO2S1 (B2) signal] and ground.
3. Check the following with engine speed held at 2,000 rpm constant under no load.
 - The voltage should go above 0.70V at least once.
 - The voltage should go below 0.21V at least once.
4. If NG, go to [EC-1139, "Diagnostic Procedure"](#) .

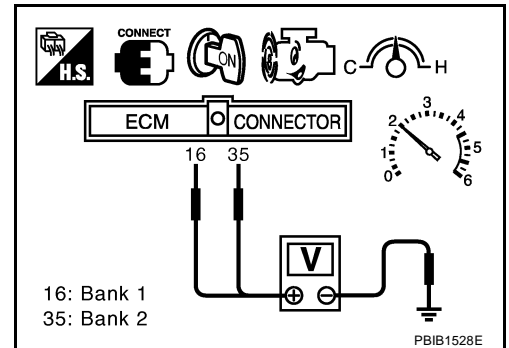

Diagnostic Procedure

ABS00CAH

Perform trouble diagnosis for DTC P0133, P0153. Refer to [EC-878, "Diagnostic Procedure"](#) .

DTC P1211 TCS CONTROL UNIT

PFP:47850

Description

ABS00CAI

The malfunction information related to TCS is transferred through the CAN communication line from “ABS actuator and electric unit (control unit)” to ECM.

Be sure to erase the malfunction information such as DTC not only for “ABS actuator and electric unit (control unit)” but also for ECM after TCS related repair.

On Board Diagnosis Logic

ABS00CAJ

Freeze frame data is not stored in the ECM for this self-diagnosis. The MIL will not light up for this self-diagnosis.

DTC No.	Trouble diagnosis name	DTC detecting condition	Possible cause
P1211 1211	TCS control unit	ECM receives a malfunction information from “ABS actuator electric unit (control unit)”	<ul style="list-style-type: none"> ● ABS actuator and electric unit (control unit) ● TCS related parts

DTC Confirmation Procedure

ABS00CAK

TESTING CONDITION:

Before performing the following procedure, confirm that battery voltage is more than 10.5V at idle.

WITH CONSULT-II

1. Turn ignition switch ON.
2. Select “DATA MONITOR” mode with CONSULT-II.
3. Start engine and let it idle for at least 60 seconds.
4. If 1st trip DTC is detected, go to [EC-1140, "Diagnostic Procedure"](#).

DATA MONITOR	
MONITOR	NO DTC
ENG SPEED	XXX rpm

SEF058Y

WITH GST

Follow the procedure “WITH CONSULT-II” above.

Diagnostic Procedure

ABS00CAL

Go to [BRC-12, "TROUBLE DIAGNOSIS"](#).

DTC P1212 TCS COMMUNICATION LINE

PFP:47850

Description

ABS00CAM

NOTE:

If DTC P1212 is displayed with DTC U1000 or U1001, first perform the trouble diagnosis for DTC U1000, U1001. Refer to [EC-792, "DTC U1000, U1001 CAN COMMUNICATION LINE"](#).

This CAN communication line is used to control the smooth engine operation during the TCS operation. Pulse signals are exchanged between ECM and "ABS actuator and electric unit (control unit)".

Be sure to erase the malfunction information such as DTC not only for "ABS actuator and electric unit (control unit)" but also for ECM after TCS related repair.

On Board Diagnosis Logic

ABS00CAN

Freeze frame data is not stored in the ECM for this self-diagnosis. The MIL will not light up for this self-diagnosis.

DTC No.	Trouble diagnosis name	DTC detecting condition	Possible cause
P1212 1212	TCS communication line	ECM can not receive the information from "ABS actuator and electric unit (control unit)" continuously.	<ul style="list-style-type: none"> ● Harness or connectors (The CAN communication line is open or shorted.) ● ABS actuator and electric unit (control unit) ● Dead (Weak) battery

DTC Confirmation Procedure

ABS00CA0

TESTING CONDITION:

Before performing the following procedure, confirm that battery voltage is more than 10.5V at idle.

WITH CONSULT-II

1. Turn ignition switch ON.
2. Select "DATA MONITOR" mode with CONSULT-II.
3. Start engine and let it idle for at least 10 seconds.
4. If a 1st trip DTC is detected, go to [EC-1141, "Diagnostic Procedure"](#).

DATA MONITOR	
MONITOR	NO DTC
ENG SPEED	XXX rpm

SEF058Y

WITH GST

Follow the procedure "WITH CONSULT-II" above.

Diagnostic Procedure

ABS00CAP

1. CHECK "ABS ACTUATOR AND ELECTRIC UNIT (CONTROL UNIT)" FUNCTION

Refer to [BRC-12, "TROUBLE DIAGNOSIS"](#).

>> INSPECTION END

DTC P1217 ENGINE OVER TEMPERATURE

PFP:00000

Description SYSTEM DESCRIPTION

ABS00CAQ

NOTE:

If DTC P1217 is displayed with DTC U1000 or U1001, first perform the trouble diagnosis for DTC U1000, U1001. Refer to [EC-792, "DTC U1000, U1001 CAN COMMUNICATION LINE"](#).

Cooling Fan Control

Sensor	Input signal to ECM	ECM function	Actuator
Crankshaft position sensor (POS) Camshaft position sensor (PHASE)	Engine speed*1	Cooling fan control	IPDM E/R (Cooling fan relay)
Battery	Battery voltage*1		
Wheel sensor*2	Vehicle speed		
Engine coolant temperature sensor	Engine coolant temperature		
Air conditioner switch	Air conditioner ON signal*2		
Refrigerant pressure sensor	Refrigerant pressure		

*1: The ECM determines the start signal status by the signals of engine speed and battery voltage.

*2: This signal is sent to ECM through CAN communication line.

The ECM controls the cooling fan corresponding to the vehicle speed, engine coolant temperature, refrigerant pressure, and air conditioner ON signal. The control system has 2-step control [HIGH/OFF].

Cooling Fan Operation

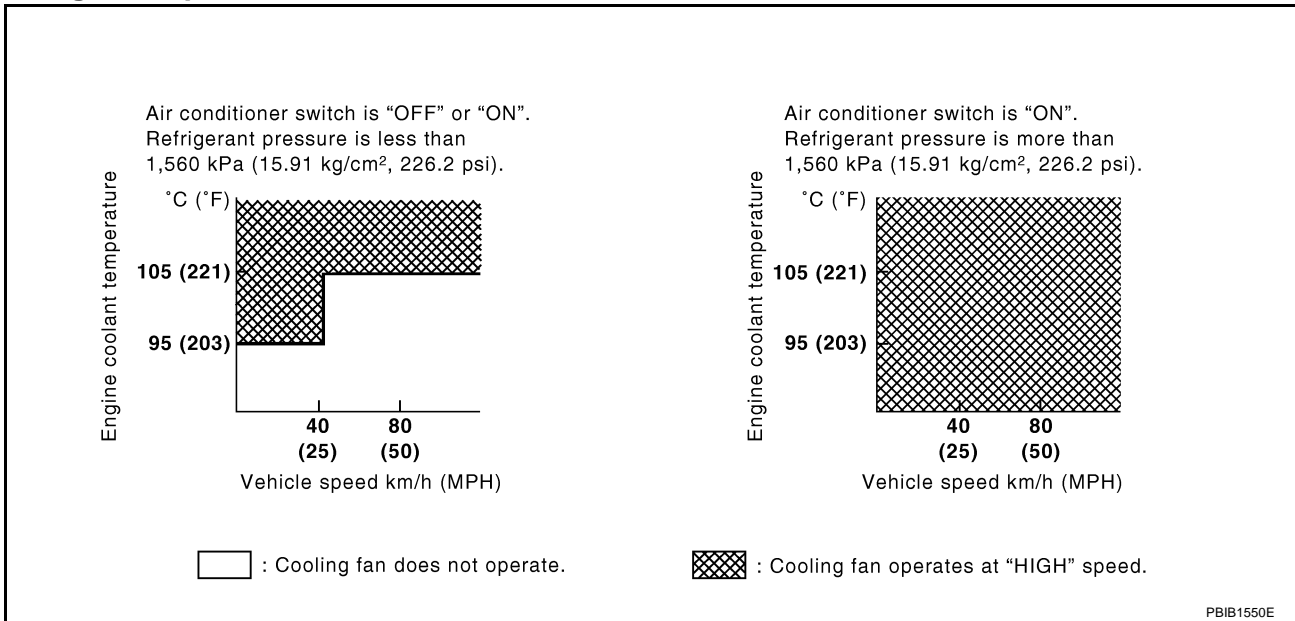

Cooling Fan Relay Operation

The ECM controls cooling fan relays in the IPDM E/R through CAN communication line.

Cooling fan speed	Cooling fan relay	
	1	3
Stop (OFF)	OFF	OFF
High (HI)	ON	ON

DTC P1217 ENGINE OVER TEMPERATURE

[VK45DE]

COMPONENT DESCRIPTION

The cooling fan at each speed when the current flows in the cooling fan motor as follows.

Cooling fan speed	Cooling fan motor terminals	
	(+)	(-)
High (HI)	1 and 2	3 and 4

CONSULT-II Reference Value in Data Monitor Mode

ABS00CAR

Specification data are reference values.

MONITOR ITEM	CONDITION	SPECIFICATION
COOLING FAN	<ul style="list-style-type: none"> Engine: After warming up, idle the engine 	Engine coolant temperature is 94°C (201°F) or less
	<ul style="list-style-type: none"> Air conditioner switch: OFF 	Engine coolant temperature is 95°C (203°F) or more

On Board Diagnosis Logic

ABS00CAS

If the cooling fan or another component in the cooling system malfunctions, engine coolant temperature will rise.

When the engine coolant temperature reaches an abnormally high temperature condition, a malfunction is indicated.

This self-diagnosis has the one trip detection logic.

DTC No.	Trouble diagnosis name	DTC detecting condition	Possible cause
P1217 1217	Engine over temperature (Overheat)	<ul style="list-style-type: none"> Cooling fan does not operate properly (Overheat). Cooling fan system does not operate properly (Overheat). Engine coolant was not added to the system using the proper filling method. Engine coolant is not within the specified range. 	<ul style="list-style-type: none"> Harness or connectors (The cooling fan circuit is open or shorted.) Cooling fan Radiator hose Radiator Radiator cap Water pump Thermostat <p>For more information, refer to EC-1150, "Main 12 Causes of Overheating".</p>

CAUTION:

When a malfunction is indicated, be sure to replace the coolant. Refer to [CO-36, "Changing Engine Coolant"](#). Also, replace the engine oil. Refer to [LU-26, "Changing Engine Oil"](#).

- Fill radiator with coolant up to specified level with a filling speed of 2 liters per minute. Be sure to use coolant with the proper mixture ratio. Refer to [MA-13, "Anti-Freeze Coolant Mixture Ratio"](#).
- After refilling coolant, run engine to ensure that no water-flow noise is emitted.

Overall Function Check

ABS00CAT

Use this procedure to check the overall function of the cooling fan. During this check, a DTC might not be confirmed.

WARNING:

Never remove the radiator cap when the engine is hot. Serious burns could be caused by high pressure fluid escaping from the radiator.

Wrap a thick cloth around cap. Carefully remove the cap by turning it a quarter turn to allow built-up pressure to escape. Then turn the cap all the way off.

DTC P1217 ENGINE OVER TEMPERATURE

[VK45DE]

WITH CONSULT-II

1. Check the coolant level in the reservoir tank and radiator.
Allow engine to cool before checking coolant level.
If the coolant level in the reservoir tank and/or radiator is below the proper range, skip the following steps and go to [EC-1147, "Diagnostic Procedure"](#).
2. Confirm whether customer filled the coolant or not. If customer filled the coolant, skip the following steps and go to [EC-1147, "Diagnostic Procedure"](#).
3. Turn ignition switch ON.
4. Perform "COOLING FAN" in "ACTIVE TEST" mode with CONSULT-II.
5. If the results are NG, go to [EC-1147, "Diagnostic Procedure"](#).

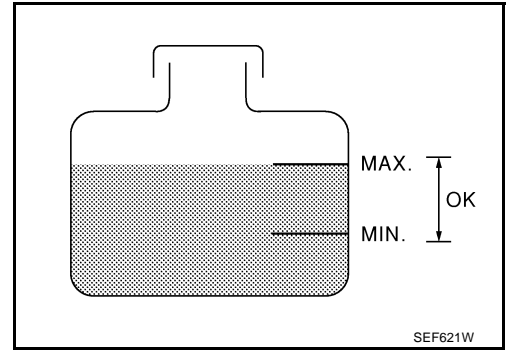

ACTIVE TEST	
COOLING FAN	OFF
MONITOR	
COOLAN TEMP/S	XXX °C

SEF646X

WITH GST

1. Check the coolant level in the reservoir tank and radiator.
Allow engine to cool before checking coolant level.
If the coolant level in the reservoir tank and/or radiator is below the proper range, skip the following steps and go to [EC-1147, "Diagnostic Procedure"](#).
2. Confirm whether customer filled the coolant or not. If customer filled the coolant, skip the following steps and go to [EC-1147, "Diagnostic Procedure"](#).
3. Disconnect engine coolant temperature sensor harness connector.
4. Connect 150Ω resistor to engine coolant temperature sensor harness connector.
5. Start engine and make sure that cooling fan operates at higher speed than low speed.
Be careful not to overheat engine.
6. If NG, go to [EC-1147, "Diagnostic Procedure"](#).

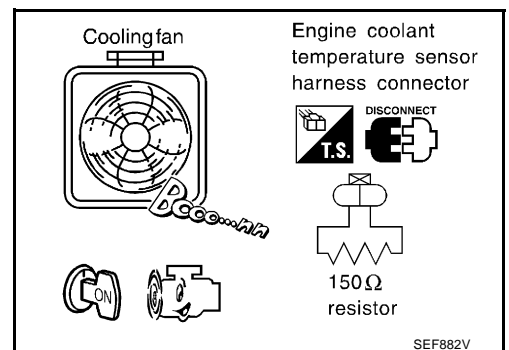
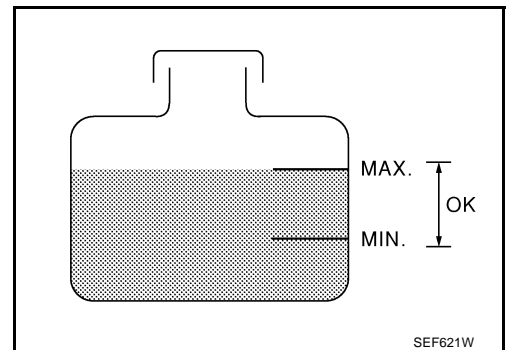

DTC P1217 ENGINE OVER TEMPERATURE

[VK45DE]

Wiring Diagram

ABS00CAU

EC-COOL/F-01

: DETECTABLE LINE FOR DTC
 : NON-DETECTABLE LINE FOR DTC
 : DATA LINE

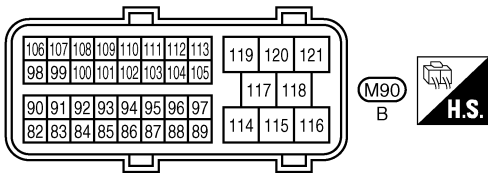
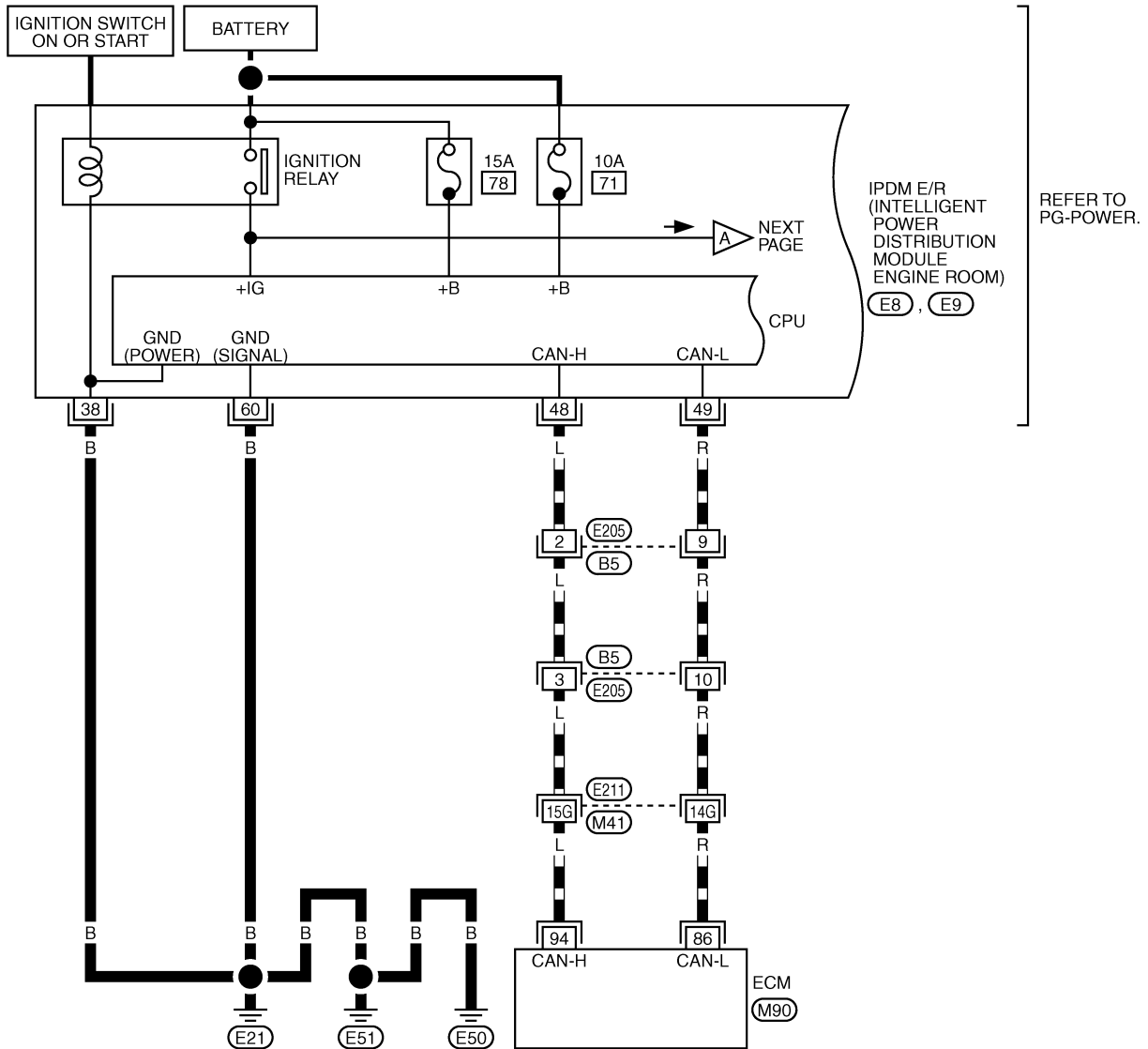

REFER TO THE FOLLOWING.
 (E21) -SUPER MULTIPLE JUNCTION (SMJ)

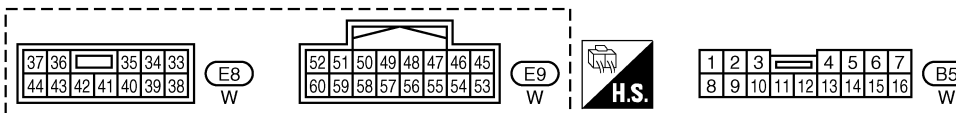

TBWM0254E

DTC P1217 ENGINE OVER TEMPERATURE

[VK45DE]

EC-COOL/F-02

: DETECTABLE LINE FOR DTC
 : NON-DETECTABLE LINE FOR DTC

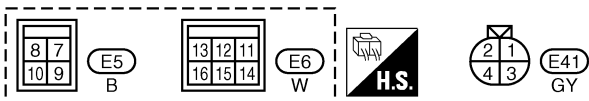
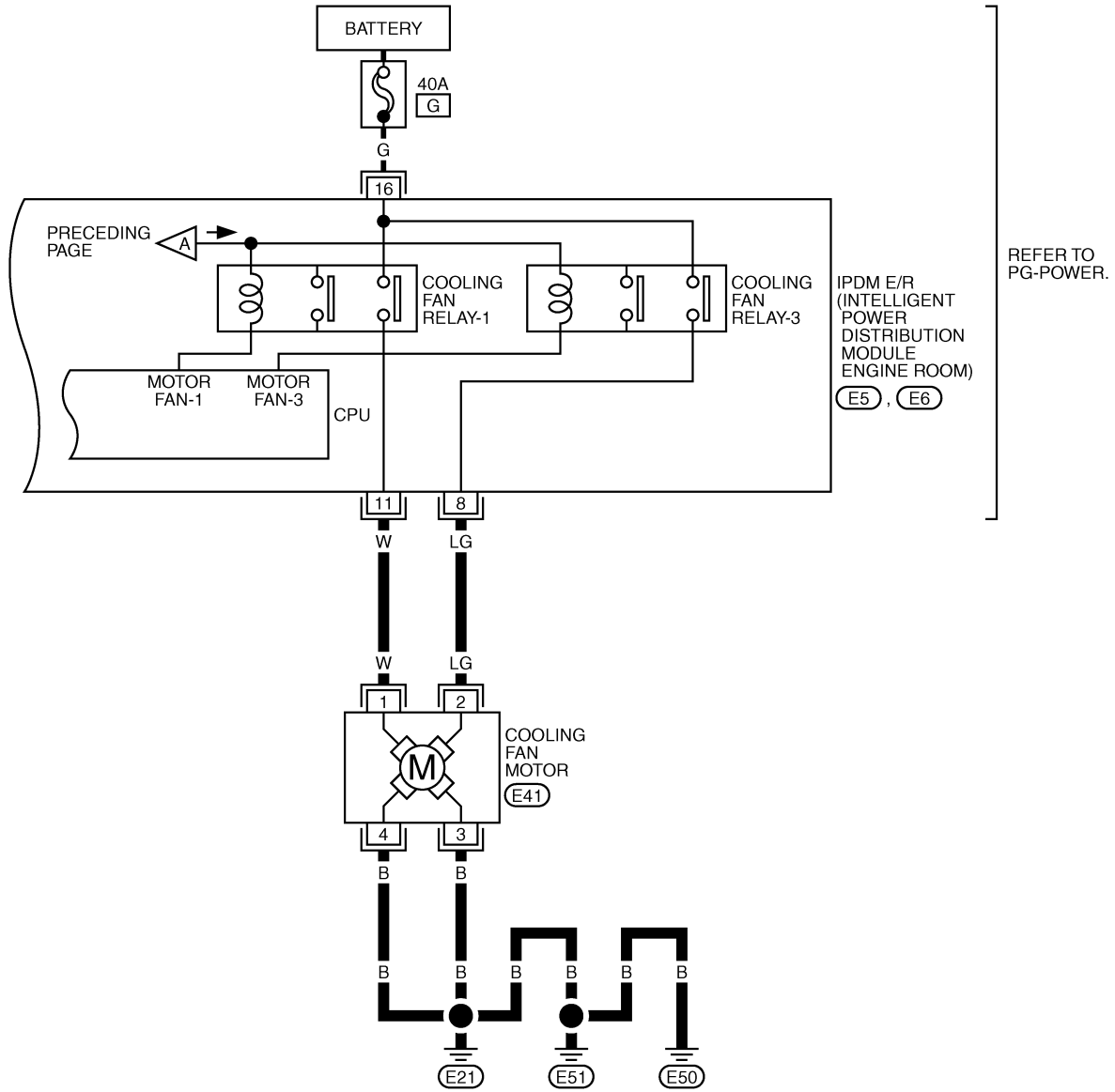

TBWM0255E

Diagnostic Procedure

1. INSPECTION START

Do you have CONSULT-II?

Yes or No

- Yes >> GO TO 2.
- No >> GO TO 3.

2. CHECK COOLING FAN MOTOR OPERATION

With CONSULT-II

1. Start engine and let it idle.
2. Select "COOLING FAN" in "ACTIVE TEST" mode with CONSULT-II.
3. Make sure that cooling fan operate.

OK or NG

- OK >> GO TO 4.
- NG >> Check cooling fan control circuit. (Go to [EC-1149](#), "PROCEDURE A".)

ACTIVE TEST	
COOLING FAN	OFF
MONITOR	
COOLANT TEMP/S	XXX °C

SEF646X

3. CHECK COOLING FAN MOTOR OPERATION

Without CONSULT-II

1. Disconnect engine coolant temperature sensor harness connector.
2. Connect 150Ω resistor to engine coolant temperature sensor harness connector.
3. Start engine and let it idle.
4. Make sure that cooling fan operate.

OK or NG

- OK >> GO TO 4.
- NG >> Check cooling fan control circuit. (Go to [EC-1149](#), "PROCEDURE A".)

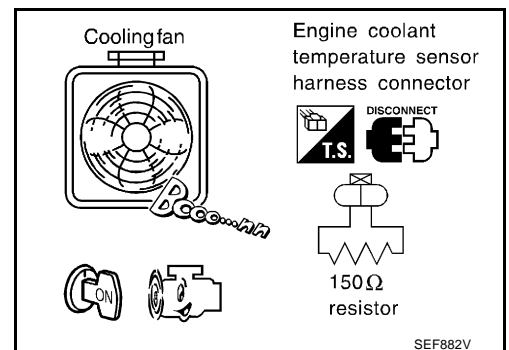

4. CHECK COOLING SYSTEM FOR LEAK

Apply pressure to the cooling system with a tester, and check if the pressure drops.

Testing pressure: 157 kPa (1.6 kg/cm² , 23 psi)

CAUTION:

Higher than the specified pressure may cause radiator damage. Pressure should not drop.

OK or NG

OK >> GO TO 5.

NG >> Check the following for leak. Refer to [CO-36, "LEAK CHECK"](#).

- Hose
- Radiator
- Water pump

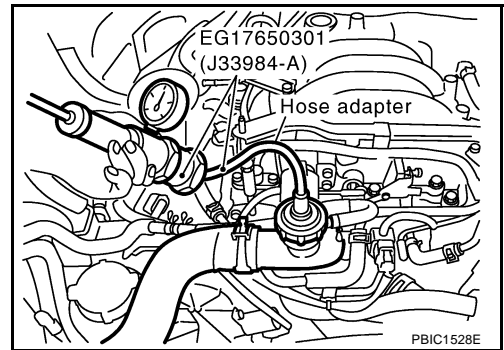

5. CHECK RADIATOR CAP

Apply pressure to cap with a tester.

Radiator cap relief pressure: 59 - 98 kPa (0.6 - 1.0 kg/cm² , 9 - 14 psi)

OK or NG

OK >> GO TO 6.

NG >> Replace radiator cap.

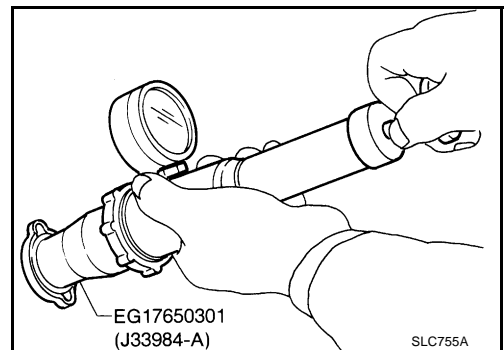

6. CHECK THERMOSTAT

1. Check valve seating condition at normal room temperatures. **It should seat tightly.**
2. Check valve opening temperature and valve lift.

Valve opening temperature: 82°C (180°F) [standard]

Valve lift: More than 10.0 mm/95°C (0.394 in/203°F)

3. Check if valve is closed at 5°C (9°F) below valve opening temperature. For details, refer to [CO-51, "THERMOSTAT AND WATER CONTROL VALVE"](#).

OK or NG

OK >> GO TO 7.

NG >> Replace thermostat

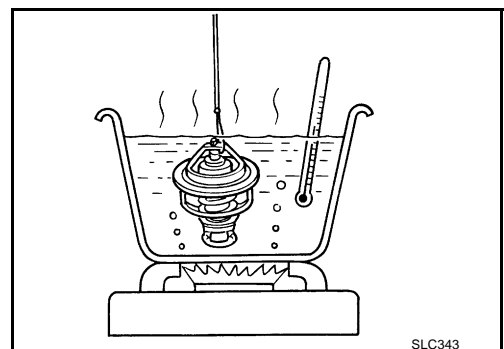

7. CHECK ENGINE COOLANT TEMPERATURE SENSOR

Refer to [EC-846, "Component Inspection"](#).

OK or NG

OK >> GO TO 8.

NG >> Replace engine coolant temperature sensor.

8. CHECK MAIN 12 CAUSES

If the cause cannot be isolated, go to [EC-1150, "Main 12 Causes of Overheating"](#) .

>> INSPECTION END

PROCEDURE A**1. CHECK POWER SUPPLY CIRCUIT**

1. Turn ignition switch OFF.
2. Disconnect IPDM E/R harness connector E6.
3. Check voltage between IPDM E/R terminal 16 and ground with CONSULT-II or tester.

Voltage: Battery voltage

OK or NG

- OK >> GO TO 3.
 NG >> GO TO 2.

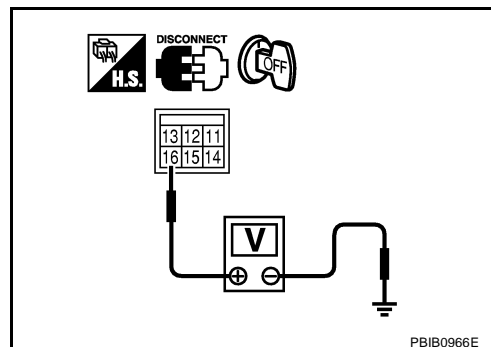
**2. DETECT MALFUNCTIONING PART**

Check the following.

- 40A fusible link
- Harness for open or short between IPDM E/R and battery

>> Repair open circuit or short to ground or short to power in harness or connectors.

3. CHECK COOLING FAN MOTOR CIRCUIT FOR OPEN OR SHORT

1. Disconnect IPDM E/R harness connector E5.
2. Disconnect cooling fan motor harness connector.
3. Check harness continuity between cooling fan motor terminal 1 and IPDM E/R terminal 11, cooling fan motor terminal 2 and IPDM E/R terminal 8. Refer to wiring diagram.

Continuity should exist.

4. Also check harness for short to ground and short to power.

OK or NG

- OK >> GO TO 4.
 NG >> Repair open circuit or short to ground or short to power in harness or connectors.

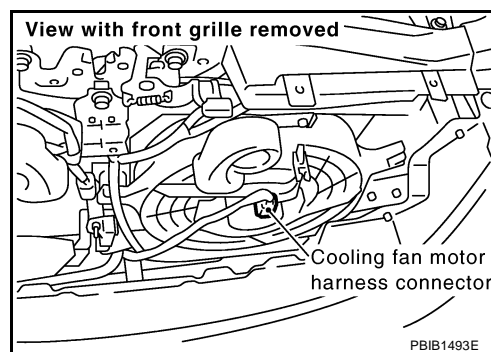

4. CHECK COOLING FAN MOTOR GROUND CIRCUIT FOR OPEN OR SHORT

1. Check harness continuity between the following;
cooling fan motor terminal 3 and ground,
cooling fan motor terminal 4 and ground.
Refer to wiring diagram.

Continuity should exist.

2. Also check harness for short to power.

OK or NG

OK >> GO TO 5.

NG >> Repair open circuit or short to power in harness or connectors.

5. CHECK COOLING FAN MOTOR

Refer to [EC-1151, "Component Inspection"](#) .

OK or NG

OK >> GO TO 6.

NG >> Replace cooling fan motor.

6. CHECK INTERMITTENT INCIDENT

Perform [EC-784, "TROUBLE DIAGNOSIS FOR INTERMITTENT INCIDENT"](#) .

OK or NG

OK >> Replace IPDM E/R. Refer to [PG-18, "IPDM E/R \(INTELLIGENT POWER DISTRIBUTION MODULE ENGINE ROOM\)"](#) .

NG >> Repair or replace harness connectors.

Main 12 Causes of Overheating

ABS00CAW

Engine	Step	Inspection item	Equipment	Standard	Reference page
OFF	1	<ul style="list-style-type: none"> ● Blocked radiator ● Blocked condenser ● Blocked radiator grille ● Blocked bumper 	● Visual	No blocking	—
	2	● Coolant mixture	● Coolant tester	50 - 50% coolant mixture	MA-13
	3	● Coolant level	● Visual	Coolant up to MAX level in reservoir tank and radiator filler neck	CO-36
	4	● Radiator cap	● Pressure tester	59 - 98 kPa (0.6 - 1.0 kg/cm ² , 9 - 14 psi) (Limit)	CO-41
ON*2	5	● Coolant leaks	● Visual	No leaks	CO-36
ON*2	6	● Thermostat	● Touch the upper and lower radiator hoses	Both hoses should be hot	CO-51
ON*1	7	● Cooling fan	● CONSULT-II	Operating	See trouble diagnosis for DTC P1217 (EC-1142).
OFF	8	● Combustion gas leak	● Color checker chemical tester 4 Gas analyzer	Negative	—
ON*3	9	● Coolant temperature gauge	● Visual	Gauge less than 3/4 when driving	—
		● Coolant overflow to reservoir tank	● Visual	No overflow during driving and idling	CO-36
OFF*4	10	● Coolant return from reservoir tank to radiator	● Visual	Should be initial level in reservoir tank	CO-36

DTC P1217 ENGINE OVER TEMPERATURE

[VK45DE]

Engine	Step	Inspection item	Equipment	Standard	Reference page
OFF	11	● Cylinder head	● Straight gauge feeler gauge	0.1 mm (0.004 in) Maximum distortion (warping)	EM-224
	12	● Cylinder block and pistons	● Visual	No scuffing on cylinder walls or piston	EM-240

*1: Turn the ignition switch ON.

*2: Engine running at 3,000 rpm for 10 minutes.

*3: Drive at 90 km/h (55 MPH) for 30 minutes and then let idle for 10 minutes.

*4: After 60 minutes of cool down time.

For more information, refer to [CO-32. "OVERHEATING CAUSE ANALYSIS"](#) .

Component Inspection

ABS00CAX

COOLING FAN MOTOR

1. Disconnect cooling fan motor harness connector.
2. Supply cooling fan motor terminals with battery voltage and check operation.

	Speed	Terminals	
		(+)	(-)
Cooling fan motor	High	1, 2	3, 4

Cooling fan motor should operate.

If NG, replace cooling fan motor.

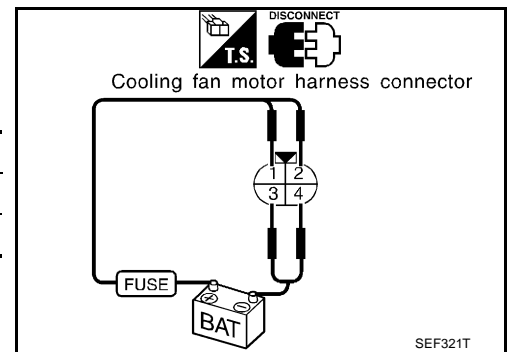

DTC P1225 TP SENSOR

PFP:16119

Component Description

ABS00CAY

Electric throttle control actuator consists of throttle control motor, throttle position sensor, etc. The throttle position sensor responds to the throttle valve movement.

The throttle position sensor has the two sensors. These sensors are a kind of potentiometers which transform the throttle valve position into output voltage, and emit the voltage signal to the ECM. In addition, these sensors detect the opening and closing speed of the throttle valve and feed the voltage signals to the ECM. The ECM judges the current opening angle of the throttle valve from these signals and the ECM controls the throttle control motor to make the throttle valve opening angle properly in response to driving condition.

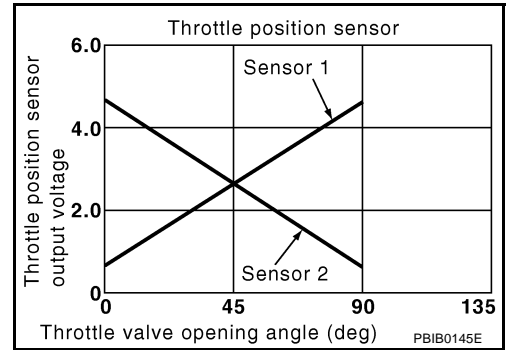

On Board Diagnosis Logic

ABS00CAZ

The MIL will not light up for this diagnosis.

DTC No.	Trouble diagnosis name	DTC detecting condition	Possible cause
P1225 1225	Closed throttle position learning performance problem	Closed throttle position learning value is excessively low.	<ul style="list-style-type: none"> ● Electric throttle control actuator (TP sensor 1 and 2)

DTC Confirmation Procedure

ABS00CB0

NOTE:

If DTC Confirmation Procedure has been previously conducted, always turn ignition switch OFF and wait at least 10 seconds before conducting the next test.

TESTING CONDITION:

Before performing the following procedure, confirm that battery voltage is more than 10V at idle.

WITH CONSULT-II

1. Turn ignition switch ON.
2. Select "DATA MONITOR" mode with CONSULT-II.
3. Turn ignition switch OFF, wait at least 10 seconds.
4. Turn ignition switch ON.
5. If 1st trip DTC is detected, go to [EC-1153, "Diagnostic Procedure"](#).

DATA MONITOR	
MONITOR	NO DTC
ENG SPEED	XXX rpm

SEF058Y

WITH GST

Follow the procedure "WITH CONSULT-II" above.

Diagnostic Procedure**1. CHECK ELECTRIC THROTTLE CONTROL ACTUATOR VISUALLY**

1. Turn ignition switch OFF.
2. Remove the intake air duct.
3. Check if foreign matter is caught between the throttle valve and the housing.

OK or NG

- OK >> GO TO 2.
 NG >> Remove the foreign matter and clean the electric throttle control actuator inside.

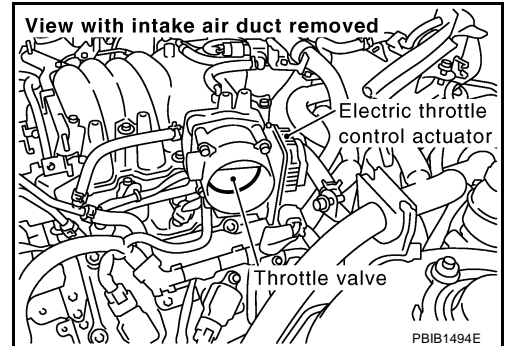
**2. REPLACE ELECTRIC THROTTLE CONTROL ACTUATOR**

1. Replace the electric throttle control actuator.
2. Perform [EC-698, "Throttle Valve Closed Position Learning"](#) .
3. Perform [EC-698, "Idle Air Volume Learning"](#) .

>> INSPECTION END

Removal and Installation
ELECTRIC THROTTLE CONTROL ACTUATOR

Refer to [EM-174, "INTAKE MANIFOLD"](#) .

DTC P1226 TP SENSOR

PFP:16119

Component Description

ABS00CB3

Electric throttle control actuator consists of throttle control motor, throttle position sensor, etc. The throttle position sensor responds to the throttle valve movement.

The throttle position sensor has the two sensors. These sensors are a kind of potentiometers which transform the throttle valve position into output voltage, and emit the voltage signal to the ECM. In addition, these sensors detect the opening and closing speed of the throttle valve and feed the voltage signals to the ECM. The ECM judges the current opening angle of the throttle valve from these signals and the ECM controls the throttle control motor to make the throttle valve opening angle properly in response to driving condition.

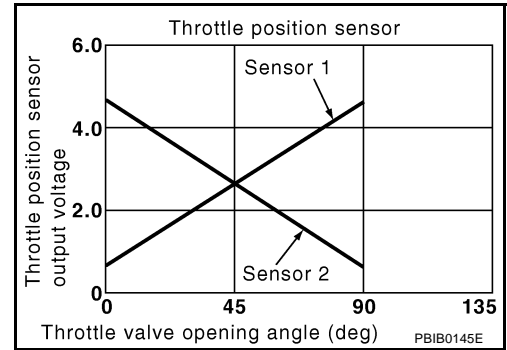

On Board Diagnosis Logic

ABS00CB4

The MIL will not light up for this diagnosis.

DTC No.	Trouble diagnosis name	DTC detecting condition	Possible cause
P1226 1226	Closed throttle position learning performance problem	Closed throttle position learning is not performed successfully, repeatedly.	<ul style="list-style-type: none"> Electric throttle control actuator (TP sensor 1 and 2)

DTC Confirmation Procedure

ABS00CB5

NOTE:

If DTC Confirmation Procedure has been previously conducted, always turn ignition switch OFF and wait at least 10 seconds before conducting the next test.

TESTING CONDITION:

Before performing the following procedure, confirm that battery voltage is more than 10V at idle.

WITH CONSULT-II

1. Turn ignition switch ON.
2. Select "DATA MONITOR" mode with CONSULT-II.
3. Turn ignition switch OFF, wait at least 10 seconds.
4. Turn ignition switch ON.
5. Repeat steps 3 and 4 for 32 times.
6. If 1st trip DTC is detected, go to [EC-1155, "Diagnostic Procedure"](#).

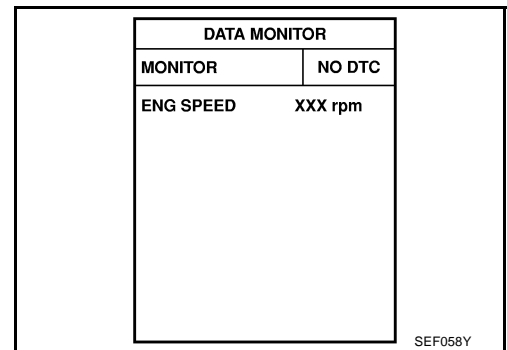

WITH GST

Follow the procedure "WITH CONSULT-II" above.

Diagnostic Procedure**1. CHECK ELECTRIC THROTTLE CONTROL ACTUATOR VISUALLY**

1. Turn ignition switch OFF.
2. Remove the intake air duct.
3. Check if foreign matter is caught between the throttle valve and the housing.

OK or NG

- OK >> GO TO 2.
 NG >> Remove the foreign matter and clean the electric throttle control actuator inside.

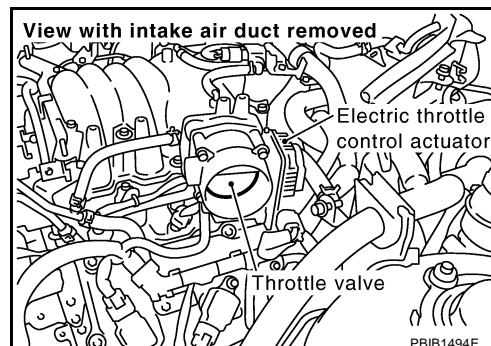
**2. REPLACE ELECTRIC THROTTLE CONTROL ACTUATOR**

1. Replace the electric throttle control actuator.
2. Perform [EC-698, "Throttle Valve Closed Position Learning"](#) .
3. Perform [EC-698, "Idle Air Volume Learning"](#) .

>> INSPECTION END

Removal and Installation
ELECTRIC THROTTLE CONTROL ACTUATOR

Refer to [EM-174, "INTAKE MANIFOLD"](#) .

DTC P1229 SENSOR POWER SUPPLY

[VK45DE]

DTC P1229 SENSOR POWER SUPPLY

PFP:16119

On Board Diagnosis Logic

ABS00CB8

This self-diagnosis has the one trip detection logic.

DTC No.	Trouble diagnosis name	DTC detecting condition	Possible cause
P1229 1229	Sensor power supply circuit short	ECM detects a voltage of power source for sensor is excessively low or high.	<ul style="list-style-type: none">● Harness or connectors (APP sensor 1 circuit is shorted.) (Mass air flow sensor is shorted.) (EVAP control system pressure sensor is shorted.) (Refrigerant pressure sensor circuit is shorted.) (PSP sensor circuit is shorted.)● Accelerator pedal position sensor● Mass air flow sensor● EVAP control system pressure sensor● Refrigerant pressure sensor● Power steering pressure sensor

FAIL-SAFE MODE

When the malfunction is detected, ECM enters fail-safe mode and the MIL lights up.

Engine operation condition in fail-safe mode

ECM stops the electric throttle control actuator control, throttle valve is maintained at a fixed opening (approx. 5 degrees) by the return spring.

DTC Confirmation Procedure

ABS00CB9

NOTE:

If DTC Confirmation Procedure has been previously conducted, always turn ignition switch OFF and wait at least 10 seconds before conducting the next test.

TESTING CONDITION:

Before performing the following procedure, confirm that battery voltage is more than 10V at idle.

④ WITH CONSULT-II

1. Turn ignition switch ON.
2. Select "DATA MONITOR" mode with CONSULT-II.
3. Start engine and let it idle for 1 second.
4. If DTC is detected, go to [EC-1158, "Diagnostic Procedure"](#).

DATA MONITOR	
MONITOR	NO DTC
ENG SPEED	XXX rpm

SEF058Y

④ WITH GST

Follow the procedure "WITH CONSULT-II" above.

DTC P1229 SENSOR POWER SUPPLY

[VK45DE]

ABS00CBA

Wiring Diagram

EC-SEN/PW-01

: DETECTABLE LINE FOR DTC
 : NON-DETECTABLE LINE FOR DTC

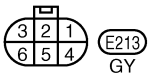
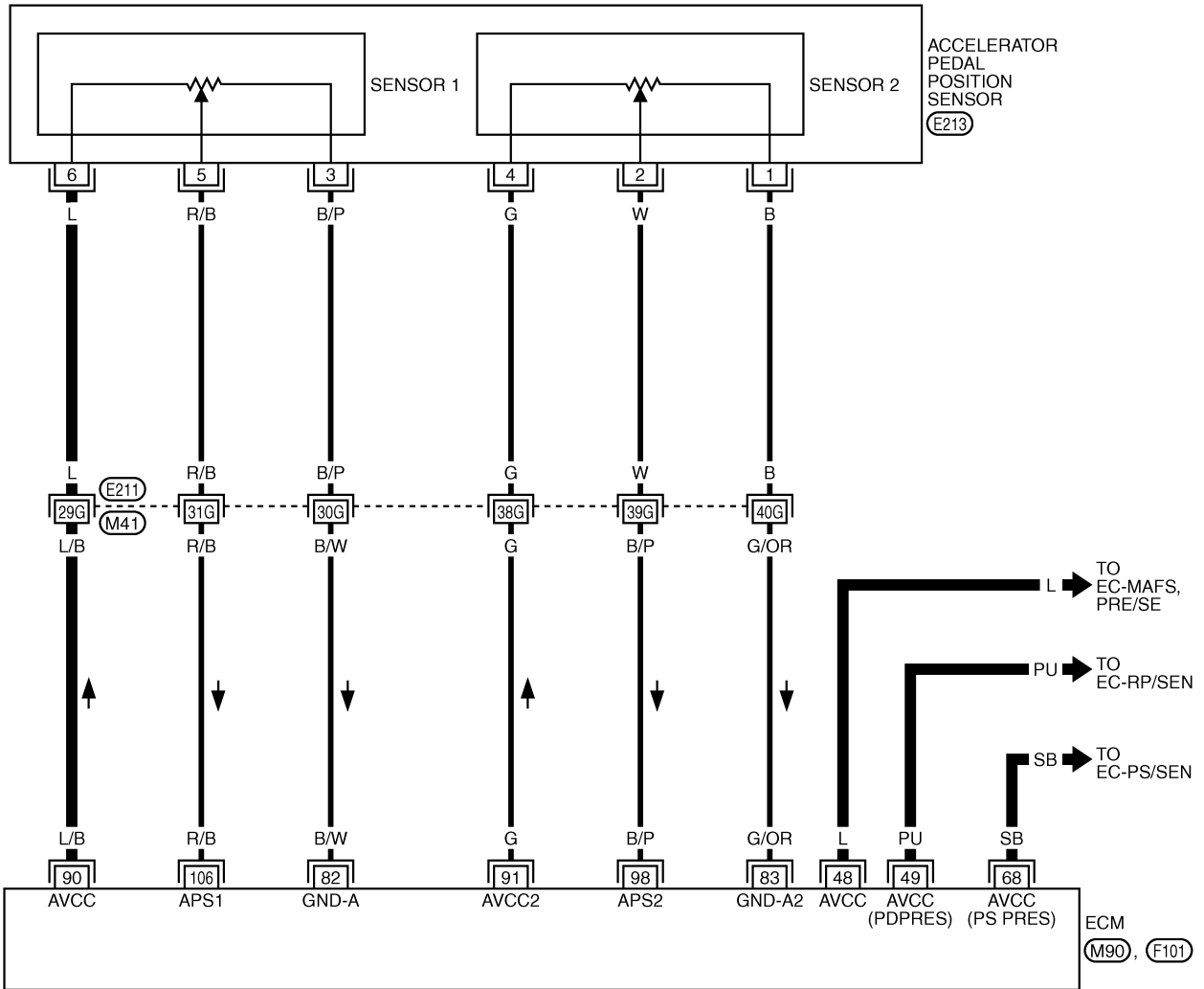

REFER TO THE FOLLOWING.
 E211 -SUPER MULTIPLE JUNCTION (SMJ)

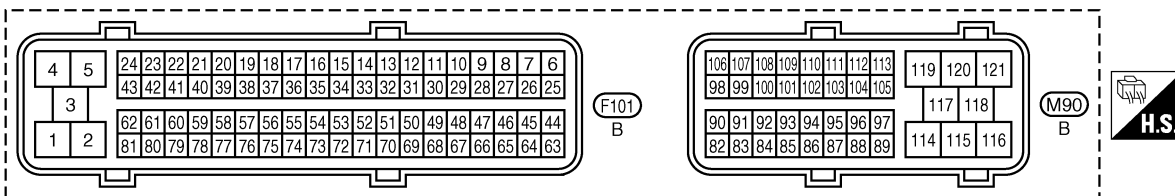

TBWM0420E

DTC P1229 SENSOR POWER SUPPLY

[VK45DE]

Specification data are reference values and are measured between each terminal and ground.

CAUTION:

Do not use ECM ground terminals when measuring input/output voltage. Doing so may result in damage to the ECM's transistor. Use a ground other than ECM terminals, such as the ground.

TERMINAL NO.	WIRE COLOR	ITEM	CONDITION	DATA (DC Voltage)
48	L	Sensor power supply (Mass air flow sensor / EVAP control system pressure sensor)	[Ignition switch: ON]	Approximately 5V
49	PU	Sensor power supply (Refrigerant pressure sensor)	[Ignition switch: ON]	Approximately 5V
68	SB	Sensor power supply (Power steering pressure sensor)	[Ignition switch: ON]	Approximately 5V
90	L/B	Sensor power supply (APP sensor 1)	[Ignition switch: ON]	Approximately 5V

Diagnostic Procedure

ABS00CBB

1. CHECK GROUND CONNECTIONS

1. Turn ignition switch OFF.
2. Loosen and retighten three ground screws on the body.
Refer to [EC-791, "Ground Inspection"](#).

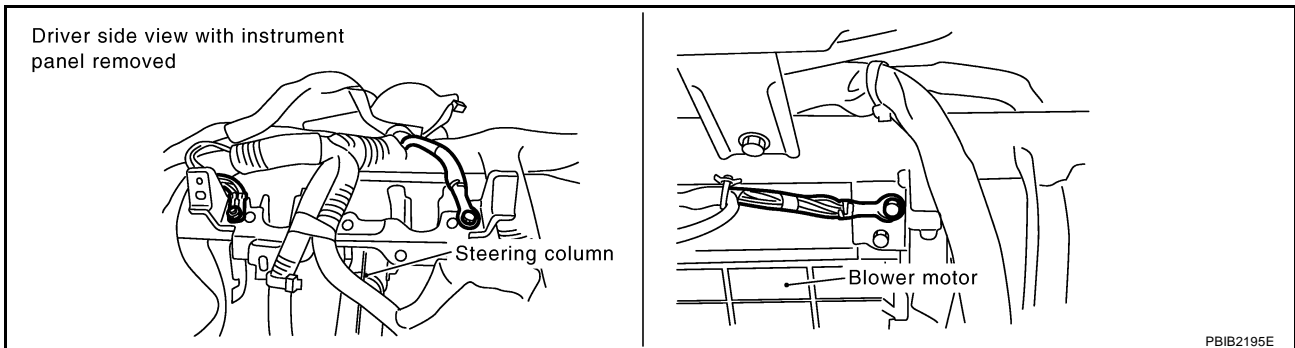

OK or NG

- OK >> GO TO 2.
- NG >> Repair or replace ground connections.

2. CHECK ACCELERATOR PEDAL POSITION SENSOR 1 POWER SUPPLY CIRCUIT

1. Disconnect accelerator pedal position (APP) sensor harness connector.
2. Turn ignition switch ON.
3. Check voltage between APP sensor terminal 6 and ground with CONSULT-II or tester.

Voltage: Approximately 5V

OK or NG

- OK >> GO TO 5.
- NG >> GO TO 3.

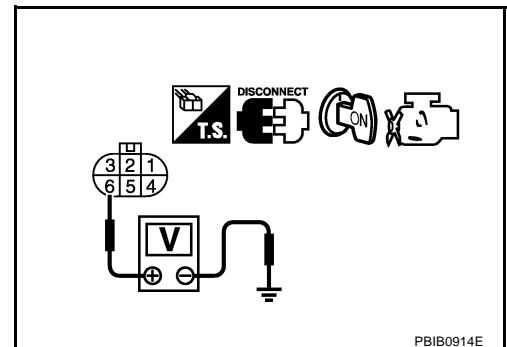

3. CHECK SENRO POWER SUPPLY CIRCUITS

Check harness for short to power and short to ground, between the following terminals.

ECM terminal	Sensor terminal	Reference Wiring Diagram
90	APP sensor terminal 6	EC-1227
48	Mass air flow sensor terminal 2	EC-825
48	EVAP control pressure sensor terminal 3	EC-1009
49	Refrigerant pressure sensor terminal 1	EC-1288
68	PSP sensor terminal 1	EC-1053

OK or NG

OK >> GO TO 4.

NG >> Repair short to ground or short to power in harness or connectors.

4. CHECK COMPONENTS

Check the following.

- Mass air flow sensor (Refer to [EC-829, "Component Inspection"](#) .)
- EVAP control pressure sensor (Refer to [EC-1013, "Component Inspection"](#) .)
- Refrigerant pressure sensor (Refer to [ATC-90, "COMPONENT INSPECTION"](#) .)
- Power steering pressure sensor (Refer to [EC-1056, "Component Inspection"](#) .)

OK or NG

OK >> GO TO 7.

NG >> Replace malfunctioning component.

5. CHECK APP SENSOR

Refer to [EC-1230, "Component Inspection"](#) .

OK or NG

OK >> GO TO 7.

NG >> GO TO 6.

6. REPLACE ACCELERATOR PEDAL ASSEMBLY

1. Replace accelerator pedal assembly.
2. Perform [EC-698, "Accelerator Pedal Released Position Learning"](#) .
3. Perform [EC-698, "Throttle Valve Closed Position Learning"](#) .
4. Perform [EC-698, "Idle Air Volume Learning"](#) .

>> INSPECTION END

7. CHECK INTERMITTENT INCIDENT

Refer to [EC-784, "TROUBLE DIAGNOSIS FOR INTERMITTENT INCIDENT"](#) .

>> INSPECTION END

DTC P1444 EVAP CANISTER PURGE VOLUME CONTROL SOLENOID VALVE [VK45DE]

DTC P1444 EVAP CANISTER PURGE VOLUME CONTROL SOLENOID VALVE

PFP:14920

Description SYSTEM DESCRIPTION

ABS00CBC

Sensor	Input signal to ECM	ECM function	Actuator
Crankshaft position sensor (POS) Camshaft position sensor (PHASE)	Engine speed *1	EVAP canister purge flow control	EVAP canister purge vol- ume control solenoid valve
Mass air flow sensor	Amount of intake air		
Engine coolant temperature sensor	Engine coolant temperature		
Battery	Battery voltage*1		
Throttle position sensor	Throttle position		
Accelerator pedal position sensor	Accelerator pedal position		
Heated oxygen sensor 1	Density of oxygen in exhaust gas (Mixture ratio feedback signal)		
Fuel tank temperature sensor	Fuel temperature in fuel tank		
Wheel sensor*2	Vehicle speed		

*1:ECM determines the start signal status by the signals of engine speed and battery voltage.

*2: This signal is sent to the ECM through CAN communication line.

This system controls flow rate of fuel vapor from the EVAP canister. The opening of the vapor by-pass passage in the EVAP canister purge volume control solenoid valve changes to control the flow rate. The EVAP canister purge volume control solenoid valve repeats ON/OFF operation according to the signal sent from the ECM. The opening of the valve varies for optimum engine control. The optimum value stored in the ECM is determined by considering various engine conditions. When the engine is operating, the flow rate of fuel vapor from the EVAP canister is regulated as the air flow changes.

COMPONENT DESCRIPTION

The EVAP canister purge volume control solenoid valve uses a ON/OFF duty to control the flow rate of fuel vapor from the EVAP canister. The EVAP canister purge volume control solenoid valve is moved by ON/OFF pulses from the ECM. The longer the ON pulse, the greater the amount of fuel vapor that will flow through the valve.

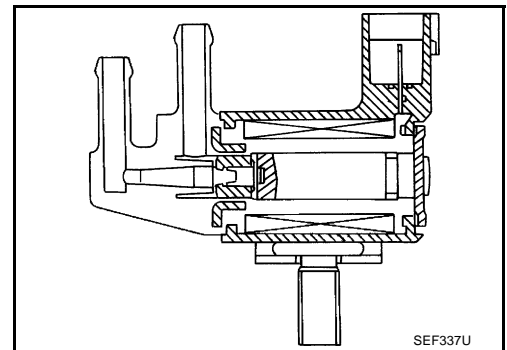

CONSULT-II Reference Value in Data Monitor Mode

ABS00CBD

Specification data are reference values.

MONITOR ITEM	CONDITION		SPECIFICATION
PURG VOL C/V	<ul style="list-style-type: none"> ● Engine: After warming up ● Air conditioner switch: OFF ● Shift lever: N ● No load 	Idle	0%
		2,000 rpm	—

DTC P1444 EVAP CANISTER PURGE VOLUME CONTROL SOLENOID VALVE [VK45DE]

ABS00CBE

On Board Diagnosis Logic

DTC No.	Trouble diagnosis name	DTC detecting condition	Possible cause
P1444 1444	EVAP canister purge volume control solenoid valve	The canister purge flow is detected during the specified driving conditions, even when EVAP canister purge volume control solenoid valve is completely closed.	<ul style="list-style-type: none"> ● EVAP control system pressure sensor ● EVAP canister purge volume control solenoid valve (The valve is stuck open.) ● EVAP canister vent control valve ● EVAP canister ● Hoses (Hoses are connected incorrectly or clogged.)

DTC Confirmation Procedure

ABS00CBF

NOTE:

If DTC Confirmation Procedure has been previously conducted, always turn ignition switch OFF and wait at least 10 seconds before conducting the next test.

TESTING CONDITION:

Always perform test at a temperature of 5°C (41°F) or more.

Ⓜ WITH CONSULT-II

1. Start engine and warm it up to normal operating temperature.
2. Turn ignition switch OFF and wait at least 10 seconds.
3. Turn ignition switch ON.
4. Select "PURG VOL CN/V P1444" of "EVAPORATIVE SYSTEM" in "DTC WORK SUPPORT" mode with CONSULT-II.
5. Touch "START".

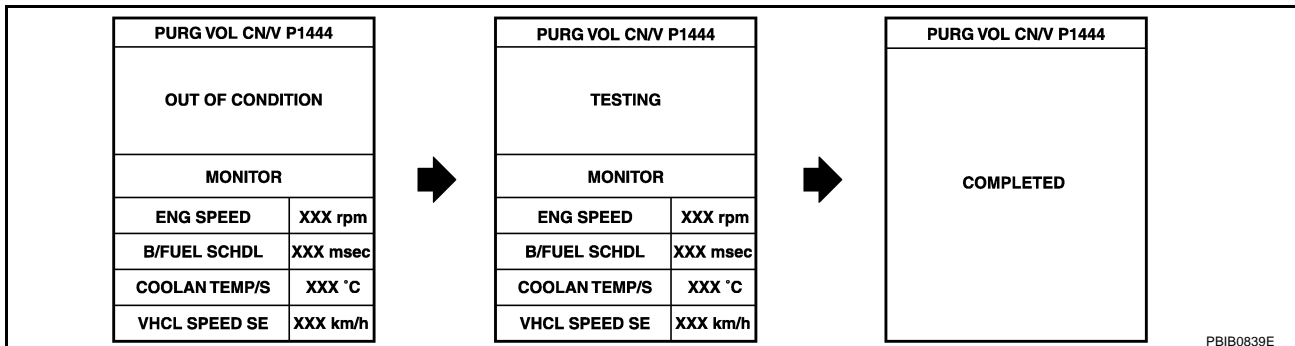

6. Start engine and let it idle until "TESTING" on CONSULT-II changes to "COMPLETED". (It will take approximately 10 seconds.)
If "TESTING" is not displayed after 5 minutes, retry from step 2.
7. Make sure that "OK" is displayed after touching "SELF-DIAG RESULTS". If "NG" is displayed, refer to [EC-1164, "Diagnostic Procedure"](#).

Ⓜ WITH GST

1. Start engine and warm it up to normal operating temperature.
2. Turn ignition switch OFF and wait at least 10 seconds.
3. Start engine and let it idle for at least 20 seconds.
4. Select MODE 7 with GST.
5. If 1st trip DTC is detected, go to [EC-1164, "Diagnostic Procedure"](#).

DTC P1444 EVAP CANISTER PURGE VOLUME CONTROL SOLENOID VALVE [VK45DE]

ABS00CBG

Wiring Diagram

EC-PGC/V-01

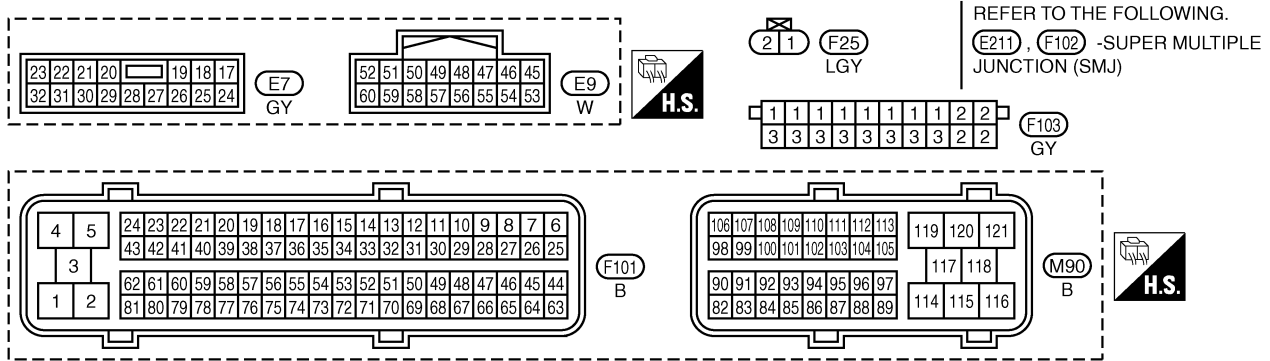
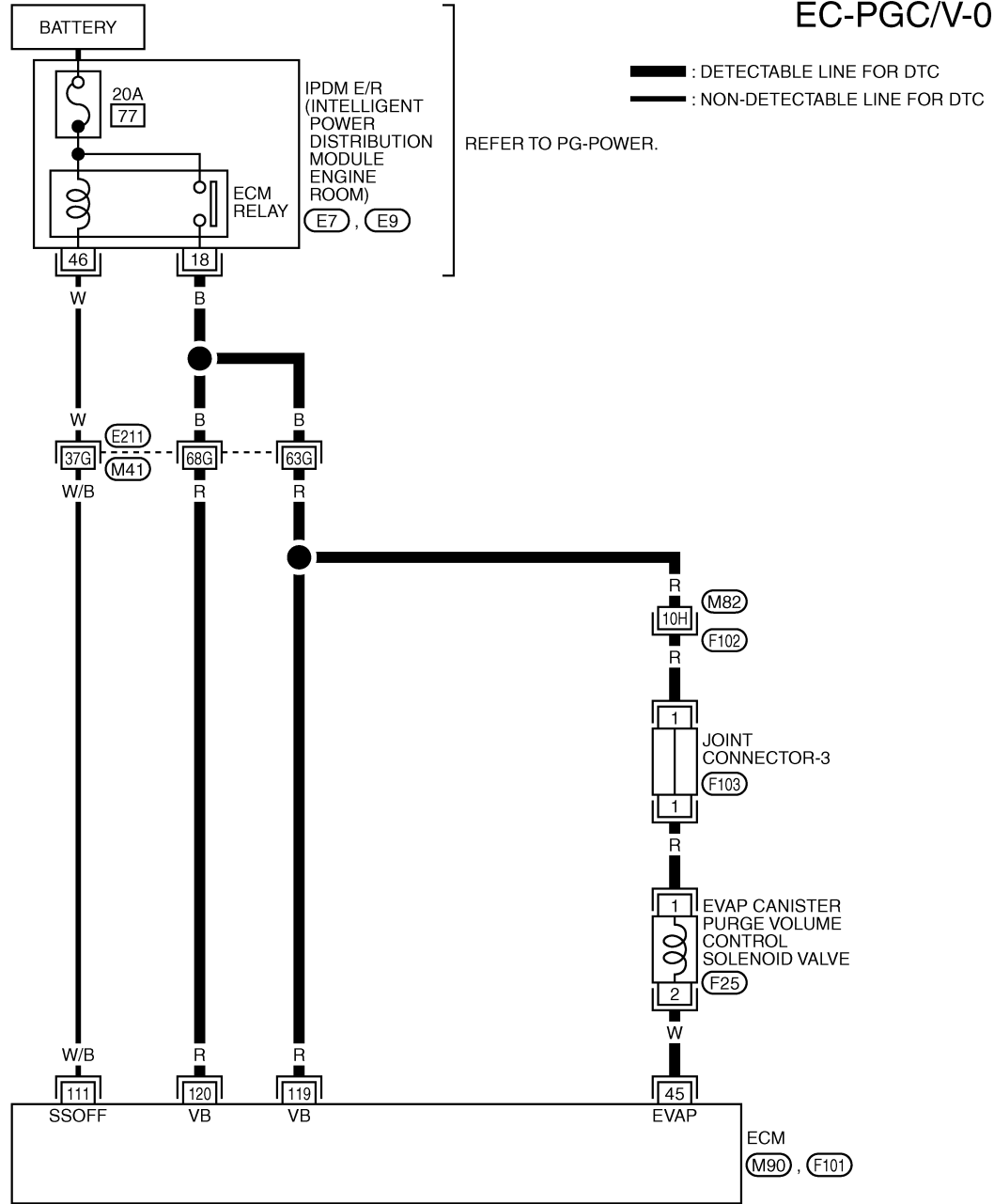

TBWM0246E

DTC P1444 EVAP CANISTER PURGE VOLUME CONTROL SOLENOID VALVE [VK45DE]

Specification data are reference values and are measured between each terminal and ground.
Pulse signal is measured by CONSULT-II.

CAUTION:

Do not use ECM ground terminals when measuring input/output voltage. Doing so may result in damage to the ECM's transistor. Use a ground other than ECM terminals, such as the ground.

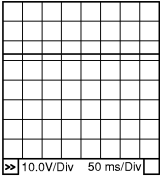
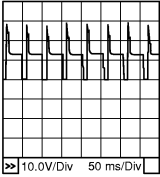
TER-MINAL NO.	WIRE COLOR	ITEM	CONDITION	DATA (DC Voltage)
45	W	EVAP canister purge volume control solenoid valve	[Engine is running] <ul style="list-style-type: none"> ● Idle speed 	BATTERY VOLTAGE (11 - 14V) [★]  <small>10.0V/Div 50 ms/Div</small> PBIB0050E
			[Engine is running] <ul style="list-style-type: none"> ● Engine speed is about 2,000 rpm (More than 100 seconds after starting engine) 	11 - 14V [★]  <small>10.0V/Div 50 ms/Div</small> PBIB0051E
111	W/B	ECM relay (Self shut-off)	[Engine is running] [Ignition switch: OFF] <ul style="list-style-type: none"> ● For a few seconds after turning ignition switch OFF 	0 - 1.5V
			[Ignition switch: OFF] <ul style="list-style-type: none"> ● More than a few seconds after turning ignition switch OFF 	BATTERY VOLTAGE (11 - 14V)
119 120	R R	Power supply for ECM	[Ignition switch: ON]	BATTERY VOLTAGE (11 - 14V)

★: Average voltage for pulse signal (Actual pulse signal can be confirmed by oscilloscope.)

A
EC
C
D
E
F
G
H
I
J
K
L
M

DTC P1444 EVAP CANISTER PURGE VOLUME CONTROL SOLENOID VALVE [VK45DE]

ABS00CBH

Diagnostic Procedure

1. CHECK EVAP CANISTER PURGE VOLUME CONTROL SOLENOID VALVE POWER SUPPLY CIRCUIT

1. Turn ignition switch OFF.
2. Disconnect EVAP canister purge volume control solenoid valve harness connector.
3. Turn ignition switch ON.

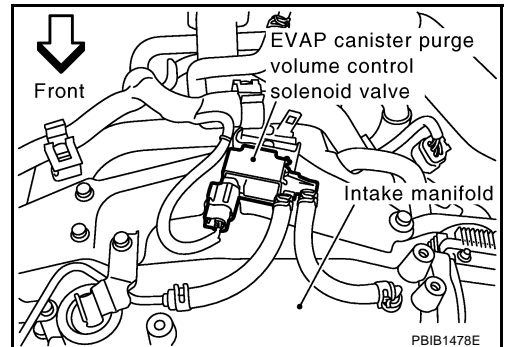

4. Check voltage between EVAP canister purge volume control solenoid valve terminal 1 and ground with CONSULT-II or tester.

Voltage: Battery voltage

OK or NG

- OK >> GO TO 3.
- NG >> GO TO 2.

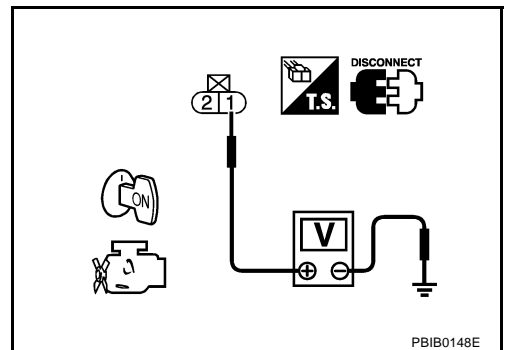

2. DETECT MALFUNCTIONING PART

Check the following.

- Harness connectors E211, M41
- Harness connectors M82, F102
- Joint connector-3
- IPDM E/R harness connector E7
- Harness for open or short between EVAP canister purge volume control solenoid valve and IPDM E/R
- Harness for open or short between EVAP canister purge volume control solenoid valve and ECM

>> Repair open circuit or short to ground or short to power in harness or connectors.

3. CHECK EVAP CANISTER PURGE VOLUME CONTROL SOLENOID VALVE OUTPUT SIGNAL CIRCUIT FOR OPEN AND SHORT

1. Turn ignition switch OFF.
2. Disconnect ECM harness connector.
3. Check harness continuity between ECM terminal 45 and EVAP canister purge volume control solenoid valve terminal 2. Refer to Wiring Diagram.

Continuity should exist.

4. Also check harness for short to ground and short to power.

OK or NG

- OK >> GO TO 4.
- NG >> Repair open circuit or short to ground or short to power in harness or connectors.

DTC P1444 EVAP CANISTER PURGE VOLUME CONTROL SOLENOID VALVE [VK45DE]

4. CHECK EVAP CONTROL SYSTEM PRESSURE SENSOR CONNECTOR

1. Disconnect EVAP control system pressure sensor harness connector.
2. Check connectors for water.

Water should not exist.

OK or NG

- OK >> GO TO 5.
NG >> Replace EVAP control system pressure sensor.

5. CHECK EVAP CONTROL SYSTEM PRESSURE SENSOR

Refer to [EC-1013, "Component Inspection"](#).

OK or NG

- OK (With CONSULT-II)>>GO TO 6.
OK (Without CONSULT-II)>>GO TO 7.
NG >> Replace EVAP control system pressure sensor.

6. CHECK EVAP CANISTER PURGE VOLUME CONTROL SOLENOID VALVE

 **With CONSULT-II**

1. Turn ignition switch OFF.
2. Reconnect harness connectors disconnected.
3. Start engine.
4. Perform "PURG VOL CONT/V" in "ACTIVE TEST" mode with CONSULT-II. Check that engine speed varies according to the valve opening.

OK or NG

- OK >> GO TO 8.
NG >> GO TO 7.

ACTIVE TEST	
PURG VOL CONT/V	0 %
MONITOR	
ENG SPEED	XXX rpm
HO2S1 MNTR (B1)	LEAN
HO2S1 MNTR (B2)	LEAN
A/F ALPHA-B1	XXX %
A/F ALPHA-B2	XXX %

PBIB0147E

7. CHECK EVAP CANISTER PURGE VOLUME CONTROL SOLENOID VALVE

Refer to [EC-1167, "Component Inspection"](#).

OK or NG

- OK >> GO TO 8.
NG >> Replace EVAP canister purge volume control solenoid valve.

8. CHECK RUBBER TUBE FOR CLOGGING

1. Disconnect rubber tube connected to EVAP canister vent control valve.
2. Check the rubber tube for clogging.

OK or NG

- OK >> GO TO 9.
NG >> Clean the rubber tube using an air blower.

9. CHECK EVAP CANISTER VENT CONTROL VALVE

Refer to [EC-1002, "Component Inspection"](#).

OK or NG

- OK >> GO TO 10.
NG >> Replace EVAP canister vent control valve.

DTC P1444 EVAP CANISTER PURGE VOLUME CONTROL SOLENOID VALVE [VK45DE]

10. CHECK IF EVAP CANISTER SATURATED WITH WATER

1. Remove EVAP canister with EVAP canister vent control valve and EVAP control system pressure sensor attached.
2. Check if water will drain from the EVAP canister.

Yes or No

Yes >> GO TO 11.

No >> GO TO 13.

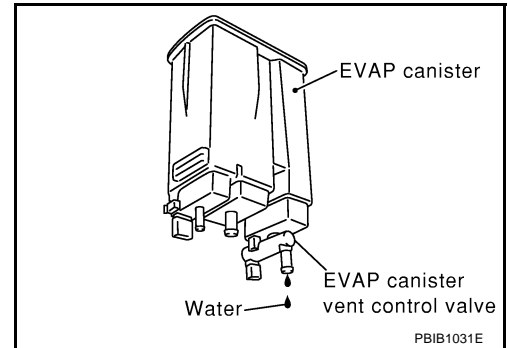

11. CHECK EVAP CANISTER

Weigh the EVAP canister with the EVAP canister vent control valve and EVAP control system pressure sensor attached.

The weight should be less than 2.1 kg (4.6 lb).

OK or NG

OK >> GO TO 13.

NG >> GO TO 12.

12. DETECT MALFUNCTIONING PART

Check the following.

- EVAP canister for damage
- EVAP hose between EVAP canister and vehicle frame for clogging or poor connection

>> Repair hose or replace EVAP canister.

13. CHECK INTERMITTENT INCIDENT

Refer to [EC-784, "TROUBLE DIAGNOSIS FOR INTERMITTENT INCIDENT"](#) .

>> **INSPECTION END**

DTC P1444 EVAP CANISTER PURGE VOLUME CONTROL SOLENOID VALVE [VK45DE]

ABS00CBI

Component Inspection

EVAP CANISTER PURGE VOLUME CONTROL SOLENOID VALVE

With CONSULT-II

Check air passage continuity of EVAP canister purge volume control solenoid valve under the following conditions.

Condition (PURG VOL CONT/V value)	Air passage continuity between A and B
100%	Yes
0%	No

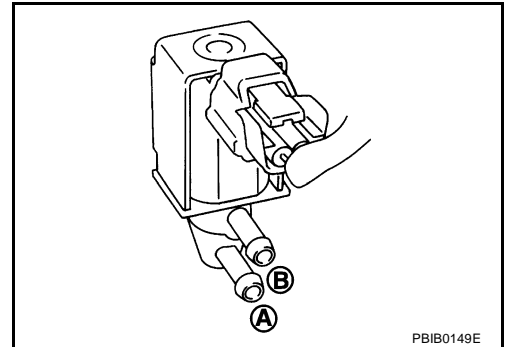

Without CONSULT-II

Check air passage continuity of EVAP canister purge volume control solenoid valve under the following conditions.

Condition	Air passage continuity between A and B
12V direct current supply between terminals 1 and 2	Yes
No supply	No

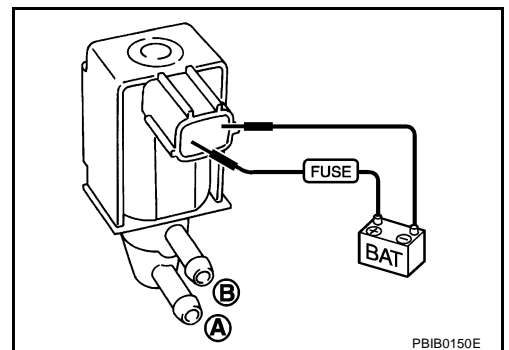

Removal and Installation

EVAP CANISTER PURGE VOLUME CONTROL SOLENOID VALVE

Refer to [EM-174, "INTAKE MANIFOLD"](#).

ABS00CBJ

DTC P1446 EVAP CANISTER VENT CONTROL VALVE

PFP:14935

Component Description

ABS00CBK

The EVAP canister vent control valve is located on the EVAP canister and is used to seal the canister vent.

This solenoid valve responds to signals from the ECM. When the ECM sends an ON signal, the coil in the solenoid valve is energized. A plunger will then move to seal the canister vent. The ability to seal the vent is necessary for the on board diagnosis of other evaporative emission control system components.

This solenoid valve is used only for diagnosis, and usually remains opened.

When the vent is closed, under normal purge conditions, the evaporative emission control system is depressurized and allows EVAP Control System diagnosis.

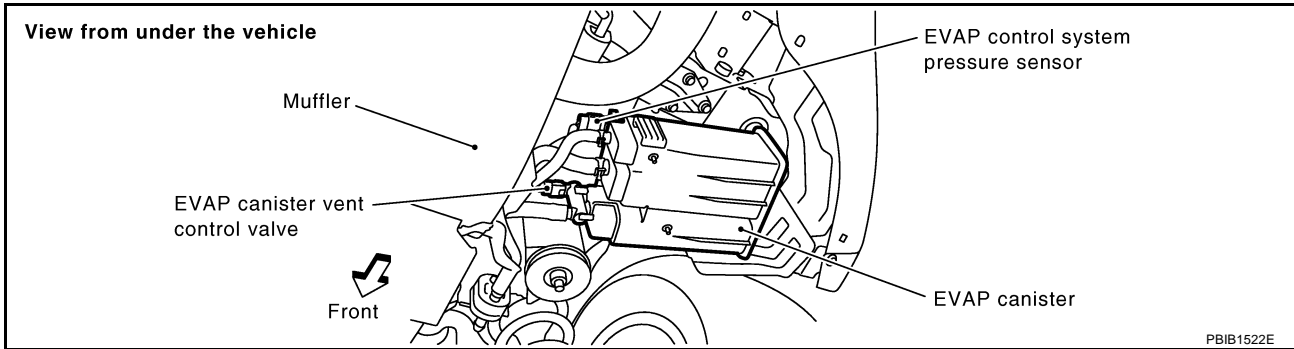
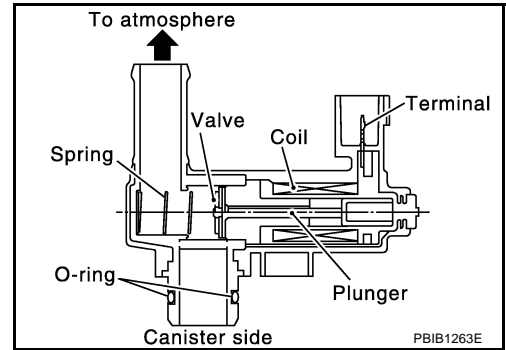

CONSULT-II Reference Value in Data Monitor Mode

ABS00CBL

Specification data are reference values.

MONITOR ITEM	CONDITION	SPECIFICATION
VENT CONT/V	● Ignition switch: ON	OFF

On Board Diagnosis Logic

ABS00CBM

DTC No.	Trouble diagnosis name	DTC detecting condition	Possible cause
P1446 1446	EVAP canister vent control valve close	EVAP canister vent control valve remains closed under specified driving conditions.	<ul style="list-style-type: none"> ● EVAP canister vent control valve ● EVAP control system pressure sensor and the circuit ● Blocked rubber tube to EVAP canister vent control valve ● EVAP canister is saturated with water

DTC Confirmation Procedure

NOTE:

If DTC Confirmation Procedure has been previously conducted, always turn ignition switch OFF and wait at least 10 seconds before conducting the next test.

Ⓟ WITH CONSULT-II

1. Turn ignition switch ON and wait at least 5 seconds.
2. Turn ignition switch OFF and wait at least 10 seconds.
3. Turn ignition switch ON and select "DATA MONITOR" mode with CONSULT-II.
4. Start engine and let it idle for at least 1 minute.
5. Repeat next procedures 3 times.
 - a. Increase the engine speed up to 3,000 to 3,500 rpm and keep it for 2 minutes and 50 seconds to 3 minutes.
Never exceed 3 minutes.
 - b. Fully released accelerator pedal and keep engine idle for about 5 seconds.
6. If 1st trip DTC is detected, go to [EC-1171, "Diagnostic Procedure"](#).
If 1st trip DTC is not detected, go to the next step.
7. Repeat next procedure 20 times.
 - a. Quickly increase the engine speed up to 4,000 to 4,500 rpm or more and keep it for 25 to 30 seconds.
 - b. Fully released accelerator pedal and keep engine idle for at least 35 seconds.

DATA MONITOR	
MONITOR	NO DTC
ENG SPEED	XXX rpm

SEF058Y

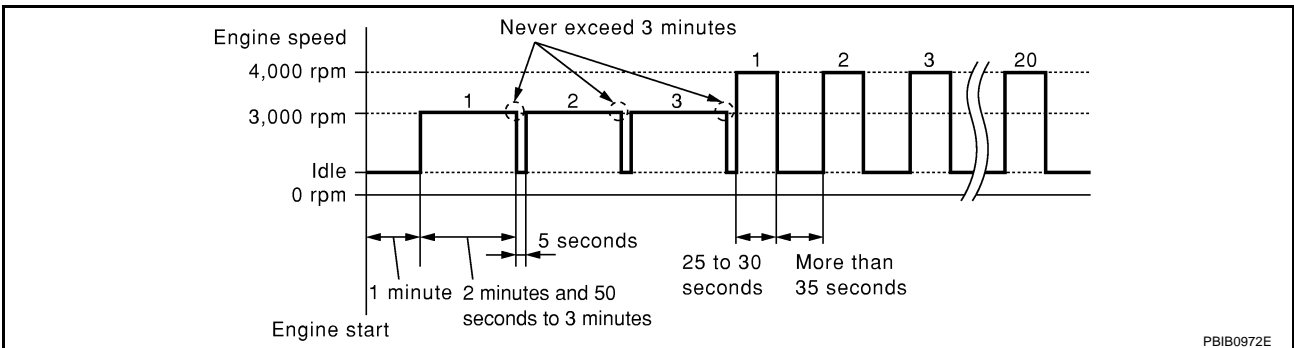

8. If 1st trip DTC is detected, go to [EC-1171, "Diagnostic Procedure"](#).

Ⓢ WITH GST

Follow the procedure "WITH CONSULT-II" above.

A
EC
C
D
E
F
G
H
I
J
K
L
M

DTC P1446 EVAP CANISTER VENT CONTROL VALVE

[VK45DE]

ABS00CBO

Wiring Diagram

EC-VENT/V-01

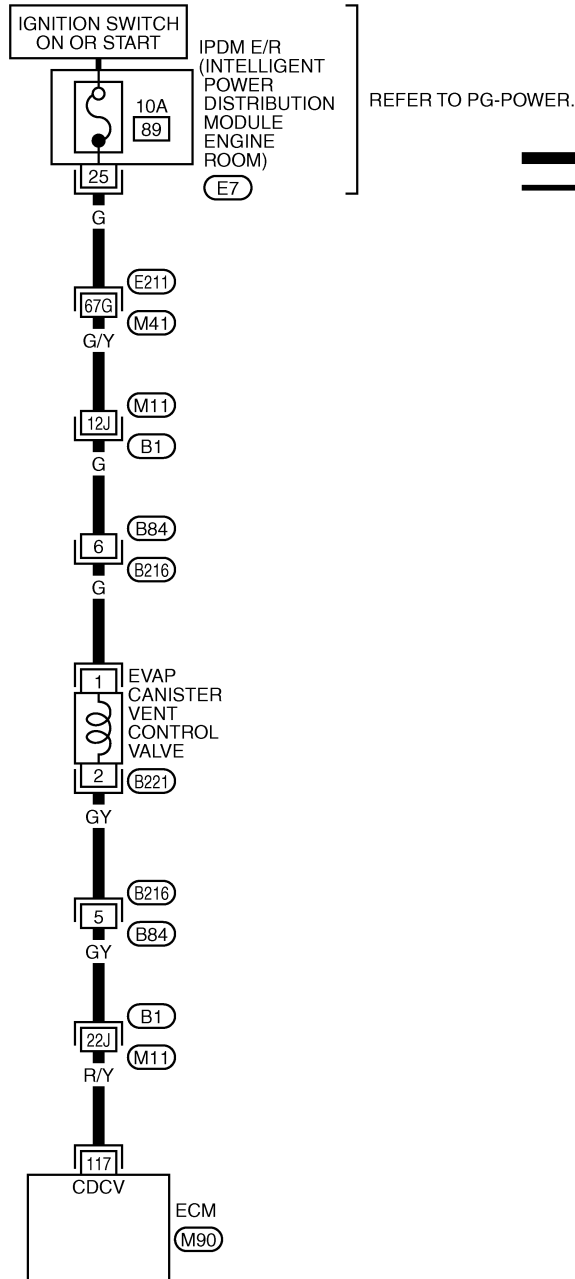

: DETECTABLE LINE FOR DTC
 : NON-DETECTABLE LINE FOR DTC

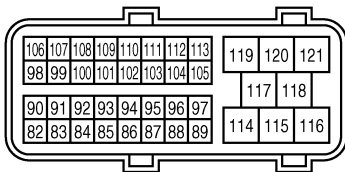

(M90)
B

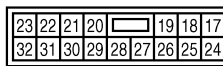

(E7)
GY



(B216)
GY

(B221)
B

REFER TO THE FOLLOWING.

(E211), (B1) -SUPER MULTIPLE JUNCTION (SMJ)

TBWH0110E

DTC P1446 EVAP CANISTER VENT CONTROL VALVE

[VK45DE]

Specification data are reference values and are measured between each terminal and ground.

CAUTION:

Do not use ECM ground terminals when measuring input/output voltage. Doing so may result in damage to the ECM's transistor. Use a ground other than ECM terminals, such as the ground.

TER-MINAL NO.	WIRE COLOR	ITEM	CONDITION	DATA (DC Voltage)
117	R/Y	EVAP canister vent control valve	[Ignition switch: ON]	BATTERY VOLTAGE (11 - 14V)

Diagnostic Procedure

ABS00CBP

1. CHECK RUBBER TUBE

1. Turn ignition switch OFF.
2. Disconnect rubber tube connected to EVAP canister vent control valve.

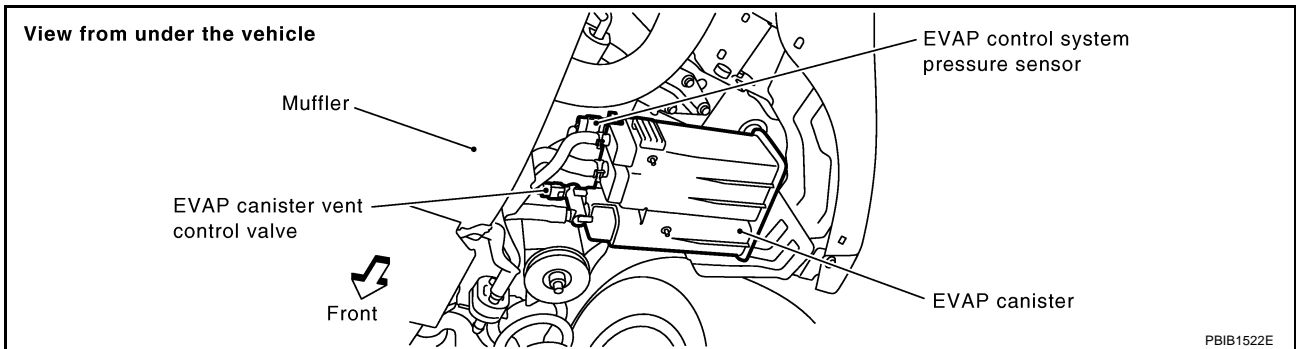

3. Check the rubber tube for clogging.

OK or NG

- OK >> GO TO 2.
- NG >> Clean rubber tube using an air blower.

2. CHECK EVAP CANISTER VENT CONTROL VALVE

Refer to [EC-1172, "EVAP CANISTER VENT CONTROL VALVE"](#).

OK or NG

- OK >> GO TO 3.
- NG >> Replace EVAP canister vent control valve.

3. CHECK IF EVAP CANISTER SATURATED WITH WATER

1. Remove EVAP canister with EVAP canister vent control valve and EVAP control system pressure sensor attached.
2. Check if water will drain from the EVAP canister.

Yes or No

- Yes >> GO TO 4.
- No >> GO TO 6.

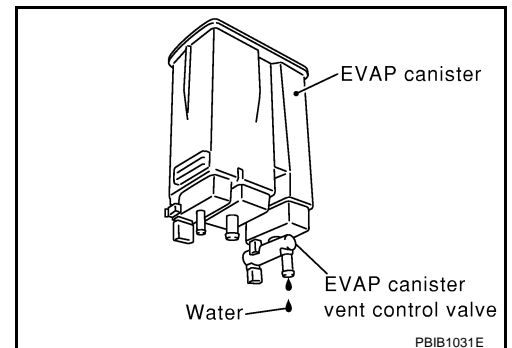

4. CHECK EVAP CANISTER

Weigh the EVAP canister with the EVAP canister vent control valve and EVAP control system pressure sensor attached.

The weight should be less than 2.1 kg (4.6 lb).

OK or NG

- OK >> GO TO 6.
- NG >> GO TO 5.

5. DETECT MALFUNCTIONING PART

Check the following.

- EVAP canister for damage
- EVAP hose between EVAP canister and vehicle frame for clogging or poor connection

>> Repair hose or replace EVAP canister.

6. CHECK EVAP CONTROL SYSTEM PRESSURE SENSOR CONNECTOR

1. Disconnect EVAP control system pressure sensor harness connector.
2. Check connectors for water.

Water should not exist.

OK or NG

- OK >> GO TO 7.
- NG >> Replace EVAP control system pressure sensor.

7. CHECK EVAP CONTROL SYSTEM PRESSURE SENSOR

Refer to [EC-1013, "Component Inspection"](#) .

OK or NG

- OK >> GO TO 8.
- NG >> Replace EVAP control system pressure sensor.

8. CHECK INTERMITTENT INCIDENT

Refer to [EC-784, "TROUBLE DIAGNOSIS FOR INTERMITTENT INCIDENT"](#) .

>> **INSPECTION END**

Component Inspection EVAP CANISTER VENT CONTROL VALVE

ABS00CBQ

④ With CONSULT-II

1. Remove EVAP canister vent control valve from EVAP canister.
2. Check portion **B** of EVAP canister vent control valve for being rusted.
If NG, replace EVAP canister vent control valve.
If OK, go to next step.
3. Reconnect harness connectors disconnected.
4. Turn ignition switch ON.

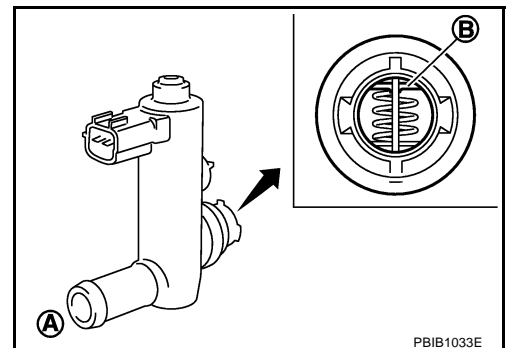

PBIB1033E

DTC P1446 EVAP CANISTER VENT CONTROL VALVE

[VK45DE]

5. Perform "VENT CONTROL/V" in "ACTIVE TEST" mode.
6. Check air passage continuity and operation delay time.
Make sure that new O-ring is installed properly.

Condition VENT CONTROL/V	Air passage continuity between A and B
ON	No
OFF	Yes

Operation takes less than 1 second.

If NG, replace EVAP canister vent control valve.
If OK, go to next step.

7. Clean the air passage (Portion **A** to **B**) of EVAP canister vent control valve using an air blower.
8. Perform step 6 again.

⊗ **Without CONSULT-II**

1. Remove EVAP canister vent control valve from EVAP canister.
2. Check portion **B** of EVAP canister vent control valve for being rusted.

ACTIVE TEST	
VENT CONTROL/V	OFF
MONITOR	
ENG SPEED	XXX rpm
A/F ALPHA-B1	XXX %
A/F ALPHA-B2	XXX %
HO2S1 (B1)	XXX V
HO2S1 (B2)	XXX V

PBIB0151E

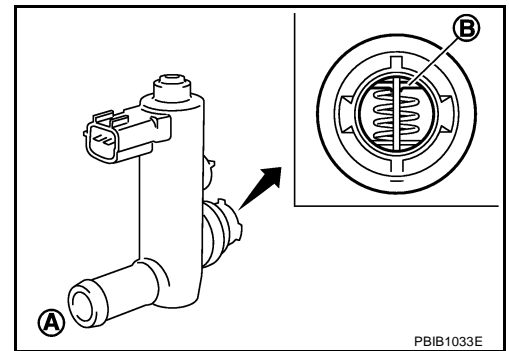

3. Check air passage continuity and operation delay time under the following conditions.
Make sure that new O-ring is installed properly.

Condition	Air passage continuity between A and B
12V direct current supply between terminals 1 and 2	No
OFF	Yes

Operation takes less than 1 second.

If NG, replace EVAP canister vent control valve.
If OK, go to next step.

4. Clean the air passage (Portion **A** to **B**) of EVAP canister vent control valve using an air blower.
5. Perform step 3 again.

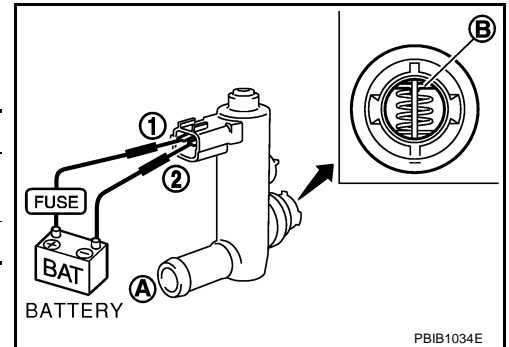

DTC P1564 ICC STEERING SWITCH

[VK45DE]

DTC P1564 ICC STEERING SWITCH

PFP:25551

Component Description

ABS00CBR

ICC steering switch has variant values of electrical resistance for each button. ECM reads voltage variation of switch, and determines which button is operated.

Refer to [ACS-6, "DESCRIPTION"](#) for the ICC function.

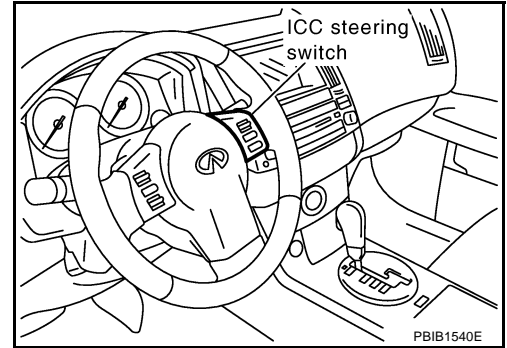

CONSULT-II Reference Value in Data Monitor Mode

ABS00CBS

Specification data are reference values.

MONITOR ITEM	CONDITION		SPECIFICATION
MAIN SW	● Ignition switch: ON	● ON/OFF (MAIN) switch: Pressed	ON
		● ON/OFF (MAIN) switch: Released	OFF
CANCEL	● Ignition switch: ON	● CANCEL switch: Pressed	ON
		● CANCEL switch: Released	OFF
RESUME/ACC SW	● Ignition switch: ON	● ACCEL/RESUME switch: Pressed	ON
		● ACCEL/RESUME switch: Released	OFF
SET SW	● Ignition switch: ON	● COAST/SET switch: Pressed	ON
		● COAST/SET switch: Released	OFF
DIST SW	● Ignition switch: ON	● DISTANCE switch: Pressed	ON
		● DISTANCE switch: Released	OFF

On Board Diagnosis Logic

ABS00CBT

This self-diagnosis has the one trip detection logic.

The MIL will not light up for this diagnosis.

NOTE:

If DTC P1564 is displayed with DTC P0605, first perform the trouble diagnosis for DTC P0605. Refer to [EC-1057](#).

DTC No.	Trouble diagnosis name	DTC detecting condition	Possible cause
P1564 1564	ICC steering switch	<ul style="list-style-type: none"> ● An excessively high voltage signal from the ICC steering switch is sent to ECM. ● ECM detects that input signal from the ICC steering switch is out of the specified range. ● ECM detects that the ICC steering switch is stuck ON. 	<ul style="list-style-type: none"> ● Harness or connectors (The switch circuit is open or shorted.) ● ICC steering switch ● ECM

DTC Confirmation Procedure

ABS00CBU

NOTE:

If DTC Confirmation Procedure has been previously conducted, always turn ignition switch OFF and wait at least 10 seconds before conducting the next test.

DTC P1564 ICC STEERING SWITCH

[VK45DE]

WITH CONSULT-II

1. Turn ignition switch ON.
2. Select "DATA MONITOR" mode with CONSULT-II.
3. Wait at least 10 seconds.
4. Press ON/OFF (MAIN) switch for at least 10 seconds, then release it and wait at least 10 seconds.
5. Press ACCEL/RESUME switch for at least 10 seconds, then release it and wait at least 10 seconds.
6. Press COAST/SET switch for at least 10 seconds, then release it and wait at least 10 seconds.
7. Press DISTANCE switch for at least 10 seconds, then release it and wait at least 10 seconds.
8. Press CANCEL switch for at least 10 seconds, then release it and wait at least 10 seconds.
9. If DTC is detected, go to [EC-1177, "Diagnostic Procedure"](#) .

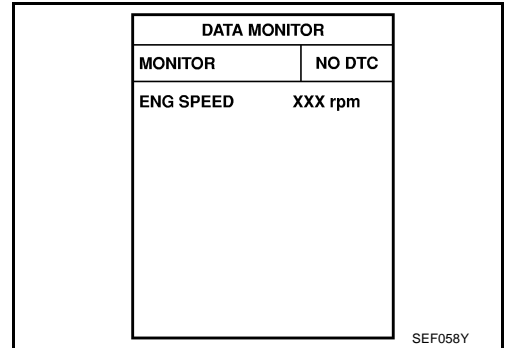

DATA MONITOR	
MONITOR	NO DTC
ENG SPEED	XXX rpm

SEF058Y

WITH GST

Follow the procedure "WITH CONSULT-II" above.

A
EC
C
D
E
F
G
H
I
J
K
L
M

DTC P1564 ICC STEERING SWITCH

[VK45DE]

Wiring Diagram

ABS00CBV

EC-ICC/SW-01

: DETECTABLE LINE FOR DTC
 : NON-DETECTABLE LINE FOR DTC

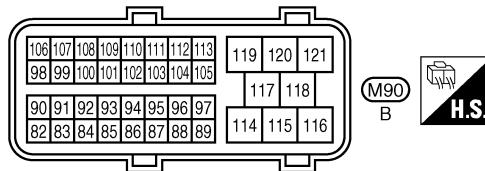
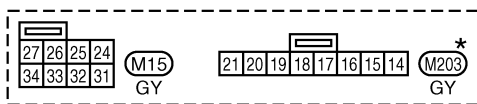
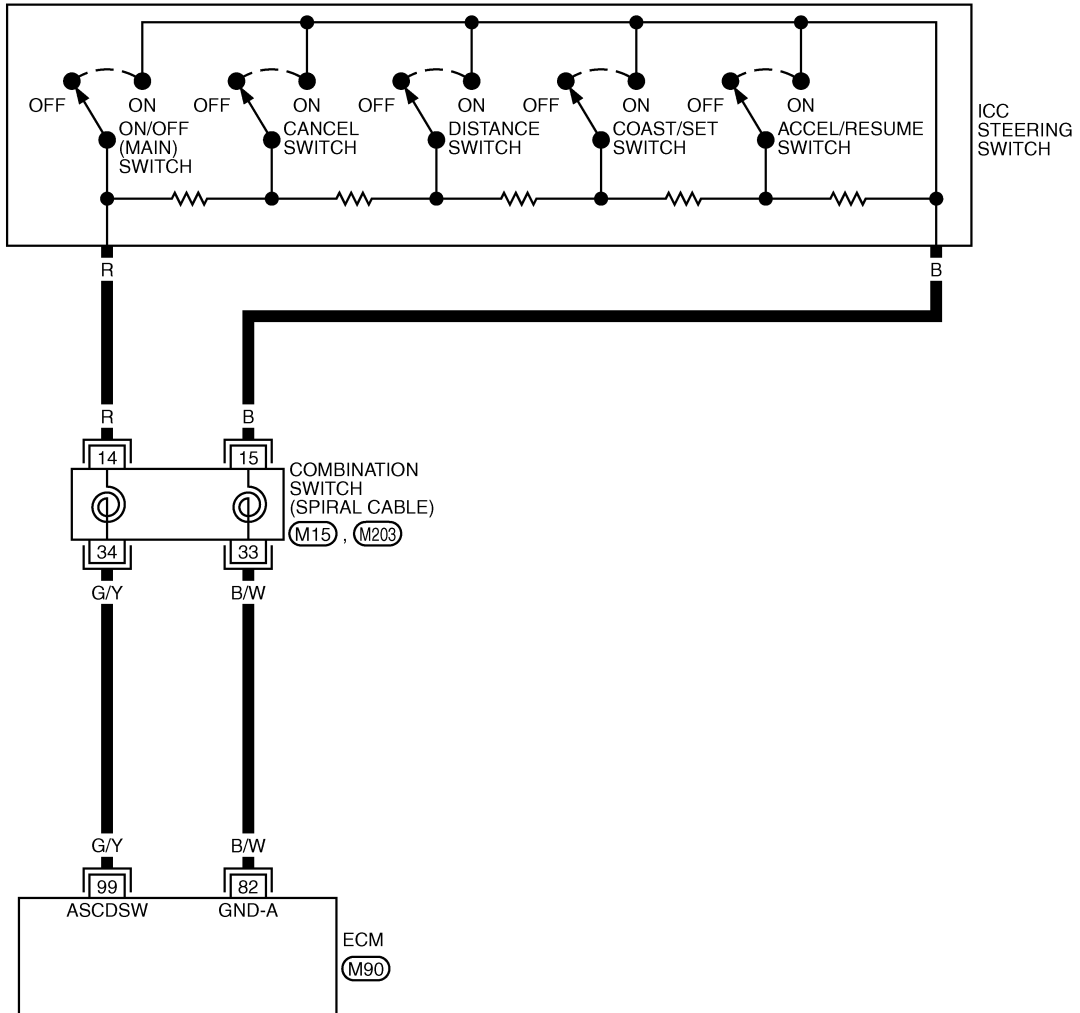

*: THIS CONNECTOR IS NOT SHOWN IN "HARNESS LAYOUT", PG SECTION.

TBWM0273E

DTC P1564 ICC STEERING SWITCH

[VK45DE]

Specification data are reference values and are measured between each terminal and ground.

CAUTION:

Do not use ECM ground terminals when measuring input/output voltage. Doing so may result in damage to the ECM's transistor. Use a ground other than ECM terminals, such as the ground.

TERMI- NAL NO.	WIRE COLOR	ITEM	CONDITION	DATA (DC Voltage)
82	B/W	Sensor ground (APP sensor 1 / ICC steering switch)	[Engine is running] ● Warm-up condition ● Idle speed	Approximately 0V
99	G/Y	ICC steering switch	[Ignition switch: ON] ● ICC steering switch: OFF	Approximately 4.3V
			[Ignition switch: ON] ● ON/OFF (MAIN) switch: Pressed	Approximately 0V
			[Ignition switch: ON] ● CANCEL switch: Pressed	Approximately 1.3V
			[Ignition switch: ON] ● DISTANCE switch: Pressed	Approximately 2.2V
			[Ignition switch: ON] ● COAST/SET switch: Pressed	Approximately 3V
			[Ignition switch: ON] ● ACCEL/RESUME switch: Pressed	Approximately 3.7V

Diagnostic Procedure

ABS00CBW

1. CHECK GROUND CONNECTIONS

1. Turn ignition switch OFF.
2. Loosen and retighten three ground screws on the body.
Refer to [EC-791, "Ground Inspection"](#).

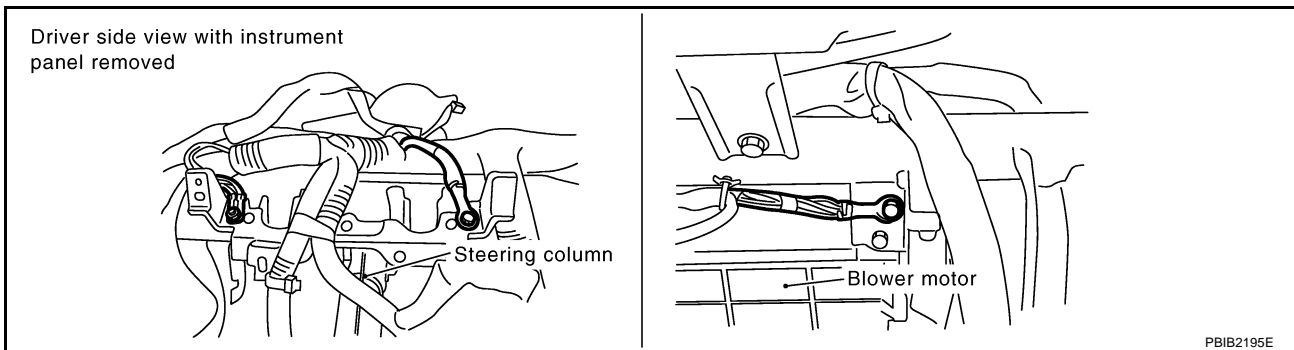

PBIB2195E

OK or NG

- OK >> GO TO 2.
- NG >> Repair or replace ground connections.

2. CHECK ICC STEERING SWITCH CIRCUIT

☑ With CONSULT-II

1. Turn ignition switch ON.
2. Select "MAIN SW", "RESUME/ACC SW", "SET SW", "DIST SW" and "CANCEL SW" in "DATA MONITOR" mode with CONSULT-II.
3. Check each item indication under the following conditions.

DATA MONITOR	
MONITOR	NO DTC
MAIN SW	OFF
CANCEL SW	OFF
RESUME/ACC SW	OFF
SET SW	OFF
DIST SW	OFF

MBIB0064E

Switch	Monitor item	Condition	Indication
ON/OFF (MAIN) switch	MAIN SW	Pressed	ON
		Released	OFF
ACCEL/RESUME switch	RESUME/ACC SW	Pressed	ON
		Released	OFF
COAST/SET switch	SET SW	Pressed	ON
		Released	OFF
DISTANCE switch	DIST SW	Pressed	ON
		Released	OFF
CANCEL switch	CANCEL SW	Pressed	ON
		Released	OFF

☒ Without CONSULT-II

1. Turn ignition switch ON.
2. Check voltage between ECM terminal 99 and ground with pressing each button.

Switch	Condition	Voltage [V]
ON/OFF (MAIN) switch	Pressed	Approx. 0
	Released	Approx. 4.3
ACCEL/RESUME switch	Pressed	Approx. 3.7
	Released	Approx. 4.3
COAST/SET switch	Pressed	Approx. 3.0
	Released	Approx. 4.3
DISTANCE switch	Pressed	Approx. 2.2
	Released	Approx. 4.3
CANCEL switch	Pressed	Approx. 1.3
	Released	Approx. 4.3

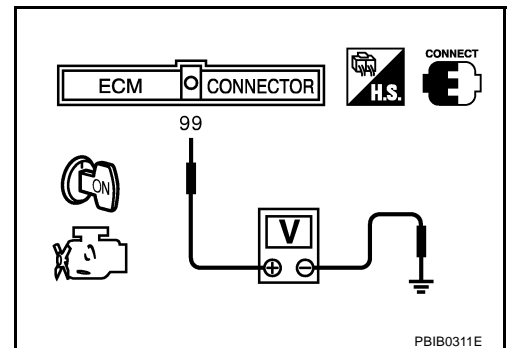

OK or NG

- OK >> GO TO 8.
 NG >> GO TO 3.

3. CHECK ICC STEERING SWITCH GROUND CIRCUIT FOR OPEN AND SHORT

1. Turn ignition switch OFF.
2. Disconnect ECM harness connector.
3. Disconnect combination switch harness connector.
4. Check harness continuity between combination switch terminal 15 and ECM terminal 82.
Refer to Wiring Diagram.

Continuity should exist.

5. Also check harness for short to ground and short to power.

OK or NG

- OK >> GO TO 5.
NG >> GO TO 4.

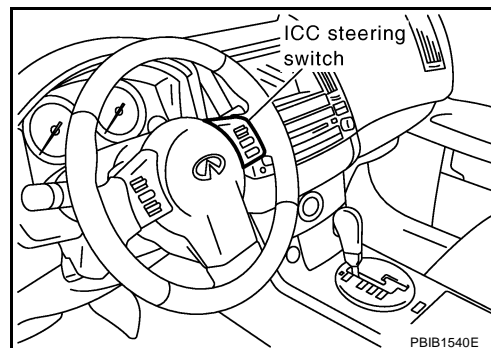

4. DETECT MALFUNCTIONING PART

Check the following.

- Combination switch (spiral cable)
- Harness for open and short between ECM and combination switch

>> Repair open circuit or short to ground or short to power in harness or connectors.

5. CHECK ICC STEERING SWITCH INPUT SIGNAL CIRCUIT FOR OPEN AND SHORT

1. Check harness continuity between ECM terminal 99 and combination switch terminal 14.
Refer to Wiring Diagram.

Continuity should exist.

2. Also check harness for short to ground and short to power.

OK or NG

- OK >> GO TO 7.
NG >> GO TO 6.

6. DETECT MALFUNCTIONING PART

Check the following.

- Combination switch (spiral cable)
- Harness for open and short between ECM and combination switch

>> Repair open circuit or short to ground or short to power in harness or connectors.

7. CHECK ICC STEERING SWITCH

Refer to [EC-1180, "Component Inspection"](#).

OK or NG

- OK >> GO TO 8.
NG >> Replace ICC steering switch.

8. CHECK INTERMITTENT INCIDENT

Refer to [EC-784, "TROUBLE DIAGNOSIS FOR INTERMITTENT INCIDENT"](#).

>> **INSPECTION END**

DTC P1564 ICC STEERING SWITCH

[VK45DE]

ABS00CBX

Component Inspection ICC STEERING SWITCH

1. Disconnect combination switch (spiral cable).
2. Check continuity between combination switch (spiral cable) terminals 14 and 15 with pushing each switch.

Switch	Condition	Resistance [Ω]
ON/OFF (MAIN) switch	Pressed	Approx. 0
	Released	Approx. 5,500
ACCEL/RESUME switch	Pressed	Approx. 2,600
	Released	Approx. 5,500
COAST/SET switch	Pressed	Approx. 1,400
	Released	Approx. 5,500
DISTANCE switch	Pressed	Approx. 740
	Released	Approx. 5,500
CANCEL switch	Pressed	Approx. 310
	Released	Approx. 5,500

If NG, replace ICC steering switch.

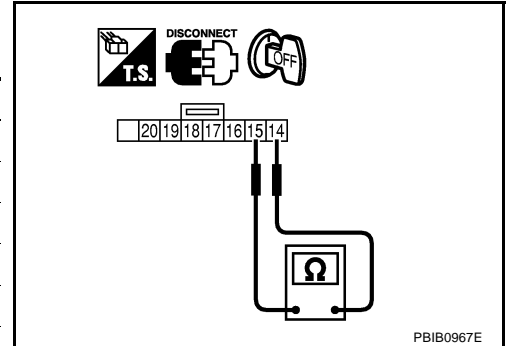

DTC P1564 ASCD STEERING SWITCH

PPF:25551

Component Description

ABS00CBY

ASCD steering switch has variant values of electrical resistance for each button. ECM reads voltage variation of switch, and determines which button is operated.

Refer to [EC-1334, "AUTOMATIC SPEED CONTROL DEVICE \(ASCD\)"](#) for the ASCD function.

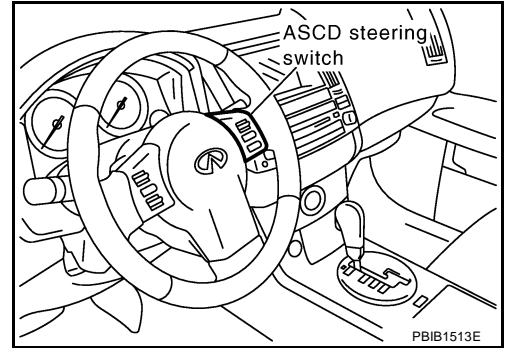

CONSULT-II Reference Value in Data Monitor Mode

ABS00CBZ

Specification data are reference values.

MONITOR ITEM	CONDITION		SPECIFICATION
MAIN SW	● Ignition switch: ON	ON/OFF (MAIN) switch: Pressed	ON
		ON/OFF (MAIN) switch: Released	OFF
CANCEL SW	● Ignition switch: ON	CANCEL switch: Pressed	ON
		CANCEL switch: Released	OFF
RESUME/ACC SW	● Ignition switch: ON	ACCEL/RESUME switch: Pressed	ON
		ACCEL/RESUME switch: Released	OFF
SET SW	● Ignition switch: ON	COAST/SET switch: Pressed	ON
		COAST/SET switch: Released	OFF

On Board Diagnosis Logic

ABS00CC0

This self-diagnosis has the one trip detection logic.

The MIL will not light up for this diagnosis.

NOTE:

If DTC P1564 is displayed with DTC P0605, first perform the trouble diagnosis for DTC P0605. Refer to [EC-1057](#).

DTC No.	Trouble diagnosis name	DTC detecting condition	Possible cause
P1564 1564	ASCD steering switch	<ul style="list-style-type: none"> ● An excessively high voltage signal from the ASCD steering switch is sent to ECM. ● ECM detects that input signal from the ASCD steering switch is out of the specified range. ● ECM detects that the ASCD steering switch is stuck ON. 	<ul style="list-style-type: none"> ● Harness or connectors (The switch circuit is open or shorted.) ● ASCD steering switch ● ECM

DTC Confirmation Procedure

NOTE:

If DTC Confirmation Procedure has been previously conducted, always turn ignition switch OFF and wait at least 10 seconds before conducting the next test.

WITH CONSULT-II

1. Turn ignition switch ON.
2. Select "DATA MONITOR" mode with CONSULT-II.
3. Wait at least 10 seconds.
4. Press ON/OFF (MAIN) switch for at least 10 seconds, then release it and wait at least 10 seconds.
5. Press ACCEL/RESUME switch for at least 10 seconds, then release it and wait at least 10 seconds.
6. Press COAST/SET switch for at least 10 seconds, then release it and wait at least 10 seconds.
7. Press CANCEL switch for at least 10 seconds, then release it and wait at least 10 seconds.
8. If DTC is detected, go to [EC-1184, "Diagnostic Procedure"](#) .

WITH GST

Follow the procedure "WITH CONSULT-II" above.

DTC P1564 ASCD STEERING SWITCH

[VK45DE]

Wiring Diagram

ABS00CC2

EC-ASC/SW-01

— : DETECTABLE LINE FOR DTC
— : NON-DETECTABLE LINE FOR DTC

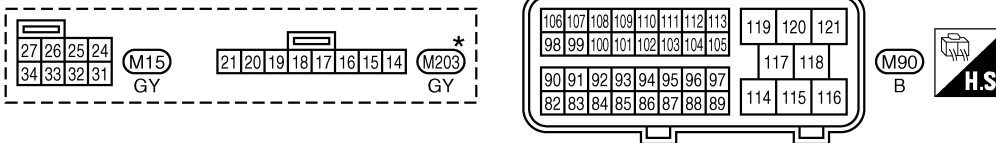
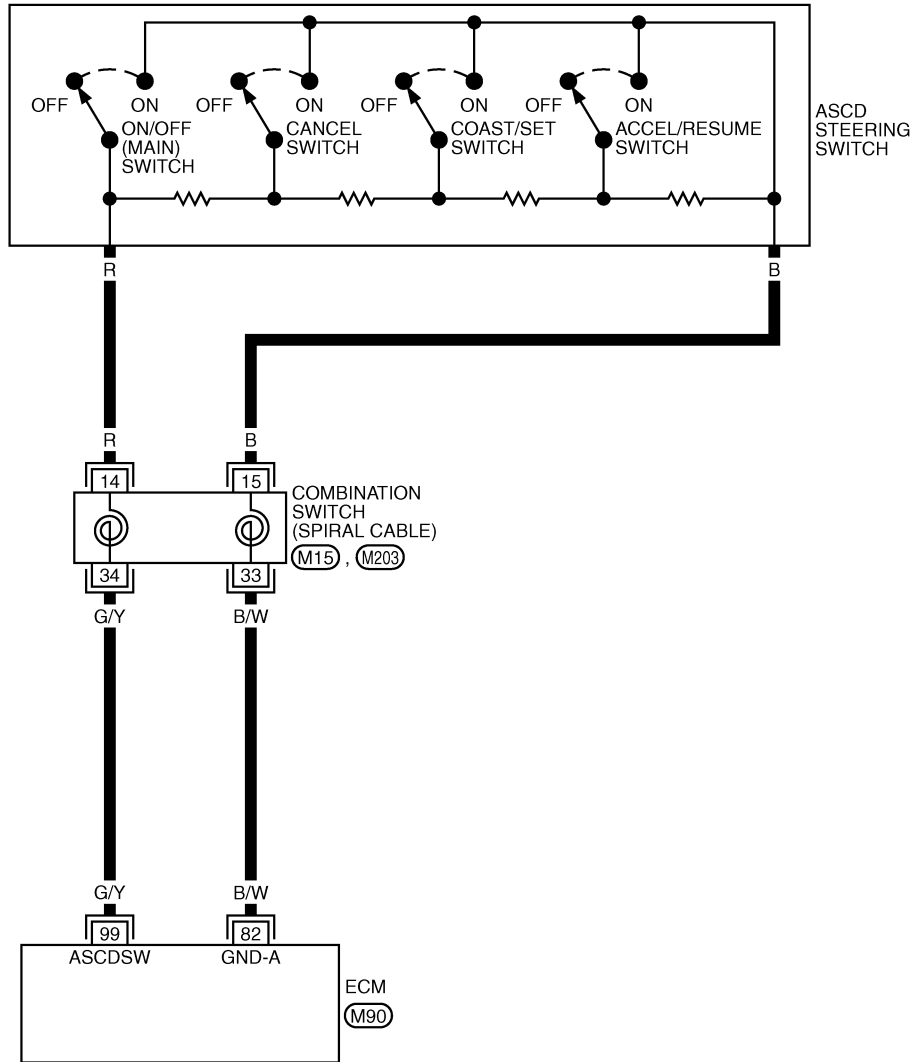

*: THIS CONNECTOR IS NOT SHOWN IN "HARNESS LAYOUT", PG SECTION.

DTC P1564 ASCD STEERING SWITCH

[VK45DE]

Specification data are reference values and are measured between each terminal and ground.

CAUTION:

Do not use ECM ground terminals when measuring input/output voltage. Doing so may result in damage to the ECM's transistor. Use a ground other than ECM terminals, such as the ground.

TER-MINAL NO.	WIRE COLOR	ITEM	CONDITION	DATA (DC Voltage)
82	B/W	Sensor ground (APP sensor 1 / ASCD steering switch)	[Engine is running] <ul style="list-style-type: none"> ● Warm-up condition ● Idle speed 	Approximately 0V
99	G/Y	ASCDC steering switch	[Ignition switch: ON] <ul style="list-style-type: none"> ● ASCD steering switch: OFF 	Approximately 4V
			[Ignition switch "ON"] <ul style="list-style-type: none"> ● ON/OFF (MAIN) switch: Pressed 	Approximately 0V
			[Ignition switch: ON] <ul style="list-style-type: none"> ● CANCEL switch: Pressed 	Approximately 1V
			[Ignition switch: ON] <ul style="list-style-type: none"> ● COAST/SET switch: Pressed 	Approximately 2V
			[Ignition switch: ON] <ul style="list-style-type: none"> ● ACCEL/RESUME switch: Pressed 	Approximately 3V

Diagnostic Procedure

ABS00CC3

1. CHECK GROUND CONNECTIONS

1. Turn ignition switch OFF.
2. Loosen and retighten three ground screws on the body.
Refer to [EC-791, "Ground Inspection"](#).

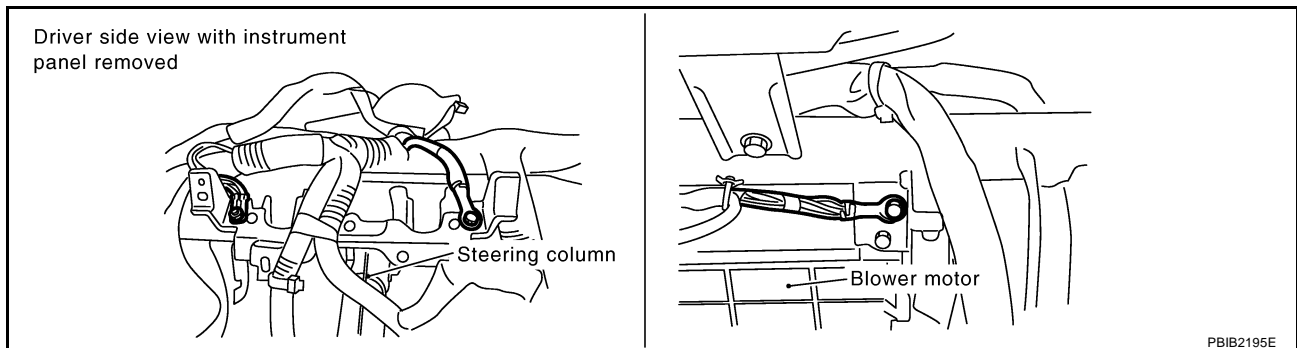

PBIB2195E

OK or NG

- OK >> GO TO 2.
- NG >> Repair or replace ground connections.

2. CHECK ASCD STEERING SWITCH CIRCUIT

☑ With CONSULT-II

1. Turn ignition switch ON.
2. Select "MAIN SW", "RESUME/ACC SW", "SET SW" and "CANCEL SW" in "DATA MONITOR" mode with CONSULT-II.
3. Check each item indication under the following conditions.

Switch	Monitor item	Condition	Indication
ON/OFF (MAIN) switch	MAIN SW	Pressed	ON
		Released	OFF
ACCEL/RESUME switch	RESUME/ACC SW	Pressed	ON
		Released	OFF
COAST/SET switch	SET SW	Pressed	ON
		Released	OFF
CANCEL switch	CANCEL SW	Pressed	ON
		Released	OFF

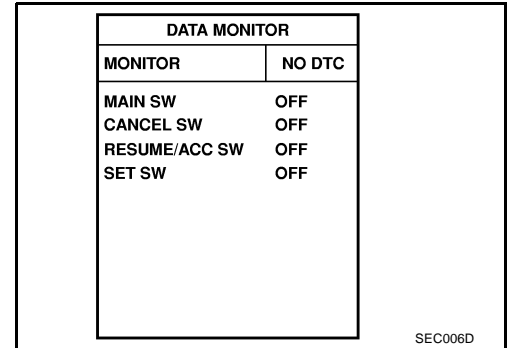

⊗ Without CONSULT-II

1. Turn ignition switch ON.
2. Check voltage between ECM terminal 99 and ground with pressing each button.

Switch	Condition	Voltage [V]
ON/OFF (MAIN) switch	Pressed	Approx. 0
	Released	Approx. 4
ACCEL/RESUME switch	Pressed	Approx. 3
	Released	Approx. 4
COAST/SET switch	Pressed	Approx. 2
	Released	Approx. 4
CANCEL switch	Pressed	Approx. 1
	Released	Approx. 4

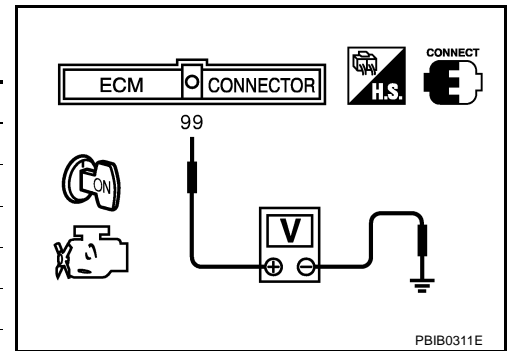

OK or NG

- OK >> GO TO 8.
 NG >> GO TO 3.

3. CHECK ASCD STEERING SWITCH GROUND CIRCUIT FOR OPEN AND SHORT

1. Turn ignition switch OFF.
2. Disconnect ECM harness connector.
3. Disconnect combination switch harness connector.
4. Check harness continuity between combination switch terminal 15 and ECM terminal 82. Refer to Wiring Diagram.

Continuity should exist.

5. Also check harness for short to ground and short to power.

OK or NG

- OK >> GO TO 5.
 NG >> GO TO 4.

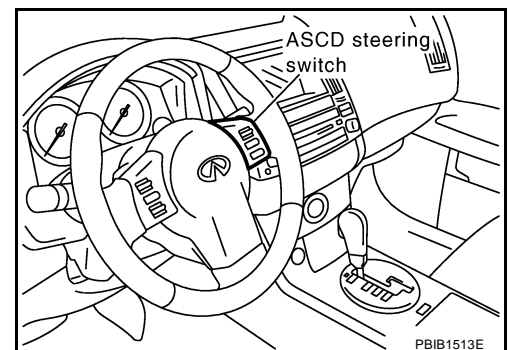

4. DETECT MALFUNCTIONING PART

Check the following.

- Combination switch (spiral cable)
- Harness for open and short between ECM and combination switch

>> Repair open circuit or short to ground or short to power in harness or connectors.

5. CHECK ASCD STEERING SWITCH INPUT SIGNAL CIRCUIT FOR OPEN AND SHORT

1. Check harness continuity between ECM terminal 99 and combination switch terminal 14.
Refer to Wiring Diagram.

Continuity should exist.

2. Also check harness for short to ground and short to power.

OK or NG

OK >> GO TO 7.

NG >> GO TO 6.

6. DETECT MALFUNCTIONING PART

Check the following.

- Combination switch (spiral cable)
- Harness for open and short between ECM and combination switch

>> Repair open circuit or short to ground or short to power in harness or connectors.

7. CHECK ASCD STEERING SWITCH

Refer to [EC-1187, "Component Inspection"](#) .

OK or NG

OK >> GO TO 8.

NG >> Replace ASCD steering switch.

8. CHECK INTERMITTENT INCIDENT

Refer to [EC-784, "TROUBLE DIAGNOSIS FOR INTERMITTENT INCIDENT"](#) .

>> **INSPECTION END**

DTC P1564 ASCD STEERING SWITCH

[VK45DE]

ABS00CC4

Component Inspection ASCD STEERING SWITCH

1. Disconnect combination switch (spiral cable).
2. Check continuity between combination switch (spiral cable) terminals 14 and 15 with pushing each switch.

Switch	Condition	Resistance [Ω]
ON/OFF (MAIN) switch	Pressed	Approx. 0
	Released	Approx. 4,000
COAST/SET switch	Pressed	Approx. 660
	Released	Approx. 4,000
ACCEL/RESUME switch	Pressed	Approx. 1,480
	Released	Approx. 4,000
CANCEL switch	Pressed	Approx. 250
	Released	Approx. 4,000

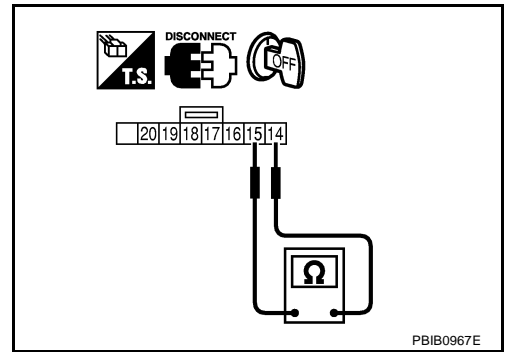

A
EC
C
D
E
F
G
H
I
J
K
L
M

DTC P1568 ICC FUNCTION

PFP:18995

On Board Diagnosis Logic

ABS00CC5

This self-diagnosis has the one trip detection logic.
The MIL will not light up for this diagnosis.

NOTE:

- If DTC P1568 is displayed with DTC U1000, U1001, first perform the trouble diagnosis for DTC U1000, U1001. Refer to [EC-792, "DTC U1000, U1001 CAN COMMUNICATION LINE"](#) .
- If DTC P1568 is displayed with DTC P0605, first perform the trouble diagnosis for DTC P0605. Refer to [EC-1057, "DTC P0605 ECM"](#)

DTC No.	Trouble Diagnosis Name	DTC Detecting Condition	Possible Cause
P1568 1568	ICC function	ECM detects a difference between signals from ICC unit is out of specified range.	<ul style="list-style-type: none"> ● Harness or connectors (The CAN communication line is open or shorted.) ● ICC unit ● ECM

DTC Confirmation Procedure

ABS00CC6

CAUTION:

Always drive vehicle at a safe speed.

NOTE:

If DTC Confirmation Procedure has been previously conducted, always turn ignition switch OFF and wait at least 10 seconds before conducting the next test.

TESTING CONDITION:

Step 4 may be conducted with the drive wheels lifted in the shop or by driving the vehicle. If a road test is expected to be easier, it is unnecessary to lift the vehicle.

WITH CONSULT-II

1. Turn ignition switch ON.
2. Select "DATA MONITOR" mode with CONSULT-II.
3. Press ON/OFF switch on ICC steering switch.
4. Drive the vehicle at more than 40 km/h (25 MPH).
5. Press COAST/SET switch.
6. If DTC is detected, go to [EC-1188, "Diagnostic Procedure"](#) .

DATA MONITOR	
MONITOR	NO DTC
ENG SPEED	XXX rpm

SEF058Y

WITH GST

Follow the procedure "WITH CONSULT-II" above.

Diagnostic Procedure

ABS00CC7

1. REPLACE ICC UNIT

1. Replace ICC unit.
2. Perform [ACS-9, "ACTION TEST"](#) .
3. Check DTC of ICC unit. Refer to [ACS-40, "TROUBLE DIAGNOSIS FOR SELF-DIAGNOSTIC ITEMS"](#) .

>> INSPECTION END

DTC P1572 ICC BRAKE SWITCH

PFP:25320

Component Description

ABS00CC8

When the brake pedal is depressed, ICC brake switch is turned OFF and stop lamp switch is turned ON. ECM detects the state of the brake pedal by this input of two kinds (ON/OFF signal). Refer to [ACS-6, "DESCRIPTION"](#) for the ICC function.

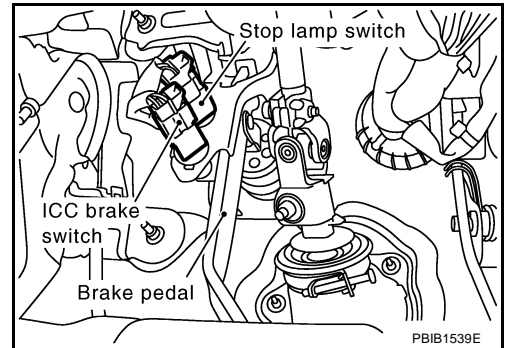

CONSULT-II Reference Value in Data Monitor Mode

ABS00CC9

Specification data are reference values.

MONITOR ITEM	CONDITION		SPECIFICATION
BRAKE SW1 (ICC brake switch)	● Ignition switch: ON	● Brake pedal: Fully released	ON
		● Brake pedal: Slightly depressed	OFF
BRAKE SW2 (stop lamp switch)	● Ignition switch: ON	● Brake pedal: Fully released	OFF
		● Brake pedal: Slightly depressed	ON

On Board Diagnosis Logic

ABS00CCA

**This diagnosis has the one trip detection logic.
The MIL will not light up for this diagnosis.**

NOTE:

- If DTC P1572 is displayed with DTC P0605, first perform the trouble diagnosis for DTC P0605. Refer to [EC-1057](#).
- This self-diagnosis has the one trip detection logic. When malfunction A is detected, DTC is not stored in ECM memory. And in that case, 1st trip DTC and 1st trip freeze frame data are displayed. 1st trip DTC is erased when ignition switch OFF. And even when malfunction A is detected in two consecutive trips, DTC is not stored in ECM memory.

DTC No.	Trouble diagnosis name	DTC detecting condition		Possible cause
P1572 1572	ICC brake switch	A)	● ON signals from the stop lamp switch and the ICC brake switch are sent to ECM at the same time.	<ul style="list-style-type: none"> ● Harness or connectors (The stop lamp switch circuit is open or shorted.) ● Harness or connectors (The ICC brake switch circuit is open or shorted.) ● Stop lamp switch ● ICC brake switch ● ICC brake hold relay ● Incorrect stop lamp switch installation ● Incorrect ICC brake switch installation ● ECM
		B)	● ICC brake switch signal is not sent to ECM for extremely long time while the vehicle is driving.	

DTC Confirmation Procedure

CAUTION:

Always drive vehicle at a safe speed.

NOTE:

- If DTC Confirmation Procedure has been previously conducted, always turn ignition switch OFF and wait at least 10 seconds before conducting the next test.
- Procedure for malfunction B is not described here. It takes extremely long time to complete procedure for malfunction B. By performing procedure for malfunction A, the incident that causes malfunction B can be detected.

TESTING CONDITION:

Steps 3 and 4 may be conducted with the drive wheels lifted in the shop or by driving the vehicle. If a road test is expected to be easier, it is unnecessary to lift the vehicle.

WITH CONSULT-II

1. Start engine (VDC switch OFF).
2. Select "DATA MONITOR" mode with CONSULT-II.
3. Press MAIN switch and make sure that CRUISE indicator lights up.
4. Drive the vehicle for at least 5 consecutive seconds under the following conditions.

VHCL SPEED SE	More than 30 km/h (19 MPH)
Selector lever	Suitable position

If 1st trip DTC is detected, go to [EC-1192, "Diagnostic Procedure"](#) .
 If 1st trip DTC is not detected, go to the following step.

5. Drive the vehicle for at least 5 consecutive seconds under the following conditions.

VHCL SPEED SE	More than 30 km/h (19 MPH)
Selector lever	Suitable position
Driving location	Depress the brake pedal for more than five seconds so as not to come off from the above-mentioned vehicle speed.

6. If 1st trip DTC is detected, go to [EC-1192, "Diagnostic Procedure"](#) .

WITH GST

Follow the procedure "WITH CONSULT-II" above.

DATA MONITOR	
MONITOR	NO DTC
ENG SPEED	XXX rpm
VHCL SPEED SE	XXX km/h
CRUISE LAMP	ON
BRAKE SW 1	ON
BRAKE SW 2	OFF

PBIB2386E

DTC P1572 ICC BRAKE SWITCH

[VK45DE]

Wiring Diagram

ABS00CCC

— : DETECTABLE LINE FOR DTC
 - - - : NON-DETECTABLE LINE FOR DTC

EC-ICC/BS-01

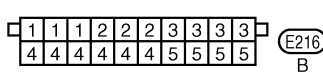
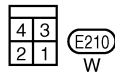
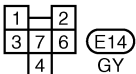
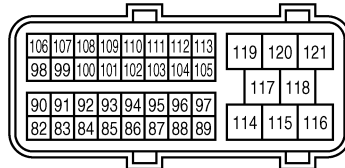
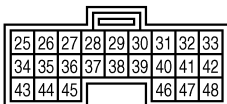
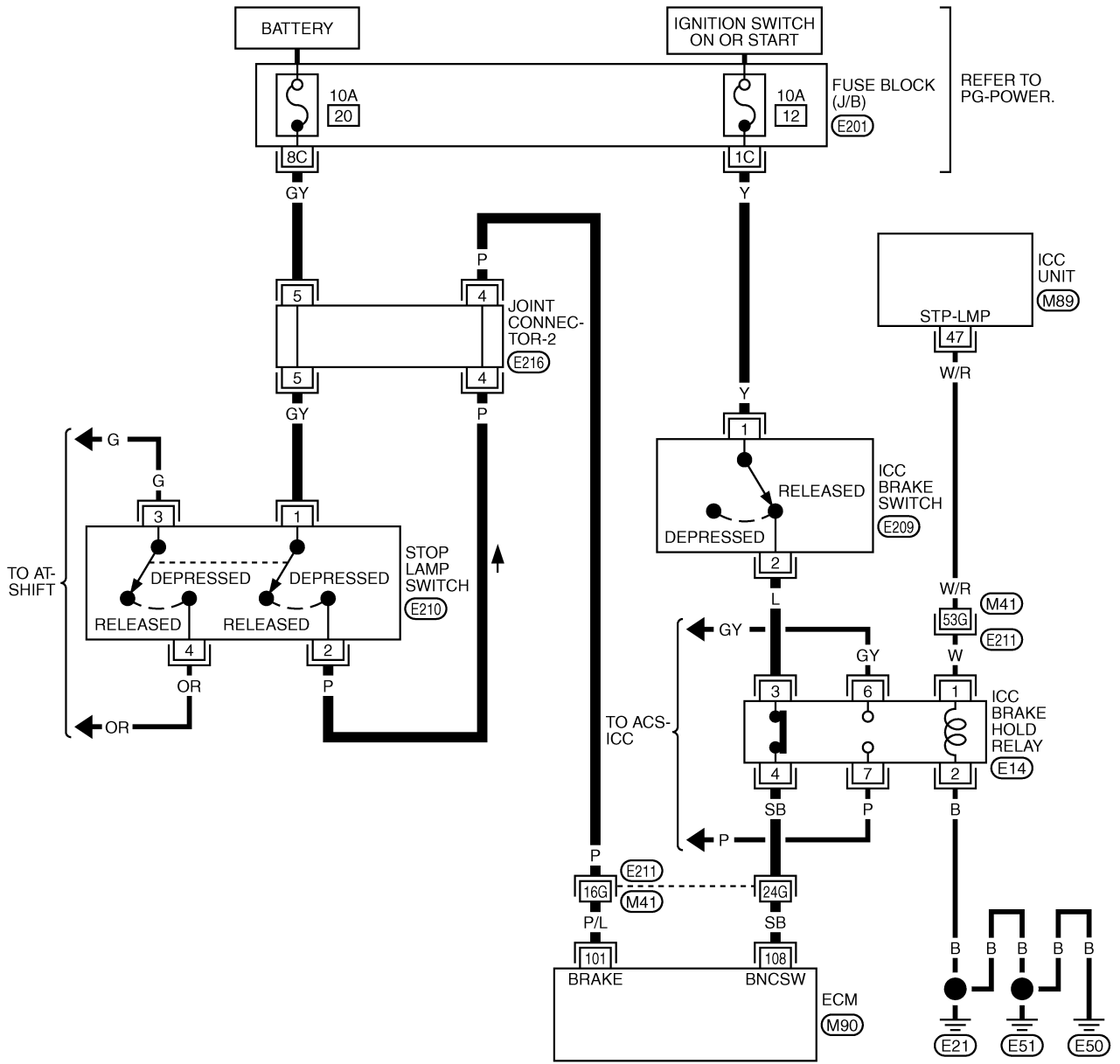

REFER TO THE FOLLOWING.

(E21) -SUPER MULTIPLE JUNCTION (SMJ)

(E20) -FUSE BLOCK-JUNCTION BOX (J/B)

TBWM0274E

DTC P1572 ICC BRAKE SWITCH

[VK45DE]

Specification data are reference values and are measured between each terminal and ground.

CAUTION:

Do not use ECM ground terminals when measuring input/output voltage. Doing so may result in damage to the ECM's transistor. Use a ground other than ECM terminals, such as the ground.

TERMI-NAL NO.	WIRE COLOR	ITEM	CONDITION	DATA (DC Voltage)
101	P/L	Stop lamp switch	[Ignition switch: OFF] ● Brake pedal: Fully released	Approximately 0V
			[Ignition switch: OFF] ● Brake pedal: Slightly depressed	BATTERY VOLTAGE (11 - 14V)
108	SB	ICC brake switch	[Ignition switch: ON] ● Brake pedal: Slightly depressed	Approximately 0V
			[Ignition switch: ON] ● Brake pedal: Fully released	BATTERY VOLTAGE (11 - 14V)

Diagnostic Procedure

ABS00CCD

1. CHECK OVERALL FUNCTION-I

 **With CONSULT-II**

- Turn ignition switch ON.
- Select "BRAKE SW1" in "DATA MONITOR" mode with CONSULT-II.
- Check "BRAKE SW1" indication under the following conditions.

CONDITION	INDICATION
When brake pedal is slightly depressed	OFF
When brake pedal is fully released	ON

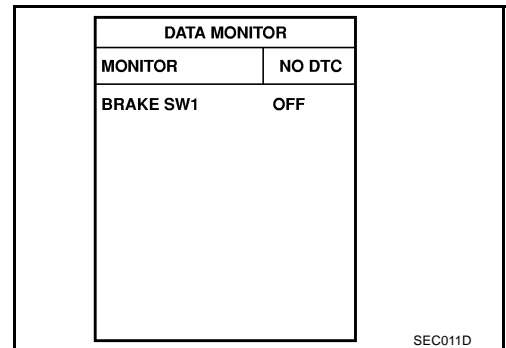

 **Without CONSULT-II**

- Turn ignition switch ON.
- Check voltage between ECM terminal 108 and ground under the following conditions.

CONDITION	VOLTAGE
When brake pedal is slightly depressed	Approximately 0V
When brake pedal is fully released	Battery voltage

OK or NG

- OK >> GO TO 2.
NG >> GO TO 3.

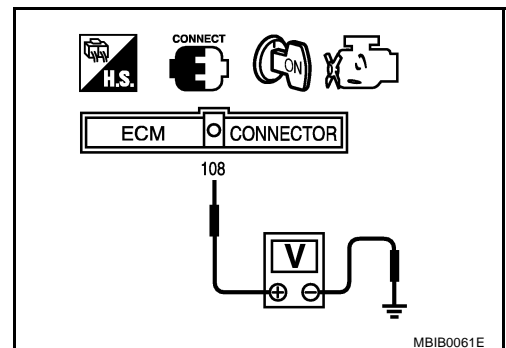

2. CHECK OVERALL FUNCTION-II

 **With CONSULT-II**

Check "BRAKE SW2" indication in "DATA MONITOR" mode.

CONDITION	INDICATION
When brake pedal is fully released	OFF
When brake pedal is slightly depressed	ON

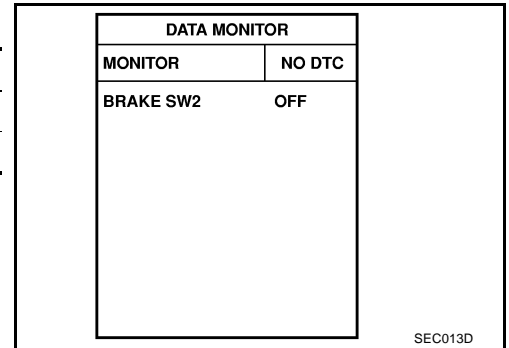

 **Without CONSULT-II**

Check voltage between ECM terminal 101 and ground under the following conditions.

CONDITION	VOLTAGE
When brake pedal is fully released	Approximately 0V
When brake pedal is slightly depressed	Battery voltage

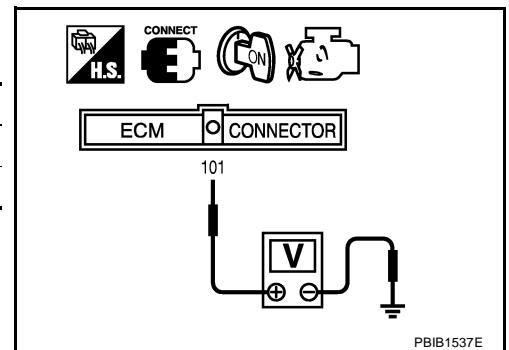

OK or NG

- OK >> GO TO 17.
- NG >> GO TO 12.

3. CHECK DTC WITH ICC UNIT

Refer to [ACS-40, "TROUBLE DIAGNOSIS FOR SELF-DIAGNOSTIC ITEMS"](#) .

OK or NG

- OK >> GO TO 4.
- NG >> Repair or replace.

4. CHECK ICC BRAKE SWITCH CIRCUIT

1. Turn ignition switch OFF.
2. Disconnect ICC brake hold relay.
3. Turn ignition switch ON.

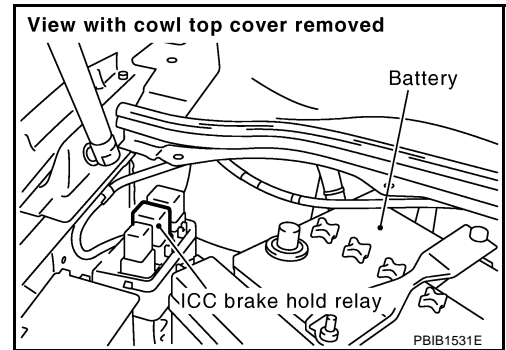

4. Check voltage between ICC brake hold relay terminal 3 and ground with CONSULT-II or tester.

Voltage: Battery voltage

OK or NG

- OK >> GO TO 9.
 NG >> GO TO 5.

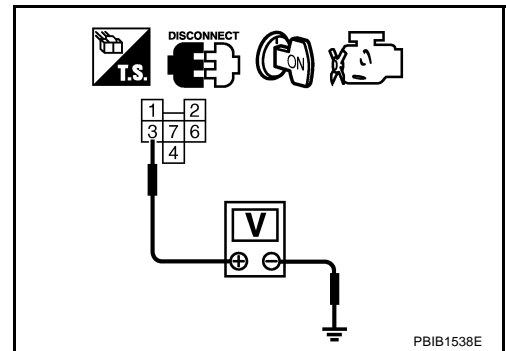

5. CHECK ICC BRAKE SWITCH POWER SUPPLY CIRCUIT

1. Turn ignition switch OFF.
2. Disconnect ICC brake switch harness connector.
3. Turn ignition switch ON.

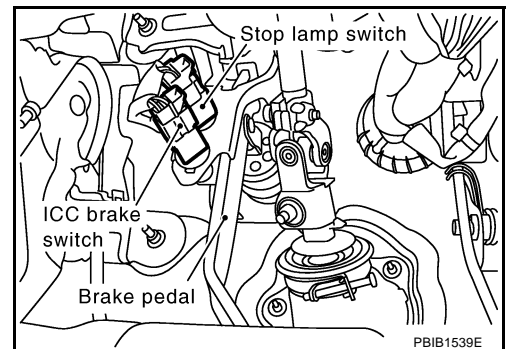

4. Check voltage between ICC brake switch terminal 1 and ground with CONSULT-II or tester.

Voltage: Battery voltage

OK or NG

- OK >> GO TO 7.
 NG >> GO TO 6.

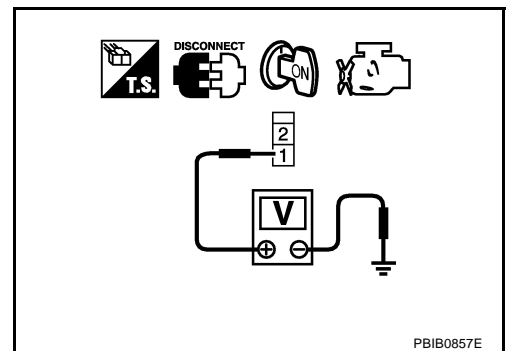

6. DETECT MALFUNCTIONING PART

Check the following.

- Fuse block (J/B) connector E201
- 10A fuse
- Harness for open or short between ICC brake switch and fuse

>> Repair open circuit or short to ground or short to power in harness or connectors.

7. CHECK ICC BRAKE SWITCH INPUT SIGNAL CIRCUIT FOR OPEN AND SHORT-I

1. Turn ignition switch OFF.
2. Check harness continuity between ICC brake hold relay terminal 3 and ICC brake switch terminal 2.
Refer to Wiring Diagram.

Continuity should exist.

3. Also check harness for short to ground and short to power.

OK or NG

OK >> GO TO 8.

NG >> Repair open circuit or short to ground or short to power in harness or connectors.

8. CHECK ICC BRAKE SWITCH

Refer to [EC-1197, "Component Inspection"](#).

OK or NG

OK >> GO TO 17.

NG >> Replace ICC brake switch.

9. CHECK ICC BRAKE SWITCH INPUT SIGNAL CIRCUIT FOR OPEN AND SHORT-II

1. Turn ignition switch OFF.
2. Disconnect ECM harness connector.
3. Check harness continuity between ICC brake hold relay terminal 4 and ECM terminal 108.
Refer Wiring Diagram.

Continuity should exist.

4. Also check harness for short to ground and short to power.

OK or NG

OK >> GO TO 11.

NG >> GO TO 10.

10. DETECT MALFUNCTIONING PART

Check the following.

- Harness connectors E211, M41
- Harness for open or short between ICC brake hold relay and ECM

>> Repair open circuit or short to ground or short to power in harness or connectors.

11. CHECK ICC BRAKE HOLD RELAY

Refer to [EC-1197, "Component Inspection"](#).

OK >> GO TO 17.

NG >> Replace ICC brake hold relay.

12. CHECK STOP LAMP SWITCH POWER SUPPLY CIRCUIT

1. Turn ignition switch OFF.
2. Disconnect stop lamp switch harness connector.

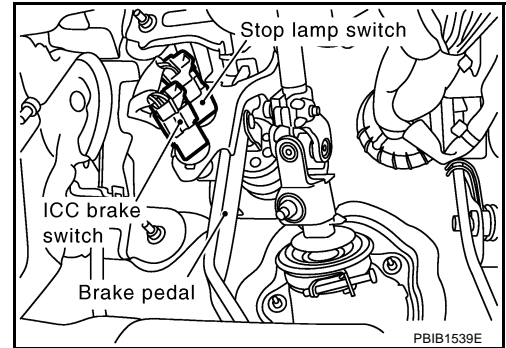

3. Check voltage between stop lamp switch terminal 1 and ground with CONSULT -II or tester.

Voltage: Battery voltage

OK or NG

- OK >> GO TO 14.
NG >> GO TO 13.

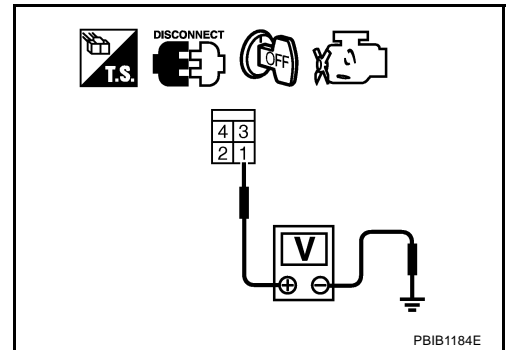

13. DETECT MALFUNCTIONING PART

Check the following.

- Fuse block (J/B) connector E201
- 10A fuse
- Joint connector-2
- Harness for open or short between stop lamp switch and battery

>> Repair open circuit or short to ground or short to power in harness or connectors.

14. CHECK STOP LAMP SWITCH INPUT SIGNAL CIRCUIT FOR OPEN AND SHORT

1. Disconnect ECM harness connector.
2. Check harness continuity between ECM terminal 101 and stop lamp switch terminal 2. Refer to Wiring Diagram.

Continuity should exist.

3. Also check harness for short to ground and short to power.

OK or NG

- OK >> GO TO 16.
NG >> GO TO 15.

15. DETECT MALFUNCTIONING PART

Check the following.

- Harness connectors E211, M41
- Joint connector-2
- Harness for open or short between ECM and stop lamp switch

>> Repair open circuit or short to ground or short to power in harness or connectors.

16. CHECK STOP LAMP SWITCH

Refer to [EC-1197, "Component Inspection"](#)

OK or NG

- OK >> GO TO 17.
- NG >> Replace stop lamp switch.

17. CHECK INTERMITTENT INCIDENT

Refer to [EC-784, "TROUBLE DIAGNOSIS FOR INTERMITTENT INCIDENT"](#) .

>> INSPECTION END

Component Inspection ICC BRAKE SWITCH

ABS00CCE

1. Turn ignition switch OFF.
2. Disconnect ICC brake switch harness connector.
3. Check continuity between ICC brake switch terminals 1 and 2 under the following conditions.

Condition	Continuity
When brake pedal is fully released.	Should exist.
When brake pedal is depressed.	Should not exist.

If NG, adjust ICC brake switch installation, refer to [BR-6, "BRAKE PEDAL"](#) , and perform step 3 again.

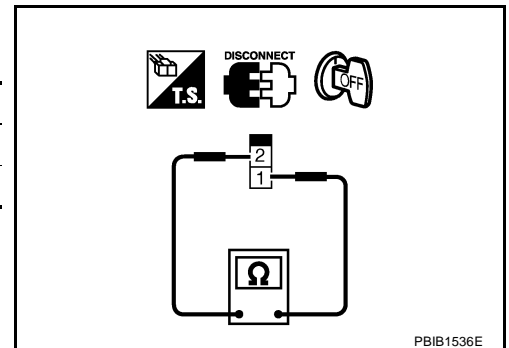

STOP LAMP SWITCH

1. Turn ignition switch OFF.
2. Disconnect stop lamp switch harness connector.
3. Check continuity between stop lamp switch terminals 1 and 2 under the following conditions.

Condition	Continuity
When brake pedal is fully released.	Should not exist.
When brake pedal is depressed.	Should exist.

If NG, adjust stop lamp switch installation, refer to [BR-6, "BRAKE PEDAL"](#) , and perform step 3 again.

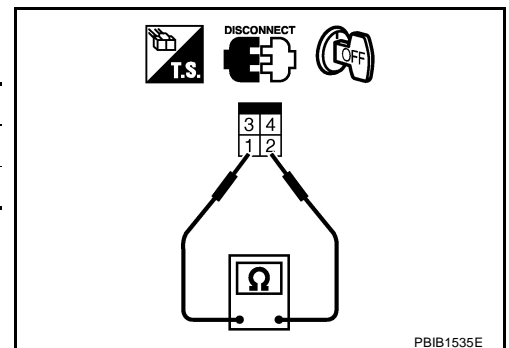

ICC BRAKE HOLD RELAY

1. Apply 12V direct current between ICC brake hold relay terminals 1 and 2.

DTC P1572 ICC BRAKE SWITCH

[VK45DE]

2. Check continuity between relay terminals 3 and 4, 6 and 7 under the following conditions.

Condition	Between terminals	Continuity
12V direct current supply between terminals 1 and 2	3 and 4	Should not exist
	6 and 7	Should exist
No current supply	3 and 4	Should exist
	6 and 7	Should not exist

3. If NG, replace ICC brake hold relay.

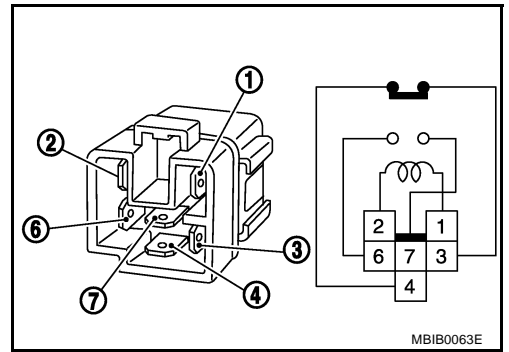

DTC P1572 ASCD BRAKE SWITCH

PFP:25320

Component Description

ABS00CCF

When the brake pedal is depressed, ASCD brake switch is turned OFF and stop lamp switch is turned ON. ECM detects the state of the brake pedal by this input of two kinds (ON/OFF signal).

Refer to [EC-1334](#), "AUTOMATIC SPEED CONTROL DEVICE (ASCD)" for the ASCD function.

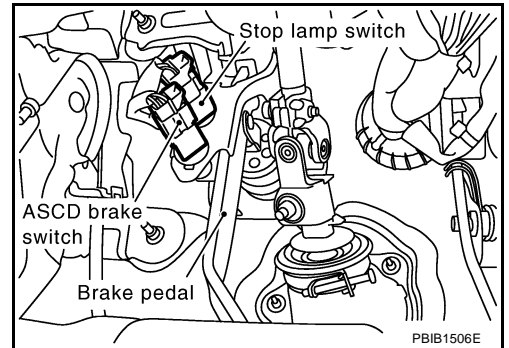

CONSULT-II Reference Value in Data Monitor Mode

ABS00CCG

Specification data are reference values.

MONITOR ITEM	CONDITION		SPECIFICATION
BRAKE SW 1 (ASCD brake switch)	● Ignition switch: ON	● Brake pedal: Fully released	ON
		● Brake pedal: Slightly depressed	OFF
BRAKE SW 2 (stop lamp switch)	● Ignition switch: ON	● Brake pedal: Fully released	OFF
		● Brake pedal: Slightly depressed	ON

On Board Diagnosis Logic

ABS00CCH

This self-diagnosis has the one trip detection logic.

The MIL will not light up for this diagnosis.

NOTE:

- If DTC P 1572 is displayed with DTC P0605, first perform the trouble diagnosis for DTC P0605. Refer to [EC-1057](#).
- This self-diagnosis has the one trip detection logic. When malfunction A is detected, DTC is not stored in ECM memory. And in that case, 1st trip DTC and 1st trip freeze frame data are displayed. 1st trip DTC is erased when ignition switch OFF. And even when malfunction A is detected in two consecutive trips, DTC is not stored in ECM memory.

DTC No.	Trouble diagnosis name	DTC detecting condition		Possible cause
P1572 1572	ASCD brake switch	A)	● When the vehicle speed is above 30 km/h (19 MPH), ON signals from the stop lamp switch and the ASCD brake switch are sent to the ECM at the same time.	<ul style="list-style-type: none"> ● Harness or connectors (The stop lamp switch circuit is open or shorted.) ● Harness or connectors (The ASCD brake switch circuit is open or shorted.) ● Stop lamp switch ● ASCD brake switch ● Incorrect stop lamp switch installation ● Incorrect ASCD brake switch installation ● ECM
		B)	● ASCD brake switch signal is not sent to ECM for extremely long time while the vehicle is driving.	

DTC Confirmation Procedure

CAUTION:

Always drive vehicle at a safe speed.

NOTE:

- If DTC Confirmation Procedure has been previously conducted, always turn ignition switch OFF and wait at least 10 seconds before conducting the next test.
- Procedure for malfunction B is not described here. It takes extremely long time to complete procedure for malfunction B. By performing procedure for malfunction A, the incident that causes malfunction B can be detected.

TESTING CONDITION:

Steps 3 and 4 may be conducted with the drive wheels lifted in the shop or by driving the vehicle. If a road test is expected to be easier, it is unnecessary to lift the vehicle.

WITH CONSULT-II

1. Start engine (VDC switch OFF).
2. Select "DATA MONITOR" mode with CONSULT-II.
3. Press MAIN switch and make sure that CRUISE indicator lights up.
4. Drive the vehicle for at least 5 consecutive seconds under the following conditions.

VHCL SPEED SE	More than 30 km/h (19 MPH)
Selector lever	Suitable position

If 1st trip DTC is detected, go to [EC-1202, "Diagnostic Procedure"](#) .
 If 1st trip DTC is not detected, go to the following step.

5. Drive the vehicle for at least 5 consecutive seconds under the following conditions.

VHCL SPEED SE	More than 30 km/h (19 MPH)
Selector lever	Suitable position
Driving location	Depress the brake pedal for more than five seconds so as not to come off from the above-mentioned vehicle speed.

6. If 1st trip DTC is detected, go to [EC-1202, "Diagnostic Procedure"](#) .

WITH GST

Follow the procedure "WITH CONSULT-II" above.

DATA MONITOR	
MONITOR	NO DTC
ENG SPEED	XXX rpm
VHCL SPEED SE	XXX km/h
CRUISE LAMP	ON
BRAKE SW 1	ON
BRAKE SW 2	OFF

PBIB2386E

DTC P1572 ASCD BRAKE SWITCH

[VK45DE]

Wiring Diagram

ABS00CCJ

EC-ASC/BS-01

— : DETECTABLE LINE FOR DTC
 — : NON-DETECTABLE LINE FOR DTC

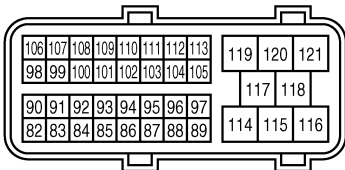
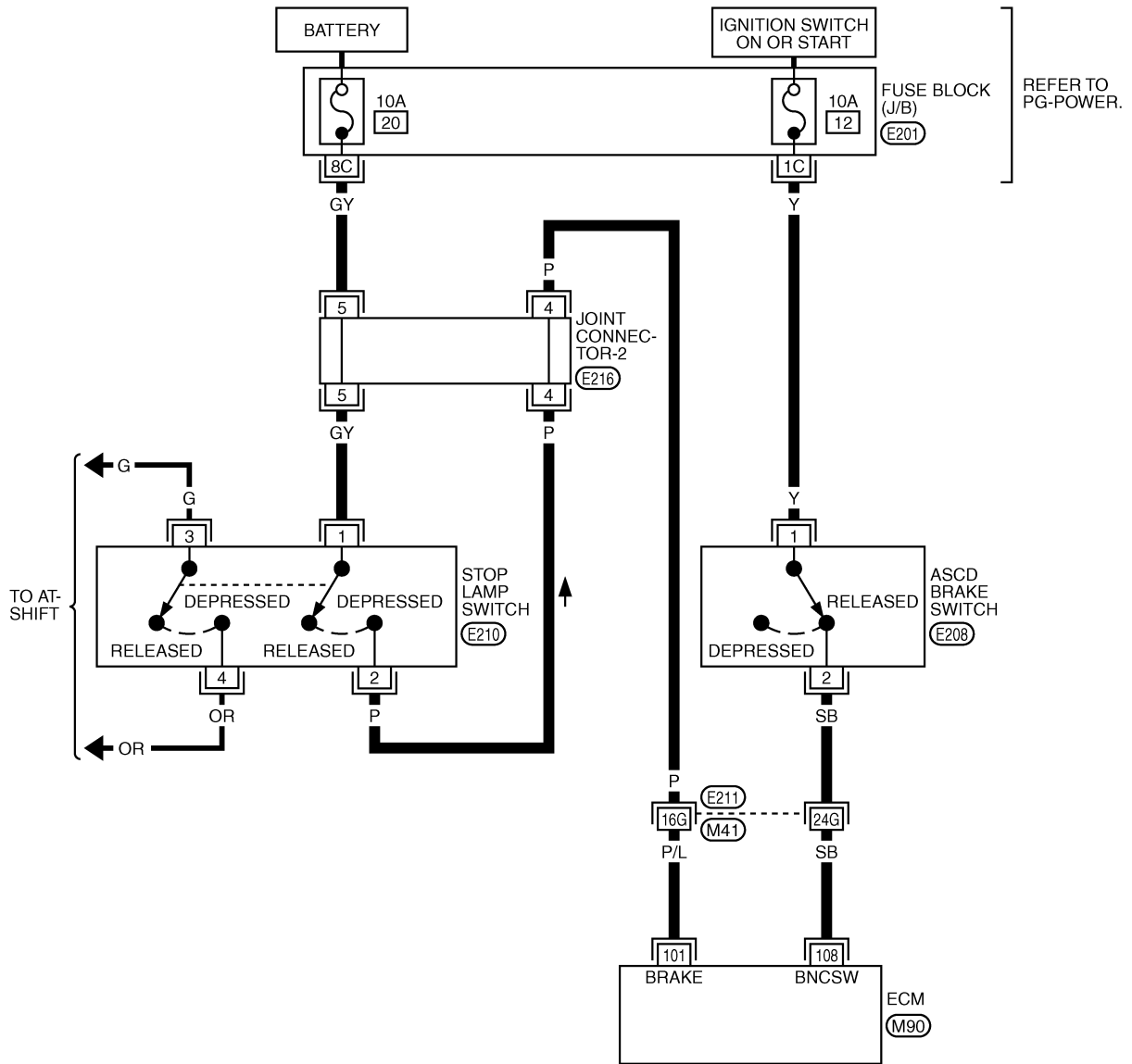

(M90) B



(E208) BR

(E210) W

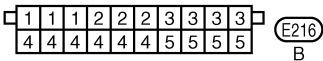

(E216) B

REFER TO THE FOLLOWING.

(E211) -SUPER MULTIPLE JUNCTION (SMJ)

(E201) -FUSE BLOCK-JUNCTION BOX (J/B)

TBWM0258E

DTC P1572 ASCD BRAKE SWITCH

[VK45DE]

Specification data are reference values and are measured between each terminal and ground.

CAUTION:

Do not use ECM ground terminals when measuring input/output voltage. Doing so may result in damage to the ECM's transistor. Use a ground other than ECM terminals, such as the ground.

TER-MINAL NO.	WIRE COLOR	ITEM	CONDITION	DATA (DC Voltage)
101	P/L	Stop lamp switch	[Ignition switch: OFF] ● Brake pedal: Fully released	Approximately 0V
			[Ignition switch: OFF] ● Brake pedal: Slightly depressed	BATTERY VOLTAGE (11 - 14V)
108	SB	ASCD brake switch	[Ignition switch: ON] ● Brake pedal: Slightly depressed	Approximately 0V
			[Ignition switch: ON] ● Brake pedal: Fully released	BATTERY VOLTAGE (11 - 14V)

Diagnostic Procedure

ABS00CCK

1. CHECK OVERALL FUNCTION-I

 **With CONSULT-II**

- Turn ignition switch ON.
- Select "BRAKE SW1" in "DATA MONITOR" mode with CONSULT-II.
- Check "BRAKE SW1" indication under the following conditions.

CONDITION	INDICATION
When brake pedal is slightly depressed	OFF
When brake pedal is fully released	ON

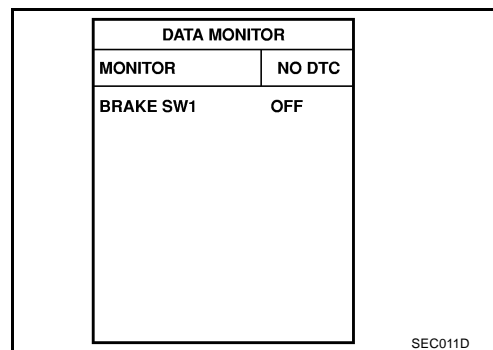

 **Without CONSULT-II**

- Turn ignition switch ON.
- Check voltage between ECM terminal 108 and ground under the following conditions.

CONDITION	VOLTAGE
When brake pedal is slightly depressed	Approximately 0V
When brake pedal is fully released	Battery voltage

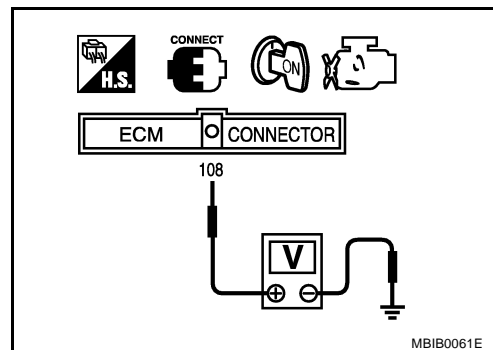

OK or NG

- OK >> GO TO 2.
NG >> GO TO 3.

DTC P1572 ASCD BRAKE SWITCH

[VK45DE]

2. CHECK OVERALL FUNCTION-II

With CONSULT-II

Check "BRAKE SW2" indication in "DATA MONITOR" mode.

CONDITION	INDICATION
When brake pedal is fully released	OFF
When brake pedal is slightly depressed	ON

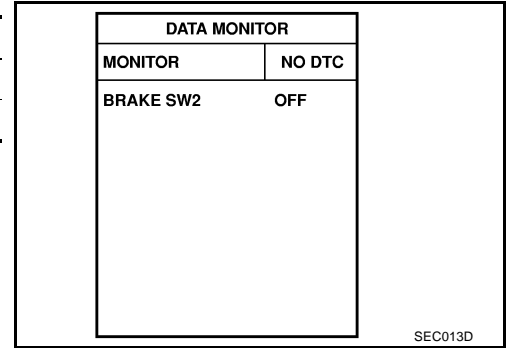

Without CONSULT-II

Check voltage between ECM terminal 101 and ground under the following conditions.

CONDITION	VOLTAGE
When brake pedal is fully released	Approximately 0V
When brake pedal is slightly depressed	Battery voltage

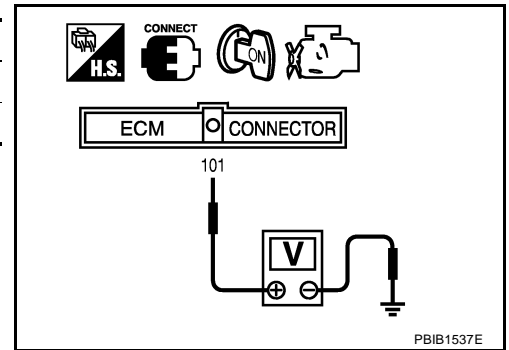

OK or NG

- OK >> GO TO 13.
- NG >> GO TO 8.

A
EC
C
D
E
F
G
H
I
J
K
L
M

3. CHECK ASCD BRAKE SWITCH POWER SUPPLY CIRCUIT

1. Turn ignition switch OFF.
2. Disconnect ASCD brake switch harness connector.
3. Turn ignition switch ON.

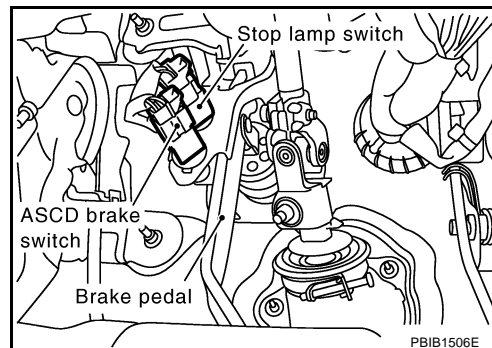

4. Check voltage between ASCD brake switch terminal 1 and ground with CONSULT-II or tester.

Voltage: Battery voltage

OK or NG

- OK >> GO TO 5.
- NG >> GO TO 4.

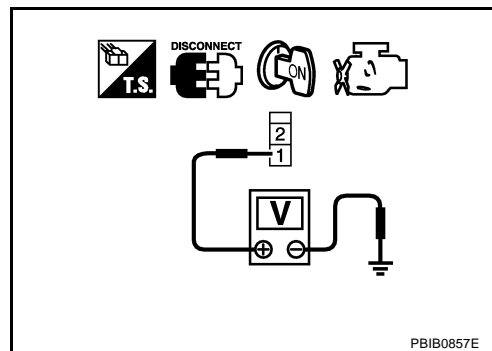

4. DETECT MALFUNCTIONING PART

Check the following.

- Fuse block (J/B) connector E201
- 10A fuse
- Harness for open or short between ASCD brake switch and fuse

>> Repair open circuit or short to ground or short to power in harness or connectors.

5. CHECK ASCD BRAKE SWITCH INPUT SIGNAL CIRCUIT FOR OPEN AND SHORT

1. Turn ignition switch OFF.
2. Disconnect ECM harness connector.
3. Check harness continuity between ECM terminal 108 and ASCD brake switch terminal 2. Refer to Wiring Diagram.

Continuity should exist.

4. Also check harness for short to ground and short to power.

OK or NG

- OK >> GO TO 7.
- NG >> GO TO 6.

6. DETECT MALFUNCTIONING PART

Check the following.

- Harness connectors E211, M41
- Harness for open or short between ECM and ASCD brake switch

>> Repair open circuit or short to ground or short to power in harness or connectors.

7. CHECK ASCD BRAKE SWITCH

Refer to [EC-1206, "Component Inspection"](#)

OK or NG

- OK >> GO TO 13.
- NG >> Replace ASCD brake switch.

8. CHECK STOP LAMP SWITCH POWER SUPPLY CIRCUIT

1. Turn ignition switch OFF.
2. Disconnect stop lamp switch harness connector.

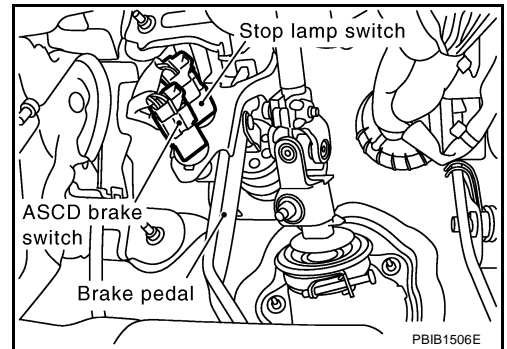

3. Check voltage between stop lamp switch terminal 1 and ground with CONSULT-II or tester.

Voltage: Battery voltage

OK or NG

- OK >> GO TO 10.
- NG >> GO TO 9.

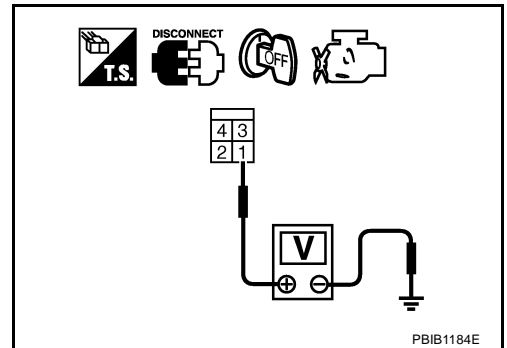

9. DETECT MALFUNCTIONING PART

Check the following.

- Fuse block (J/B) connector E201
- 10A fuse
- Joint connector-2
- Harness for open or short between stop lamp switch and battery

>> Repair open circuit or short to ground or short to power in harness or connectors.

10. CHECK STOP LAMP SWITCH INPUT SIGNAL CIRCUIT FOR OPEN AND SHORT

1. Disconnect ECM harness connector.
2. Check harness continuity between ECM terminal 101 and stop lamp switch terminal 2. Refer to Wiring Diagram.

Continuity should exist.

3. Also check harness for short to ground and short to power.

OK or NG

- OK >> GO TO 12.
- NG >> GO TO 11.

11. DETECT MALFUNCTIONING PART

Check the following.

- Harness connectors E211, M41
- Joint connector-2
- Harness for open or short between ECM and stop lamp switch

>> Repair open circuit or short to ground or short to power in harness or connectors.

12. CHECK STOP LAMP SWITCH

Refer to [EC-1206, "Component Inspection"](#)

OK or NG

- OK >> GO TO 13.
- NG >> Replace stop lamp switch.

13. CHECK INTERMITTENT INCIDENT

Refer to [EC-784, "TROUBLE DIAGNOSIS FOR INTERMITTENT INCIDENT"](#) .

>> **INSPECTION END**

Component Inspection ASC D BRAKE SWITCH

ABS00CCL

1. Turn ignition switch OFF.
2. Disconnect ASCD brake switch harness connector.
3. Check harness continuity between ASCD brake switch terminals 1 and 2 under the following conditions.

Condition	Continuity
When brake pedal is fully released.	Should exist.
When brake pedal is slightly depressed.	Should not exist.

If NG, adjust ASCD brake switch installation, refer to [BR-6, "BRAKE PEDAL"](#) , and perform step 3 again.

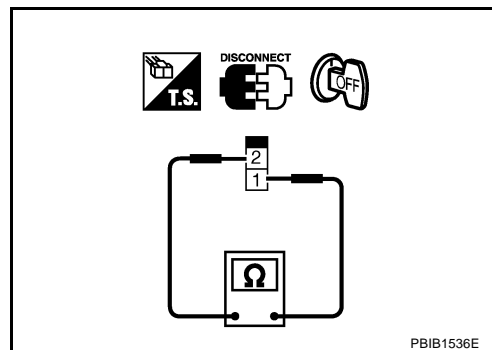

STOP LAMP SWITCH

1. Turn ignition switch OFF.
2. Disconnect stop lamp switch harness connector.
3. Check harness continuity between stop lamp switch terminals 1 and 2 under the following conditions.

Condition	Continuity
When brake pedal is fully released.	Should not exist.
When brake pedal is slightly depressed.	Should exist.

If NG, adjust stop lamp switch installation, refer to [BR-6, "BRAKE PEDAL"](#) , and perform step 3 again.

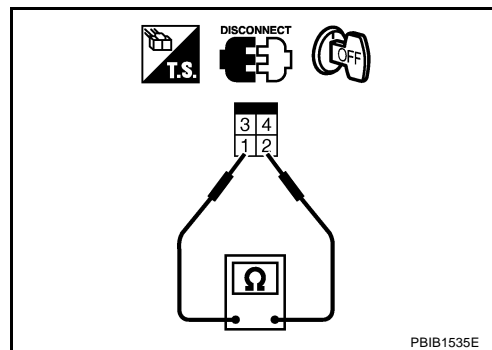

DTC P1574 ICC VEHICLE SPEED SENSOR

PFP:31036

Component Description

ABS00CCM

The ECM receives two vehicle speed signals via CAN communication line. One is sent from “unified meter and A/C amp.”, and the other is from TCM (Transmission control module). The ECM uses these signals for ICC control. Refer to [ACS-6, "DESCRIPTION"](#) for ICC functions.

On Board Diagnosis Logic

ABS00CCN

**This self-diagnosis has the one trip detection logic.
The MIL will not light up for this diagnosis.**

NOTE:

- If DTC P1574 is displayed with DTC U1000, U1001, first perform the trouble diagnosis for DTC U1000, U1001. Refer to [EC-792, "DTC U1000, U1001 CAN COMMUNICATION LINE"](#) .
- If DTC P1574 is displayed with DTC P0500, first perform the trouble diagnosis for DTC P0500. Refer to [EC-1046, "DTC P0500 VSS"](#) .

DTC No.	Trouble diagnosis name	DTC detecting condition	Possible cause
P1574 1574	ICC vehicle speed sensor	ECM detects a difference between two vehicle speed signals is out of the specified range.	<ul style="list-style-type: none"> ● Harness or connectors (The CAN communication line is open or shorted.) ● TCM ● ABS actuator and electric unit (control unit) ● Wheel sensor ● Unified meter and A/C amp. ● ECM

DTC Confirmation Procedure

ABS00CCO

CAUTION:

Always drive vehicle at a safe speed.

NOTE:

If DTC Confirmation Procedure has been previously conducted, always turn ignition switch OFF and wait at least 10 seconds before conducting the next test.

TESTING CONDITION:

Step 3 may be conducted with the drive wheels lifted in the shop or by driving the vehicle. If a road test is expected to be easier, it is unnecessary to lift the vehicle.

WITH CONSULT-II

1. Start engine (VDC switch OFF).
2. Select “DATA MONITOR” mode with CONSULT-II.
3. Drive the vehicle at more than 40 km/h (25MPH).
4. If DTC is detected, go to [EC-1208, "Diagnostic Procedure"](#) .

DATA MONITOR	
MONITOR	NO DTC
ENG SPEED	XXX rpm

SEF058Y

WITH GST

Follow the procedure “WITH CONSULT-II” above.

Diagnostic Procedure

ABS00CCP

1. CHECK DTC WITH TCM

Check DTC with TCM. Refer to [AT-38, "ON BOARD DIAGNOSTIC \(OBD\) SYSTEM"](#) .

OK or NG

OK >> GO TO 2.

NG >> Perform trouble shooting relevant to DTC indicated.

2. CHECK DTC WITH "ABS ACTUATOR AND ELECTRIC UNIT (CONTROL UNIT)"

Refer to [BRC-12, "TROUBLE DIAGNOSIS"](#) .

OK or NG

OK >> GO TO 3.

NG >> Repair or replace.

3. CHECK DTC WITH "UNIFIED METER AND A/C AMP."

Check combination meter function.

Refer to [DI-28, "UNIFIED METER AND A/C AMP"](#) .

>> **INSPECTION END**

DTC P1574 ASCD VEHICLE SPEED SENSOR

PFP:31036

Component Description

ABS00CCQ

The ECM receives two vehicle speed sensor signals via CAN communication line. One is sent from “unified meter and A/C amp.”, and the other is from TCM (Transmission control module). The ECM uses these signals for ASCD control. Refer to [EC-1334, "AUTOMATIC SPEED CONTROL DEVICE \(ASCD\)"](#) for ASCD functions.

On Board Diagnosis Logic

ABS00CCR

**This self-diagnosis has the one trip detection logic.
The MIL will not light up for this diagnosis.**

NOTE:

- If DTC P1574 is displayed with DTC U1000, U1001, first perform the trouble diagnosis for DTC U1000, U1001. Refer to [EC-792, "DTC U1000, U1001 CAN COMMUNICATION LINE"](#) .
- If DTC P1574 is displayed with DTC P0500, first perform the trouble diagnosis for DTC P0500. Refer to [EC-1046, "DTC P0500 VSS"](#)
- If DTC P1574 is displayed with DTC P0605, first perform the trouble diagnosis for DTC P0605. Refer to [EC-1057, "DTC P0605 ECM"](#)

DTC No.	Trouble diagnosis name	DTC detecting condition	Possible cause
P1574 1574	ASCD vehicle speed sensor	ECM detects a difference between two vehicle speed signals is out of the specified range.	<ul style="list-style-type: none"> ● Harness or connectors (The CAN communication line is open or shorted.) ● Unified meter and A/C amp. ● ABS actuator and electric unit (control unit) ● Wheel sensor ● TCM ● ECM

DTC Confirmation Procedure

ABS00CCS

CAUTION:

Always drive vehicle at a safe speed.

NOTE:

If DTC Confirmation Procedure has been previously conducted, always turn ignition switch OFF and wait at least 10 seconds before conducting the next test.

TESTING CONDITION:

Step 3 may be conducted with the drive wheels lifted in the shop or by driving the vehicle. If a road test is expected to be easier, it is unnecessary to lift the vehicle.

Ⓟ WITH CONSULT-II

1. Start engine (VDC switch OFF).
2. Select “DATA MONITOR” mode with CONSULT-II.
3. Drive the vehicle at more than 40 km/h (25 MPH).
4. If DTC is detected, go to [EC-1210, "Diagnostic Procedure"](#) .

DATA MONITOR	
MONITOR	NO DTC
ENG SPEED	XXX rpm

SEF058Y

Ⓢ WITH GST

Follow the procedure “WITH CONSULT-II” above.

Diagnostic Procedure

ABS00CCT

1. CHECK DTC WITH TCM

Check DTC with TCM. Refer to [AT-38](#).

OK or NG

OK >> GO TO 2.

NG >> Perform trouble shooting relevant to DTC indicated.

2. CHECK DTC WITH “ABS ACTUATOR AND ELECTRIC UNIT (CONTROL UNIT)”

Refer to [BRC-12, "TROUBLE DIAGNOSIS"](#).

OK or NG

OK >> GO TO 3.

NG >> Repair or replace.

3. CHECK DTC WITH “UNIFIED METER AND A/C AMP.”

Refer to [DI-28, "UNIFIED METER AND A/C AMP"](#).

>> **INSPECTION END**

DTC P1706 PNP SWITCH

[VK45DE]

DTC P1706 PNP SWITCH

PFP:32006

Component Description

ABS00CCU

When the gear position is P or N, park/neutral position (PNP) switch is ON. ECM detects the position because the continuity of the line (the ON signal) exists.

CONSULT-II Reference Value in Data Monitor Mode

ABS00CCV

Specification data are reference values.

MONITOR ITEM	CONDITION		SPECIFICATION
P/N POSI SW	● Ignition switch: ON	Shift lever: P or N	ON
		Shift lever: Except above	OFF

On Board Diagnosis Logic

ABS00CCW

DTC No.	Trouble diagnosis name	DTC detecting condition	Possible cause
P1706 1706	Park/neutral position switch	The signal of the park/neutral position (PNP) switch is not changed in the process of engine starting and driving.	<ul style="list-style-type: none"> ● Harness or connectors [The park/neutral position (PNP) switch circuit is open or shorted.] ● Park/neutral position (PNP) switch ● Unified meter and A/C amp. ● TCM

DTC Confirmation Procedure

ABS00CCX

CAUTION:

Always drive vehicle at a safe speed.

NOTE:

If DTC Confirmation Procedure has been previously conducted, always turn ignition switch OFF and wait at least 10 seconds before conducting the next test.

WITH CONSULT-II

1. Turn ignition switch ON.
2. Select "P/N POSI SW" in "DATA MONITOR" mode with CONSULT-II. Then check the "P/N POSI SW" signal under the following conditions.

Position (Selector lever)	Known-good signal
N or P position	ON
Except above position	OFF

If NG, go to [EC-1214, "Diagnostic Procedure"](#).
If OK, go to following step.

3. Select "DATA MONITOR" mode with CONSULT-II.
4. Start engine and warm it up to normal operating temperature.
5. Maintain the following conditions for at least 60 consecutive seconds.

ENG SPEED	1,200 - 6375 rpm
COOLAN TEMP/S	More than 70°C (158°F)
B/FUEL SCHDL	More than 2.0 msec
VHCL SPEED SE	More than 64 km/h (40 MPH)
Selector lever	Suitable position

6. If 1st trip DTC is detected, go to [EC-1214, "Diagnostic Procedure"](#).

DATA MONITOR	
MONITOR	NO DTC
P/N POSI SW	ON

SEF212Y

DATA MONITOR	
MONITOR	NO DTC
ENG SPEED	XXX rpm
COOLAN TEMP/S	XXX °C
VHCL SPEED SE	XXX km/h
P/N POSI SW	OFF
B/FUEL SCHDL	XXX msec

SEF213Y

Overall Function Check

Use this procedure to check the overall function of the park/neutral position (PNP) switch circuit. During this check, a 1st trip DTC might not be confirmed.

Ⓒ WITH GST

1. Turn ignition switch ON.
2. Check voltage between ECM terminal 102 (PNP switch signal) and ground under the following conditions.

Condition (Gear position)	Voltage V (Known good data)
P or N position	Approx. 0
Except above position	BATTERY VOLTAGE (11 - 14V)

3. If NG, go to [EC-1214, "Diagnostic Procedure"](#).

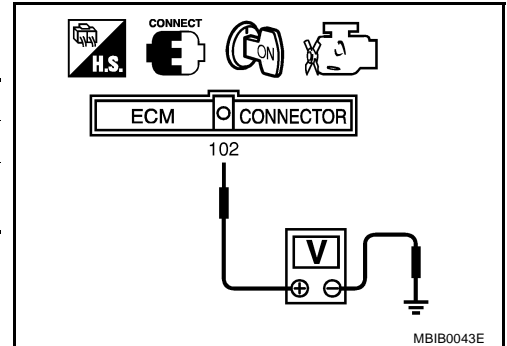

DTC P1706 PNP SWITCH

[VK45DE]

ABS00CGZ

Wiring Diagram

EC-PNP/SW-01

A
EC
C
D
E
F
G
H
I
J
K
L
M

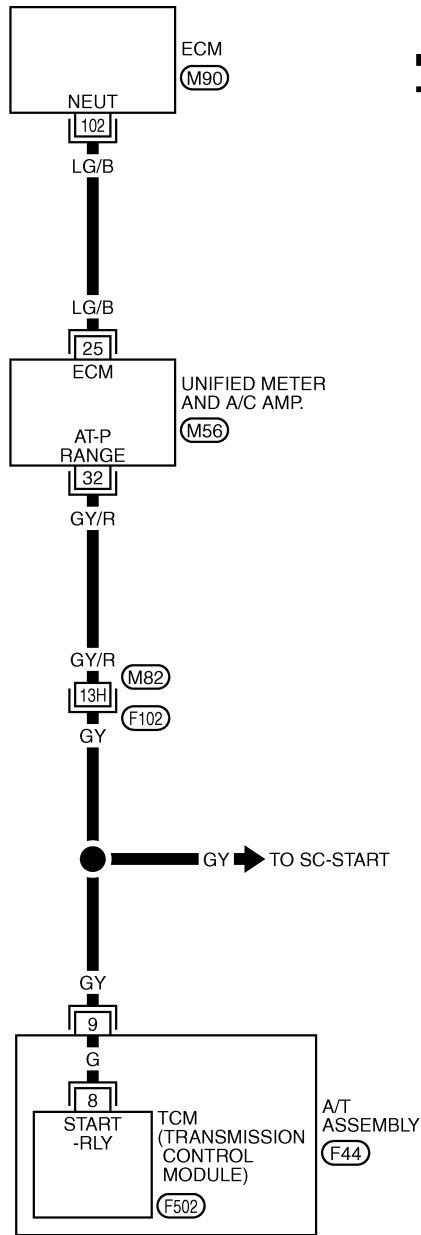

— : DETECTABLE LINE FOR DTC
 — : NON-DETECTABLE LINE FOR DTC

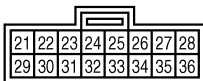

M56
GY

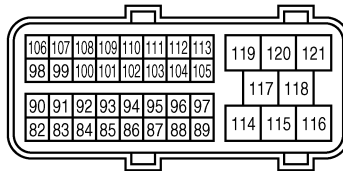

M90
B

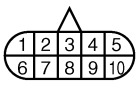

F44
DGY

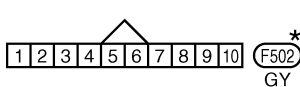

F502
GY

*: THIS CONNECTOR IS NOT SHOWN IN "HARNESS LAYOUT", PG SECTION.

REFER TO THE FOLLOWING.

F102 -SUPER MULTIPLE JUNCTION (SMJ)

TBWM0521E

DTC P1706 PNP SWITCH

[VK45DE]

Specification data are reference values and are measured between each terminal and ground.

CAUTION:

Do not use ECM ground terminals when measuring input/output voltage. Doing so may result in damage to the ECM's transistor. Use a ground other than ECM terminals, such as the ground.

TER-MINAL NO.	WIRE COLOR	ITEM	CONDITION	DATA (DC Voltage)
102	LG/B	PNP switch	[Ignition switch: ON] ● Shift lever: P or N	Approximately 0V
			[Ignition switch: ON] ● Except above position	BATTERY VOLTAGE (11 - 14V)

Diagnostic Procedure

ABS00C00

1. CHECK DTC WITH TCM

Refer to [AT-38, "OBD-II Diagnostic Trouble Code \(DTC\)"](#).

OK or NG

- OK >> GO TO 2.
- NG >> Repair or replace.

2. CHECK STARTING SYSTEM

Turn ignition switch OFF, then turn it to START.

Does starter motor operate?

Yes or No

- Yes >> GO TO 3.
- No >> Refer to [SC-10, "STARTING SYSTEM"](#).

3. CHECK PNP SWITCH INPUT SIGNAL CIRCUIT FOR OPEN AND SHORT-I

1. Turn ignition switch OFF.
2. Disconnect A/T assembly harness connector.
3. Disconnect "unified meter and A/C amp." harness connector.
4. Check harness continuity between A/T assembly terminal 9 and "unified meter and A/C amp." terminal 32. Refer to Wiring Diagram.

Continuity should exist.

5. Also check harness for short to ground and short to power.

OK or NG

- OK >> GO TO 5.
- NG >> GO TO 4.

4. DETECT MALFUNCTIONING PART

Check the following.

- Harness connectors F102, M82
- Harness for open or short between A/T assembly and "unified meter and A/C amp."

>> Repair open circuit or short to ground or short to power in harness or connectors.

5. CHECK PNP SWITCH INPUT SIGNAL CIRCUIT FOR OPEN AND SHORT-II

1. Disconnect ECM harness connector.
2. Check harness continuity between ECM terminal 102 and “unified meter and A/C amp.” terminal 25.
Refer to Wiring Diagram.

Continuity should exist.

3. Also check harness for short to ground and short to power.

OK or NG

OK >> GO TO 6.

NG >> Repair open circuit or short to ground or short to power in harness or connectors.

6. CHECK PNP SWITCH INPUT SIGNAL CIRCUIT FOR OPEN AND SHORT-III

1. Check harness continuity between A/T assembly terminal 9 and TCM terminal 8.
Refer to [AT-108, "DTC P0615 START SIGNAL CIRCUIT"](#) .

Continuity should exist.

2. Also check harness for short to ground and short to power.

OK or NG

OK >> GO TO 7.

NG >> Repair open circuit or short to ground or short to power in harness or connectors.

7. CHECK INTERMITTENT INCIDENT

Refer to [EC-784, "TROUBLE DIAGNOSIS FOR INTERMITTENT INCIDENT"](#) .

OK or NG

OK >> GO TO 8.

NG >> Repair or replace.

8. REPLACE “UNIFIED METER AND A/C AMP.”

Refer to [DI-28, "UNIFIED METER AND A/C AMP"](#) .

>> INSPECTION END

A

EC

C

D

E

F

G

H

I

J

K

L

M

DTC P1720 VEHICLE SPEED SENSOR (A/T OUTPUT)

PFP:31036

Description

ABS00CD1

NOTE:

If DTC P1720 is displayed with DTC U1000 or U1001, first perform the trouble diagnosis for DTC U1000, U1001. Refer to [EC-792, "DTC U1000, U1001 CAN COMMUNICATION LINE"](#).

ECM receives two vehicle speed sensor signals via CAN communication line. One is sent from “unified meter and A/C amp.”, and the other is from TCM (Transmission control module). ECM uses these two signals for engine control.

CONSULT-II Reference Value in Data Monitor Mode

ABS00CD2

Specification data are reference values.

MONITOR ITEM	CONDITION	SPECIFICATION
VEH SPEED SE	<ul style="list-style-type: none"> Turn drive wheels and compare the CONSULT-II value with speedometer indication 	Almost the same speed as the speedometer indication

On Board Diagnosis Logic

ABS00CD3

The MIL will not light up for this diagnosis.

DTC No.	Trouble diagnosis name	DTC detecting condition	Possible cause
P1720 1720	Vehicle speed sensor (A/T output)	ECM detects a difference between two vehicle speed sensor signals is out of the specified range.	<ul style="list-style-type: none"> Harness or connectors (The CAN communication line is open or shorted) Harness or connectors (Revolution sensor circuit is open or shorted) Harness or connectors (Wheel sensor circuit is open or shorted.) TCM ABS actuator and electric unit (control unit) Unified meter and A/C amp.

DTC Confirmation Procedure

ABS00CD4

CAUTION:

Always drive vehicle at a safe speed.

NOTE:

If DTC Confirmation Procedure has been previously conducted, always turn ignition switch OFF and wait at least 10 seconds before conducting the next test.

 **WITH CONSULT-II**

- Turn ignition switch ON.
- Select “DATA MONITOR” mode with CONSULT-II.
- Start engine.
- Drive vehicle at a speed of 20 km/h (12 MPH) or more for at least 5 seconds without brake pedal depressing.
- If 1st trip DTC is detected, go to [EC-1217, "Diagnostic Procedure"](#).

 **WITH GST**

Follow the procedure “WITH CONSULT-II” above.

Diagnostic Procedure

1. CHECK DTC WITH TCM

Check DTC with TCM. Refer to [AT-42, "TROUBLE DIAGNOSIS"](#) .

OK or NG

OK >> GO TO 2.

NG >> Perform trouble shooting relevant to DTC indicated.

2. CHECK DTC WITH "ABS ACTUATOR AND ELECTRIC UNIT (CONTROL UNIT)"

Check DTC with "ABS actuator and electric unit (control unit)". Refer to [BRC-12, "TROUBLE DIAGNOSIS"](#) .

OK or NG

OK >> GO TO 3.

NG >> Perform trouble shooting relevant to DTC indicated.

3. CHECK "UNIFIED METER AND A/C AMP."

Check combination meter function. Refer to [DI-28, "UNIFIED METER AND A/C AMP"](#) .

>> **INSPECTION END**

A

EC

C

D

E

F

G

H

I

J

K

L

M

DTC P1780 SHIFT CHANGE SIGNAL

PFP:31036

Description

ABS00CD6

NOTE:

If DTC P1780 is displayed with DTC U1000 or U1001, first perform the trouble diagnosis for DTC U1000, U1001. Refer to [EC-792, "DTC U1000, U1001 CAN COMMUNICATION LINE"](#).

ECM receives current gear position signal, next gear position signal, shift change signal, shift pattern signal through CAN communication line from TCM (Transmission control module). ECM uses these four signals for engine control.

On Board Diagnosis Logic

ABS00CD7

The MIL will not light up for this diagnosis.

DTC No.	Trouble diagnosis name	DTC detecting condition		Possible cause
P1780 1780	Shift change signal	A)	The next gear position signal and the current gear position signal are not in the normal pattern compared with the shift pattern signal,	<ul style="list-style-type: none"> ● Harness or connectors (CAN communication line circuit is open or shorted) ● TCM ● A/T assembly
		B)	The next gear position signal and the current gear position signal are different even through the shift change signal is OFF.	

DTC Confirmation Procedure

ABS00CD8

CAUTION:

Always drive vehicle at a safe speed.

NOTE:

If DTC Confirmation Procedure has been previously conducted, always turn ignition switch OFF and wait at least 10 seconds before conducting the next test.

WITH CONSULT-II

1. Perform DTC confirmation procedure for DTC P1754, refer to [AT-154, "DTC Confirmation Procedure"](#).
2. If 1st trip DTC is detected, go to [EC-1218, "Diagnostic Procedure"](#).

WITH GST

Follow the procedure "WITH CONSULT-II" above.

Diagnostic Procedure

ABS00CD9

1. CHECK DTC WITH TCM

Check DTC with TCM. Refer to [AT-42, "TROUBLE DIAGNOSIS"](#).

OK or NG

- OK >> GO TO 2.
- NG >> Perform trouble shooting relevant to DTC indicated.

2. CHECK TCM FUNCTION

Refer to [AT-42, "TROUBLE DIAGNOSIS"](#).

OK or NG

- OK >> GO TO 3.
- NG >> Replace TCM. Refer to [AT-7, "PRECAUTIONS"](#).

3. REPLACE ECM

1. Replace ECM.
2. Perform initialization of IVIS (NATS) system and registration of all IVIS (NATS) ignition key IDs. Refer to [BL-208, "ECM Re-communicating Function"](#) .
3. Perform [EC-698, "Accelerator Pedal Released Position Learning"](#) .
4. Perform [EC-698, "Throttle Valve Closed Position Learning"](#) .
5. Perform [EC-698, "Idle Air Volume Learning"](#) .

>> INSPECTION END

A

EC

C

D

E

F

G

H

I

J

K

L

M

DTC P1805 BRAKE SWITCH

[VK45DE]

DTC P1805 BRAKE SWITCH

PFP:25320

Description

ABS00CDA

Brake switch signal is applied to the ECM through the stop lamp switch when the brake pedal is depressed. This signal is used mainly to decrease the engine speed when the vehicle is driving.

CONSULT-II Reference Value in Data Monitor Mode

ABS00CDB

Specification data are reference values.

MONITOR ITEM	CONDITION		SPECIFICATION
BRAKE SW	● Ignition switch: ON	Brake pedal: Fully released	OFF
		Brake pedal: Slightly depressed	ON

On Board Diagnosis Logic

ABS00CDC

The MIL will not light up for this diagnosis.

DTC No.	Trouble diagnosis name	DTC detecting condition	Possible cause
P1805 1805	Brake switch	A brake switch signal is not sent to ECM for extremely long time while the vehicle is driving.	<ul style="list-style-type: none">● Harness or connectors (Stop lamp switch circuit is open or shorted.)● Stop lamp switch

FAIL-SAFE MODE

When the malfunction is detected, the ECM enters fail-safe mode.

Engine operating condition in fail-safe mode

ECM controls the electric throttle control actuator by regulating the throttle opening to a small range. Therefore, acceleration will be poor.

Vehicle condition	Driving condition
When engine is idling	Normal
When accelerating	Poor acceleration

DTC Confirmation Procedure

ABS00CDD

WITH CONSULT-II

1. Turn ignition switch ON.
2. Fully depress the brake pedal for at least 5 seconds.
3. Erase the DTC with CONSULT-II.
4. Select "DATA MONITOR" mode with CONSULT-II.
5. If 1st trip DTC is detected, go to [EC-1222, "Diagnostic Procedure"](#).

DATA MONITOR	
MONITOR	NO DTC
ENG SPEED	XXX rpm

SEF058Y

WITH GST

Follow the procedure "WITH CONSULT-II" above.

DTC P1805 BRAKE SWITCH

[VK45DE]

Wiring Diagram

ABS00CDE

EC-BRK/SW-01

— : DETECTABLE LINE FOR DTC
 — : NON-DETECTABLE LINE FOR DTC

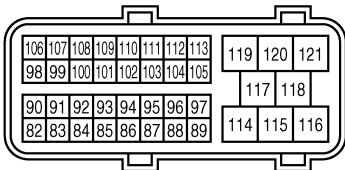
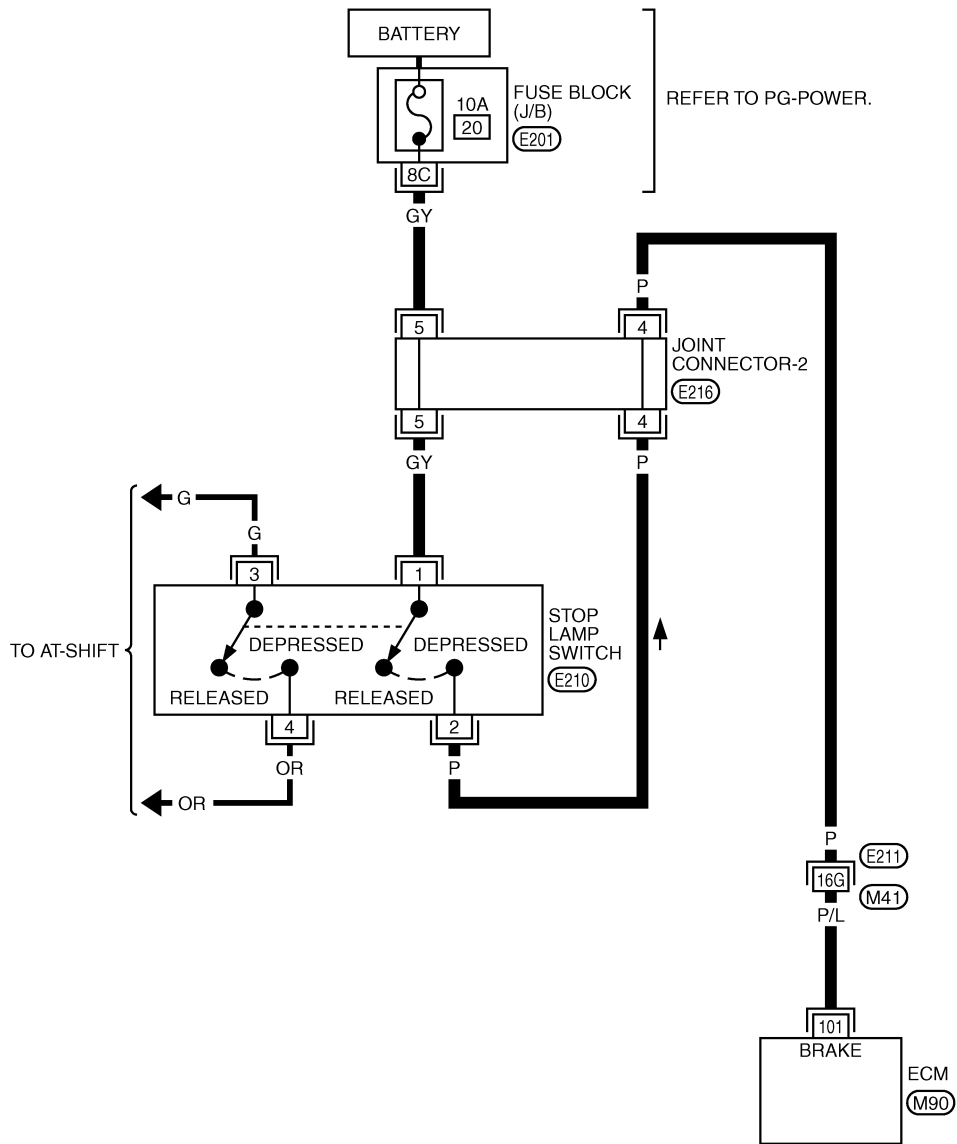

(M90)
B

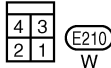

(E210)
W

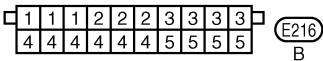

(E216)
B

REFER TO THE FOLLOWING.

(E211) -SUPER MULTIPLE JUNCTION (SMJ)

(E201) -FUSE BLOCK-JUNCTION BOX (J/B)

TBWM0260E

DTC P1805 BRAKE SWITCH

[VK45DE]

Specification data are reference values and are measured between each terminal and ground.

CAUTION:

Do not use ECM ground terminals when measuring input/output voltage. Doing so may result in damage to the ECM's transistor. Use a ground other than ECM terminals, such as the ground.

TER-MINAL NO.	WIRE COLOR	ITEM	CONDITION	DATA (DC Voltage)
101	P/L	Stop lamp switch	[Ignition switch: OFF] ● Brake pedal: Fully released	Approximately 0V
			[Ignition switch: OFF] ● Brake pedal: Slightly depressed	BATTERY VOLTAGE (11 - 14V)

Diagnostic Procedure

ABS00CDF

1. CHECK STOP LAMP SWITCH CIRCUIT

1. Turn ignition switch OFF.
2. Check the stop lamp when depressing and releasing the brake pedal.

Brake pedal	Stop lamp
Fully released	Not illuminated
Slightly depressed	Illuminated

OK or NG

- OK >> GO TO 4.
- NG >> GO TO 2.

2. CHECK STOP LAMP SWITCH POWER SUPPLY CIRCUIT

1. Disconnect stop lamp switch harness connector.

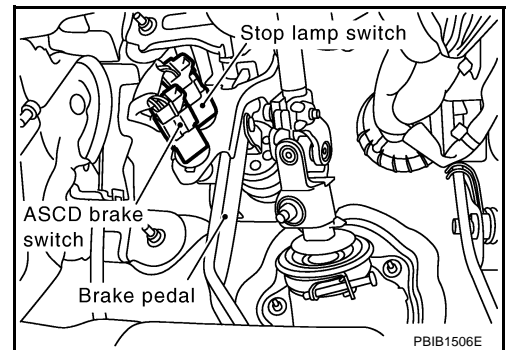

2. Check voltage between stop lamp switch terminal 1 and ground with CONSULT-II or tester.

Voltage: Battery voltage

OK or NG

- OK >> GO TO 4.
- NG >> GO TO 3.

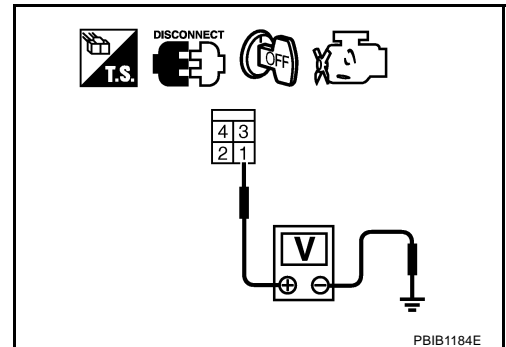

3. DETECT MALFUNCTIONING PART

Check the following.

- 10A fuse
- Fuse block (J/B) connector E201
- Joint connector-2
- Harness for open and short between stop lamp switch and battery

>> Repair open circuit or short to ground or short to power in harness or connectors.

4. CHECK STOP LAMP SWITCH INPUT SIGNAL CIRCUIT FOR OPEN AND SHORT

1. Turn ignition switch OFF.
2. Disconnect ECM harness connector.
3. Disconnect stop lamp switch harness connector.
4. Check harness continuity between ECM terminal 101 and stop lamp switch terminal 2.
Refer to Wiring Diagram.

Continuity should exist.

5. Also check harness for short to ground and short to power.

OK or NG

- OK >> GO TO 6.
NG >> GO TO 5.

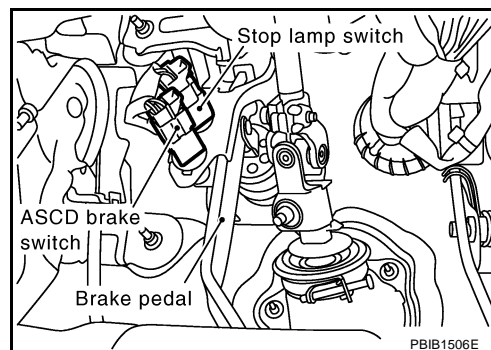

5. DETECT MALFUNCTIONING PART

Check the following.

- Harness connectors E211, M41
- Joint connector-2
- Harness for open or short between ECM and stop lamp switch

>> Repair open circuit or short to ground or short to power in harness or connectors.

6. CHECK STOP LAMP SWITCH

Refer to [EC-1224, "Component Inspection"](#) .

OK or NG

- OK >> GO TO 7.
NG >> Replace stop lamp switch.

7. CHECK INTERMITTENT INCIDENT

Refer to [EC-784, "TROUBLE DIAGNOSIS FOR INTERMITTENT INCIDENT"](#) .

>> **INSPECTION END**

Component Inspection STOP LAMP SWITCH

1. Disconnect stop lamp switch harness connector.

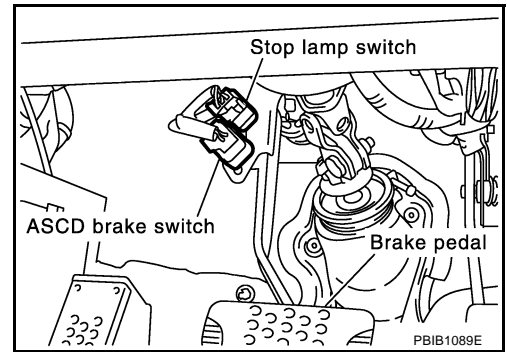

2. Check continuity between stop lamp switch terminals 1 and 2 under the following conditions.

Conditions	Continuity
Brake pedal fully released	Should not exist.
Brake pedal slightly depressed	Should exist.

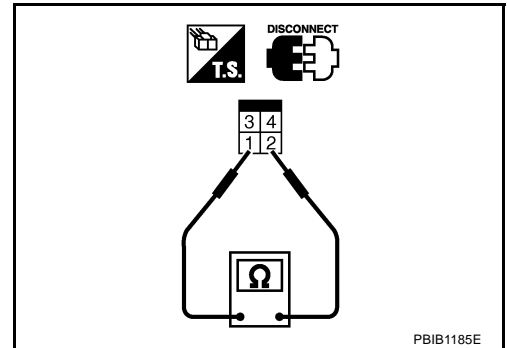

3. If NG, adjust stop lamp switch installation, refer to [BR-6, "BRAKE PEDAL"](#) , and perform step 2 again.

DTC P2122, P2123 APP SENSOR

PFP:18002

Component Description

ABS00CDH

The accelerator pedal position sensor is installed on the upper end of the accelerator pedal assembly. The sensor detects the accelerator position and sends a signal to the ECM.

Accelerator pedal position sensor has two sensors. These sensors are a kind of potentiometers which transform the accelerator pedal position into output voltage, and emit the voltage signal to the ECM. In addition, these sensors detect the opening and closing speed of the accelerator pedal and feed the voltage signals to the ECM. The ECM judges the current opening angle of the accelerator pedal from these signals and controls the throttle control motor based on these signals.

Idle position of the accelerator pedal is determined by the ECM receiving the signal from the accelerator pedal position sensor. The ECM uses this signal for the engine operation such as fuel cut.

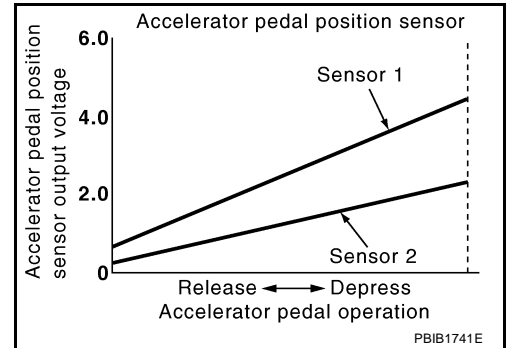

CONSULT-II Reference Value in Data Monitor Mode

ABS00CDI

Specification data are reference values.

MONITOR ITEM	CONDITION		SPECIFICATION
ACCEL SEN1	● Ignition switch: ON (Engine stopped)	Accelerator pedal: Fully released	0.5 - 1.0V
		Accelerator pedal: Fully depressed	4.0 - 4.7V
ACCEL SEN2*	● Ignition switch: ON (Engine stopped)	Accelerator pedal: Fully released	0.3 - 1.2V
		Accelerator pedal: Fully depressed	3.9 - 4.8V
CLSD THL POS	● Ignition switch: ON (Engine stopped)	Accelerator pedal: Fully released	ON
		Accelerator pedal: Slightly depressed	OFF

*: Accelerator pedal position sensor 2 signal is converted by ECM internally. Thus, it differs from ECM terminal voltage.

On Board Diagnosis Logic

ABS00CDJ

These self-diagnoses have the one trip detection logic.

NOTE:

If DTC P2122 or P2123 is displayed with DTC P1229, first perform the trouble diagnosis for DTC P1229. Refer to [EC-1156](#).

DTC No.	Trouble diagnosis name	DTC detecting condition	Possible cause
P2122 2122	Accelerator pedal position sensor 1 circuit low input	An excessively low voltage from the APP sensor 1 is sent to ECM.	● Harness or connectors (APP sensor 1 circuit is open or shorted.) ● Accelerator pedal position sensor (Accelerator pedal position sensor 1)
P2123 2123	Accelerator pedal position sensor 1 circuit high input	An excessively high voltage from the APP sensor 1 is sent to ECM.	

FAIL-SAFE MODE

When the malfunction is detected, ECM enters fail-safe mode and the MIL lights up.

Engine operating condition in fail-safe mode

The ECM controls the electric throttle control actuator in regulating the throttle opening in order for the idle position to be within +10 degrees.

The ECM regulates the opening speed of the throttle valve to be slower than the normal condition.

So, the acceleration will be poor.

DTC Confirmation Procedure

NOTE:

If DTC Confirmation Procedure has been previously conducted, always turn ignition switch OFF and wait at least 10 seconds before conducting the next test.

TESTING CONDITION:

Before performing the following procedure, confirm that battery voltage is more than 10V at idle.

WITH CONSULT-II

1. Turn ignition switch ON.
2. Select "DATA MONITOR" mode with CONSULT-II.
3. Start engine and let it idle for 1 second.
4. If DTC is detected, go to [EC-1228, "Diagnostic Procedure"](#) .

DATA MONITOR	
MONITOR	NO DTC
ENG SPEED	XXX rpm

SEF058Y

WITH GST

Follow the procedure "WITH CONSULT-II" above.



DTC P2122, P2123 APP SENSOR

[VK45DE]

ABS00CDL

Wiring Diagram

EC-APPS1-01

 : DETECTABLE LINE FOR DTC
 : NON-DETECTABLE LINE FOR DTC

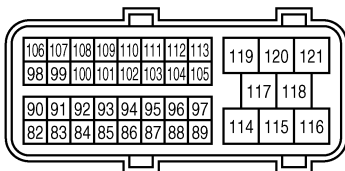
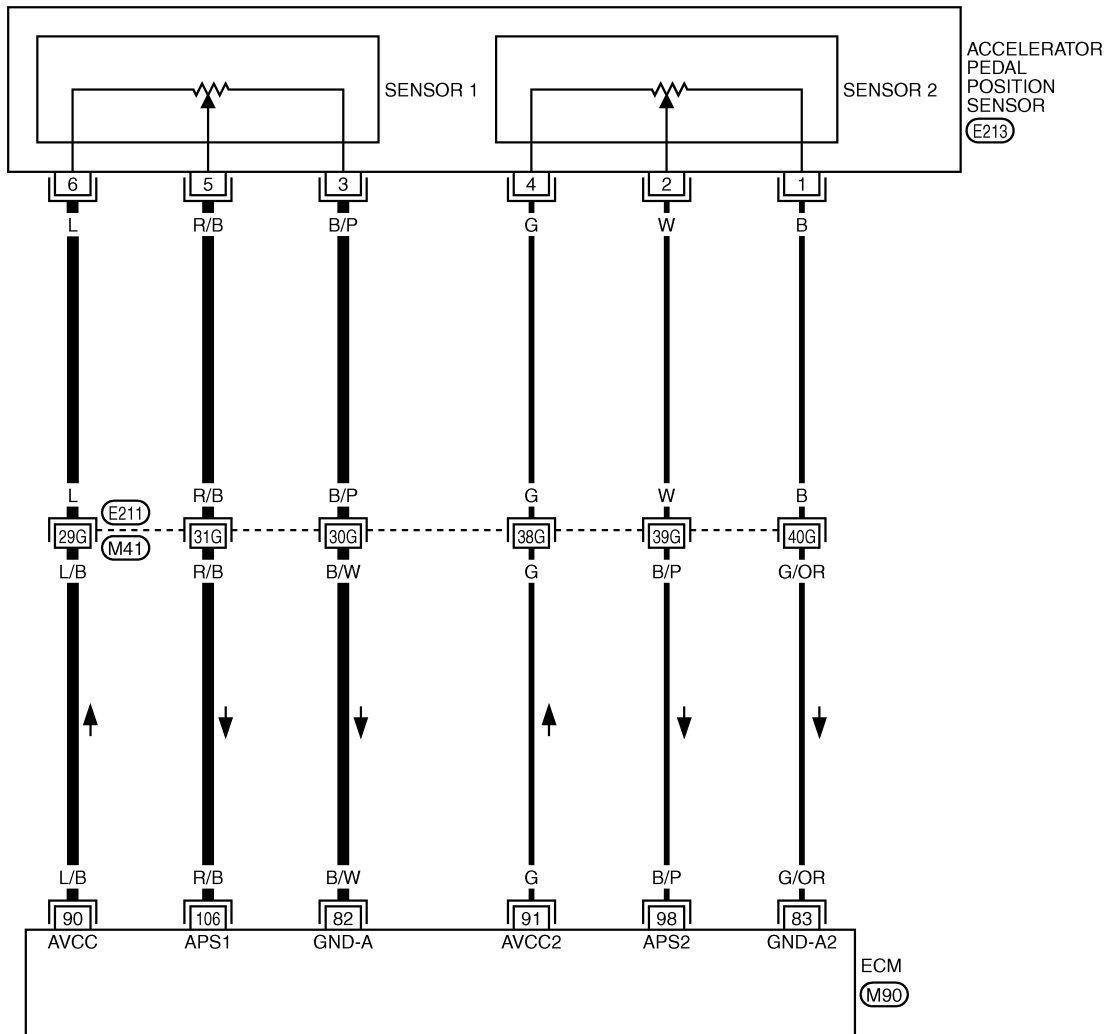

(M90)
B

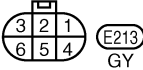

(E213)
GY

REFER TO THE FOLLOWING.
 (E211) -SUPER MULTIPLE JUNCTION (SMJ)

TBWM0239E

DTC P2122, P2123 APP SENSOR

[VK45DE]

Specification data are reference values and are measured between each terminal and ground.

CAUTION:

Do not use ECM ground terminals when measuring input/output voltage. Doing so may result in damage to the ECM's transistor. Use a ground other than ECM terminals, such as the ground.

TER-MINAL NO.	WIRE COLOR	ITEM	CONDITION	DATA (DC Voltage)
82	B/W	Sensor ground (APP sensor 1/Steering switch)	[Engine is running] ● Warm-up condition ● Idle speed	Approximately 0V
83	G/OR	Sensor ground (APP sensor 2)	[Engine is running] ● Warm-up condition ● Idle speed	Approximately 0V
90	L/B	Sensor power supply (APP sensor 1)	[Ignition switch: ON]	Approximately 5V
91	G	Sensor power supply (APP sensor 2)	[Ignition switch: ON]	Approximately 5V
98	B/P	Accelerator pedal position sensor 2	[Ignition switch: ON] ● Engine stopped ● Accelerator pedal is fully released	0.15 - 0.60V
			[Ignition switch: ON] ● Engine stopped ● Accelerator pedal is fully depressed	1.95 - 2.40V
106	R/B	Accelerator pedal position sensor 1	[Ignition switch: ON] ● Engine stopped ● Accelerator pedal is fully released	0.5 - 1.0V
			[Ignition switch: ON] ● Engine stopped ● Accelerator pedal is fully depressed	3.9 - 4.7V

Diagnostic Procedure

ABS00CDM

1. CHECK GROUND CONNECTIONS

1. Turn ignition switch OFF.
2. Loosen and retighten three ground screws on the body.
Refer to [EC-791, "Ground Inspection"](#).

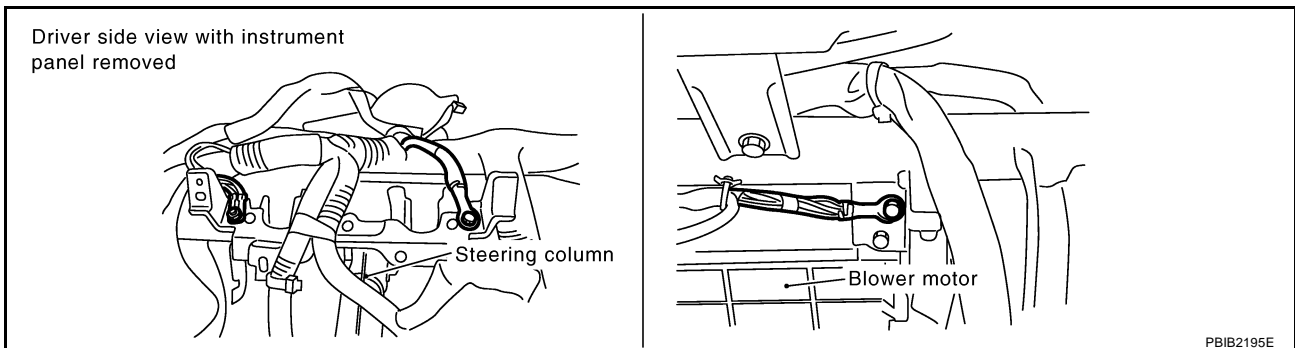

OK or NG

- OK >> GO TO 2.
- NG >> Repair or replace ground connections.

2. CHECK APP SENSOR 1 POWER SUPPLY CIRCUIT

1. Disconnect accelerator pedal position (APP) sensor harness connector.
2. Turn ignition switch ON.

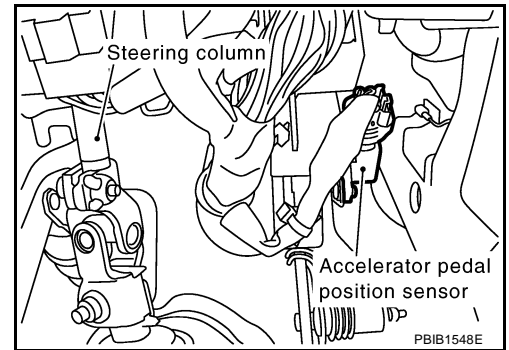

3. Check voltage between APP sensor terminal 6 and ground with CONSULT-II or tester.

Voltage: Approximately 5V

OK or NG

- OK >> GO TO 4.
 NG >> GO TO 3.

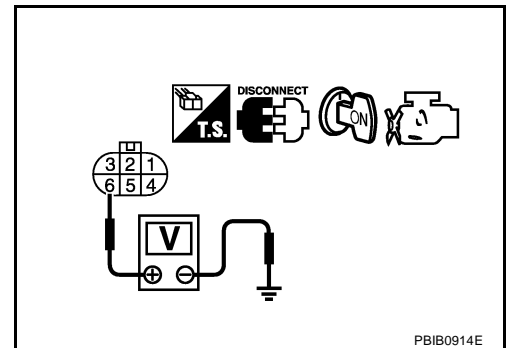

3. DETECT MALFUNCTIONING PART

Check the following.

- Harness connectors E211, M41
- Harness for open or short between ECM and accelerator pedal position sensor

>> Repair open circuit or short to ground or short to power in harness or connectors.

4. CHECK APP SENSOR 1 GROUND CIRCUIT FOR OPEN AND SHORT

1. Turn ignition switch OFF.
2. Disconnect ECM harness connector.
3. Check harness continuity between APP sensor terminal 3 and ECM terminal 82. Refer to Wiring Diagram.

Continuity should exist.

4. Also check harness for short to ground and short to power.

OK or NG

- OK >> GO TO 6.
 NG >> GO TO 5.

5. DETECT MALFUNCTIONING PART

Check the following.

- Harness connectors E211, M41
- Harness for open or short between ECM and accelerator pedal position sensor

>> Repair open circuit or short to ground or short to power in harness or connectors.

6. CHECK APP SENSOR INPUT SIGNAL CIRCUIT FOR OPEN AND SHORT

1. Check harness continuity between ECM terminal 106 and APP sensor terminal 5.
Refer to Wiring Diagram.

Continuity should exist.

2. Also check harness for short to ground and short to power.

OK or NG

- OK >> GO TO 8.
- NG >> GO TO 7.

7. DETECT MALFUNCTIONING PART

Check the following.

- Harness connectors E211, M41
- Harness for open or short between ECM and accelerator pedal position sensor

>> Repair open circuit or short to ground or short to power in harness or connectors.

8. CHECK APP SENSOR

Refer to [EC-1253, "Component Inspection"](#) .

OK or NG

- OK >> GO TO 10.
- NG >> GO TO 9.

9. REPLACE ACCELERATOR PEDAL ASSEMBLY

1. Replace accelerator pedal assembly.
2. Perform [EC-698, "Accelerator Pedal Released Position Learning"](#) .
3. Perform [EC-698, "Throttle Valve Closed Position Learning"](#) .
4. Perform [EC-698, "Idle Air Volume Learning"](#) .

>> INSPECTION END

10. CHECK INTERMITTENT INCIDENT

Refer to [EC-784, "TROUBLE DIAGNOSIS FOR INTERMITTENT INCIDENT"](#) .

>> INSPECTION END

Component Inspection ACCELERATOR PEDAL POSITION SENSOR

ABS00CDN

1. Reconnect all harness connectors disconnected.
2. Turn ignition switch ON.
3. Check voltage between ECM terminals 106 (APP sensor 1 signal), 98 (APP sensor 2 signal) and ground under the following conditions.

Terminal	Accelerator pedal	Voltage
106 (Accelerator pedal position sensor 1)	Fully released	0.5 - 1.0V
	Fully depressed	3.9 - 4.7V
98 (Accelerator pedal position sensor 2)	Fully released	0.15 - 0.60V
	Fully depressed	1.95 - 2.40V

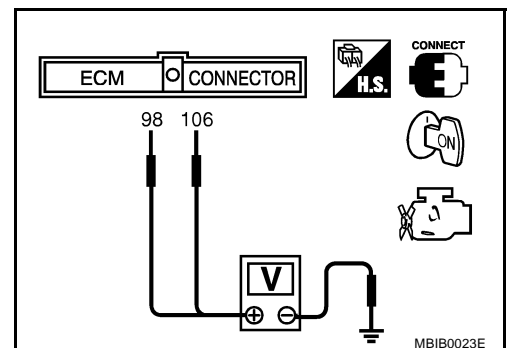

4. If NG, replace accelerator pedal assembly and go to next step.
5. Perform [EC-698, "Accelerator Pedal Released Position Learning"](#) .
6. Perform [EC-698, "Throttle Valve Closed Position Learning"](#) .
7. Perform [EC-698, "Idle Air Volume Learning"](#) .

A

Removal and Installation ACCELERATOR PEDAL

ABS00CDO

EC

Refer to [ACC-3, "ACCELERATOR CONTROL SYSTEM"](#) .

C

D

E

F

G

H

I

J

K

L

M

DTC P2127, P2128 APP SENSOR

PFP:18002

Component Description

ABS00CDP

The accelerator pedal position sensor is installed on the upper end of the accelerator pedal assembly. The sensor detects the accelerator position and sends a signal to the ECM.

Accelerator pedal position sensor has two sensors. These sensors are a kind of potentiometers which transform the accelerator pedal position into output voltage, and emit the voltage signal to the ECM. In addition, these sensors detect the opening and closing speed of the accelerator pedal and feed the voltage signals to the ECM. The ECM judges the current opening angle of the accelerator pedal from these signals and controls the throttle control motor based on these signals.

Idle position of the accelerator pedal is determined by the ECM receiving the signal from the accelerator pedal position sensor. The ECM uses this signal for the engine operation such as fuel cut.

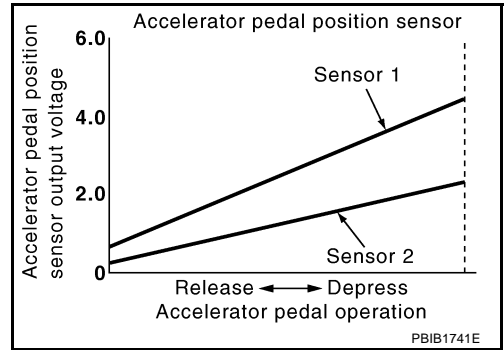

CONSULT-II Reference Value in Data Monitor Mode

ABS00CDO

Specification data are reference values.

MONITOR ITEM	CONDITION		SPECIFICATION
ACCEL SEN1	● Ignition switch: ON (Engine stopped)	Accelerator pedal: Fully released	0.5 - 1.0V
		Accelerator pedal: Fully depressed	4.0 - 4.7V
ACCEL SEN2*	● Ignition switch: ON (Engine stopped)	Accelerator pedal: Fully released	0.3 - 1.2V
		Accelerator pedal: Fully depressed	3.9 - 4.8V
CLSD THL POS	● Ignition switch: ON (Engine stopped)	Accelerator pedal: Fully released	ON
		Accelerator pedal: Slightly depressed	OFF

*: Accelerator pedal position sensor 2 signal is converted by ECM internally. Thus, it differs from ECM terminal voltage.

On Board Diagnosis Logic

ABS00CDD

These self-diagnoses have the one trip detection logic.

DTC No.	Trouble diagnosis name	DTC detecting condition	Possible cause
P2127 2127	Accelerator pedal position sensor 2 circuit low input	An excessively low voltage from the APP sensor 2 is sent to ECM.	<ul style="list-style-type: none"> ● Harness or connectors (APP sensor 2 circuit is open or shorted.) (TP sensor circuit is shorted.) ● Accelerator pedal position sensor (Accelerator pedal position sensor 2) ● Electric throttle control actuator (TP sensor 1 and 2)
P2128 2128	Accelerator pedal position sensor 2 circuit high input	An excessively high voltage from the APP sensor 2 is sent to ECM.	

FAIL-SAFE MODE

When the malfunction is detected, ECM enters fail-safe mode and the MIL lights up.

Engine operating condition in fail-safe mode

The ECM controls the electric throttle control actuator in regulating the throttle opening in order for the idle position to be within +10 degrees.

The ECM regulates the opening speed of the throttle valve to be slower than the normal condition.

So, the acceleration will be poor.

DTC Confirmation Procedure

NOTE:

If DTC Confirmation Procedure has been previously conducted, always turn ignition switch OFF and wait at least 10 seconds before conducting the next test.

TESTING CONDITION:

Before performing the following procedure, confirm that battery voltage is more than 10V at idle.

WITH CONSULT-II

1. Turn ignition switch ON.
2. Select "DATA MONITOR" mode with CONSULT-II.
3. Start engine and let it idle for 1 second.
4. If DTC is detected, go to [EC-1235, "Diagnostic Procedure"](#) .

DATA MONITOR	
MONITOR	NO DTC
ENG SPEED	XXX rpm
<small>SEF058Y</small>	

WITH GST

Follow the procedure "WITH CONSULT-II" above.

A
EC
C
D
E
F
G
H
I
J
K
L
M

DTC P2127, P2128 APP SENSOR

[VK45DE]

Wiring Diagram

ABS00CDT

EC-APPS2-01

: DETECTABLE LINE FOR DTC
 : NON-DETECTABLE LINE FOR DTC

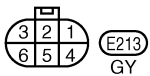
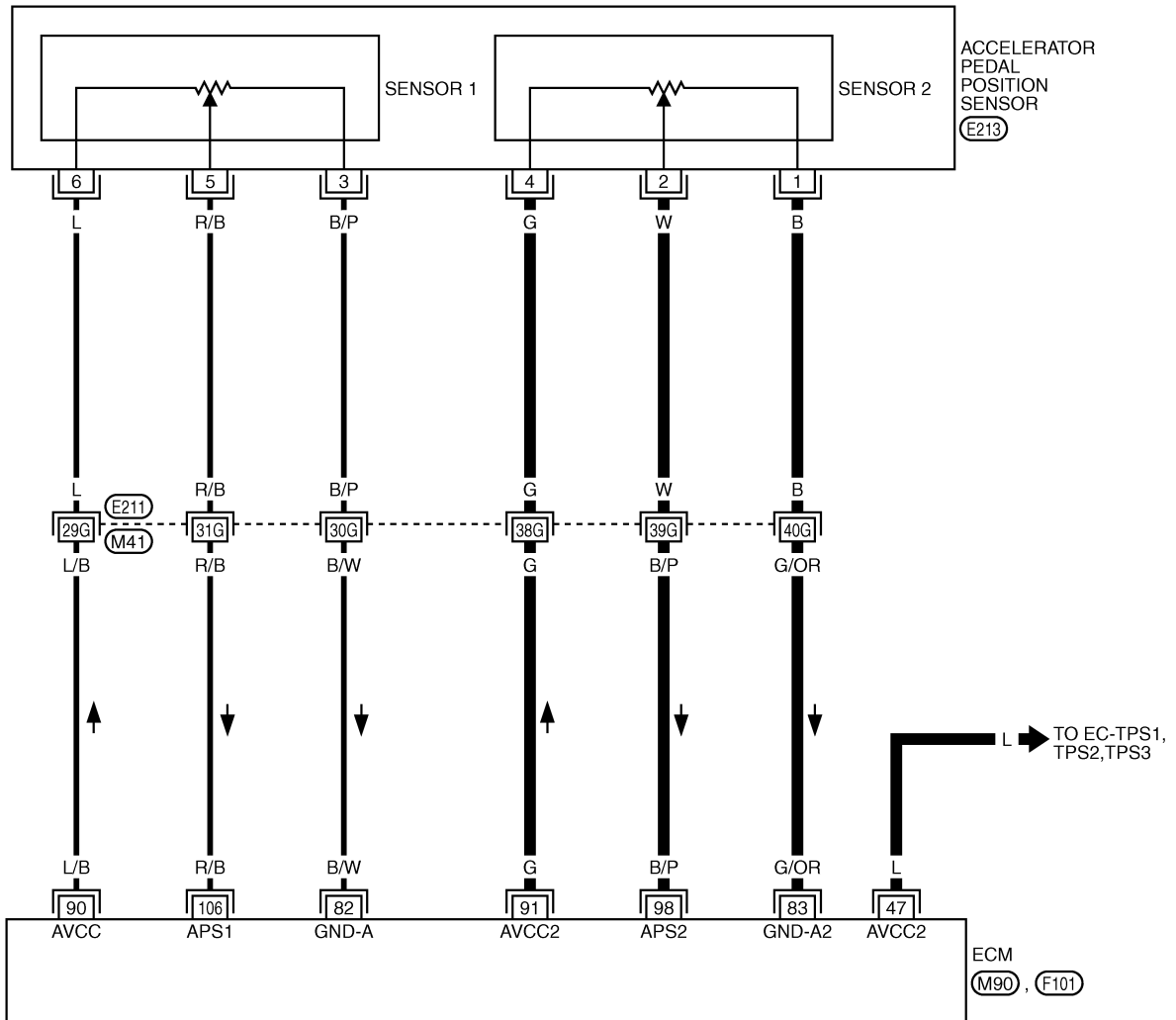

REFER TO THE FOLLOWING.

(E211) -SUPER MULTIPLE JUNCTION (SMJ)

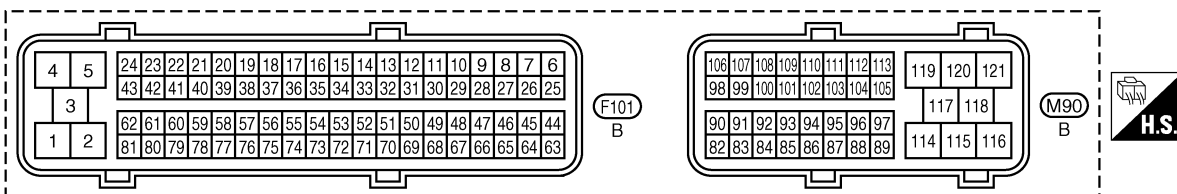

TBWM0508E

DTC P2127, P2128 APP SENSOR

[VK45DE]

Specification data are reference values and are measured between each terminal and ground.

CAUTION:

Do not use ECM ground terminals when measuring input/output voltage. Doing so may result in damage to the ECM's transistor. Use a ground other than ECM terminals, such as the ground.

TER-MINAL NO.	WIRE COLOR	ITEM	CONDITION	DATA (DC Voltage)
47	L	Sensor power supply (Throttle position sensor)	[Ignition switch: ON]	Approximately 5V
82	B/W	Sensor ground (APP sensor 1 / Steering switch)	[Engine is running] ● Warm-up condition ● Idle speed	Approximately 0V
83	G/OR	Sensor ground (APP sensor 2)	[Engine is running] ● Warm-up condition ● Idle speed	Approximately 0V
90	L/B	Sensor power supply (APP sensor 1)	[Ignition switch: ON]	Approximately 5V
91	G	Sensor power supply (APP sensor 2)	[Ignition switch: ON]	Approximately 5V
98	B/P	Accelerator pedal position sensor 2	[Ignition switch: ON] ● Engine stopped ● Accelerator pedal is fully released	0.15 - 0.60V
			[Ignition switch: ON] ● Engine stopped ● Accelerator pedal is fully depressed	1.95 - 2.40V
106	R/B	Accelerator pedal position sensor 1	[Ignition switch: ON] ● Engine stopped ● Accelerator pedal is fully released	0.5 - 1.0V
			[Ignition switch: ON] ● Engine stopped ● Accelerator pedal is fully depressed	3.9 - 4.7V

Diagnostic Procedure

ABS00CDU

1. CHECK GROUND CONNECTIONS

1. Turn ignition switch OFF.
2. Loosen and retighten three ground screws on the body.
Refer to [EC-791, "Ground Inspection"](#).

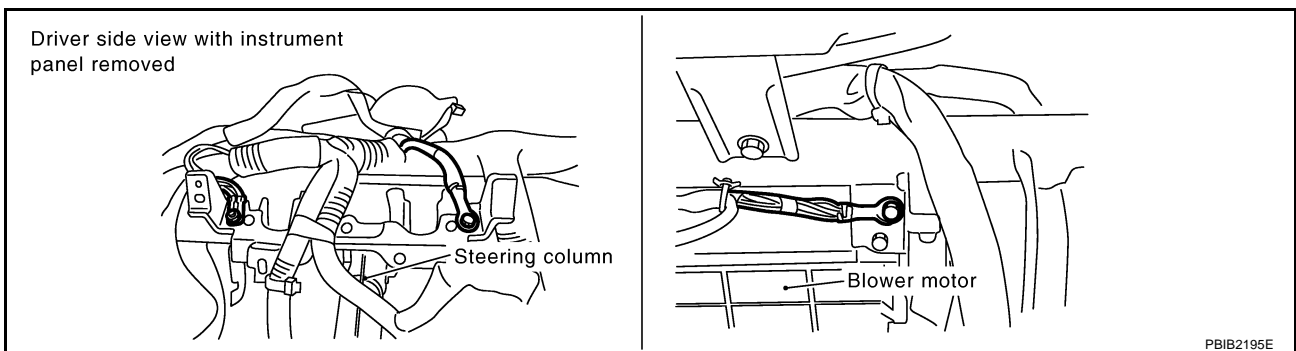

OK or NG

- OK >> GO TO 2.
- NG >> Repair or replace ground connections.

2. CHECK APP SENSOR 2 POWER SUPPLY CIRCUIT-I

1. Disconnect accelerator pedal position (APP) sensor harness connector.
2. Turn ignition switch ON.

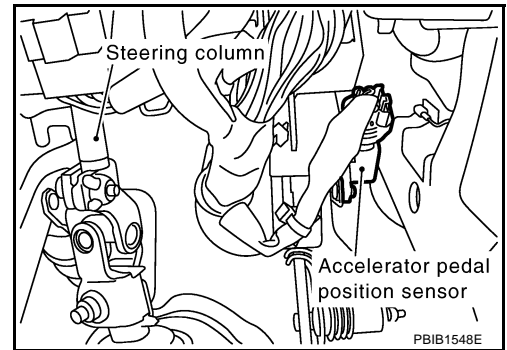

3. Check voltage between APP sensor terminal 4 and ground with CONSULT-II or tester.

Voltage: Approximately 5V

OK or NG

- OK >> GO TO 8.
 NG >> GO TO 3.

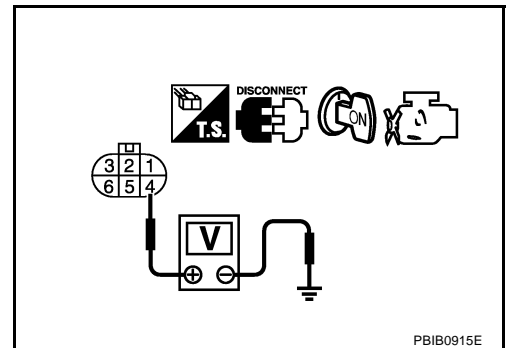

3. CHECK APP SENSOR 2 POWER SUPPLY CIRCUIT-II

1. Turn ignition switch OFF.
2. Disconnect ECM harness connector.
3. Check harness continuity between APP sensor terminal 4 and ECM terminal 91. Refer to Wiring Diagram.

Continuity should exist.

OK or NG

- OK >> GO TO 5.
 NG >> GO TO 4.

4. DETECT MALFUNCTIONING PART

Check the following.

- Harness connectors E211, M41
- Harness for open or short between ECM and accelerator pedal position sensor

>> Repair or replace open circuit.

5. CHECK APP SENSOR 2 POWER SUPPLY CIRCUIT-III

Check harness for short to power and short to ground, between the following terminals.

ECM terminal	Sensor terminal	Reference Wiring Diagram
91	APP sensor terminal 4	EC-1234
47	Electric throttle control actuator terminal 1	EC-850

OK or NG

- OK >> GO TO 6.
 NG >> Repair short to ground or short to power in harness or connectors.

6. CHECK THROTTLE POSITION SENSOR

Refer to [EC-854, "Component Inspection"](#) .

OK or NG

- OK >> GO TO 14.
NG >> GO TO 7.

7. REPLACE ELECTRIC THROTTLE CONTROL ACTUATOR

1. Replace the electric throttle control actuator.
2. Perform [EC-698, "Throttle Valve Closed Position Learning"](#) .
3. Perform [EC-698, "Idle Air Volume Learning"](#) .

>> **INSPECTION END**

8. CHECK APP SENSOR 2 GROUND CIRCUIT FOR OPEN AND SHORT

1. Turn ignition switch OFF.
2. Disconnect ECM harness connector.
3. Check harness continuity between APP sensor terminal 1 and ECM terminal 83.
Refer to Wiring Diagram.

Continuity should exist.

4. Also check harness for short to ground and short to power.

OK or NG

- OK >> GO TO 10.
NG >> GO TO 9.

9. DETECT MALFUNCTIONING PART

Check the following.

- Harness connectors E211, M41
- Harness for open or short between ECM and accelerator pedal position sensor

>> Repair open circuit or short to ground or short to power in harness or connectors.

10. CHECK APP SENSOR 2 INPUT SIGNAL CIRCUIT FOR OPEN AND SHORT

1. Check harness continuity between ECM terminal 98 and APP sensor terminal 2.
Refer to Wiring Diagram.

Continuity should exist.

2. Also check harness for short to ground and short to power.

OK or NG

- OK >> GO TO 12.
NG >> GO TO 11.

11. DETECT MALFUNCTIONING PART

Check the following.

- Harness connectors E211, M41
- Harness for open or short between ECM and accelerator pedal position sensor

>> Repair open circuit or short to ground or short to power in harness or connectors.

12. CHECK APP SENSOR

Refer to [EC-1253, "Component Inspection"](#) .

OK or NG

- OK >> GO TO 14.
- NG >> GO TO 13.

13. REPLACE ACCELERATOR PEDAL ASSEMBLY

1. Replace accelerator pedal assembly.
2. Perform [EC-698, "Accelerator Pedal Released Position Learning"](#) .
3. Perform [EC-698, "Throttle Valve Closed Position Learning"](#) .
4. Perform [EC-698, "Idle Air Volume Learning"](#) .

>> INSPECTION END

14. CHECK INTERMITTENT INCIDENT

Refer to [EC-784, "TROUBLE DIAGNOSIS FOR INTERMITTENT INCIDENT"](#) .

>> INSPECTION END

Component Inspection ACCELERATOR PEDAL POSITION SENSOR

ABS00CDV

1. Reconnect all harness connectors disconnected.
2. Turn ignition switch ON.
3. Check voltage between ECM terminals 106 (APP sensor 1 signal), 98 (APP sensor 2 signal) and ground under the following conditions.

Terminal	Accelerator pedal	Voltage
106 (Accelerator pedal position sensor 1)	Fully released	0.5 - 1.0V
	Fully depressed	3.9 - 4.7V
98 (Accelerator pedal position sensor 2)	Fully released	0.15 - 0.60V
	Fully depressed	1.95 - 2.40V

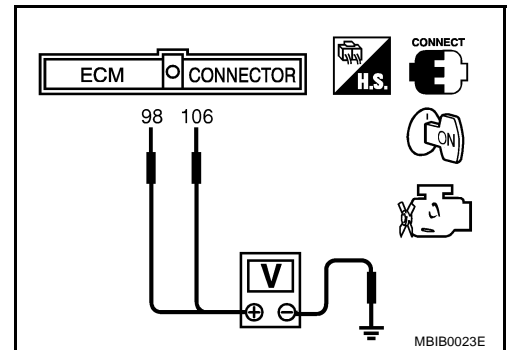

4. If NG, replace accelerator pedal assembly and go to next step.
5. Perform [EC-698, "Accelerator Pedal Released Position Learning"](#) .
6. Perform [EC-698, "Throttle Valve Closed Position Learning"](#) .
7. Perform [EC-698, "Idle Air Volume Learning"](#) .

Removal and Installation ACCELERATOR PEDAL

ABS00CDW

Refer to [ACC-3, "ACCELERATOR CONTROL SYSTEM"](#) .

DTC P2135 TP SENSOR

Component Description

ABS00CDX

Electric throttle control actuator consists of throttle control motor, throttle position sensor, etc. The throttle position sensor responds to the throttle valve movement.

The throttle position sensor has the two sensors. These sensors are a kind of potentiometers which transform the throttle valve position into output voltage, and emit the voltage signal to the ECM. In addition, these sensors detect the opening and closing speed of the throttle valve and feed the voltage signals to the ECM. The ECM judges the current opening angle of the throttle valve from these signals and the ECM controls the throttle control motor to make the throttle valve opening angle properly in response to driving condition.

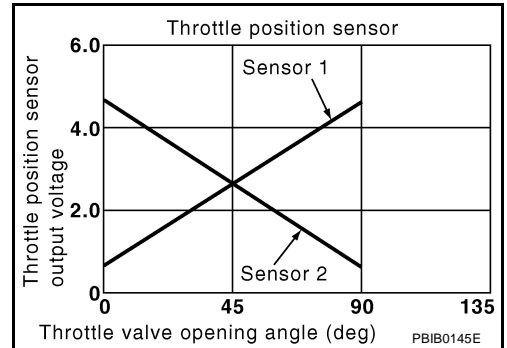

CONSULT-II Reference Value in Data Monitor Mode

ABS00CDY

Specification data are reference values.

MONITOR ITEM	CONDITION		SPECIFICATION
THRTL SEN1 THRTL SEN2*	<ul style="list-style-type: none"> Ignition switch: ON (Engine stopped) Shift lever: D 	Accelerator pedal: Fully released	More than 0.36V
		Accelerator pedal: Fully depressed	Less than 4.75V

*: Throttle position sensor 2 signal is converted by ECM internally. Thus, it differs from ECM terminal voltage signal.

On Board Diagnosis Logic

ABS00CDZ

This self-diagnosis has the one trip detection logic.

DTC No.	Trouble diagnosis name	DTC detecting condition	Possible cause
P2135 2135	Throttle position sensor circuit range/performance problem	Rationally incorrect voltage is sent to ECM compared with the signals from TP sensor 1 and TP sensor 2.	<ul style="list-style-type: none"> Harness or connector (TP sensor 1 and 2 circuit is open or shorted.) (APP sensor 2 circuit is shorted.) Electric throttle control actuator (TP sensor 1 and 2) Accelerator pedal position sensor

FAIL-SAFE MODE

When the malfunction is detected, the ECM enters fail-safe mode and the MIL lights up.

Engine operation condition in fail-safe mode

The ECM controls the electric throttle control actuator in regulating the throttle opening in order for the idle position to be within +10 degrees.
 The ECM regulates the opening speed of the throttle valve to be slower than the normal condition.
 So, the acceleration will be poor.

DTC Confirmation Procedure**NOTE:**

If DTC Confirmation Procedure has been previously conducted, always turn ignition switch OFF and wait at least 10 seconds before conducting the next test.

TESTING CONDITION:

Before performing the following procedure, confirm that battery voltage is more than 10V at idle.

 **WITH CONSULT-II**

1. Turn ignition switch ON.
2. Select "DATA MONITOR" mode with CONSULT-II.
3. Start engine and let it idle for 1 second.
4. If DTC is detected, go to [EC-1242, "Diagnostic Procedure"](#) .

DATA MONITOR	
MONITOR	NO DTC
ENG SPEED	XXX rpm

SEF058Y

 **WITH GST**

Follow the procedure "WITH CONSULT-II" above.

DTC P2135 TP SENSOR

[VK45DE]

Wiring Diagram

ABS00CE1

EC-TPS3-01

: DETECTABLE LINE FOR DTC
 : NON-DETECTABLE LINE FOR DTC

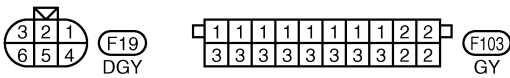
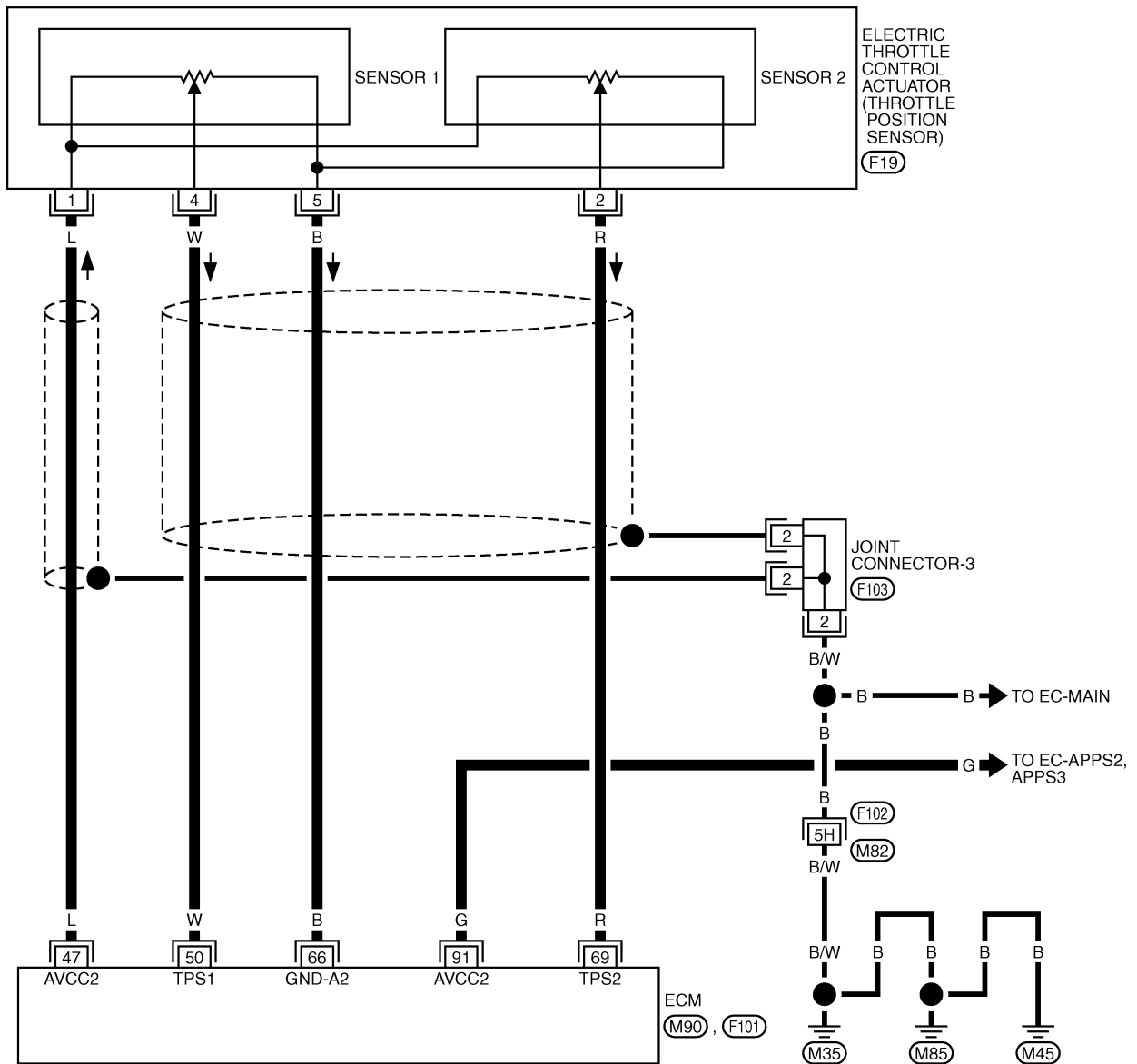

REFER TO THE FOLLOWING.
 (F102) -SUPER MULTIPLE JUNCTION (SMJ)

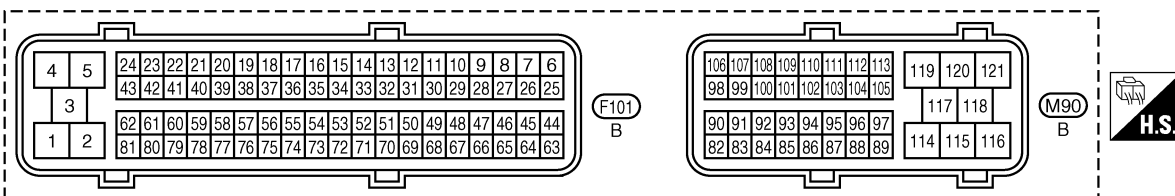

TBWM0427E

DTC P2135 TP SENSOR

[VK45DE]

Specification data are reference values and are measured between each terminal and ground.

CAUTION:

Do not use ECM ground terminals when measuring input/output voltage. Doing so may result in damage to the ECM's transistor. Use a ground other than ECM terminals, such as the ground.

TER-MINAL NO.	WIRE COLOR	ITEM	CONDITION	DATA (DC Voltage)
47	L	Sensor power supply (Throttle position sensor)	[Ignition switch: ON]	Approximately 5V
50	W	Throttle position sensor 1	[Ignition switch: ON] ● Engine stopped ● Shift lever: D ● Accelerator pedal is fully released	More than 0.36V
			[Ignition switch: ON] ● Engine stopped ● Shift lever: D ● Accelerator pedal is fully depressed	Less than 4.75V
66	B	Sensor ground (Throttle position sensor)	[Engine is running] ● Warm-up condition ● Idle speed	Approximately 0V
69	R	Throttle position sensor 2	[Ignition switch: ON] ● Engine stopped ● Shift lever: D ● Accelerator pedal is fully released	Less than 4.75V
			[Ignition switch: ON] ● Engine stopped ● Shift lever: D ● Accelerator pedal is fully depressed	More than 0.36V
91	G	Sensor power supply (APP sensor 2)	[Ignition switch: ON]	Approximately 5V

Diagnostic Procedure

ABS00CE2

1. CHECK GROUND CONNECTIONS

1. Turn ignition switch OFF.
2. Loosen and retighten three ground screws on the body. Refer to [EC-791, "Ground Inspection"](#).

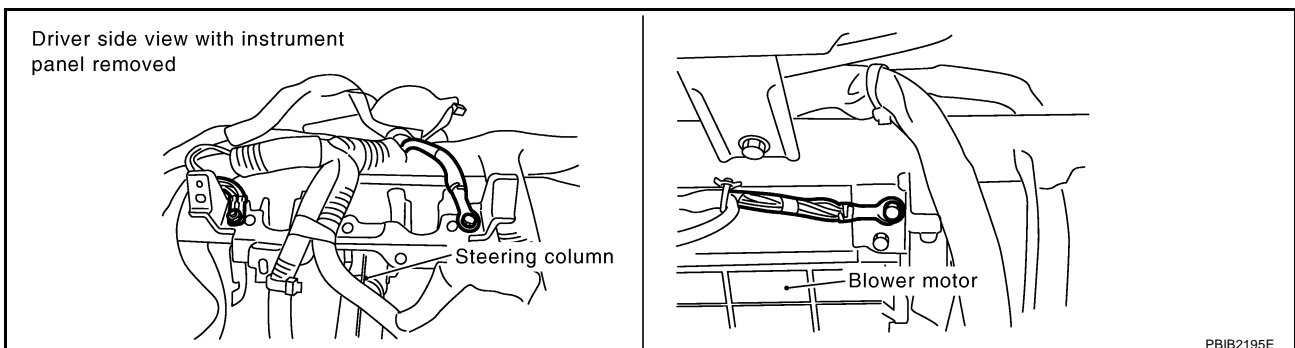

OK or NG

- OK >> GO TO 2.
- NG >> Repair or replace ground connections.

2. CHECK THROTTLE POSITION SENSOR POWER SUPPLY CIRCUIT-I

1. Disconnect electric throttle control actuator harness connector.
2. Turn ignition switch ON.

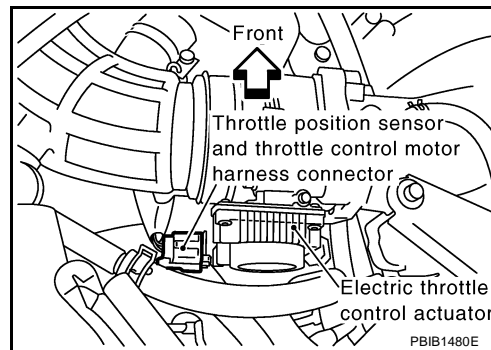

3. Check voltage between electric throttle control actuator terminal 1 and ground with CONSULT-II or tester.

Voltage: Approximately 5V

OK or NG

- OK >> GO TO 7.
- NG >> GO TO 3.

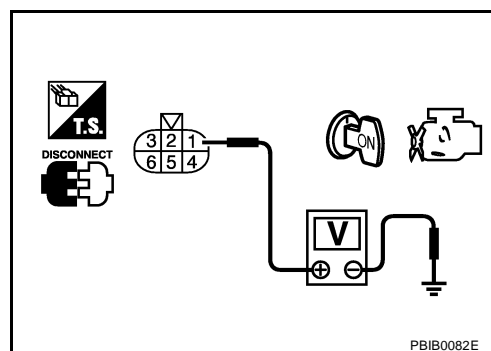

3. CHECK THROTTLE POSITION SENSOR POWER SUPPLY CIRCUIT-II

1. Turn ignition switch OFF.
2. Disconnect ECM harness connector.
3. Check harness continuity between electric throttle control actuator terminal 1 and ECM terminal 47. Refer to Wiring Diagram.

Continuity should exist.

OK or NG

- OK >> GO TO 4.
- NG >> Repair or replace open circuit.

4. CHECK THROTTLE POSITION SENSOR POWER SUPPLY CIRCUIT-III

Check harness for short to power and short to ground, between the following terminals.

ECM terminal	Sensor terminal	Reference Wiring Diagram
47	Electric throttle control actuator terminal 1	EC-1241
91	APP sensor terminal 4	EC-1234

OK or NG

- OK >> GO TO 5.
- NG >> Repair short to ground or short to power in harness or connectors.

5. CHECK APP SENSOR

Refer to [EC-1238, "Component Inspection"](#).

OK or NG

- OK >> GO TO 11.
- NG >> GO TO 6.

6. REPLACE ACCELERATOR PEDAL ASSEMBLY

1. Replace accelerator pedal assembly.
2. Perform [EC-698, "Accelerator Pedal Released Position Learning"](#) .
3. Perform [EC-698, "Throttle Valve Closed Position Learning"](#) .
4. Perform [EC-698, "Idle Air Volume Learning"](#) .

>> INSPECTION END

7. CHECK THROTTLE POSITION SENSOR GROUND CIRCUIT FOR OPEN AND SHORT

1. Turn ignition switch OFF.
2. Disconnect ECM harness connector.
3. Check harness continuity between electric throttle control actuator terminal 5 and ECM terminal 66.
Refer to Wiring Diagram.

Continuity should exist.

4. Also check harness for short to ground and short to power.

OK or NG

OK >> GO TO 8.

NG >> Repair open circuit or short to ground or short to power in harness or connectors.

8. CHECK THROTTLE POSITION SENSOR INPUT SIGNAL CIRCUIT FOR OPEN AND SHORT

1. Check harness continuity between ECM terminal 50 and electric throttle control actuator terminal 4, ECM terminal 69 and electric throttle control actuator terminal 2.
Refer to Wiring Diagram.

Continuity should exist.

2. Also check harness for short to ground and short to power.

OK or NG

OK >> GO TO 9.

NG >> Repair open circuit or short to ground or short to power in harness or connectors.

9. CHECK THROTTLE POSITION SENSOR

Refer to [EC-854, "Component Inspection"](#) .

OK or NG

OK >> GO TO 11.

NG >> GO TO 10.

10. REPLACE ELECTRIC THROTTLE CONTROL ACTUATOR

1. Replace the electric throttle control actuator.
2. Perform [EC-698, "Throttle Valve Closed Position Learning"](#) .
3. Perform [EC-698, "Idle Air Volume Learning"](#) .

>> INSPECTION END

11. CHECK INTERMITTENT INCIDENT

Refer to [EC-784, "TROUBLE DIAGNOSIS FOR INTERMITTENT INCIDENT"](#) .

>> INSPECTION END

Component Inspection THROTTLE POSITION SENSOR

1. Reconnect all harness connectors disconnected.
2. Perform [EC-698, "Throttle Valve Closed Position Learning"](#) .
3. Turn ignition switch ON.
4. Set selector lever to D position.
5. Check voltage between ECM terminals 50 (TP sensor 1 signal), 69 (TP sensor 2 signal) and ground under the following conditions.

Terminal	Accelerator pedal	Voltage
50 (Throttle position sensor 1)	Fully released	More than 0.36V
	Fully depressed	Less than 4.75V
69 (Throttle position sensor 2)	Fully released	Less than 4.75V
	Fully depressed	More than 0.36V

6. If NG, replace electric throttle control actuator and go to the next step.
7. Perform [EC-698, "Throttle Valve Closed Position Learning"](#) .
8. Perform [EC-698, "Idle Air Volume Learning"](#) .

Removal and Installation ELECTRIC THROTTLE CONTROL ACTUATOR

Refer to [EM-174, "INTAKE MANIFOLD"](#) .

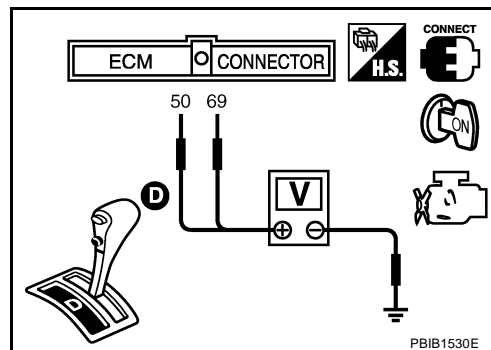

PBIB1530E

DTC P2138 APP SENSOR

PF18002

Component Description

ABS00CE5

The accelerator pedal position sensor is installed on the upper end of the accelerator pedal assembly. The sensor detects the accelerator position and sends a signal to the ECM.

Accelerator pedal position sensor has two sensors. These sensors are a kind of potentiometers which transform the accelerator pedal position into output voltage, and emit the voltage signal to the ECM. In addition, these sensors detect the opening and closing speed of the accelerator pedal and feed the voltage signals to the ECM. The ECM judges the current opening angle of the accelerator pedal from these signals and controls the throttle control motor based on these signals.

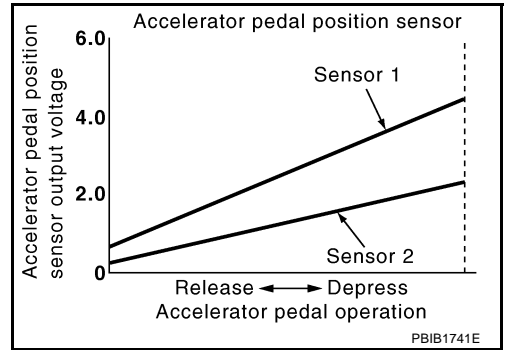

Idle position of the accelerator pedal is determined by the ECM receiving the signal from the accelerator pedal position sensor. The ECM uses this signal for the engine operation such as fuel cut.

CONSULT-II Reference Value in Data Monitor Mode

ABS00CE6

Specification data are reference values.

MONITOR ITEM	CONDITION		SPECIFICATION
ACCEL SEN1	● Ignition switch: ON (Engine stopped)	Accelerator pedal: Fully released	0.5 - 1.0V
		Accelerator pedal: Fully depressed	4.0 - 4.7V
ACCEL SEN2*	● Ignition switch: ON (Engine stopped)	Accelerator pedal: Fully released	0.3 - 1.2V
		Accelerator pedal: Fully depressed	3.9 - 4.8V
CLSD THL POS	● Ignition switch: ON (Engine stopped)	Accelerator pedal: Fully released	ON
		Accelerator pedal: Slightly depressed	OFF

*: Accelerator pedal position sensor 2 signal is converted by ECM internally. Thus, it differs from ECM terminal voltage.

On Board Diagnosis Logic

ABS00CE7

This self-diagnosis has the one trip detection logic.

NOTE:

If DTC P2138 is displayed with DTC P1229, first perform the trouble diagnosis for DTC P1229. Refer to [EC-1156](#).

DTC No.	Trouble diagnosis name	DTC detecting condition	Possible cause
P2138 2138	Accelerator pedal position sensor circuit range/performance problem	Rationally incorrect voltage is sent to ECM compared with the signals from APP sensor 1 and APP sensor 2.	<ul style="list-style-type: none"> ● Harness or connector (APP sensor 1 and 2 circuit is open or shorted.) (TP sensor circuit is shorted.) ● Accelerator pedal position sensor 1 and 2 ● Electric throttle control actuator (TP sensor 1 and 2)

FAIL-SAFE MODE

When the malfunction is detected, ECM enters fail-safe mode and the MIL lights up.

Engine operating condition in fail-safe mode

The ECM controls the electric throttle control actuator in regulating the throttle opening in order for the idle position to be within +10 degrees.

The ECM regulates the opening speed of the throttle valve to be slower than the normal condition.

So, the acceleration will be poor.

DTC Confirmation Procedure

NOTE:

If DTC Confirmation Procedure has been previously conducted, always turn ignition switch OFF and wait at least 10 seconds before conducting the next test.

TESTING CONDITION:

Before performing the following procedure, confirm that battery voltage is more than 10V at idle.

WITH CONSULT-II

1. Turn ignition switch ON.
2. Select "DATA MONITOR" mode with CONSULT-II.
3. Start engine and let it idle for 1 second.
4. If DTC is detected, go to [EC-1249, "Diagnostic Procedure"](#) .

DATA MONITOR	
MONITOR	NO DTC
ENG SPEED	XXX rpm

SEF058Y

WITH GST

Follow the procedure "WITH CONSULT-II" above.

A
EC
C
D
E
F
G
H
I
J
K
L
M

DTC P2138 APP SENSOR

[VK45DE]

ABS00CE9

Wiring Diagram

EC-APPS3-01

: DETECTABLE LINE FOR DTC
 : NON-DETECTABLE LINE FOR DTC

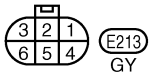
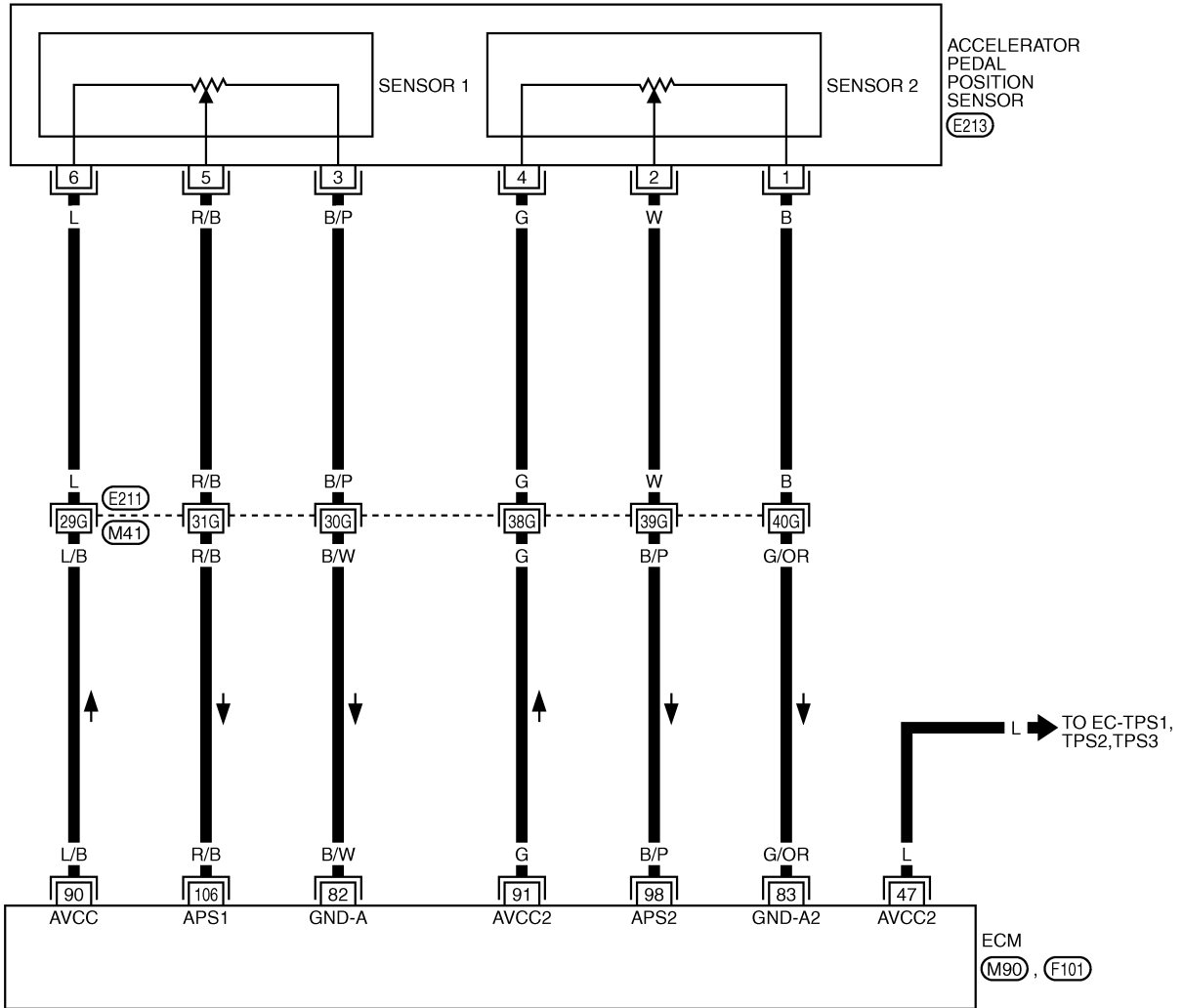

REFER TO THE FOLLOWING.

E211 -SUPER MULTIPLE JUNCTION (SMJ)

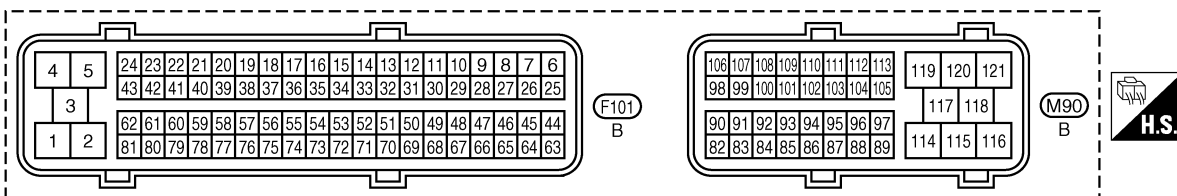

TBWM0509E

DTC P2138 APP SENSOR

[VK45DE]

Specification data are reference values and are measured between each terminal and ground.

CAUTION:

Do not use ECM ground terminals when measuring input/output voltage. Doing so may result in damage to the ECM's transistor. Use a ground other than ECM terminals, such as the ground.

TER-MINAL NO.	WIRE COLOR	ITEM	CONDITION	DATA (DC Voltage)
47	L	Sensor power supply (Throttle position sensor)	[Ignition switch: ON]	Approximately 5V
82	B/W	Sensor ground (APP sensor 1 / Steering switch)	[Engine is running] ● Warm-up condition ● Idle speed	Approximately 0V
83	G/OR	Sensor ground (APP sensor 2)	[Engine is running] ● Warm-up condition ● Idle speed	Approximately 0V
90	L/B	Sensor power supply (APP sensor 1)	[Ignition switch: ON]	Approximately 5V
91	G	Sensor power supply (APP sensor 2)	[Ignition switch: ON]	Approximately 5V
98	B/P	Accelerator pedal position sensor 2	[Ignition switch: ON] ● Engine stopped ● Accelerator pedal is fully released	0.15 - 0.60V
			[Ignition switch: ON] ● Engine stopped ● Accelerator pedal is fully depressed	1.95 - 2.40V
106	R/B	Accelerator pedal position sensor 1	[Ignition switch: ON] ● Engine stopped ● Accelerator pedal is fully released	0.5 - 1.0V
			[Ignition switch: ON] ● Engine stopped ● Accelerator pedal is fully depressed	3.9 - 4.7V

Diagnostic Procedure

ABS00CEA

1. CHECK GROUND CONNECTIONS

1. Turn ignition switch OFF.
2. Loosen and retighten three ground screws on the body.
Refer to [EC-791, "Ground Inspection"](#).

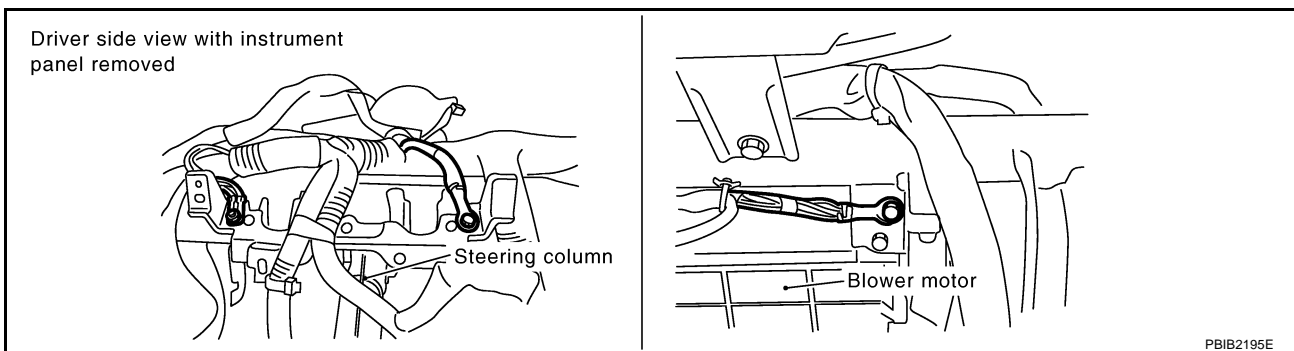

OK or NG

- OK >> GO TO 2.
- NG >> Repair or replace ground connections.

2. CHECK APP SENSOR 1 POWER SUPPLY CIRCUIT

1. Disconnect accelerator pedal position (APP) sensor harness connector.
2. Turn ignition switch ON.

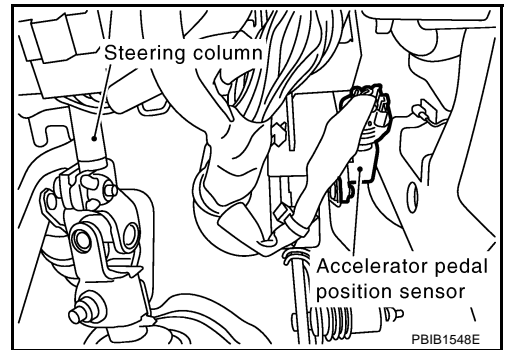

3. Check voltage between APP sensor terminal 6 and ground with CONSULT-II or tester.

Voltage: Approximately 5V

OK or NG

- OK >> GO TO 4.
- NG >> GO TO 3.

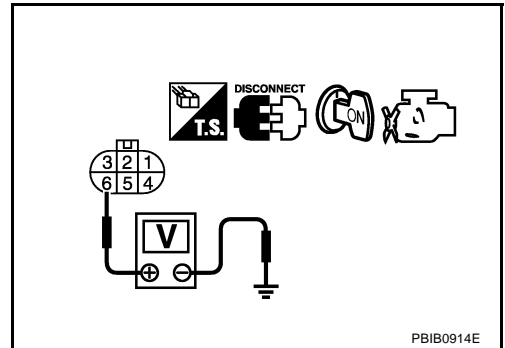

3. DETECT MALFUNCTIONING PART

Check the following.

- Harness connectors E211, M41
- Harness for open or short between ECM and accelerator pedal position sensor

>> Repair open circuit or short to ground or short to power in harness or connectors.

4. CHECK APP SENSOR 2 POWER SUPPLY CIRCUIT-I

Check voltage between APP sensor terminal 4 and ground with CONSULT-II or tester.

Voltage: Approximately 5V

OK or NG

- OK >> GO TO 10.
- NG >> GO TO 5.

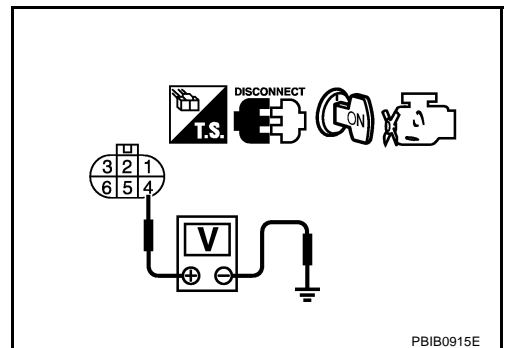

5. CHECK APP SENSOR 2 POWER SUPPLY CIRCUIT-II

1. Turn ignition switch OFF.
2. Disconnect ECM harness connector.
3. Check harness continuity between APP sensor terminal 4 and ECM terminal 91.
Refer to Wiring Diagram.

Continuity should exist.

OK or NG

- OK >> GO TO 7.
NG >> GO TO 6.

6. DETECT MALFUNCTIONING PART

Check the following.

- Harness connectors E211, M41
- Harness for open or short between ECM and accelerator pedal position sensor

>> Repair or replace open circuit.

7. CHECK APP SENSOR 2 POWER SUPPLY CIRCUIT-III

Check harness for short to power and short to ground, between the following terminals.

ECM terminal	Sensor terminal	Reference Wiring Diagram
91	APP sensor terminal 4	EC-1248
47	Electric throttle control actuator terminal 1	EC-850

OK or NG

- OK >> GO TO 8.
NG >> Repair short to ground or short to power in harness or connectors.

8. CHECK THROTTLE POSITION SENSOR

Refer to [EC-854, "Component Inspection"](#) .

OK or NG

- OK >> GO TO 16.
NG >> GO TO 9.

9. REPLACE ELECTRIC THROTTLE CONTROL ACTUATOR

1. Replace the electric throttle control actuator.
2. Perform [EC-698, "Throttle Valve Closed Position Learning"](#) .
3. Perform [EC-698, "Idle Air Volume Learning"](#) .

>> **INSPECTION END**

10. CHECK APP SENSOR GROUND CIRCUIT FOR OPEN AND SHORT

1. Turn ignition switch OFF.
2. Disconnect ECM harness connector.
3. Check harness continuity between APP sensor terminal 3 and ECM terminal 82, APP sensor terminal 1 and ECM terminal 83.
Refer to Wiring Diagram.

Continuity should exist.

4. Also check harness for short to ground and short to power.

OK or NG

- OK >> GO TO 12.
NG >> GO TO 11.

11. DETECT MALFUNCTIONING PART

Check the following.

- Harness connectors E211, M41
- Harness for open or short between ECM and accelerator pedal position sensor

>> Repair open circuit or short to ground or short to power in harness or connectors.

12. CHECK APP SENSOR INPUT SIGNAL CIRCUIT FOR OPEN AND SHORT

1. Check harness continuity between ECM terminal 106 and APP sensor terminal 5, ECM terminal 98 and APP sensor terminal 2.
Refer to Wiring Diagram.

Continuity should exist.

2. Also check harness for short to ground and short to power.

OK or NG

- OK >> GO TO 14.
NG >> GO TO 13.

13. DETECT MALFUNCTIONING PART

Check the following.

- Harness connectors E211, M41
- Harness for open or short between ECM and accelerator pedal position sensor

>> Repair open circuit or short to ground or short to power in harness or connectors.

14. CHECK APP SENSOR

Refer to [EC-1253, "Component Inspection"](#) .

OK or NG

- OK >> GO TO 16.
NG >> GO TO 15.

15. REPLACE ACCELERATOR PEDAL ASSEMBLY

1. Replace accelerator pedal assembly.
2. Perform [EC-698, "Accelerator Pedal Released Position Learning"](#) .
3. Perform [EC-698, "Throttle Valve Closed Position Learning"](#) .
4. Perform [EC-698, "Idle Air Volume Learning"](#) .

>> INSPECTION END

16. CHECK INTERMITTENT INCIDENT

Refer to [EC-784, "TROUBLE DIAGNOSIS FOR INTERMITTENT INCIDENT"](#) .

>> INSPECTION END

**Component Inspection
ACCELERATOR PEDAL POSITION SENSOR**

ABS00CEB

1. Reconnect all harness connectors disconnected.
2. Turn ignition switch ON.
3. Check voltage between ECM terminals 106 (APP sensor 1 signal), 98 (APP sensor 2 signal) and ground under the following conditions.

Terminal	Accelerator pedal	Voltage
106 (Accelerator pedal position sensor 1)	Fully released	0.5 - 1.0V
	Fully depressed	3.9 - 4.7V
98 (Accelerator pedal position sensor 2)	Fully released	0.15 - 0.60V
	Fully depressed	1.95 - 2.40V

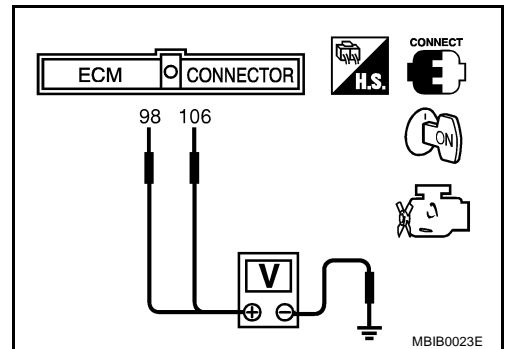

4. If NG, replace accelerator pedal assembly and go to next step.
5. Perform [EC-698, "Accelerator Pedal Released Position Learning"](#) .
6. Perform [EC-698, "Throttle Valve Closed Position Learning"](#) .
7. Perform [EC-698, "Idle Air Volume Learning"](#) .

**Removal and Installation
ACCELERATOR PEDAL**

ABS00CEC

Refer to [ACC-3, "ACCELERATOR CONTROL SYSTEM"](#) .

VARIABLE INDUCTION AIR CONTROL SYSTEM (VIAS)

PFP:14956

Description SYSTEM DESCRIPTION

ABS00CED

Sensor	Input signal to ECM	ECM function	Actuator
Mass air flow sensor	Amount of intake air	VIAS control	VIAS control solenoid valve
Throttle position sensor	Throttle position		
Accelerator pedal position sensor	Accelerator pedal position		
Battery	Battery voltage*		
Crankshaft position sensor (POS) Camshaft position sensor (PHASE)	Engine speed*		
Engine coolant temperature sensor	Engine coolant temperature		

*: The ECM determines the start signal status by the signals of engine speed and battery voltage.

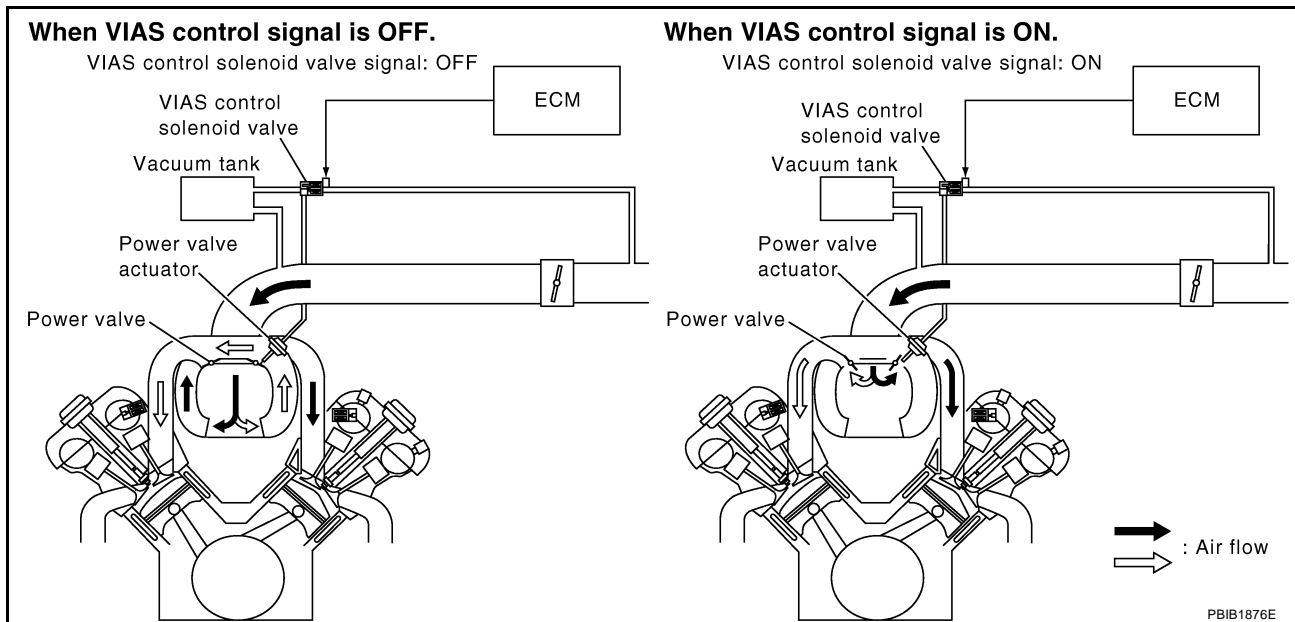

When the engine is running at low or medium speed, the power valve is fully closed. Under this condition, the effective suction port length is equivalent to the total length of the intake manifold collector's suction port including the intake valve. This long suction port provides increased air intake which results in improved suction efficiency and higher torque generation.

The surge tank and one-way valve are provided. When engine is running at high speed, the ECM sends the signal to the VIAS control solenoid valve. This signal introduces the intake manifold vacuum into the power valve actuator and therefore opens the power valve to two suction passages together in the collector.

Under this condition, the effective port length is equivalent to the length of the suction port provided independently for each cylinder. This shortened port length results in enhanced engine output with reduced suction resistance under high speeds.

The power valve is always open regardless of the engine speed when gear position is in N or P.

COMPONENT DESCRIPTION

Power Valve

The power valve is installed in intake manifold collector and used to control the suction passage of the variable induction air control system. It is set in the fully closed or fully opened position by the power valve actuator operated by the vacuum stored in the surge tank. The vacuum in the surge tank is controlled by the VIAS control solenoid valve.

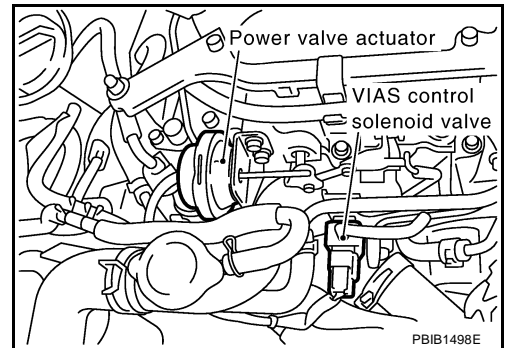

VIAS Control Solenoid Valve

The VIAS control solenoid valve cuts the intake manifold vacuum signal for power valve control. It responds to ON/OFF signals from the ECM. When the solenoid is off, the vacuum signal from the intake manifold is cut. When the ECM sends an ON signal the coil pulls the plunger downward and feeds the vacuum signal to the power valve actuator.

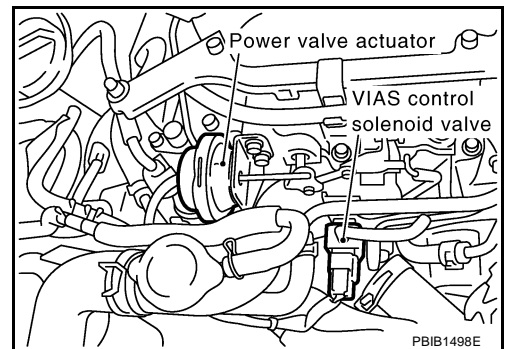

CONSULT-II Reference Value in Data Monitor Mode

ABS00CEE

MONITOR ITEM	CONDITION		SPECIFICATION
VIAS S/V	Engine speed: Idle	Gear position: P or N	ON
		Except above	OFF

A
EC
C
D
E
F
G
H
I
J
K
L
M

VARIABLE INDUCTION AIR CONTROL SYSTEM (VIAS)

[VK45DE]

Wiring Diagram

ABS00CEF

EC-VIAS/V-01

: DETECTABLE LINE FOR DTC
 : NON-DETECTABLE LINE FOR DTC

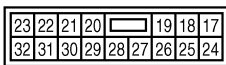
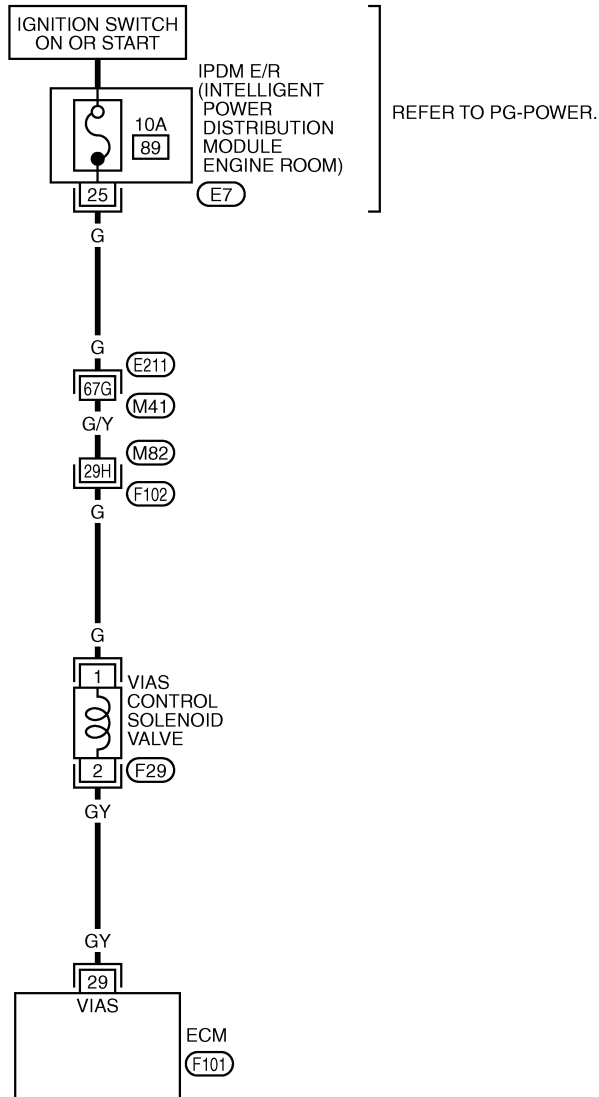

E7
GY

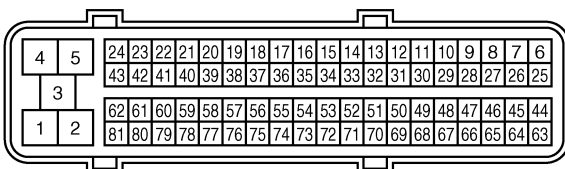

F101
B



REFER TO THE FOLLOWING.

(E21), (F102) -SUPER MULTIPLE JUNCTION (SMJ)

TBWM0270E

VARIABLE INDUCTION AIR CONTROL SYSTEM (VIAS)

[VK45DE]

Specification data are reference values and are measured between each terminal and ground.

CAUTION:

Do not use ECM ground terminals when measuring input/output voltage. Doing so may result in damage to the ECM's transistor. Use a ground other than ECM terminals, such as the ground.

TER-MINAL NO.	WIRE COLOR	ITEM	CONDITION	DATA (DC Voltage)
29	GY	VIAS control solenoid valve	[Engine is running] ● Shift lever position is P or N	0 - 1.0V
			[Engine is running] ● Shift lever position is D	BATTERY VOLTAGE (11 - 14V)
			[Engine is running] ● Engine speed is above 5,000 rpm	0 - 1.0V

Diagnostic Procedure

ABS00CEG

1. CHECK OVERALL FUNCTION

With CONSULT-II

1. Start engine and warm it up to normal operating temperature.
2. Perform "VIAS SOL VALVE" in "ACTIVE TEST" mode with CONSULT-II.
3. Turn VIAS control solenoid valve ON and OFF, and make sure that power valve actuator rod moves.

ACTIVE TEST	
VIAS SOL VALVE	OFF
MONITOR	
ENG SPEED	XXX rpm

Without CONSULT-II

1. Lift up the vehicle.
2. Start engine and warm it up to normal operating temperature.
3. Make sure that power valve actuator rod moves when changing the gear position to N and D alternately.

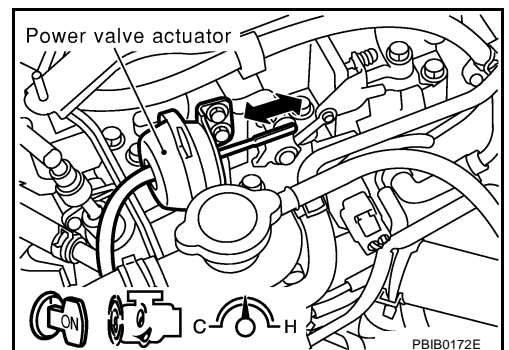

OK or NG

- OK >> INSPECTION END
- NG (With CONSULT-II)>>GO TO 2.
- NG (Without CONSULT-II)>>GO TO 3.

2. CHECK VACUUM EXISTENCE

With CONSULT-II

1. Stop engine and disconnect vacuum hose connected to power valve actuator.
2. Start engine and let it idle.
3. Perform "VIAS SOL VALVE" in "ACTIVE TEST" mode with CONSULT-II.
4. Turn VIAS control solenoid valve ON and OFF, and check vacuum existence under the following conditions.

ACTIVE TEST	
VIAS SOL VALVE	OFF
MONITOR	
ENG SPEED	XXX rpm

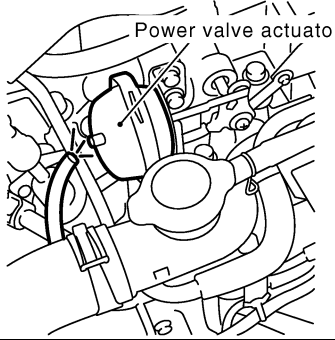

PBIB0174E

VIAS SOL VALVE	Vacuum
ON	Should exist.
OFF	Should not exist.

OK or NG

- OK >> Repair or replace power valve actuator.
- NG >> GO TO 4.

3. CHECK VACUUM EXISTENCE

Without CONSULT-II

1. Stop engine and disconnect vacuum hose connected to power valve actuator.
2. Disconnect VIAS control solenoid valve harness connector.
3. Start engine and let it idle.
4. Apply 12V of direct current between VIAS control solenoid valve terminals 1 and 2.
5. Check vacuum existence under the following conditions.

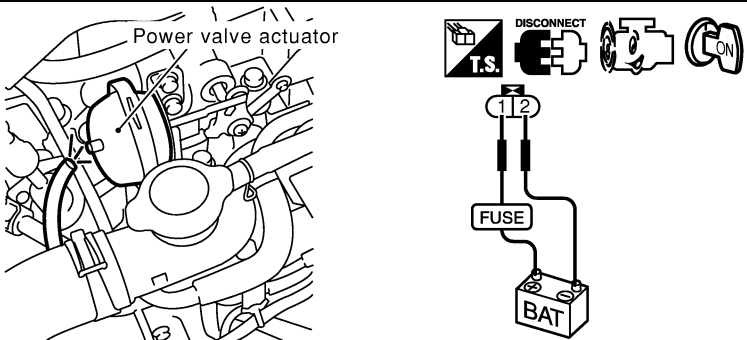

PBIB0175E

Condition	Vacuum
12V direct current supply	Should exist.
No supply	Should not exist.

OK or NG

- OK >> Repair or replace power valve actuator.
- NG >> GO TO 4.

4. CHECK VACUUM HOSE

1. Stop engine.
2. Check hoses and tubes between intake manifold and power valve actuator for crack, clogging, improper connection or disconnection. Refer to [EC-677, "Vacuum Hose Drawing"](#).

OK or NG

- OK >> GO TO 5.
- NG >> Repair hoses or tubes.

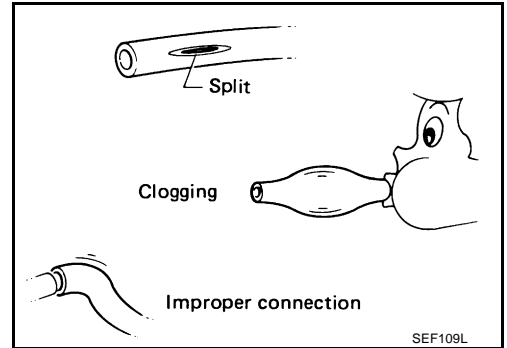

5. CHECK VACUUM TANK

Refer to [EC-1260, "Component Inspection"](#).

OK or NG

- OK >> GO TO 6.
- NG >> Replace vacuum tank.

6. CHECK VIAS CONTROL SOLENOID VALVE POWER SUPPLY CIRCUIT

1. Turn ignition switch OFF.
2. Disconnect VIAS control solenoid valve harness connector.
3. Turn ignition switch ON.

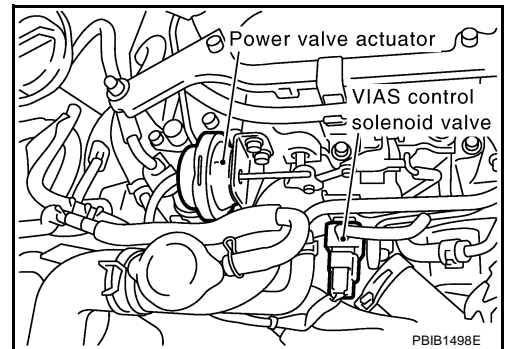

4. Check voltage between terminal 1 and ground with CONSULT-II or tester.

Voltage: Battery voltage

OK or NG

- OK >> GO TO 8.
- NG >> GO TO 7.

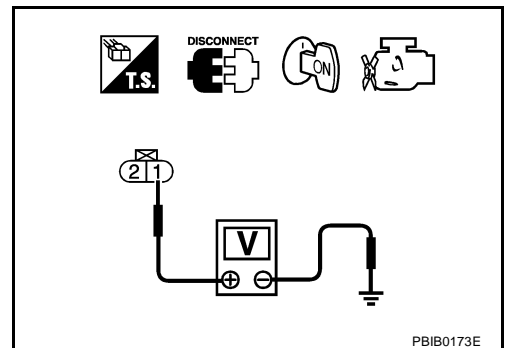

7. DETECT MALFUNCTIONING PART

Check the following.

- Harness connectors E211, M41
- Harness connectors M82, F102
- IPDM E/R connector E7
- 10A fuse
- Harness continuity between IPDM E/R and VIAS control solenoid valve

>> Repair open circuit or short to ground or short to power in harness or connectors.

8. CHECK VIAS CONTROL SOLENOID VALVE OUTPUT SIGNAL CIRCUIT FOR OPEN AND SHORT

1. Turn ignition switch OFF.
2. Disconnect ECM harness connector.
3. Check harness continuity between ECM terminal 29 and VIAS control solenoid valve terminal 2. Refer to Wiring Diagram.

Continuity should exist.

4. Also check harness for short to ground and short to power.

OK or NG

OK >> GO TO 9.

NG >> Repair open circuit or short to ground or short to power in harness or connectors.

9. CHECK VIAS CONTROL SOLENOID VALVE

Refer to [EC-1260, "Component Inspection"](#) .

OK or NG

OK >> GO TO 10.

NG >> Replace VIAS control solenoid valve.

10. CHECK INTERMITTENT INCIDENT

Refer to [EC-784, "TROUBLE DIAGNOSIS FOR INTERMITTENT INCIDENT"](#) .

>> INSPECTION END

Component Inspection VIAS CONTROL SOLENOID VALVE

ABS00CEH

④ With CONSULT-II

1. Reconnect harness connectors disconnected.
2. Turn ignition switch ON.
3. Perform "VIAS SOL VALVE" in "ACTIVE TEST" mode.
4. Check air passage continuity and operation delay time under the following conditions.

Condition VIAS SOL VALVE	Air passage continuity between A and B	Air passage continuity between A and C
ON	Yes	No
OFF	No	Yes

Operation takes less than 1 second.

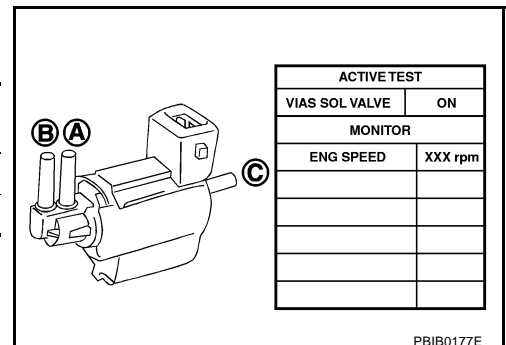

VARIABLE INDUCTION AIR CONTROL SYSTEM (VIAS)

[VK45DE]

With GST

Check air passage continuity and operation delay time under the following conditions.

Condition	Air passage continuity between A and B	Air passage continuity between A and C
12V direct current supply between terminals 1 and 2	Yes	No
No supply	No	Yes

Operation takes less than 1 second.

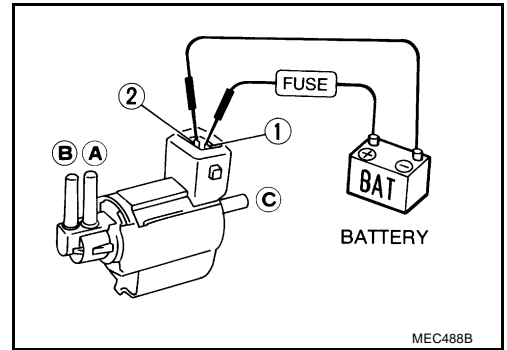

VACUUM TANK

1. Disconnect vacuum hose connected to vacuum tank.
2. Connect a vacuum pump to the port A of vacuum tank.
3. Apply vacuum and make sure that vacuum exists at the port B.

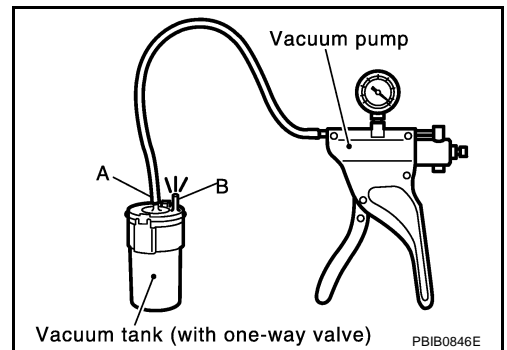

Removal and Installation VIAS CONTROL SOLENOID VALVE

Refer to [EM-174, "INTAKE MANIFOLD"](#) .

A
EC
C
D
E
F
G
H
I
J
K
L
M

IGNITION SIGNAL

PFP:22448

Component Description IGNITION COIL & POWER TRANSISTOR

ABS00CEJ

The ignition signal from the ECM is sent to and amplified by the power transistor. The power transistor turns ON and OFF the ignition coil primary circuit. This ON/OFF operation induces the proper high voltage in the coil secondary circuit.

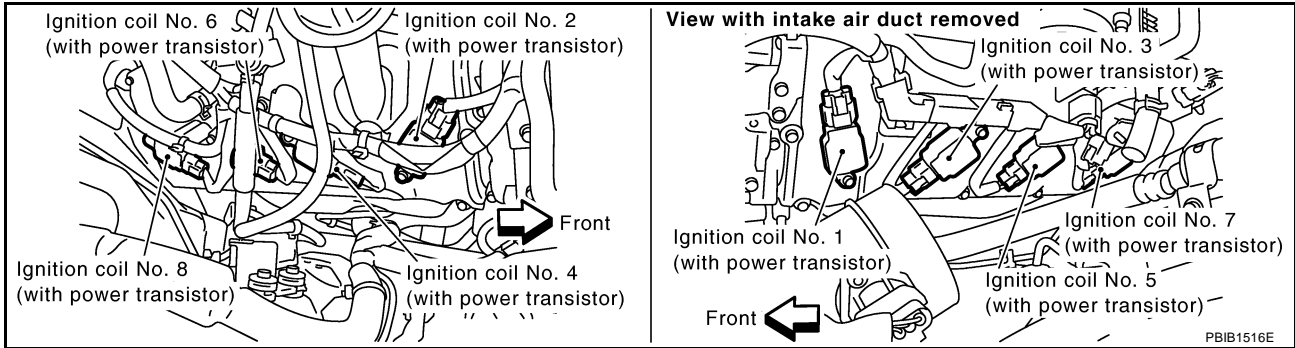

IGNITION SIGNAL

[VK45DE]

ABS00CEK

Wiring Diagram

EC-IGNSYS-01

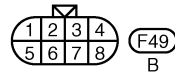
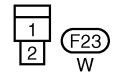
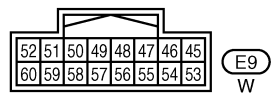
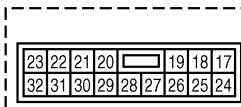
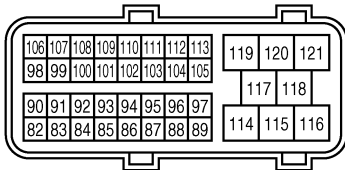
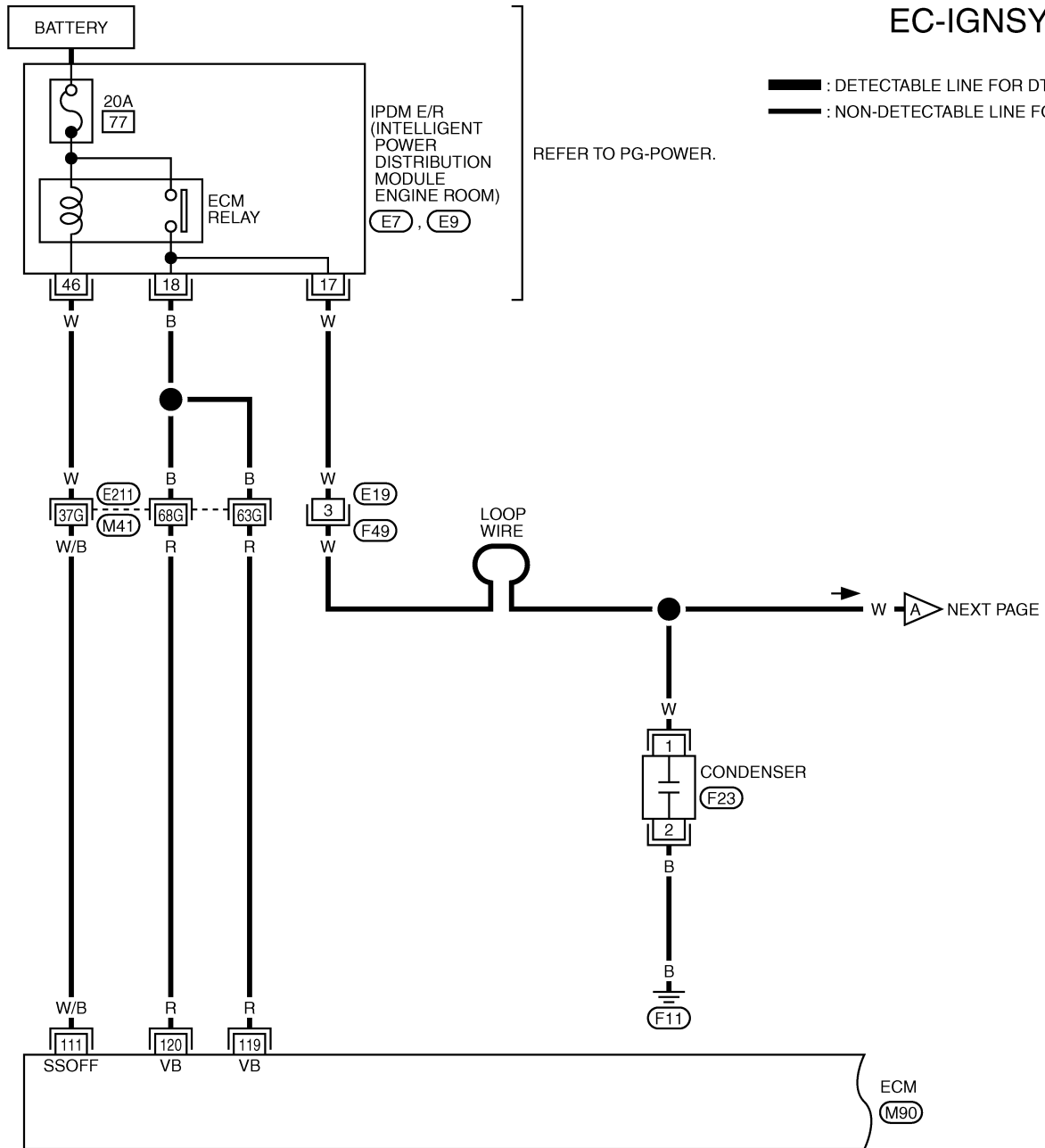

REFER TO THE FOLLOWING.
 (E21) -SUPER MULTIPLE JUNCTION (SMJ)

TBWM0261E

IGNITION SIGNAL

[VK45DE]

Specification data are reference values and are measured between each terminal and ground.

CAUTION:

Do not use ECM ground terminals when measuring input/output voltage. Doing so may result in damage to the ECM's transistor. Use a ground other than ECM terminals, such as the ground.

TER-MINAL NO.	WIRE COLOR	ITEM	CONDITION	DATA (DC Voltage)
111	W/B	ECM relay (Self shut-off)	[Engine is running] [Ignition switch: OFF] <ul style="list-style-type: none">● For a few seconds after turning ignition switch OFF	0 - 1.5V
			[Ignition switch: OFF] <ul style="list-style-type: none">● More than a few seconds after turning ignition switch OFF	BATTERY VOLTAGE (11 - 14V)
119 120	R R	Power supply for ECM	[Ignition switch: ON]	BATTERY VOLTAGE (11 - 14V)

IGNITION SIGNAL

[VK45DE]

EC-IGNSYS-02

— : DETECTABLE LINE FOR DTC
 - - - : NON-DETECTABLE LINE FOR DTC

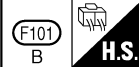
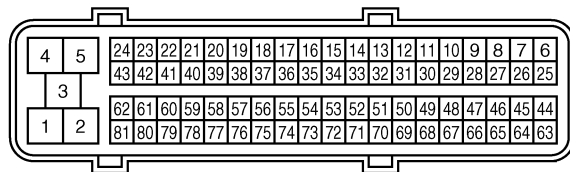
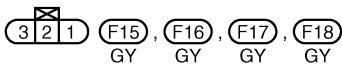
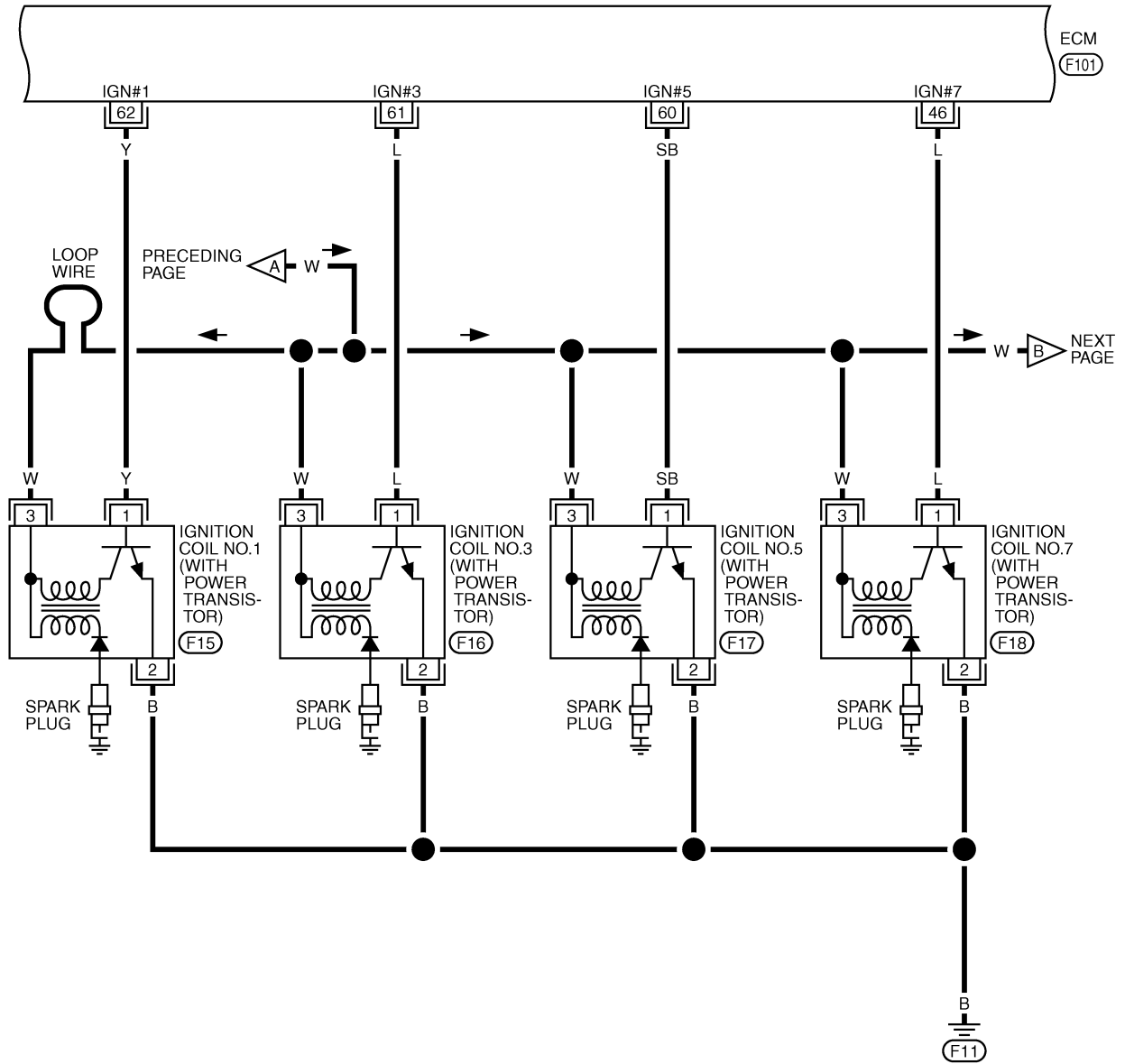

TBWM0262E

IGNITION SIGNAL

[VK45DE]

Specification data are reference values and are measured between each terminal and ground.
Pulse signal is measured by CONSULT-II.

CAUTION:

Do not use ECM ground terminals when measuring input/output voltage. Doing so may result in damage to the ECM's transistor. Use a ground other than ECM terminals, such as the ground.

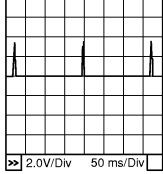
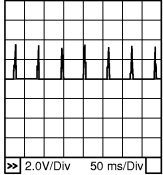
TER-MINAL NO.	WIRE COLOR	ITEM	CONDITION	DATA (DC Voltage)
46 60 61 62	L SB L Y	Ignition signal No. 7 Ignition signal No. 5 Ignition signal No. 3 Ignition signal No. 1	<p>[Engine is running]</p> <ul style="list-style-type: none"> ● Warm-up condition ● Idle speed <p>NOTE: The pulse cycle changes depending on rpm at idle</p>	<p>0 - 0.2V★</p>  <p>PBIB0044E</p>
			<p>[Engine is running]</p> <ul style="list-style-type: none"> ● Warm-up condition ● Engine speed is 2,000 rpm 	<p>0.1 - 0.4V★</p>  <p>PBIB0045E</p>

★: Average voltage for pulse signal (Actual pulse signal can be confirmed by oscilloscope.)

IGNITION SIGNAL

[VK45DE]

EC-IGNSYS-03

— : DETECTABLE LINE FOR DTC
 - - - : NON-DETECTABLE LINE FOR DTC

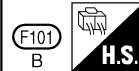
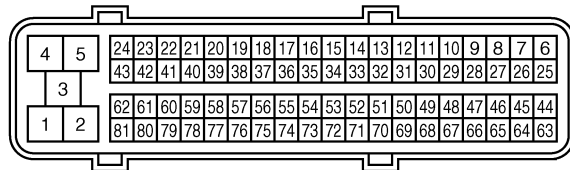
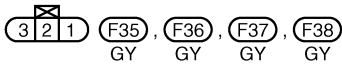
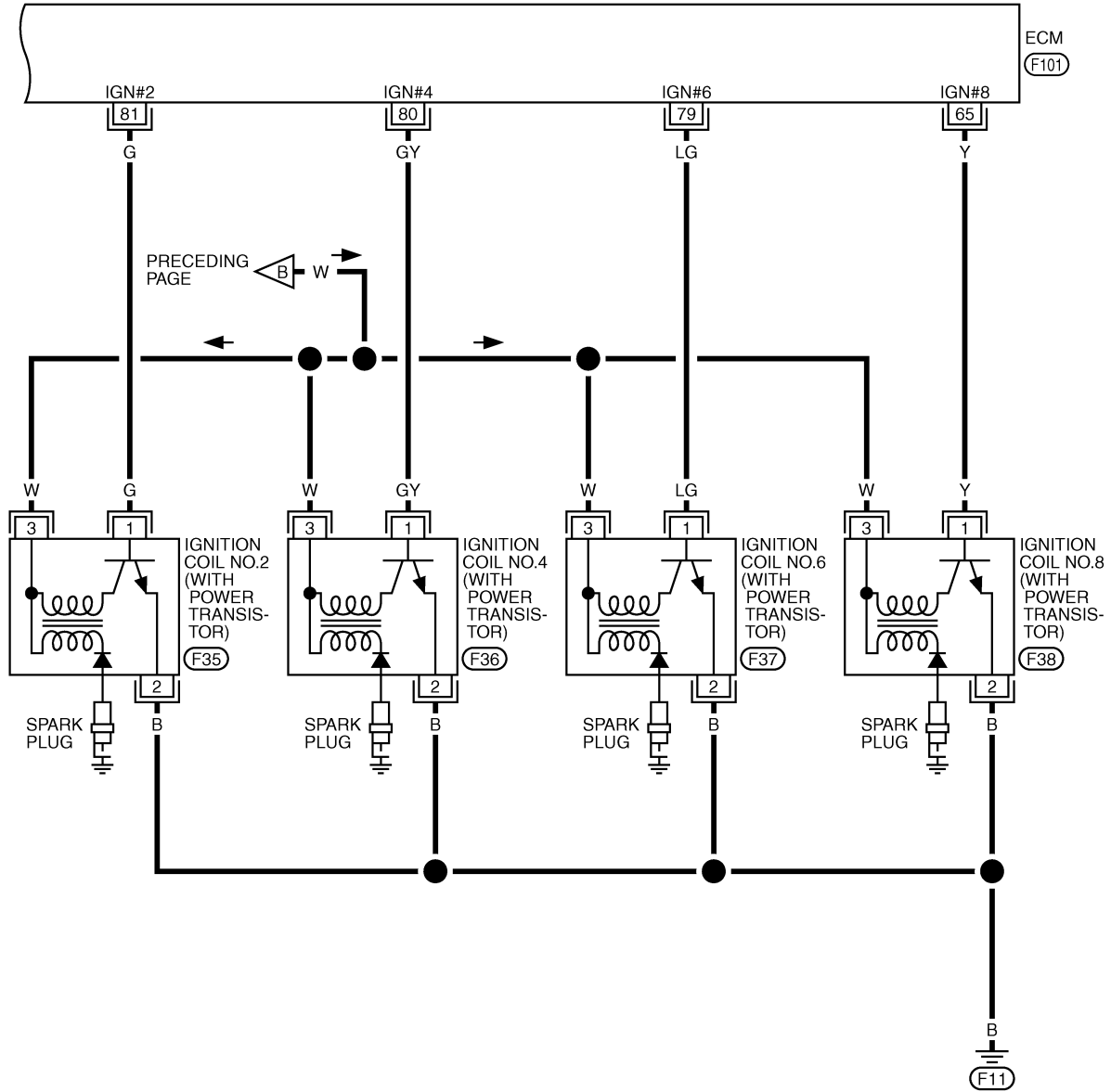

TBWM0263E

IGNITION SIGNAL

[VK45DE]

Specification data are reference values and are measured between each terminal and ground.
Pulse signal is measured by CONSULT-II.

CAUTION:

Do not use ECM ground terminals when measuring input/output voltage. Doing so may result in damage to the ECM's transistor. Use a ground other than ECM terminals, such as the ground.

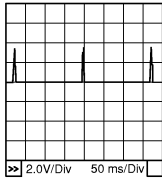
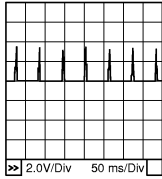
TER-MINAL NO.	WIRE COLOR	ITEM	CONDITION	DATA (DC Voltage)
65 79 80 81	Y LG GY G	Ignition signal No. 8 Ignition signal No. 6 Ignition signal No. 4 Ignition signal No. 2	<p>[Engine is running]</p> <ul style="list-style-type: none"> ● Warm-up condition ● Idle speed <p>NOTE: The pulse cycle changes depending on rpm at idle</p>	<p>0 - 0.2V★</p>  <p>PBIB0044E</p>
			<p>[Engine is running]</p> <ul style="list-style-type: none"> ● Warm-up condition ● Engine speed is 2,000 rpm 	<p>0.1 - 0.4V★</p>  <p>PBIB0045E</p>

★: Average voltage for pulse signal (Actual pulse signal can be confirmed by oscilloscope.)

Diagnostic Procedure

ABS00CEL

1. CHECK ENGINE START

Turn ignition switch OFF, and restart engine.

Is engine running?

Yes or No

- Yes (With CONSULT-II)>>GO TO 2.
- Yes (Without CONSULT-II)>>GO TO 3.
- No >> GO TO 4.

2. CHECK OVERALL FUNCTION

④ **With CONSULT-II**

- Perform "POWER BALANCE" in "ACTIVE TEST" mode with CONSULT-II.
- Make sure that each circuit produces a momentary engine speed drop.

OK or NG

- OK >> **INSPECTION END**
- NG >> GO TO 10.

ACTIVE TEST	
POWER BALANCE	
MONITOR	
ENG SPEED	XXX rpm
MAS A/F SE-B1	XXX V

PBIB0133E

3. CHECK OVERALL FUNCTION

⊗ **Without CONSULT-II**

1. Let engine idle.
2. Read the voltage signal between ECM terminals 46, 60, 61, 62, 65, 79, 80, 81 and ground with an oscilloscope.
3. Verify that the oscilloscope screen shows the signal wave as shown below.

NOTE:

The pulse cycle changes depending on rpm at idle.

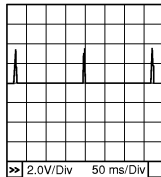

PBIB0044E

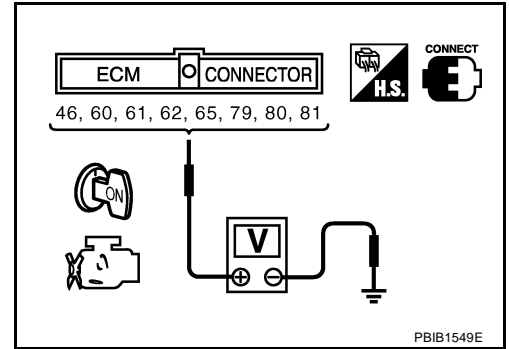

PBIB1549E

OK or NG

- OK >> **INSPECTION END**
 NG >> GO TO 10.

4. CHECK IGNITION COIL POWER SUPPLY CIRCUIT-I

1. Turn ignition switch OFF, wait at least 10 seconds and then turn ON.
2. Check voltage between ECM terminals 119, 120 and ground with CONSULT-II or tester.

Voltage: Battery voltage

OK or NG

- OK >> GO TO 5.
 NG >> Go to [EC-785. "POWER SUPPLY AND GROUND CIRCUIT"](#).

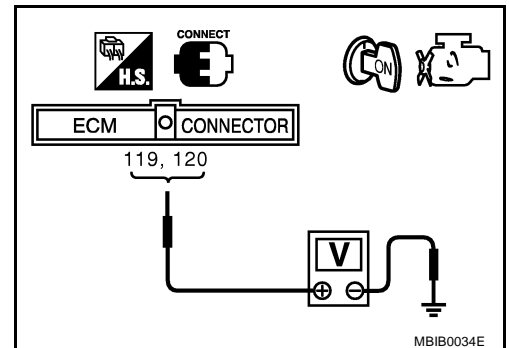

MBIB0034E

5. CHECK IGNITION COIL POWER SUPPLY CIRCUIT-II

1. Turn ignition switch OFF.
2. Disconnect condenser harness connector.
3. Turn ignition switch ON.

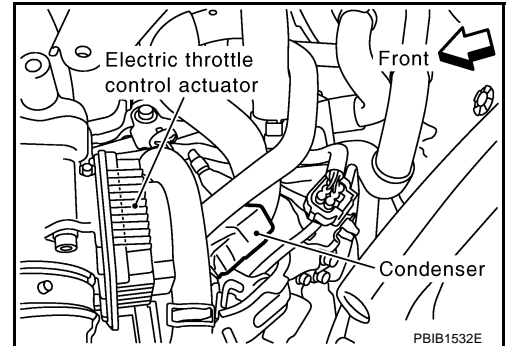

4. Check voltage between condenser terminal 1 and ground with CONSULT-II or tester.

Voltage: Battery voltage

OK or NG

- OK >> GO TO 8.
 NG >> GO TO 6.

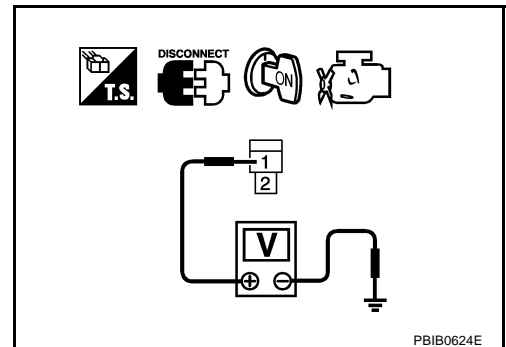

6. CHECK IGNITION COIL POWER SUPPLY CIRCUIT-III

1. Turn ignition switch OFF.
2. Disconnect IPDM E/R harness connector E7.
3. Check harness continuity between IPDM E/R terminal 17 and condenser terminal 1. Refer to Wiring Diagram.

Continuity should exist.

4. Also check harness for short to ground and short to power.

OK or NG

- OK >> Go to [EC-785. "POWER SUPPLY AND GROUND CIRCUIT"](#) .
 NG >> GO TO 7.

7. DETECT MALFUNCTIONING PART

Check the following.

- Harness connector E19, F49
- Harness for open or short between IPDM E/R and condenser

>> Repair open circuit or short to ground or short to power in harness or connectors.

8. CHECK CONDENSER GROUND CIRCUIT FOR OPEN AND SHORT

1. Turn ignition switch OFF.
2. Check harness continuity between condenser terminal 2 and ground.
Refer to Wiring Diagram.

Continuity should exist.

3. Also check harness for short to power.

OK or NG

OK >> GO TO 9.

NG >> Repair open circuit or short to power in harness or connectors.

9. CHECK CONDENSER

Refer to [EC-1272, "Component Inspection"](#) .

OK or NG

OK >> GO TO 10.

NG >> Replace condenser.

10. CHECK IGNITION COIL POWER SUPPLY CIRCUIT-IV

1. Turn ignition switch OFF.
2. Reconnect all harness connectors disconnected.
3. Disconnect ignition coil harness connector.

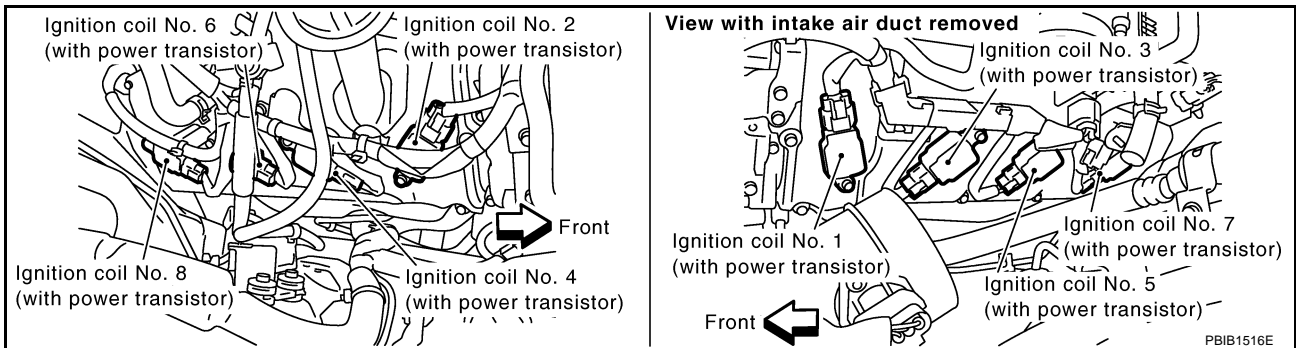

4. Turn ignition switch ON.
5. Check voltage between ignition coil terminal 3 and ground with CONSULT-II or tester.

Voltage: Battery voltage

OK or NG

OK >> GO TO 12.

NG >> GO TO 11.

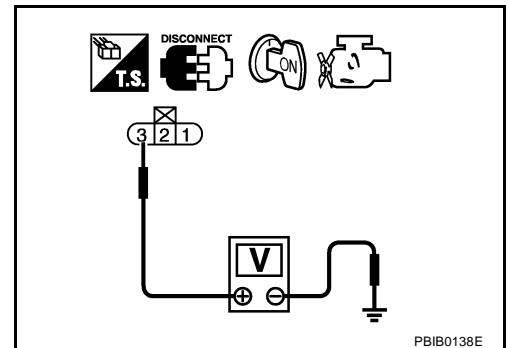

11. DETECT MALFUNCTIONING PART

Check the following.

- Harness connector F49
- Harness for open or short between ignition coil and harness connector F49

>> Repair or replace harness or connectors.

12. CHECK IGNITION COIL GROUND CIRCUIT FOR OPEN AND SHORT

1. Turn ignition switch OFF.
2. Check harness continuity between ignition coil terminal 2 and ground.
Refer to Wiring Diagram.

Continuity should exist.

3. Also check harness for short to power.

OK or NG

OK >> GO TO 13.

NG >> Repair open circuit or short to power in harness or connectors.

13. CHECK IGNITION COIL OUTPUT SIGNAL CIRCUIT FOR OPEN AND SHORT

1. Disconnect ECM harness connector.
2. Check harness continuity between ECM terminals 46, 60, 61, 62, 65, 79, 80, 81 and ignition coil terminal 1.
Refer to Wiring Diagram.

Continuity should exist.

3. Also check harness for short to ground and short to power.

OK or NG

OK >> GO TO 14.

NG >> Repair open circuit or short to ground or short to power in harness or connectors.

14. CHECK IGNITION COIL WITH POWER TRANSISTOR

Refer to [EC-1272, "Component Inspection"](#) .

OK or NG

OK >> GO TO 15.

NG >> Replace ignition coil with power transistor.

15. CHECK INTERMITTENT INCIDENT

Refer to [EC-784, "TROUBLE DIAGNOSIS FOR INTERMITTENT INCIDENT"](#) .

>> INSPECTION END

Component Inspection IGNITION COIL WITH POWER TRANSISTOR

ABS00CEM

1. Turn ignition switch OFF.
2. Disconnect ignition coil harness connector.
3. Check resistance between ignition coil terminals as follows.

Terminal No. (Polarity)	Resistance Ω [at 25°C (77°F)]
1 and 2	Except 0 or ∞
1 and 3	Except 0
2 and 3	

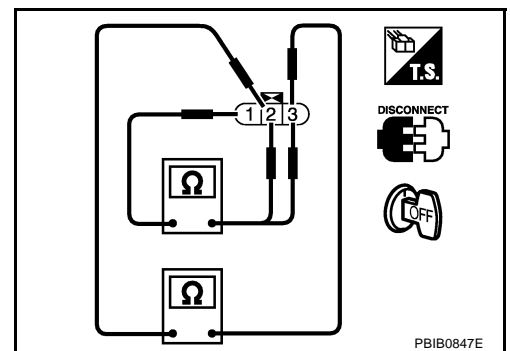

CONDENSER

1. Turn ignition switch OFF.
2. Disconnect condenser harness connector.

IGNITION SIGNAL

[VK45DE]

3. Check resistance between condenser terminals 1 and 2.

Resistance	Above 1 M Ω at 25°C (77°F)
------------	-----------------------------------

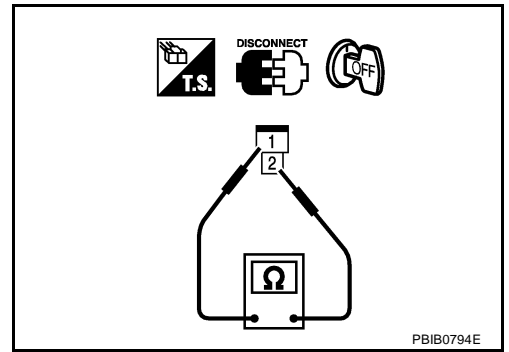

ABS00CEN

Removal and Installation IGNITION COIL WITH POWER TRANSISTOR

Refer to [EM-185, "IGNITION COIL"](#) .

A
EC
C
D
E
F
G
H
I
J
K
L
M

INJECTOR CIRCUIT

PFP:16600

Component Description

ABS00CEO

The fuel injector is a small, precise solenoid valve. When the ECM supplies a ground to the injector circuit, the coil in the injector is energized. The energized coil pulls the ball valve back and allows fuel to flow through the injector into the intake manifold. The amount of fuel injected depends upon the injection pulse duration. Pulse duration is the length of time the injector remains open. The ECM controls the injection pulse duration based on engine fuel needs.

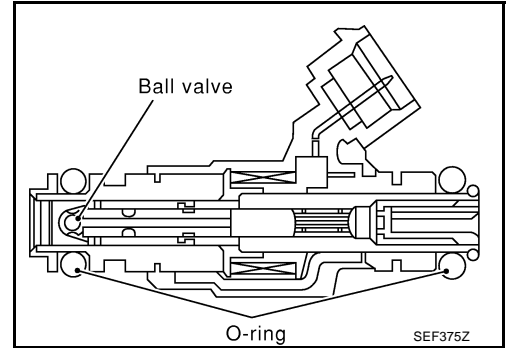

CONSULT-II Reference Value in Data Monitor Mode

ABS00CEP

Specification data are reference values.

MONITOR ITEM	CONDITION	SPECIFICATION
B/FUEL SCHDL	See EC-780. "TROUBLE DIAGNOSIS - SPECIFICATION VALUE" .	
INJ PULSE-B1 INJ PULSE-B2	<ul style="list-style-type: none"> ● Engine: After warming up ● Air conditioner switch: OFF 	Idle 2.3 - 2.9 msec
	<ul style="list-style-type: none"> ● Shift lever: N ● No load 	2,000 rpm 2.3 - 2.9 msec

INJECTOR CIRCUIT

[VK45DE]

Wiring Diagram

ABS00CEQ

EC-INJECT-01

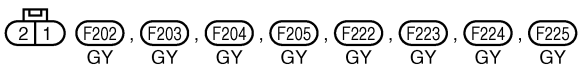
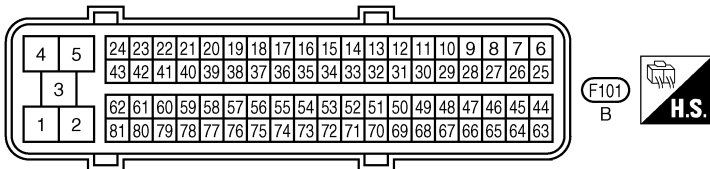
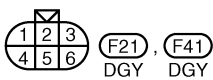
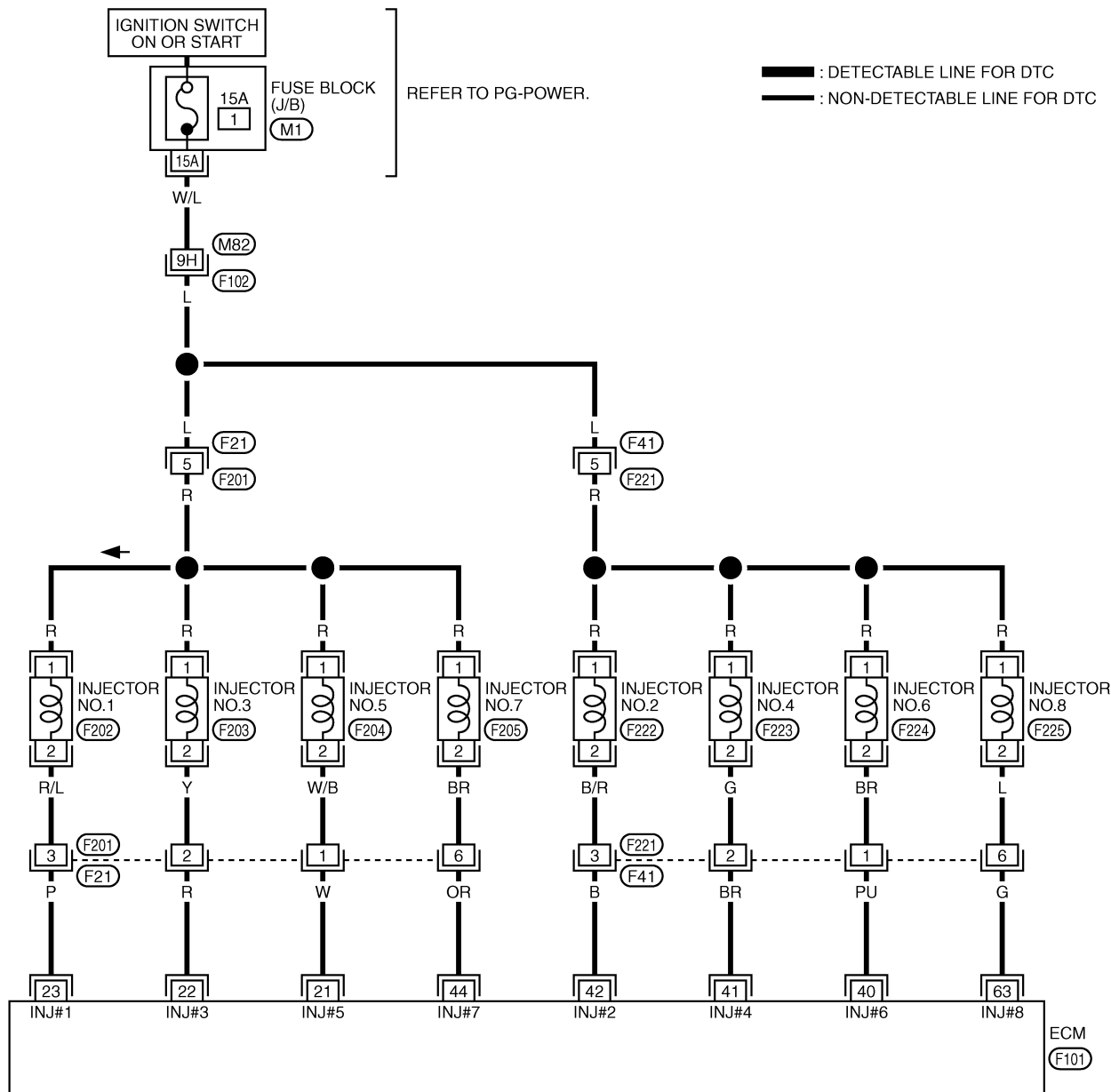

REFER TO THE FOLLOWING.

(F102) -SUPER MULTIPLE JUNCTION (SMJ)

(M1) -FUSE BLOCK-JUNCTION BOX (J/B)

TBWM0264E

INJECTOR CIRCUIT

[VK45DE]

Specification data are reference values and are measured between each terminal and ground.
Pulse signal is measured by CONSULT-II.

CAUTION:

Do not use ECM ground terminals when measuring input/output voltage. Doing so may result in damage to the ECM's transistor. Use a ground other than ECM terminals, such as the ground.

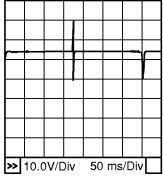
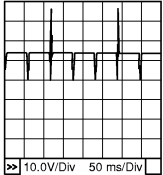
TER-MINAL NO.	WIRE COLOR	ITEM	CONDITION	DATA (DC Voltage)	
21	W	Injector No. 5	<p>[Engine is running]</p> <ul style="list-style-type: none"> ● Warm-up condition ● Idle speed <p>NOTE: The pulse cycle changes depending on rpm at idle</p>	<p>BATTERY VOLTAGE (11 - 14V)★</p>  <p>PBIB0042E</p>	
22	R	Injector No. 3		<p>[Engine is running]</p> <ul style="list-style-type: none"> ● Warm-up condition ● Engine speed is 2,000 rpm 	<p>BATTERY VOLTAGE (11 - 14V)★</p>  <p>PBIB0043E</p>
23	P	Injector No. 1			
40	PU	Injector No. 6			
41	BR	Injector No. 4			
42	B	Injector No. 2			
44	OR	Injector No. 7			
63	G	Injector No. 8			

★: Average voltage for pulse signal (Actual pulse signal can be confirmed by oscilloscope.)

Diagnostic Procedure

ABS00CER

1. INSPECTION START

Turn ignition switch to START.

Is any cylinder ignited?

Yes or No

- Yes >> GO TO 2.
- No >> GO TO 3.

2. CHECK OVERALL FUNCTION

④ With CONSULT-II

1. Start engine.
2. Perform "POWER BALANCE" in "ACTIVE TEST" mode with CONSULT-II.
3. Make sure that each circuit produces a momentary engine speed drop.

ACTIVE TEST	
POWER BALANCE	
MONITOR	
ENG SPEED	XXX rpm
MAS A/F SE-B1	XXX V

PBIB0133E

⊗ Without CONSULT-II

1. Start engine.
2. Listen to each injector operating sound.
Clicking noise should be heard.

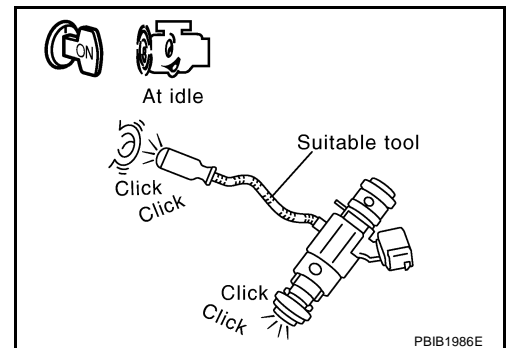

OK or NG

- OK >> **INSPECTION END**
 NG >> **GO TO 3.**

A
EC
C
D
E
F
G
H
I
J
K
L
M

3. CHECK INJECTOR POWER SUPPLY CIRCUIT

1. Turn ignition switch OFF.
2. Disconnect injector harness connector.

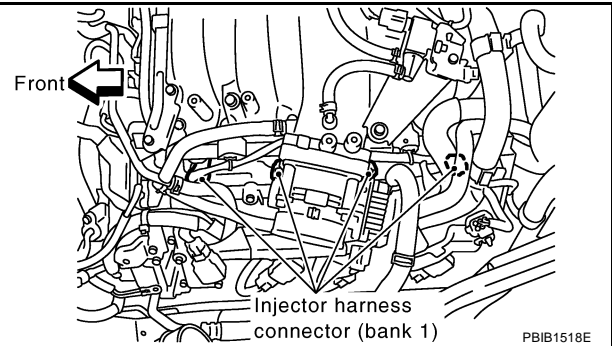
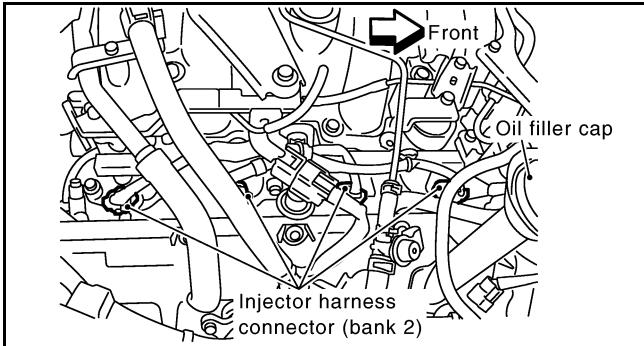

3. Turn ignition switch ON.
4. Check voltage between injector terminal 1 and ground with CONSULT-II or tester.

Voltage: Battery voltage

OK or NG

- OK >> GO TO 5.
- NG >> GO TO 4.

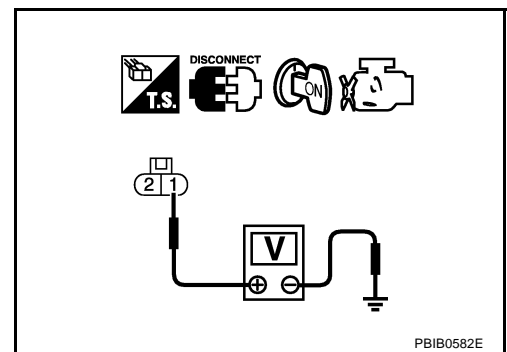

4. DETECT MALFUNCTIONING PART

Check the following.

- Harness connectors M82, F102
- Harness connectors F21, F201
- Harness connectors F41, F221
- Fuse block (J/B) connector M1
- 15A fuse
- Harness for open or short between injector and fuse

>> Repair open circuit or short to ground or short to power in harness or connectors.

5. CHECK INJECTOR OUTPUT SIGNAL CIRCUIT FOR OPEN AND SHORT

1. Turn ignition switch OFF.
2. Disconnect ECM harness connector.
3. Check harness continuity between injector terminal 2 and ECM terminals 21, 22, 23, 40, 41, 42, 44, 63. Refer to Wiring Diagram.

Continuity should exist.

4. Also check harness for short to ground and short to power.

OK or NG

- OK >> GO TO 7.
- NG >> GO TO 6.

6. DETECT MALFUNCTIONING PART

Check the following.

- Harness connectors F21, F201
- Harness connectors F41, F221
- Harness for open or short between injector and ECM

>> Repair open circuit or short to ground or short to power in harness or connectors.

7. CHECK INJECTOR

Refer to [EC-1279, "Component Inspection"](#) .

OK or NG

- OK >> GO TO 8.
 NG >> Replace injector.

8. CHECK INTERMITTENT INCIDENT

Refer to [EC-784, "TROUBLE DIAGNOSIS FOR INTERMITTENT INCIDENT"](#) .

>> INSPECTION END

Component Inspection INJECTOR

1. Disconnect injector harness connector.
2. Check resistance between terminals as shown in the figure.

Resistance: 13.5 - 17.5Ω [at 10 - 60°C (50 - 140°F)]

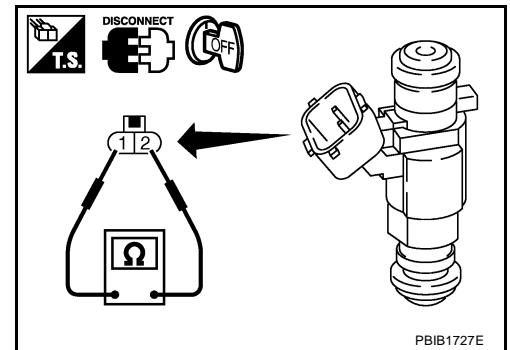

Removal and Installation INJECTOR

Refer to [EM-188, "FUEL INJECTOR AND FUEL TUBE"](#) .

FUEL PUMP CIRCUIT

[VK45DE]

FUEL PUMP CIRCUIT

PFP:17042

Description SYSTEM DESCRIPTION

ABS00CEU

Sensor	Input signal to ECM	ECM Function	Actuator
Crankshaft position sensor (POS) Camshaft position sensor (PHASE)	Engine speed*	Fuel pump control	Fuel pump relay
Battery	Battery voltage*		

*: ECM determines the start signal status by the signals of engine speed and battery voltage.

The ECM activates the fuel pump for several seconds after the ignition switch is turned ON to improve engine startability. If the ECM receives a engine speed signal from the camshaft position sensor (PHASE), it knows that the engine is rotating, and causes the pump to operate. If the engine speed signal is not received when the ignition switch is ON, the engine stalls. The ECM stops pump operation and prevents battery discharging, thereby improving safety. The ECM does not directly drive the fuel pump. It controls the ON/OFF fuel pump relay, which in turn controls the fuel pump.

Condition	Fuel pump operation
Ignition switch is turned to ON	Operates for 1 second.
Engine running and cranking	Operates.
When engine is stopped	Stops in 1.5 seconds.
Except as shown above	Stops.

COMPONENT DESCRIPTION

A turbine type design fuel pump is used in the fuel tank.

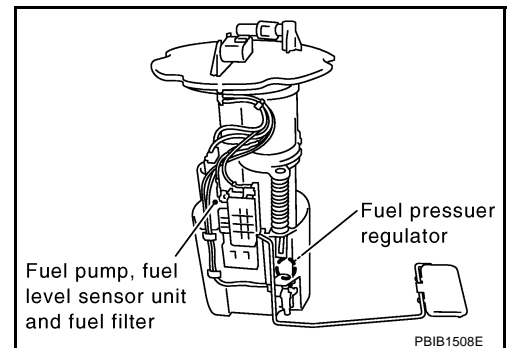

CONSULT-II Reference Value in Data Monitor Mode

ABS00CEV

Specification data are reference values.

MONITOR ITEM	CONDITION	SPECIFICATION
FUEL PUMP RLY	<ul style="list-style-type: none"> ● For 1 second after turning ignition switch ON ● Engine running or cranking 	ON
	<ul style="list-style-type: none"> ● Except above conditions 	OFF

FUEL PUMP CIRCUIT

[VK45DE]

Wiring Diagram

ABS00CEW

EC-F/PUMP-01

: DETECTABLE LINE FOR DTC
 : NON-DETECTABLE LINE FOR DTC

REFER TO PG-POWER.

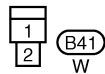
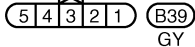
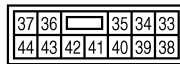
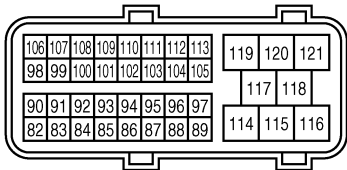
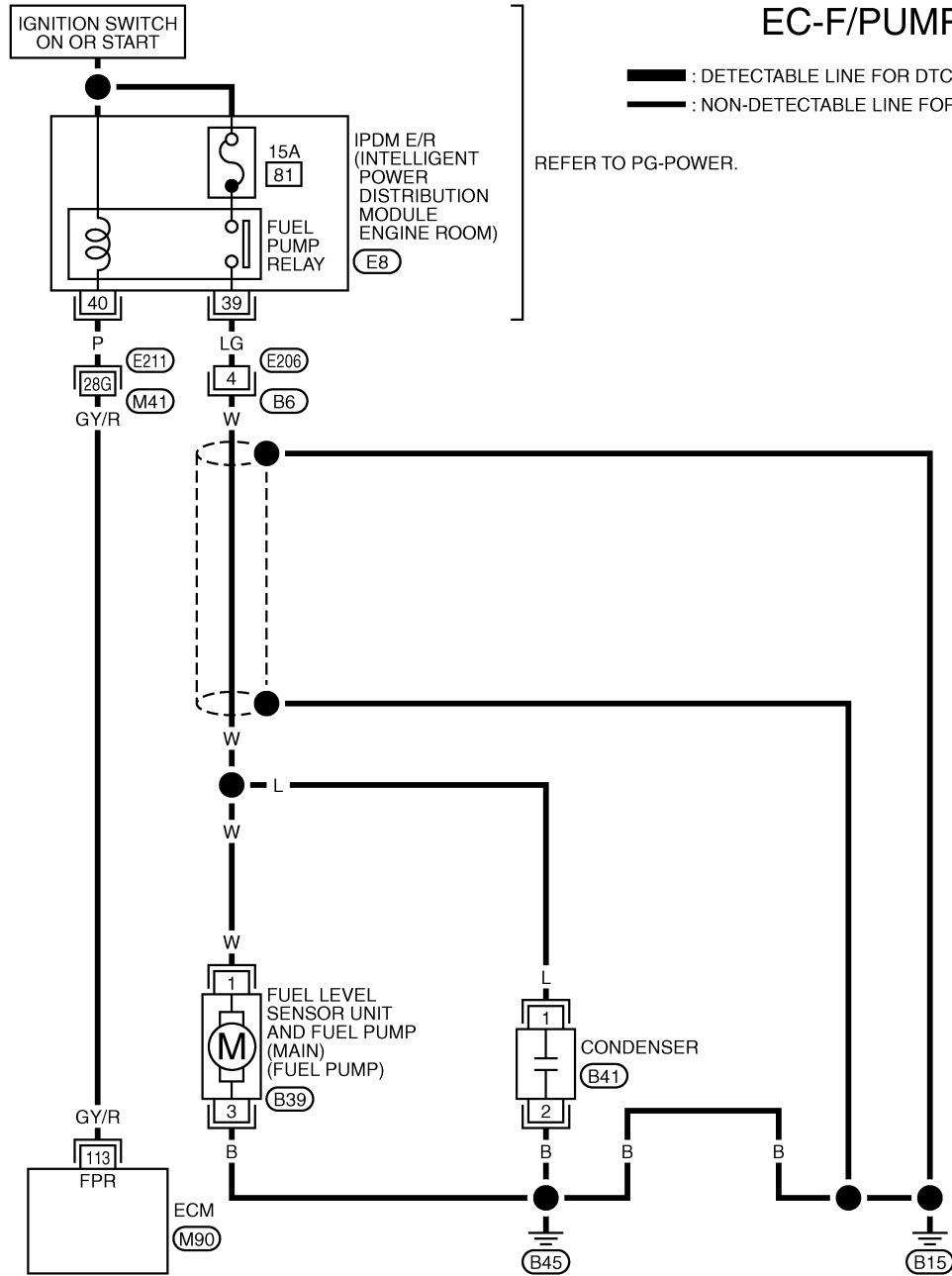

REFER TO THE FOLLOWING.

(E211) -SUPER MULTIPLE JUNCTION (SMJ)

TBWH0112E

FUEL PUMP CIRCUIT

[VK45DE]

Specification data are reference values and are measured between each terminal and ground.

CAUTION:

Do not use ECM ground terminals when measuring input/output voltage. Doing so may result in damage to the ECM's transistor. Use a ground other than ECM terminals, such as the ground.

TER-MINAL NO.	WIRE COLOR	ITEM	CONDITION	DATA (DC Voltage)
113	GY/R	Fuel pump relay	[Ignition switch: ON] ● For 1 second after turning ignition switch ON	0 - 1.5V
			[Engine is running] [Ignition switch: ON] ● More than 1 second after turning ignition switch ON	BATTERY VOLTAGE (11 - 14V)

Diagnostic Procedure

ABS00CEX

1. CHECK OVERALL FUNCTION

- Turn ignition switch ON.
- Pinch fuel feed hose with two fingers.
Fuel pressure pulsation should be felt on the fuel feed hose for 1 second after ignition switch is turned ON.

OK or NG

- OK >> **INSPECTION END**
NG >> GO TO 2.

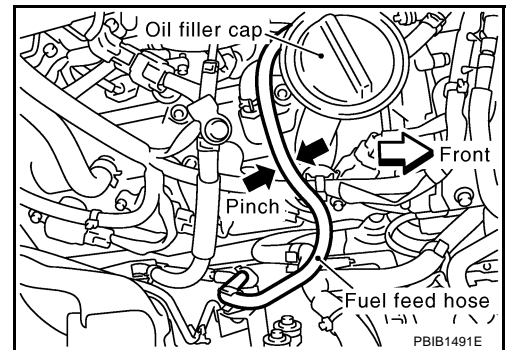

2. CHECK FUEL PUMP POWER SUPPLY CIRCUIT-I

- Turn ignition switch OFF.
- Disconnect ECM harness connector.
- Turn ignition switch ON.
- Check voltage between ECM terminal 113 and ground with CONSULT-II or tester.

Voltage: Battery voltage

OK or NG

- OK >> GO TO 5.
NG >> GO TO 3.

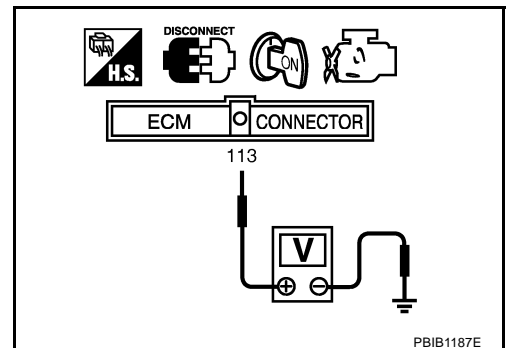

3. CHECK FUEL PUMP POWER SUPPLY CIRCUIT-II

1. Turn ignition switch OFF.
2. Disconnect IPDM E/R harness connector E8.
3. Turn ignition switch ON.
4. Check voltage between IPDM E/R terminal 40 and ground with CONSULT-II or tester.

Voltage: Battery voltage

OK or NG

- OK >> GO TO 4.
- NG >> GO TO 14.

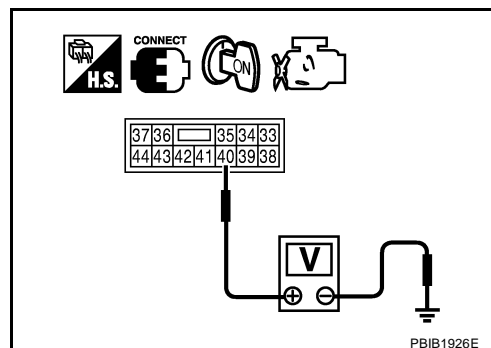

4. DETECT MALFUNCTIONING PART

Check the following.

- Harness connectors E211, M41
- Harness for open or short between IPDM E/R and ECM

>> Repair open circuit or short to ground or short to power in harness or connectors.

5. CHECK CONDENSER POWER SUPPLY CIRCUIT-I

1. Turn ignition switch OFF.
2. Reconnect all harness connectors disconnected.
3. Disconnect condenser harness connector.
4. Turn ignition switch ON.

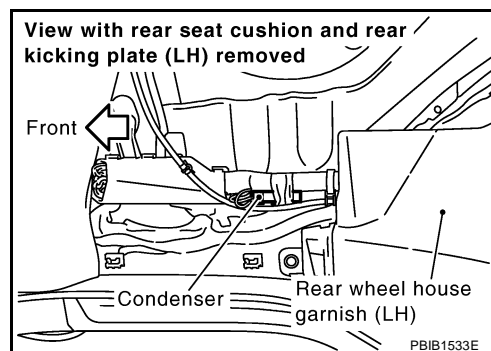

5. Check voltage between condenser terminal 1 and ground with CONSULT-II or tester.

Voltage: Battery voltage should exist for 1 second after ignition switch is turned ON.

6. Also check harness for short to ground and short to power.

OK or NG

- OK >> GO TO 9.
- NG >> GO TO 6.

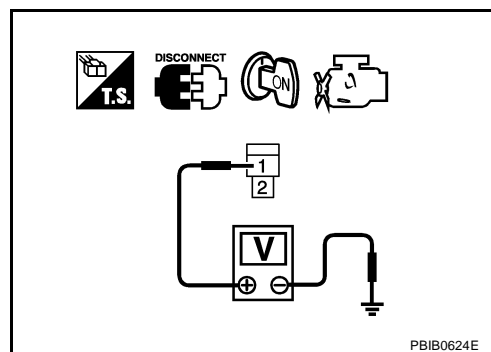

6. CHECK 15A FUSE

1. Turn ignition switch OFF.
2. Disconnect 15A fuse.
3. Check 15A fuse.

OK or NG

- OK >> GO TO 7.
 NG >> Replace fuse.

7. CHECK CONDENSER POWER SUPPLY CIRCUIT-II

1. Disconnect IPDM E/R harness connector E8.
2. Check harness continuity between IPDM E/R terminal 39 and condenser terminal 1.
 Refer to Wiring Diagram.

Continuity should exist.

3. Also check harness for short to ground and short to power.

OK or NG

- OK >> GO TO 14.
 NG >> GO TO 8.

8. DETECT MALFUNCTIONING PART

Check the following.

- Harness connectors E206, B6
- Harness for open or short between IPDM E/R and condenser

>> Repair harness or connectors.

9. CHECK CONDENSER GROUND CIRCUIT FOR OPEN AND SHORT

1. Check harness continuity between condenser terminal 2 and ground.
 Refer to Wiring Diagram.

Continuity should exist.

2. Also check harness for short to power.

OK or NG

- OK >> GO TO 10.
 NG >> Repair open circuit or short to power in harness or connectors.

10. CHECK CONDENSER

Refer to [EC-1285, "Component Inspection"](#) .

OK or NG

- OK >> GO TO 11.
 NG >> Replace condenser.

11. CHECK FUEL PUMP POWER SUPPLY AND GROUND CIRCUIT FOR OPEN AND SHORT

1. Turn ignition switch OFF.
2. Disconnect "fuel level sensor unit and fuel pump" harness connector.
3. Disconnect harness connector E206, B6.
4. Check harness continuity between "fuel level sensor unit and fuel pump" terminal 1 and harness connector B6 terminal 4, "fuel level sensor unit and fuel pump" terminal 3 and ground. Refer to Wiring Diagram.

Continuity should exist.

5. Also check harness for short to ground and short to power.

OK or NG

- OK >> GO TO 13.
 NG >> GO TO 12.

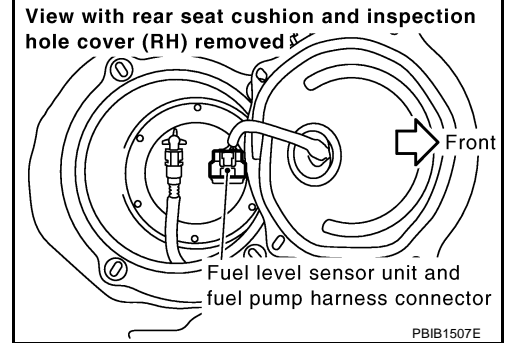

12. DETECT MALFUNCTIONING PART

Check the following.

- Harness connector B6
- Harness for open or short between "fuel level sensor unit and fuel pump" and harness connector B6
- Harness for open or short between "fuel level sensor unit and fuel pump" and ground

>> Repair open circuit or short to ground or short to power in harness or connectors.

13. CHECK FUEL PUMP

Refer to [EC-1285, "Component Inspection"](#).

OK or NG

- OK >> GO TO 14.
 NG >> Replace fuel pump.

14. CHECK INTERMITTENT INCIDENT

Refer to [EC-784, "TROUBLE DIAGNOSIS FOR INTERMITTENT INCIDENT"](#).

OK or NG

- OK >> Replace IPDM E/R.
 NG >> Repair or replace harness or connectors.

Component Inspection FUEL PUMP

ABS00CEY

1. Disconnect "fuel level sensor unit and fuel pump" harness connector.
2. Check resistance between "fuel level sensor unit and fuel pump" terminals 1 and 3.

Resistance: Approximately 0.2 - 5.0Ω [at 25°C (77°F)]

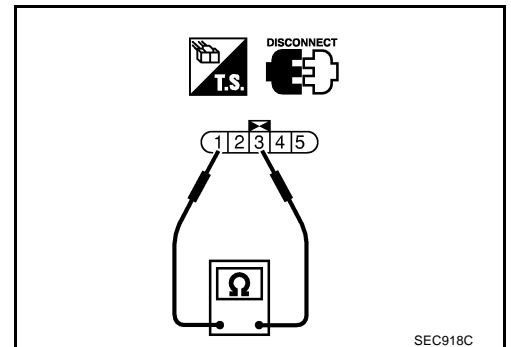

FUEL PUMP CIRCUIT

[VK45DE]

CONDENSER

1. Turn ignition switch OFF.
2. Disconnect condenser harness connector.
3. Check resistance between condenser terminals as 1 and 2.

Resistance	Above 1 MΩ at 25°C (77°F)
------------	---------------------------

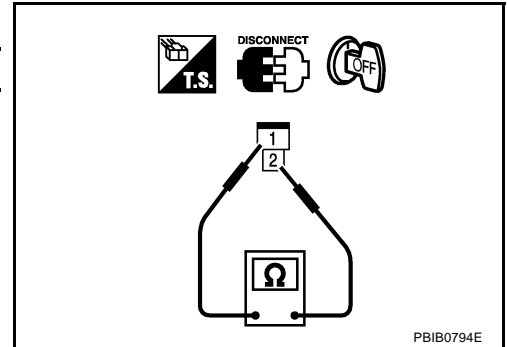

Removal and Installation FUEL PUMP

Refer to [FL-4, "FUEL LEVEL SENSOR UNIT, FUEL FILTER AND FUEL PUMP ASSEMBLY"](#) .

ABS00CEZ

REFRIGERANT PRESSURE SENSOR

[VK45DE]

REFRIGERANT PRESSURE SENSOR

PF9:92136

Component Description

ABS00CF0

The refrigerant pressure sensor is installed at the condenser of the air conditioner system. The sensor uses an electrostatic volume pressure transducer to convert refrigerant pressure to voltage. The voltage signal is sent to ECM, and ECM controls cooling fan system.

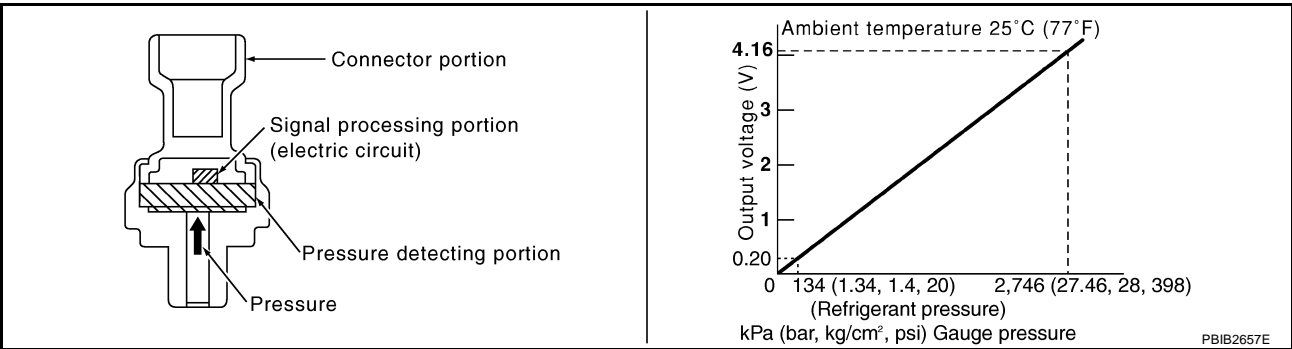
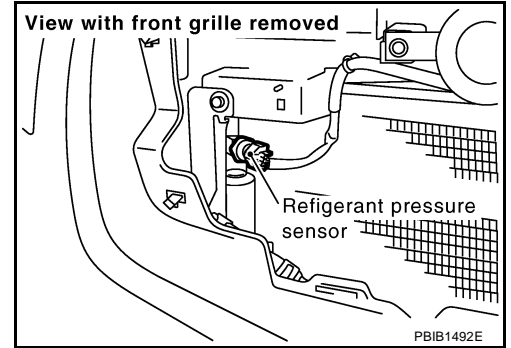

REFRIGERANT PRESSURE SENSOR

[VK45DE]

Wiring Diagram

ABS00CF1

EC-RP/SEN-01

: DETECTABLE LINE FOR DTC
 : NON-DETECTABLE LINE FOR DTC

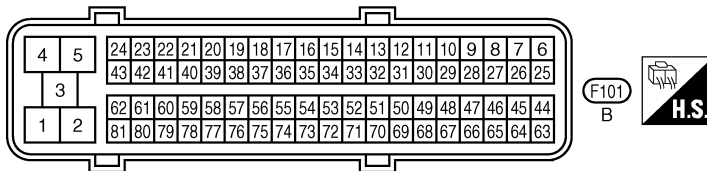
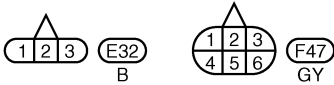
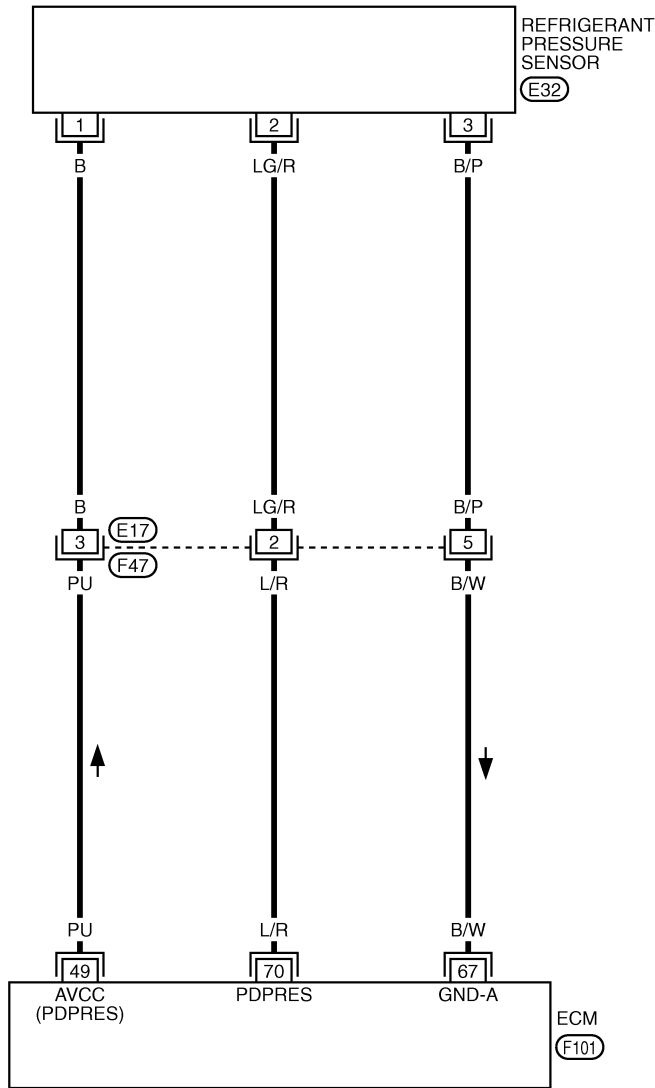

TBWM0265E

REFRIGERANT PRESSURE SENSOR

[VK45DE]

Specification data are reference values and are measured between each terminal and ground.

CAUTION:

Do not use ECM ground terminals when measuring input/output voltage. Doing so may result in damage to the ECM's transistor. Use a ground other than ECM terminals, such as the ground.

TER-MINAL NO.	WIRE COLOR	ITEM	CONDITION	DATA (DC Voltage)
49	PU	Sensor power supply (Refrigerant pressure sensor)	[Ignition switch: ON]	Approximately 5V
67	B/W	Sensor ground (Mass air flow sensor / IAT sensor / Power steering pressure sensor / EVAP control system pressure sensor / Refrigerant pressure sensor / ECT sensor)	[Engine is running] ● Warm-up condition ● Idle speed	Approximately 0V
70	L/R	Refrigerant pressure sensor	[Engine is running] ● Warm-up condition ● Both A/C switch and blower switch are ON (Compressor operates)	1.0 - 4.0V

Diagnostic Procedure

ABS00CF2

1. CHECK REFRIGERANT PRESSURE SENSOR OVERALL FUNCTION

1. Start engine and warm it up to normal operating temperature.
2. Turn A/C switch and blower switch ON.
3. Check voltage between ECM terminal 70 and ground with CONSULT-II or tester.

Voltage: 1.0 - 4.0V

OK or NG

- OK >> **INSPECTION END**
- NG >> GO TO 2.

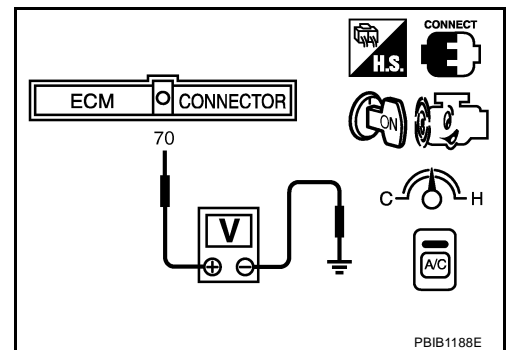

2. CHECK GROUND CONNECTIONS

1. Turn A/C switch and blower switch OFF.
2. Turn ignition switch OFF.
3. Loosen and retighten three ground screws on the body.
Refer to [EC-791, "Ground Inspection"](#).

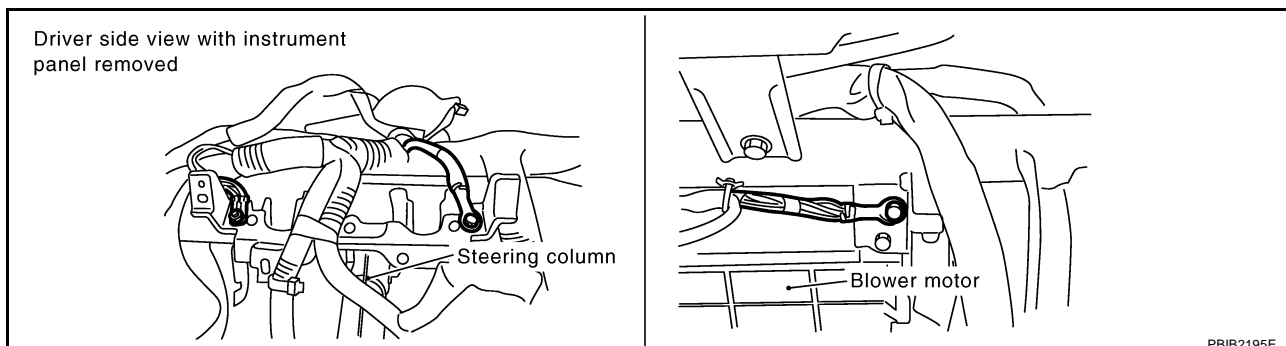

OK or NG

- OK >> GO TO 3.
NG >> Repair or replace ground connections.

3. CHECK REFRIGERANT PRESSURE SENSOR POWER SUPPLY CIRCUIT

1. Disconnect refrigerant pressure sensor harness connector.
2. Turn ignition switch ON.

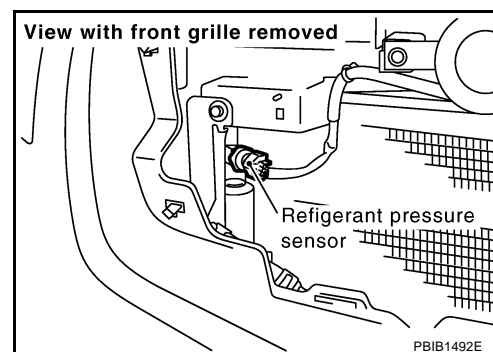

3. Check voltage between refrigerant pressure sensor terminal 1 and ground with CONSULT-II or tester.

Voltage: Approximately 5V

OK or NG

- OK >> GO TO 5.
NG >> GO TO 4.

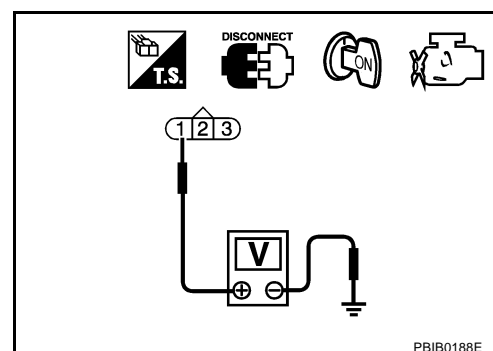

4. DETECT MALFUNCTIONING PART

Check the following.

- Harness connectors E17, F47
- Harness for open or short between ECM and refrigerant pressure sensor

>> Repair open circuit or short to ground or short to power in harness or connectors.

5. CHECK REFRIGERANT PRESSURE SENSOR GROUND CIRCUIT FOR OPEN AND SHORT

1. Turn ignition switch OFF.
2. Disconnect ECM harness connector.
3. Check harness continuity between refrigerant pressure sensor terminal 3 and ECM terminal 67.
Refer to Wiring Diagram.

Continuity should exist.

4. Also check harness for short to ground and short to power.

OK or NG

- OK >> GO TO 7.
NG >> GO TO 6.

6. DETECT MALFUNCTIONING PART

Check the following.

- Harness connectors E17, F47
- Harness for open or short between ECM and refrigerant pressure sensor

>> Repair open circuit or short to ground or short to power in harness or connectors.

7. CHECK REFRIGERANT PRESSURE SENSOR INPUT SIGNAL CIRCUIT FOR OPEN AND SHORT

1. Check harness continuity between ECM terminal 70 and refrigerant pressure sensor terminal 2.
Refer to Wiring Diagram.

Continuity should exist.

2. Also check harness for short to ground and short to power.

OK or NG

- OK >> GO TO 9.
NG >> GO TO 8.

8. DETECT MALFUNCTIONING PART

Check the following.

- Harness connectors E17, F47
- Harness for open or short between ECM and refrigerant pressure sensor

>> Repair open circuit or short to ground or short to power in harness or connectors.

9. CHECK INTERMITTENT INCIDENT

Refer to [EC-784, "TROUBLE DIAGNOSIS FOR INTERMITTENT INCIDENT"](#) .

OK or NG

- OK >> Replace refrigerant pressure sensor.
NG >> Repair or replace.

Removal and Installation REFRIGERANT PRESSURE SENSOR

ABS00CF3

Refer to [ATC-155, "Removal and Installation of Refrigerant Pressure Sensor"](#) .

ELECTRICAL LOAD SIGNAL

PFP:25350

Description

ABS00CF4

The electrical load signal (Headlamp switch signal, rear window defogger switch signal, etc.) is transferred through the CAN communication line from BCM to ECM via IPDM E/R.

CONSULT-II Reference Value in Data Monitor Mode

ABS00CF5

Specification data are reference values.

MONITOR ITEM	CONDITION	SPECIFICATION
LOAD SIGNAL	● Ignition switch: ON	ON
	Rear window defogger switch is ON and/or lighting switch is in 2nd	ON
	Rear window defogger switch is OFF and lighting switch is OFF	OFF

Diagnostic Procedure

ABS00CF6

1. CHECK LOAD SIGNAL CIRCUIT OVERALL FUNCTION-I

1. Turn ignition switch ON.
2. Connect CONSULT-II and select "DATA MONITOR" mode.
3. Select "LOAD SIGNAL" and check indication under the following conditions.

Condition	Indication
Rear window defogger switch ON	ON
Rear window defogger switch OFF	OFF

OK or NG

- OK >> GO TO 2.
 NG >> GO TO 3.

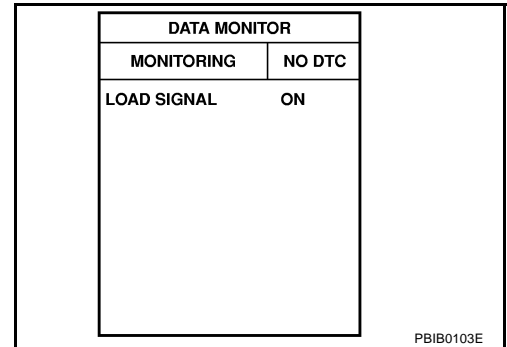

2. CHECK LOAD SIGNAL CIRCUIT OVERALL FUNCTION-II

Check "LOAD SIGNAL" indication under the following conditions.

Condition	Indication
Lighting switch ON at 2nd position	ON
Lighting switch OFF	OFF

OK or NG

- OK >> **INSPECTION END**
 NG >> GO TO 4.

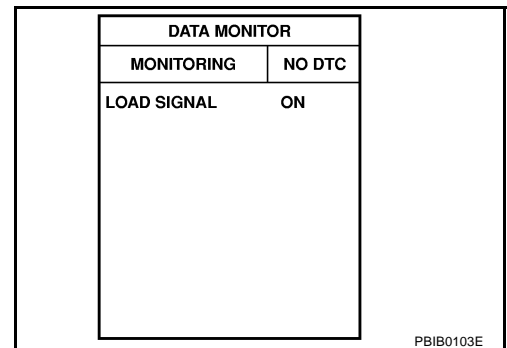

3. CHECK REAR WINDOW DEFOGGER SYSTEM

Refer to [GW-86, "REAR WINDOW DEFOGGER"](#) .

>> **INSPECTION END**

4. CHECK HEADLAMP SYSTEM

Refer to [LT-7, "HEADLAMP - XENON TYPE -"](#) .

>> **INSPECTION END**

ICC BRAKE SWITCH

[VK45DE]

ICC BRAKE SWITCH

PFP:25320

Component Description

ABS00CF7

When depress on the brake pedal, ICC brake switch is turned OFF and stop lamp switch is turned ON. ECM detects the state of the brake pedal by this input of two kinds (ON/OFF signal)
Refer to [ACS-6, "DESCRIPTION"](#) for the ICC function.

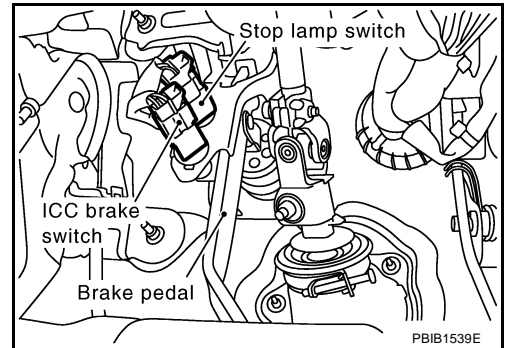

CONSULT-II Reference Value in Data Monitor Mode

ABS00CF8

Specification data are reference values.

MONITOR ITEM	CONDITION		SPECIFICATION
BRAKE SW1 (ICC brake switch)	● Ignition switch: ON	● Brake pedal: Fully released	ON
		● Brake pedal: Slightly depressed	OFF
BRAKE SW2 (stop lamp switch)	● Ignition switch: ON	● Brake pedal: Fully released	OFF
		● Brake pedal: Slightly depressed	ON

ICC BRAKE SWITCH

[VK45DE]

ABS00CF9

Wiring Diagram

EC-ICCB0F-01

— : DETECTABLE LINE FOR DTC
 — : NON-DETECTABLE LINE FOR DTC

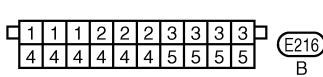
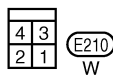
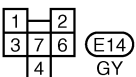
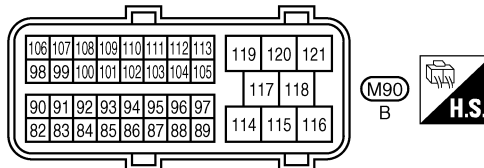
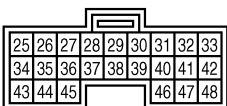
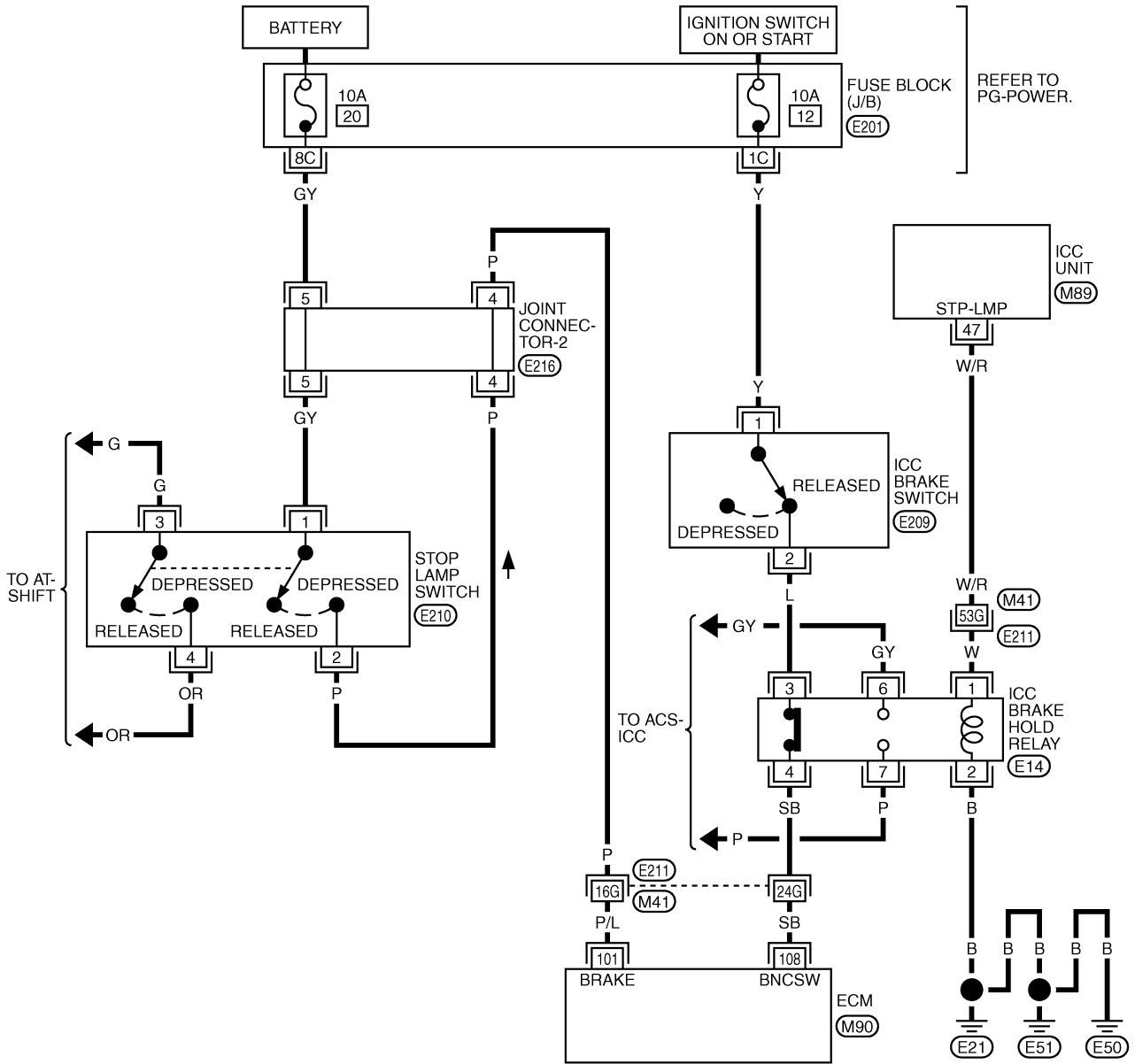

REFER TO THE FOLLOWING.

(E21) -SUPER MULTIPLE JUNCTION (SMJ)

(E201) -FUSE BLOCK-JUNCTION BOX (J/B)

TBWM0275E

ICC BRAKE SWITCH

[VK45DE]

Specification data are reference values and are measured between each terminal and ground.

CAUTION:

Do not use ECM ground terminals when measuring input/output voltage. Doing so may result in damage to the ECM's transistor. Use a ground other than ECM terminals, such as the ground.

TERMI- NAL NO.	WIRE COLOR	ITEM	CONDITION	DATA (DC Voltage)
101	P/L	Stop lamp switch	[Ignition switch: OFF] ● Brake pedal: Fully released	Approximately 0V
			[Ignition switch: OFF] ● Brake pedal: Slightly depressed	BATTERY VOLTAGE (11 - 14V)
108	S/B	ICC brake switch	[Ignition switch: ON] ● Brake pedal: Slightly depressed	Approximately 0V
			[Ignition switch: ON] ● Brake pedal: Fully released	BATTERY VOLTAGE (11 - 14V)

Diagnostic Procedure

ABS00CFA

1. CHECK OVERALL FUNCTION-I

With CONSULT-II

- Turn ignition switch ON.
- Select "BRAKE SW1" in "DATA MONITOR" mode with CONSULT-II.
- Check "BRAKE SW1" indication under the following conditions.

CONDITION	INDICATION
When brake pedal is slightly depress	OFF
When brake pedal is fully released	ON

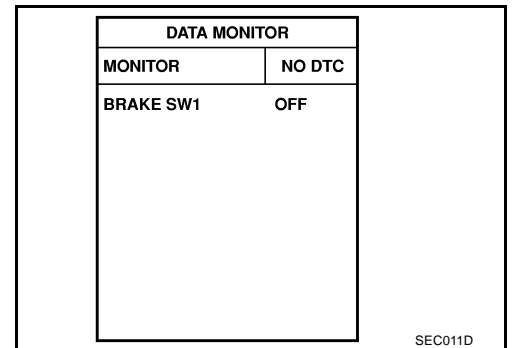

Without CONSULT-II

- Turn ignition switch ON.
- Check voltage between ECM terminal 108 and ground under the following conditions.

CONDITION	VOLTAGE
When brake pedal is slightly depress	Approximately 0V
When brake pedal is fully released	Battery voltage

OK or NG

- OK >> GO TO 2.
NG >> GO TO 3.

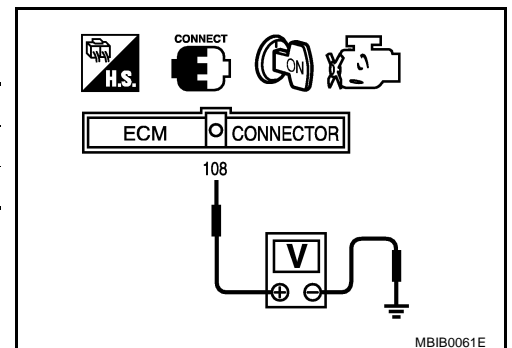

2. CHECK OVERALL FUNCTION-II

With CONSULT-II

Check "BRAKE SW2" indication in "DATA MONITOR" mode.

CONDITION	INDICATION
When brake pedal is fully released	OFF
When brake pedal is slightly depressed	ON

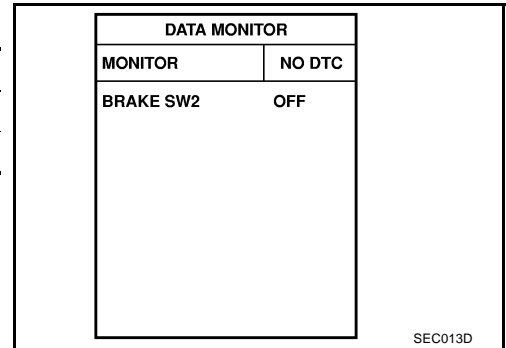

Without CONSULT-II

Check voltage between ECM terminal 101 and ground under the following conditions.

CONDITION	VOLTAGE
When brake pedal is fully released	Approximately 0V
When brake pedal is slightly depressed	Battery voltage

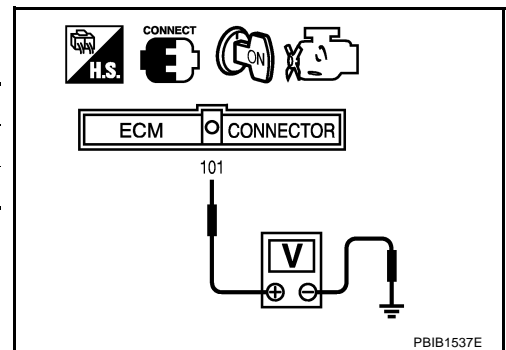

OK or NG

- OK >> **INSPECTION END**
- NG >> GO TO 12.

3. CHECK DTC WITH ICC UNIT

Refer to [ACS-40, "TROUBLE DIAGNOSIS FOR SELF-DIAGNOSTIC ITEMS"](#) .

OK or NG

- OK >> GO TO 4.
- NG >> Repair or replace.

4. CHECK ICC BRAKE SWITCH CIRCUIT

1. Turn ignition switch OFF.
2. Disconnect ICC brake hold relay.
3. Turn ignition switch ON.

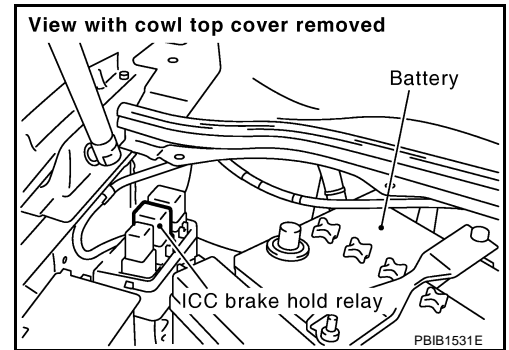

4. Check voltage between ICC brake hold relay terminal 3 and ground with CONSULT-II or tester.

Voltage: Battery voltage

OK or NG

- OK >> GO TO 9.
 NG >> GO TO 5.

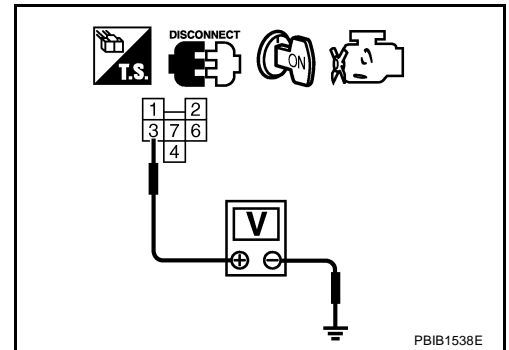

5. CHECK ICC BRAKE SWITCH POWER SUPPLY CIRCUIT

1. Turn ignition switch OFF.
2. Disconnect ICC brake switch harness connector.
3. Turn ignition switch ON.

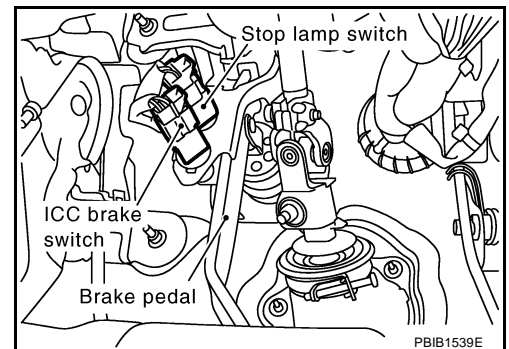

4. Check voltage between ICC brake switch terminal 1 and ground with CONSULT-II or tester.

Voltage: Battery voltage

OK or NG

- OK >> GO TO 7.
 NG >> GO TO 6.

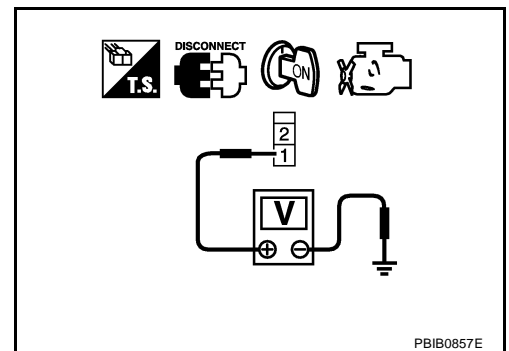

6. DETECT MALFUNCTIONING PART

Check the following.

- Fuse block (J/B) connector M201
- 10A fuse
- Harness for open or short between ICC brake switch and fuse

>> Repair open circuit or short to ground or short to power in harness or connectors.

7. CHECK ICC BRAKE SWITCH INPUT SIGNAL CIRCUIT FOR OPEN AND SHORT-I

1. Turn ignition switch OFF.
2. Check harness continuity between ICC brake hold relay terminal 3 and ICC brake switch terminal 2. Refer to Wiring Diagram.

Continuity should exist.

3. Also check harness for short to ground and short to power.

OK or NG

OK >> GO TO 8.

NG >> Repair open circuit or short to ground or short to power in harness or connectors.

8. CHECK ICC BRAKE SWITCH

Refer to [EC-1301, "Component Inspection"](#) .

OK or NG

OK >> GO TO 17.

NG >> Replace ICC brake switch.

9. CHECK ICC BRAKE SWITCH INPUT SIGNAL CIRCUIT FOR OPEN AND SHORT-II

1. Turn ignition switch OFF.
2. Disconnect ECM harness connector.
3. Check harness continuity between ICC brake hold relay terminal 4 and ECM terminal 108. Refer Wiring Diagram.

Continuity should exist.

4. Also check harness for short to ground and short to power.

OK or NG

OK >> GO TO 11.

NG >> GO TO 10.

10. DETECT MALFUNCTIONING PART

Check the following.

- Harness connectors E211, M41
- Harness for open or short between ICC brake hold relay and ECM

>> Repair open circuit or short to ground or short to power in harness or connectors.

11. CHECK ICC BRAKE HOLD RELAY

Refer to [EC-1301, "Component Inspection"](#) .

OK >> GO TO 17.

NG >> Replace ICC brake fold relay.

12. CHECK STOP LAMP SWITCH POWER SUPPLY CIRCUIT

1. Turn ignition switch OFF.
2. Disconnect stop lamp switch harness connector.

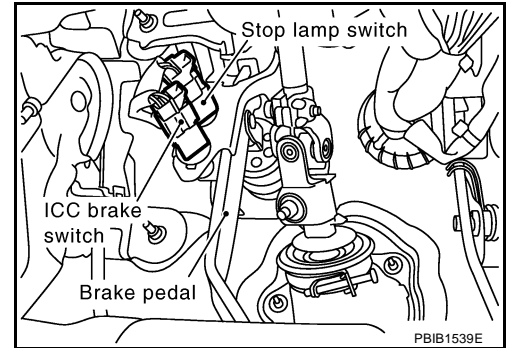

3. Check voltage between stop lamp switch terminal 1 and ground with CONSULT -II or tester.

Voltage: Battery voltage

OK or NG

- OK >> GO TO 14.
- NG >> GO TO 13.

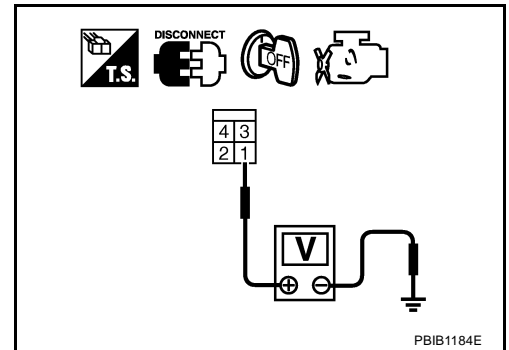

13. DETECT MALFUNCTIONING PART

Check the following.

- Fuse block (J/B) connector E201
- 10A fuse
- Joint connector-2
- Harness for open or short between stop lamp switch and battery

>> Repair open circuit or short to ground or short to power in harness or connectors.

14. CHECK STOP LAMP SWITCH INPUT SIGNAL CIRCUIT FOR OPEN AND SHORT

1. Disconnect ECM harness connector.
2. Check harness continuity between ECM terminal 101 and stop lamp switch terminal 2. Refer to Wiring Diagram.

Continuity should exist.

3. Also check harness for short to ground and short to power.

OK or NG

- OK >> GO TO 16.
- NG >> GO TO 15.

15. DETECT MALFUNCTIONING PART

Check the following.

- Harness connectors E211, M41
- Joint connector-2
- Harness for open or short between ECM and stop lamp switch

>> Repair open circuit or short to ground or short to power in harness or connectors.

16. CHECK STOP LAMP SWITCH

Refer to [EC-1301, "Component Inspection"](#)

OK or NG

OK >> GO TO 17.

NG >> Replace stop lamp switch.

17. CHECK INTERMITTENT INCIDENT

Refer to [EC-784, "TROUBLE DIAGNOSIS FOR INTERMITTENT INCIDENT"](#) .

>> **INSPECTION END**

Component Inspection ICC BRAKE SWITCH

1. Turn ignition switch OFF.
2. Disconnect ICC brake switch harness connector.
3. Check continuity between ICC brake switch terminals 1 and 2 under the following conditions.

Condition	Continuity
When brake pedal is fully released.	Should exist.
When brake pedal is slightly depressed.	Should not exist.

If NG, adjust ICC brake switch installation, refer to [BR-6](#), "[BRAKE PEDAL](#)", and perform step 3 again.

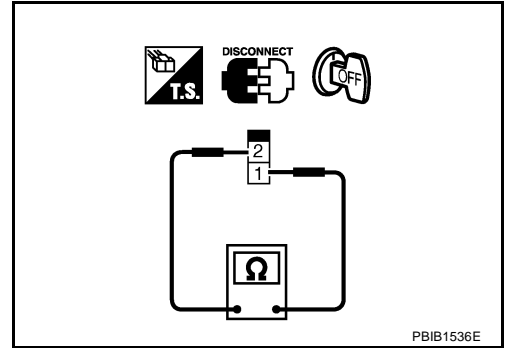

STOP LAMP SWITCH

1. Turn ignition switch OFF.
2. Disconnect stop lamp switch harness connector.
3. Check continuity between stop lamp switch terminals 1 and 2 under the following conditions.

Condition	Continuity
When brake pedal is fully released.	Should not exist.
When brake pedal is slightly depressed.	Should exist.

If NG, adjust stop lamp switch installation, refer to [BR-6](#), "[BRAKE PEDAL](#)", and perform step 3 again.

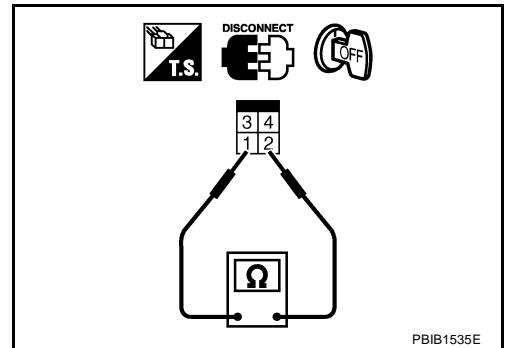

ICC BRAKE HOLD RELAY

1. Apply 12V direct current between ICC brake hold relay terminals 1 and 2.
2. Check continuity between relay terminals 3 and 4, 6 and 7 under the following conditions.

Condition	Between terminals	Continuity
12V direct current supply between terminals 1 and 2	3 and 4	Should not exist
	6 and 7	Should exist
No current supply	3 and 4	Should exist
	6 and 7	Should not exist

3. If NG, replace ICC brake hold relay.

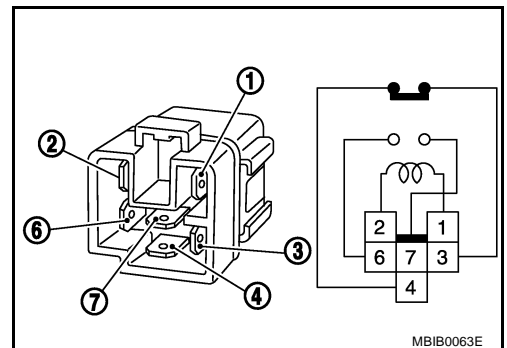

ASC D BRAKE SWITCH

PFP:25320

Component Description

ABS00CFC

When the brake pedal is depressed, ASCD brake switch is turned OFF and stop lamp switch is turned ON. ECM detects the state of the brake pedal by this input of two kinds (ON/OFF signal).

Refer to [EC-1334, "AUTOMATIC SPEED CONTROL DEVICE \(ASC D\)"](#) for the ASCD function.

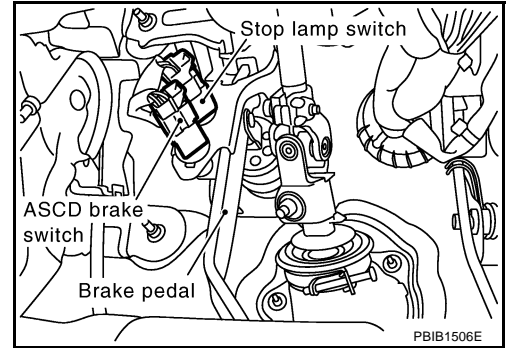

CONSULT-II Reference Value in Data Monitor Mode

ABS00CFD

Specification data are reference values.

MONITOR ITEM	CONDITION		SPECIFICATION
BRAKE SW 1 (ASC D brake switch)	● Ignition switch: ON	● Brake pedal: Fully released	ON
		● Brake pedal: Slightly depressed	OFF
BRAKE SW 2 (stop lamp switch)	● Ignition switch: ON	● Brake pedal: Fully released	OFF
		● Brake pedal: Slightly depressed	ON

ASCD BRAKE SWITCH

[VK45DE]

Wiring Diagram

ABS00CFE

EC-ASCBOF-01

: DETECTABLE LINE FOR DTC
 : NON-DETECTABLE LINE FOR DTC

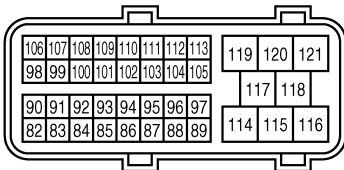
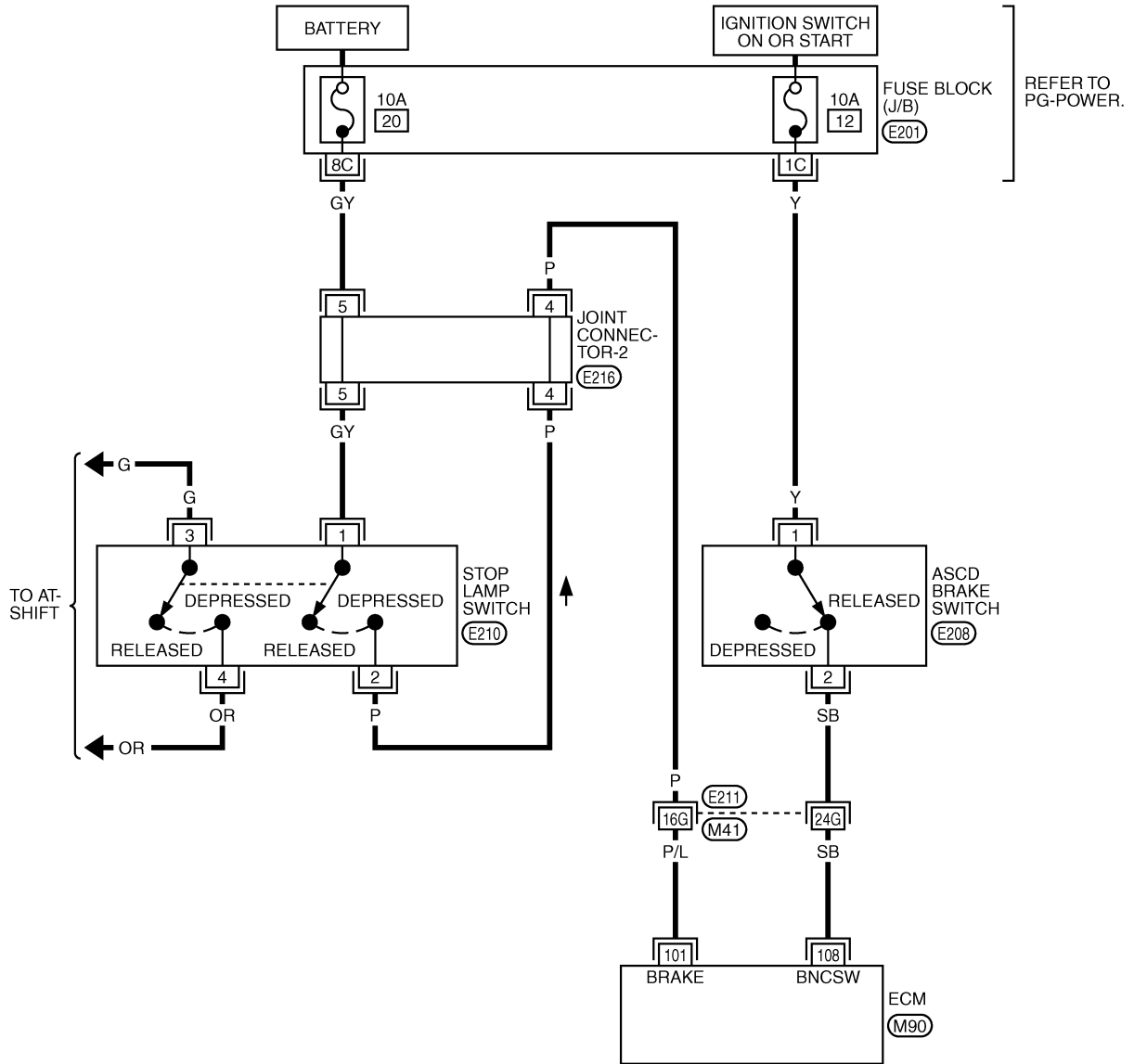

(M90) B



2
1

 (E208) BR

4	3
2	1

 (E210) W

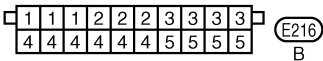

(E216) B

REFER TO THE FOLLOWING.

(E211) -SUPER MULTIPLE JUNCTION (SMJ)

(E201) -FUSE BLOCK-JUNCTION BOX (J/B)

TBWM0266E

ASCD BRAKE SWITCH

[VK45DE]

Specification data are reference values and are measured between each terminal and ground.

CAUTION:

Do not use ECM ground terminals when measuring input/output voltage. Doing so may result in damage to the ECM's transistor. Use a ground other than ECM terminals, such as the ground.

TER-MINAL NO.	WIRE COLOR	ITEM	CONDITION	DATA (DC Voltage)
101	P/L	Stop lamp switch	[Ignition switch: OFF] ● Brake pedal: Fully released	Approximately 0V
			[Ignition switch: OFF] ● Brake pedal: Slightly depressed	BATTERY VOLTAGE (11 - 14V)
108	SB	ASCD brake switch	[Ignition switch: ON] ● Brake pedal: Slightly depressed	Approximately 0V
			[Ignition switch: ON] ● Brake pedal: Fully released	BATTERY VOLTAGE (11 - 14V)

Diagnostic Procedure

ABS00CFF

1. CHECK OVERALL FUNCTION-I

 **With CONSULT-II**

- Turn ignition switch ON.
- Select "BRAKE SW1" in "DATA MONITOR" mode with CONSULT-II.
- Check "BRAKE SW1" indication under the following conditions.

CONDITION	INDICATION
When brake pedal is slightly depressed	OFF
When brake pedal is fully released	ON

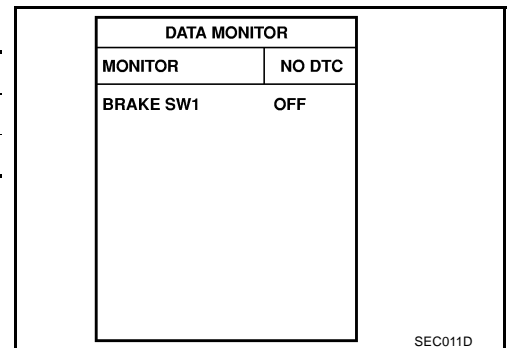

 **Without CONSULT-II**

- Turn ignition switch ON.
- Check voltage between ECM terminal 108 and ground under the following conditions.

CONDITION	VOLTAGE
When brake pedal is slightly depressed	Approximately 0V
When brake pedal is fully released	Battery voltage

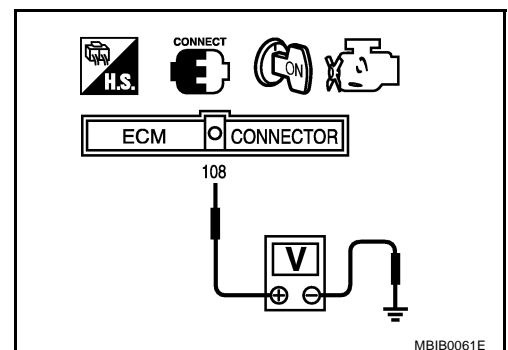

OK or NG

- OK >> GO TO 2.
 NG >> GO TO 3.

ASCD BRAKE SWITCH

[VK45DE]

2. CHECK OVERALL FUNCTION-II

With CONSULT-II

Check "BRAKE SW2" indication in "DATA MONITOR" mode.

CONDITION	INDICATION
When brake pedal is fully released	OFF
When brake pedal is slightly depressed	ON

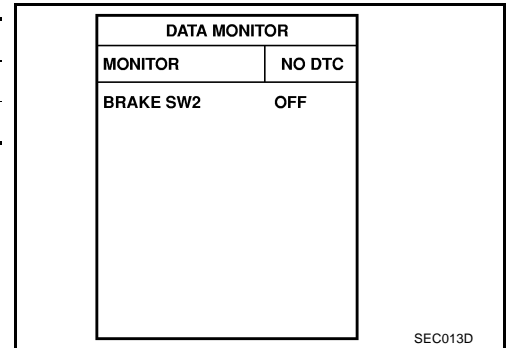

Without CONSULT-II

Check voltage between ECM terminal 101 and ground under the following conditions.

CONDITION	VOLTAGE
When brake pedal is fully released	Approximately 0V
When brake pedal is slightly depressed	Battery voltage

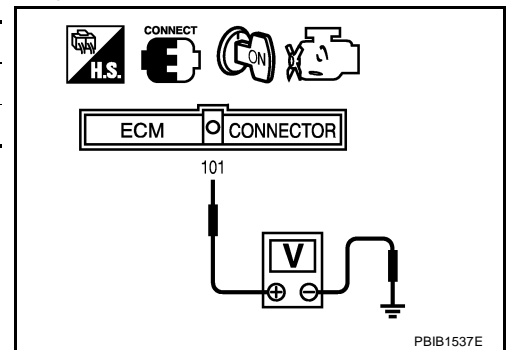

OK or NG

OK >> **INSPECTION END**
 NG >> GO TO 8.

3. CHECK ASCD BRAKE SWITCH POWER SUPPLY CIRCUIT

1. Turn ignition switch OFF.
2. Disconnect ASCD brake switch harness connector.
3. Turn ignition switch ON.

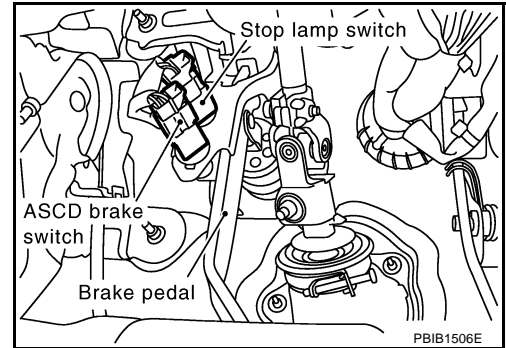

4. Check voltage between ASCD brake switch terminal 1 and ground with CONSULT-II or tester.

Voltage: Battery voltage

OK or NG

- OK >> GO TO 5.
- NG >> GO TO 4.

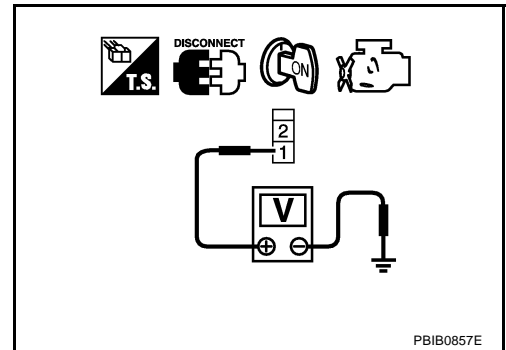

4. DETECT MALFUNCTIONING PART

Check the following.

- Fuse block (J/B) connector E201
- 10A fuse
- Harness for open or short between ASCD brake switch and fuse

>> Repair open circuit or short to ground or short to power in harness or connectors.

5. CHECK ASCD BRAKE SWITCH INPUT SIGNAL CIRCUIT FOR OPEN AND SHORT

1. Turn ignition switch OFF.
2. Disconnect ECM harness connector.
3. Check harness continuity between ECM terminal 108 and ASCD brake switch terminal 2. Refer to Wiring Diagram.

Continuity should exist.

4. Also check harness for short to ground or short to power.

OK or NG

- OK >> GO TO 7.
- NG >> GO TO 6.

6. DETECT MALFUNCTIONING PART

Check the following.

- Harness connectors E211, M41
- Harness for open or short between ECM and ASCD brake switch

>> Repair open circuit or short to ground or short to power in harness or connectors.

7. CHECK ASCD BRAKE SWITCH

Refer to [EC-1206, "Component Inspection"](#)

OK or NG

- OK >> GO TO 13.
- NG >> Replace ASCD brake switch.

8. CHECK STOP LAMP SWITCH POWER SUPPLY CIRCUIT

1. Turn ignition switch OFF.
2. Disconnect stop lamp switch harness connector.

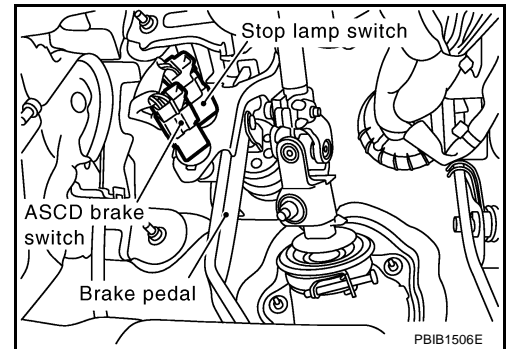

3. Check voltage between stop lamp switch terminal 1 and ground with CONSULT -II or tester.

Voltage: Battery voltage

OK or NG

- OK >> GO TO 10.
- NG >> GO TO 9.

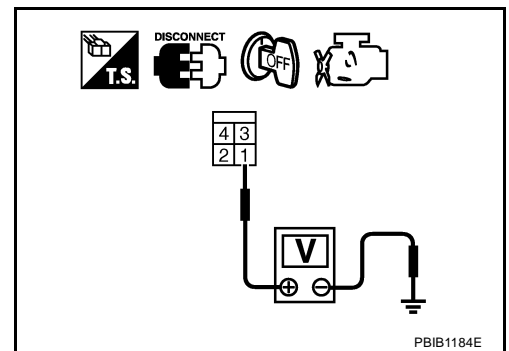

9. DETECT MALFUNCTIONING PART

Check the following.

- Fuse block (J/B) connector E201
- 10A fuse
- Joint connector-2
- Harness for open or short between stop lamp switch and battery

>> Repair open circuit or short to ground or short to power in harness or connectors.

10. CHECK STOP LAMP SWITCH INPUT SIGNAL CIRCUIT FOR OPEN AND SHORT

1. Disconnect ECM harness connector.
2. Check harness continuity between ECM terminal 101 and stop lamp switch terminal 2. Refer to Wiring Diagram.

Continuity should exist.

3. Also check harness for short to ground and short to power.

OK or NG

- OK >> GO TO 12.
- NG >> GO TO 11.

11. DETECT MALFUNCTIONING PART

Check the following.

- Harness connectors E211, M41
- Joint connector-2
- Harness for open or short between ECM and stop lamp switch

>> Repair open circuit or short to ground or short to power in harness or connectors.

12. CHECK STOP LAMP SWITCH

Refer to [EC-1206, "Component Inspection"](#)

OK or NG

- OK >> GO TO 13.
 NG >> Replace stop lamp switch.

13. CHECK INTERMITTENT INCIDENT

Refer to [EC-784, "TROUBLE DIAGNOSIS FOR INTERMITTENT INCIDENT"](#) .

>> **INSPECTION END**

Component Inspection ASC D BRAKE SWITCH

ABS00CFG

1. Turn ignition switch OFF.
2. Disconnect ASCD brake switch harness connector.
3. Check harness continuity between ASCD brake switch terminals 1 and 2 under the following conditions.

Condition	Continuity
When brake pedal is fully released.	Should exist.
When brake pedal is slightly depressed.	Should not exist.

If NG, adjust ASCD brake switch installation, refer to [BR-6, "BRAKE PEDAL"](#) , and perform step 3 again.

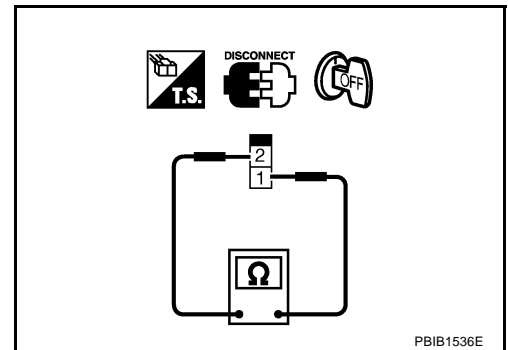

STOP LAMP SWITCH

1. Turn ignition switch OFF.
2. Disconnect stop lamp switch harness connector.
3. Check harness continuity between stop lamp switch terminals 1 and 2 under the following conditions.

Condition	Continuity
When brake pedal is fully released.	Should not exist.
When brake pedal is slightly depressed.	Should exist.

If NG, adjust stop lamp switch installation, refer to [BR-6, "BRAKE PEDAL"](#) , and perform step 3 again.

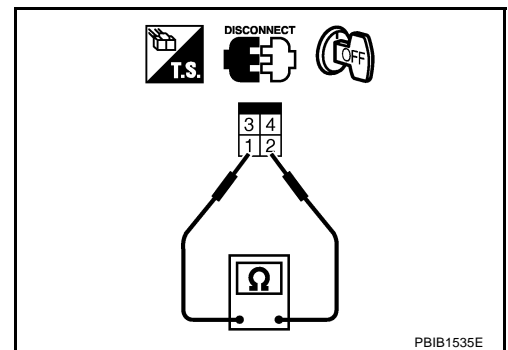

ASC D INDICATOR

PFP:24814

Component Description

ABS00CFH

ASC D indicator lamp illuminates to indicate ASC D operation status. Lamp has two indicators, CRUISE and SET, and is integrated in combination meter.

CRUISE indicator illuminates when ON/OFF (MAIN) switch on ASC D steering switch is turned ON to indicated that ASC D system is ready for operation.

SET indicator illuminates when following conditions are met.

- CRUISE indicator is illuminated.
- COAST/SET switch on ASC D steering switch is turned ON while vehicle speed is within the range of ASC D setting.

SET indicator remains lit during ASC D control.

Refer to [EC-1334, "AUTOMATIC SPEED CONTROL DEVICE \(ASC D\)"](#) for the ASC D function.

CONSULT-II Reference Value in Data Monitor Mode

ABS00CFI

Specification data are reference value.

MONITOR ITEM	CONDITION		SPECIFICATION
CRUISE LAMP	● Ignition switch: ON	● ON/OFF (MAIN) switch: Pressed at the 1st time → at the 2nd time	ON → OFF
SET LAMP	● ON/OFF (MAIN) switch: ON ● When vehicle speed is between 40 km/h (25 MPH) and 144 km/h (89 MPH)	● ASC D is operating	ON
		● ASC D is not operating	OFF

ASC D INDICATOR

[VK45DE]

ABS00CFJ

Wiring Diagram

EC-ASCIND-01

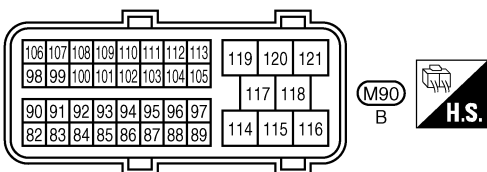
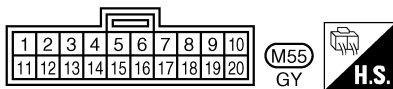
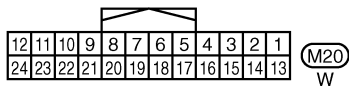
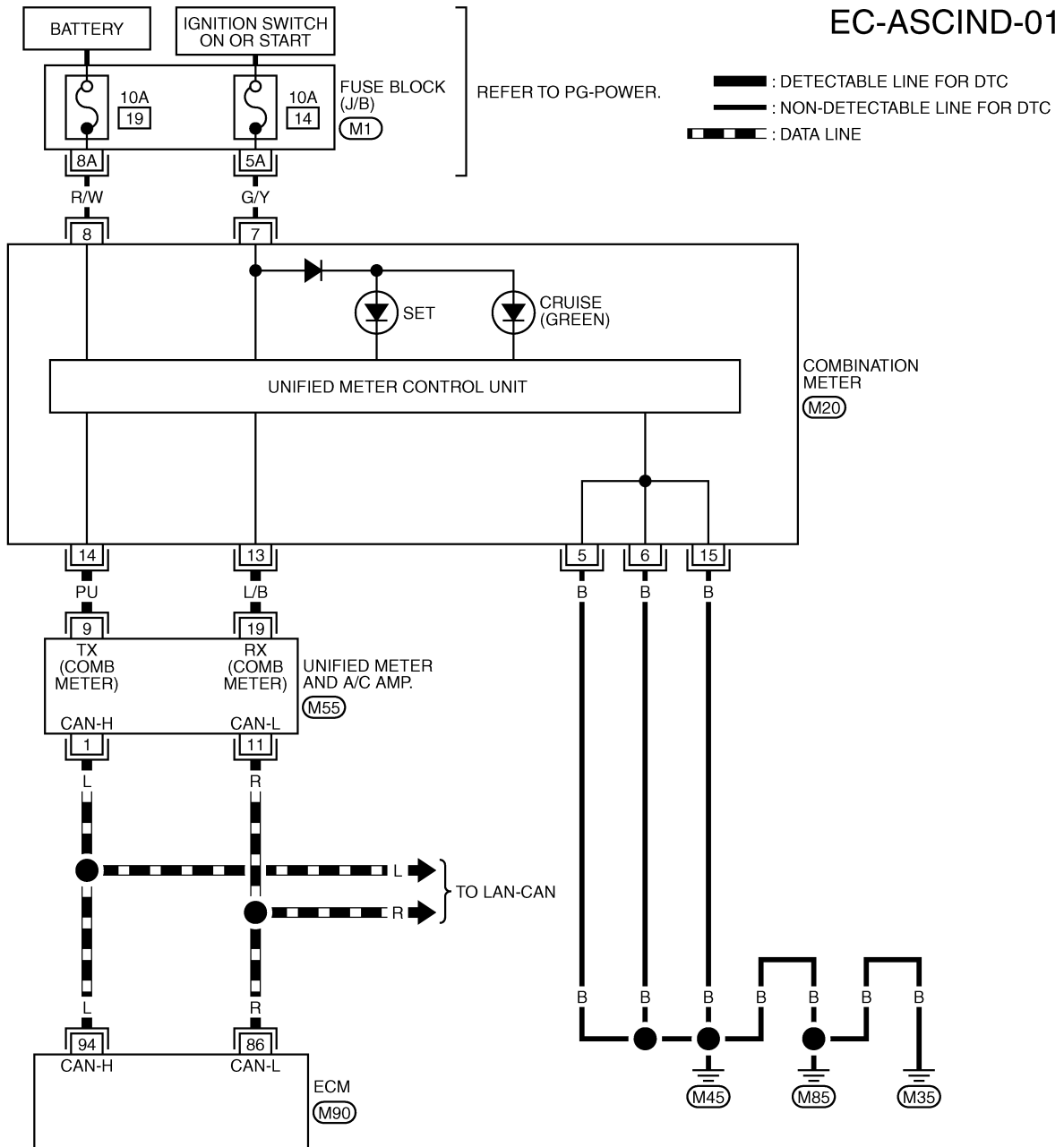

REFER TO THE FOLLOWING.

(M1) - FUSE BLOCK-JUNCTION BOX (J/B)

TBWM0267E

Diagnostic Procedure

1. CHECK OVERALL FUNCTION

Check ASCD indicator under the following conditions.

ASCD INDICATOR	CONDITION		SPECIFICATION
CRUISE LAMP	<ul style="list-style-type: none"> ● Ignition switch: ON 	<ul style="list-style-type: none"> ● ON/OFF (MAIN) switch: Pressed at the 1st time → at the 2nd time 	ON → OFF
SET LAMP	<ul style="list-style-type: none"> ● ON/OFF (MAIN) switch: ON ● When vehicle speed is between 40 km/h (25 MPH) and 144 km/h (89 MPH) 	<ul style="list-style-type: none"> ● ASCD is operating 	ON
		<ul style="list-style-type: none"> ● ASCD is not operating 	OFF

OK or NG

OK >> **INSPECTION END**

NG >> GO TO 2.

2. CHECK DTC

Check that DTC U1000 or U1001 is not displayed.

OK or NG

OK >> GO TO 3.

NG >> Perform trouble diagnosis for DTC U1000, U1001. Refer to [EC-792, "DTC U1000, U1001 CAN COMMUNICATION LINE"](#).

3. CHECK DTC WITH "UNIFIED METER AND A/C AMP."

Refer to [DI-32, "SELF-DIAGNOSTIC RESULTS"](#).

OK or NG

OK >> GO TO 4.

NG >> Go to [DI-22, "Communication Line Inspection"](#).

4. CHECK INTERMITTENT INCIDENT

Refer to [EC-784, "TROUBLE DIAGNOSIS FOR INTERMITTENT INCIDENT"](#).

>> **INSPECTION END**

SNOW MODE SWITCH

[VK45DE]

SNOW MODE SWITCH

PFP:25130

Description

ABS00CFL

NOTE:

If DTC U1000 or U1001 are displayed, first perform the trouble diagnosis for DTC U1000, U1001.

Refer to [EC-792, "DTC U1000, U1001 CAN COMMUNICATION LINE"](#).

The snow mode switch signal is sent to the "unified meter and A/C amp." from the snow mode switch. The "unified meter and A/C amp." then sends the signal to the ECM by CAN communication line.

The snow mode is used for driving or starting the vehicle on snowy roads or slippery areas. If the snow mode is activated, the vehicle speed will not be accelerated immediately than your original pedal in due to avoid the vehicle slip. In other words, ECM controls the rapid engine torque change by controlling the electric throttle control actuator operating speed.

CONSULT-II Reference Value in the Data Monitor Mode

ABS00CFM

MONITOR ITEM	CONDITION		SPECIFICATION
SNOW MODE SW	● Ignition switch: ON	Snow mode switch: ON	ON
		Snow mode switch: OFF	OFF

SNOW MODE SWITCH

[VK45DE]

ABS00CFN

Wiring Diagram

EC-SNOWSW-01

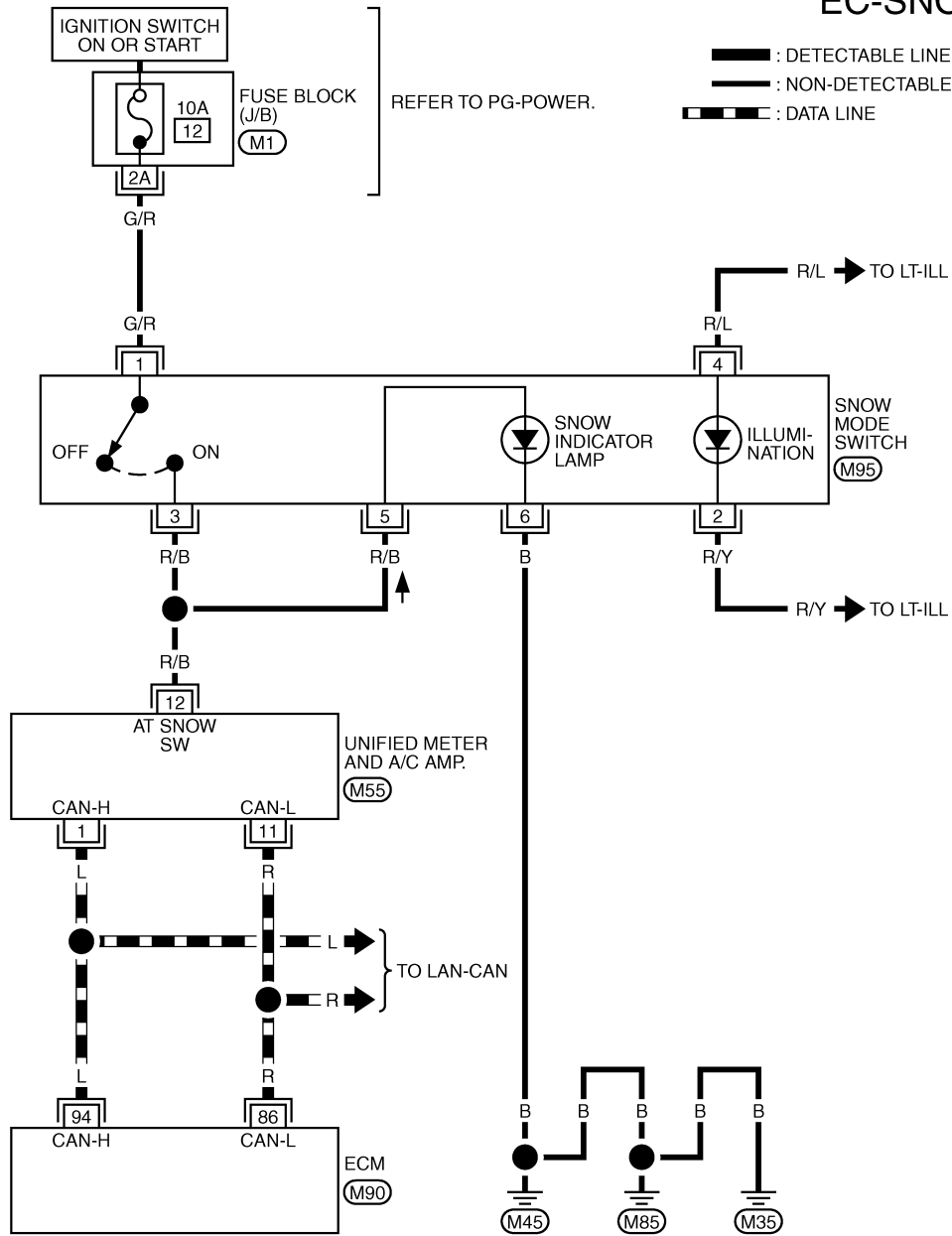

— : DETECTABLE LINE FOR DTC
 — : NON-DETECTABLE LINE FOR DTC
 - - - : DATA LINE

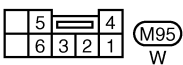
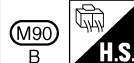
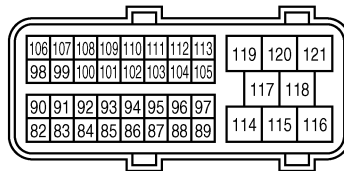
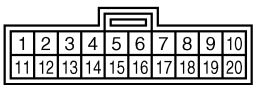

REFER TO THE FOLLOWING.

(M1) - FUSE BLOCK-JUNCTION BOX (J/B)

TBWH0217E

SNOW MODE SWITCH

[VK45DE]

ABS00CFO

Diagnostic Procedure

1. CHECK SNOW MODE SWITCH OVERALL FUNCTION-I

1. Turn ignition switch ON.
2. Select "SNOW MODE SW" in "DATA MONITOR" mode with CONSULT-II.
3. Check "SNOW MODE SW" indication under the following conditions.

CONDITION	INDICATION
Snow mode switch: ON	ON
Snow mode switch: OFF	OFF

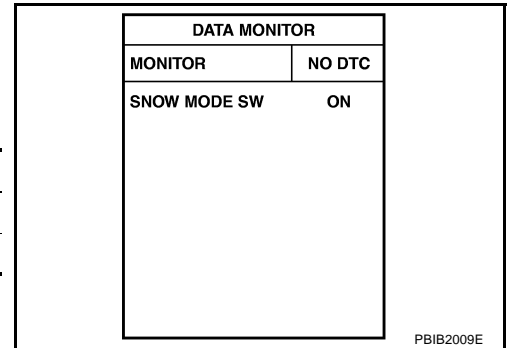

OK or NG

- OK >> GO TO 2.
NG >> GO TO 3.

2. CHECK SNOW MODE SWITCH OVERALL FUNCTION-II

1. Start engine.
2. Check the snow mode indicator in the snow mode switch under the following condition.

CONDITION	INDICATION
Snow mode switch: ON	ON
Snow mode switch: OFF	OFF

OK or NG

- OK >> **INSPECTION END**
NG >> GO TO 3.

3. CHECK GROUND CONNECTIONS

1. Turn ignition switch OFF.
2. Loosen and retighten three ground screws on the body.
Refer to [EC-791, "Ground Inspection"](#).

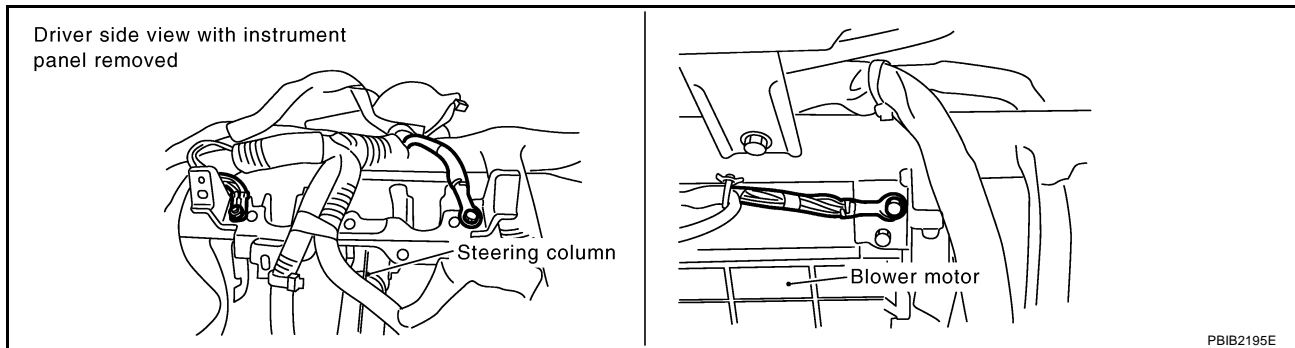

OK or NG

- OK >> GO TO 4.
NG >> Repair or replace ground connections.

4. CHECK POWER SUPPLY CIRCUIT-I

1. Turn ignition switch OFF.
2. Disconnect "unified meter and A/C amp." harness connector.
3. Turn ignition switch ON.
4. Check voltage between "unified meter and A/C amp." terminal 12 and ground under the following conditions with CONSULT-II or tester.

CONDITION	VOLTAGE
Snow mode switch: ON	Battery voltage
Snow mode switch: OFF	0V

OK or NG

- OK >> GO TO 8.
 NG >> GO TO 5.

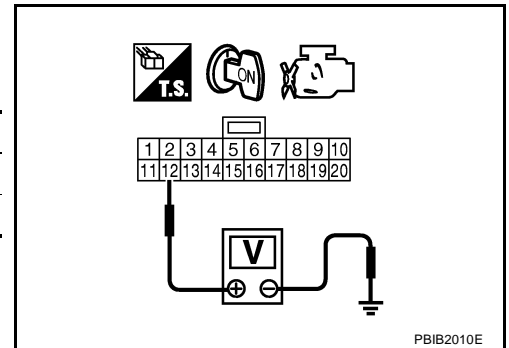

5. CHECK POWER SUPPLY CIRCUIT-II

1. Turn ignition switch OFF.
2. Disconnect snow mode switch.
3. Turn ignition switch ON.
4. Check voltage between snow mode switch terminal 1 and ground with CONSULT-II or tester.

Voltage: Battery voltage.

OK or NG

- OK >> GO TO 7.
 NG >> GO TO 6.

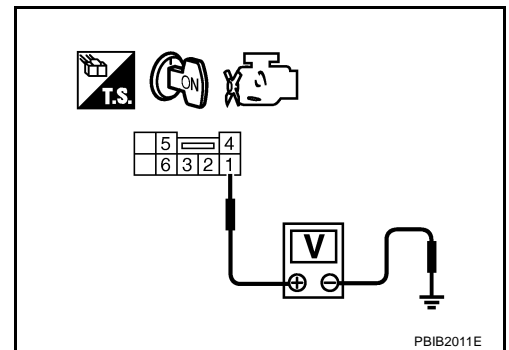

6. DETECT MALFUNCTIONING PART

Check the following.

- 10A fuse
- Harness for open or short between snow mode switch and fuse.

>> Repair open circuit or short to ground or short to power in harness or connectors.

7. CHECK SNOW MODE SWITCH OUT PUT SIGNAL CIRCUIT FOR OPEN AND SHORT

1. Turn ignition switch OFF.
2. Check harness continuity between snow mode switch terminal 3 and "unified meter and A/C amp." terminal 12. Refer to Wiring Diagram.

Continuity should exist.

3. Also check harness for short to ground and short to power.

OK or NG

- OK >> GO TO 8.
 NG >> Repair open circuit or short to ground or short to power in harness or connectors.

8. CHECK SNOW MODE INDICATOR LAMP INPUT SIGNAL CIRCUIT FOR OPEN AND SHORT

1. Turn ignition switch OFF.
2. Disconnect snow mode switch harness connector.
3. Check harness continuity between snow mode switch terminal 5 and "unified meter and A/C amp." terminal 12. Refer to Wiring Diagram.

Continuity should exist.

4. Also check harness for short to ground and short to power.

OK or NG

OK >> GO TO 9.

NG >> Repair open circuit or short to ground or short to power in harness or connectors.

9. CHECK SNOW MODE INDICATOR LAMP GROUND CIRCUIT FOR OPEN AND SHORT

1. Check harness continuity between snow mode switch terminal 6 and ground. Refer to Wiring Diagram.

Continuity should exist.

2. Also check harness for short to power.

OK or NG

OK >> GO TO 10.

NG >> Repair open circuit or short to power in harness or connectors.

10. CHECK SNOW MODE INDICATOR LAMP

Check harness continuity between snow mode switch terminals 5 and 6 under the following conditions.

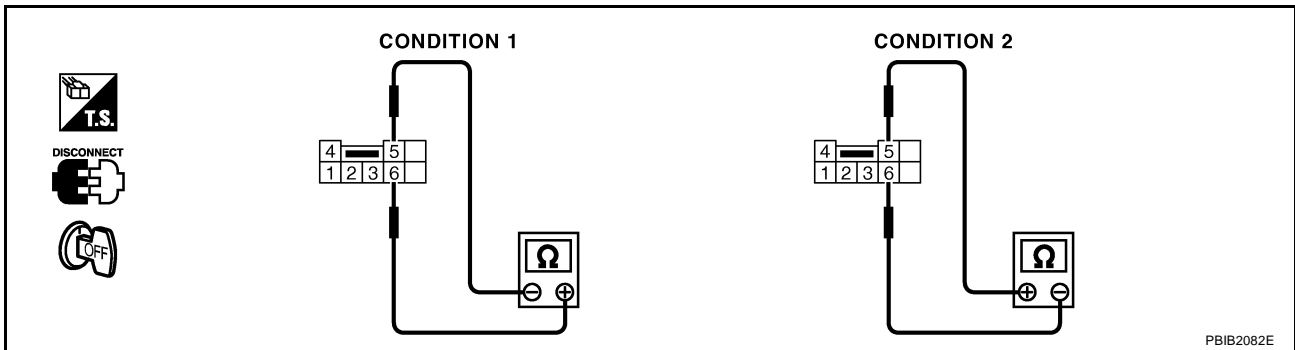

Condition	Continuity
1	Should exist.
2	Should not exist.

OK or NG

OK >> GO TO 11.

NG >> Replace snow mode switch.

11. CHECK SNOW MODE SWITCH

Refer to [EC-1317, "Component Inspection"](#) .

OK or NG

OK >> GO TO 12.

NG >> Replace snow mode switch.

12. CHECK "UNIFIED METER AND A/C AMP."

Refer to [DI-28, "UNIFIED METER AND A/C AMP"](#) .

OK or NG

- OK >> GO TO 13.
- NG >> Replace "unified meter and A/C amp."

13. CHECK INTERMITTENT INCIDENT

Refer to [EC-784, "TROUBLE DIAGNOSIS FOR INTERMITTENT INCIDENT"](#) .

>> INSPECTION END

Component Inspection SNOW MODE SWITCH

ABS00CFP

- Check snow mode switch continuity between terminals 1 and 3 under the following condition.

CONDITION	CONTINUITY
Snow mode switch is ON	Should exist
Snow mode switch is OFF	Should not exist

- If NG, replace snow mode switch.

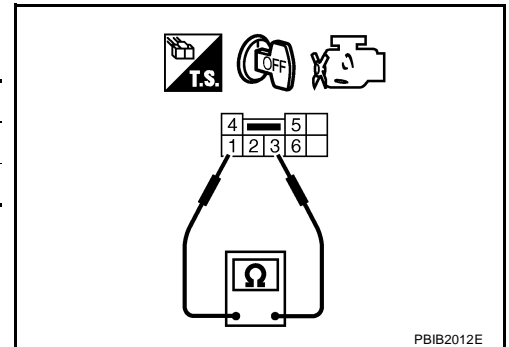

A
EC
C
D
E
F
G
H
I
J
K
L
M

MIL AND DATA LINK CONNECTOR

[VK45DE]

MIL AND DATA LINK CONNECTOR

PFP:24814

Wiring Diagram

ABS00CF0

EC-MIL/DL-01

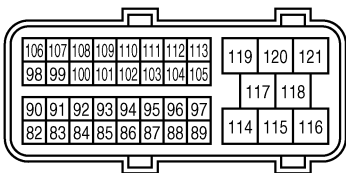
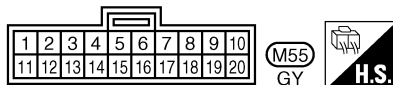
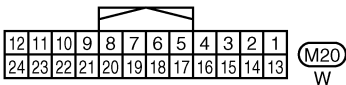
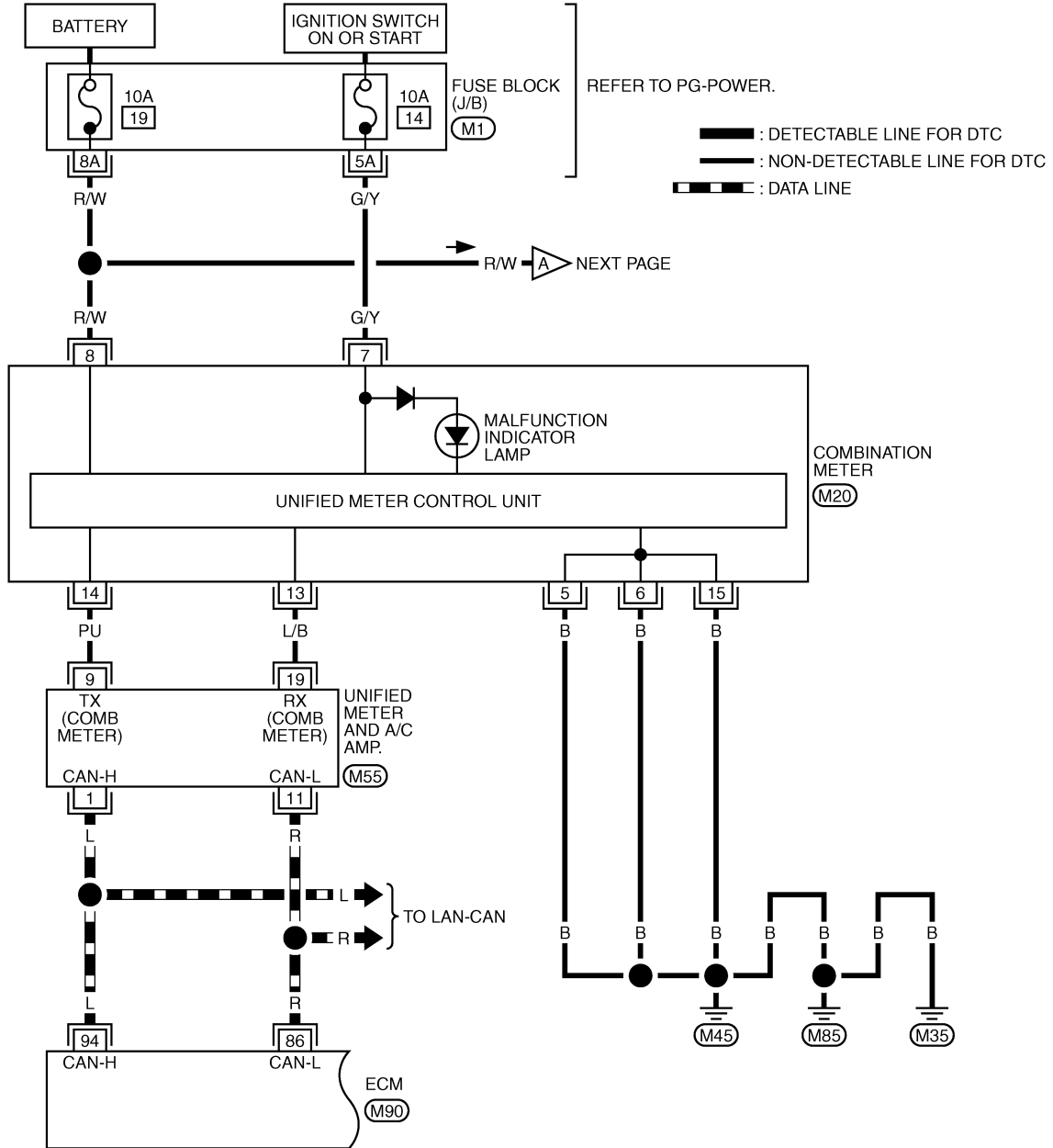

REFER TO THE FOLLOWING.

(M1) - FUSE BLOCK-JUNCTION BOX (J/B)

TBWM0268E

MIL AND DATA LINK CONNECTOR

[VK45DE]

EC-MIL/DL-02

A

EC

C

D

E

F

G

H

I

J

K

L

M

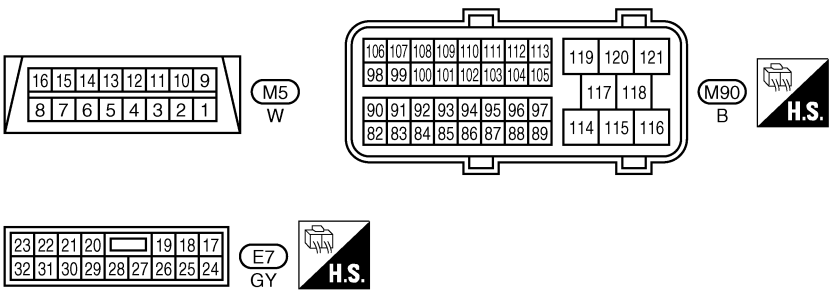
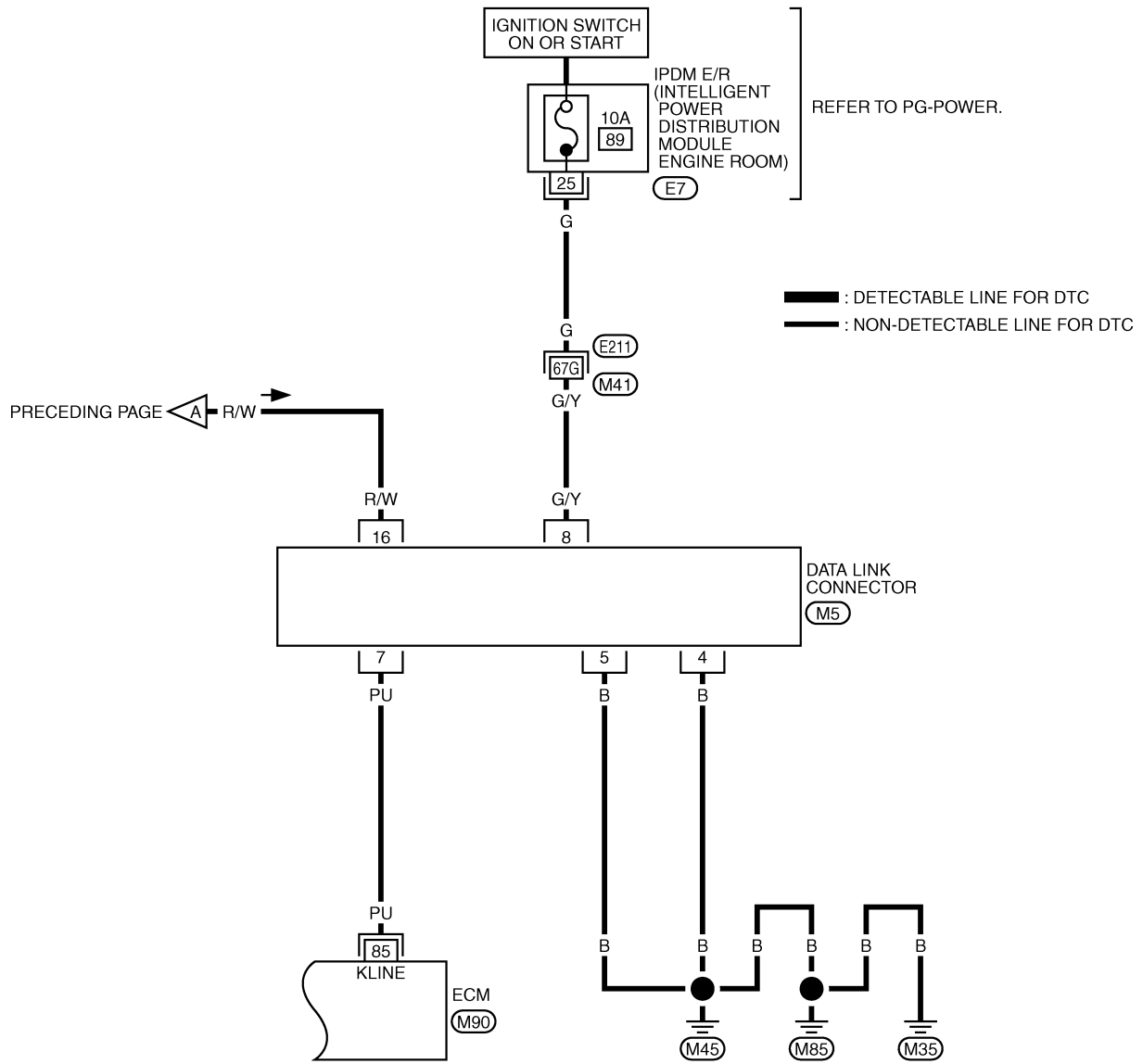

REFER TO THE FOLLOWING.

E211 -SUPER MULTIPLE JUNCTION (SMJ)

TBWM0269E

EVAPORATIVE EMISSION SYSTEM

PFP:14950

Description SYSTEM DESCRIPTION

ABS00CFR

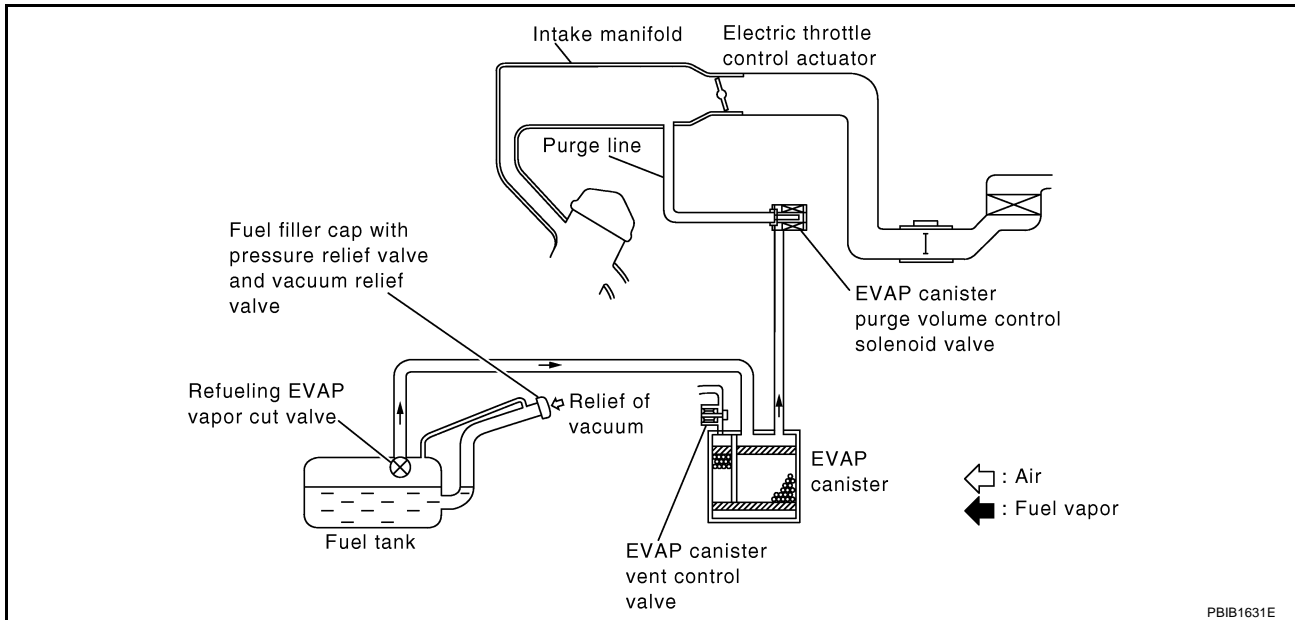

The evaporative emission system is used to reduce hydrocarbons emitted into the atmosphere from the fuel system. This reduction of hydrocarbons is accomplished by activated charcoals in the EVAP canister. The fuel vapor in the sealed fuel tank is led into the EVAP canister which contains activated carbon and the vapor is stored there when the engine is not operating or when refueling to the fuel tank. The vapor in the EVAP canister is purged by the air through the purge line to the intake manifold when the engine is operating. EVAP canister purge volume control solenoid valve is controlled by ECM. When the engine operates, the flow rate of vapor controlled by EVAP canister purge volume control solenoid valve is proportionally regulated as the air flow increases. EVAP canister purge volume control solenoid valve also shuts off the vapor purge line during decelerating and idling.

EVAPORATIVE EMISSION SYSTEM

[VK45DE]

EVAPORATIVE EMISSION LINE DRAWING

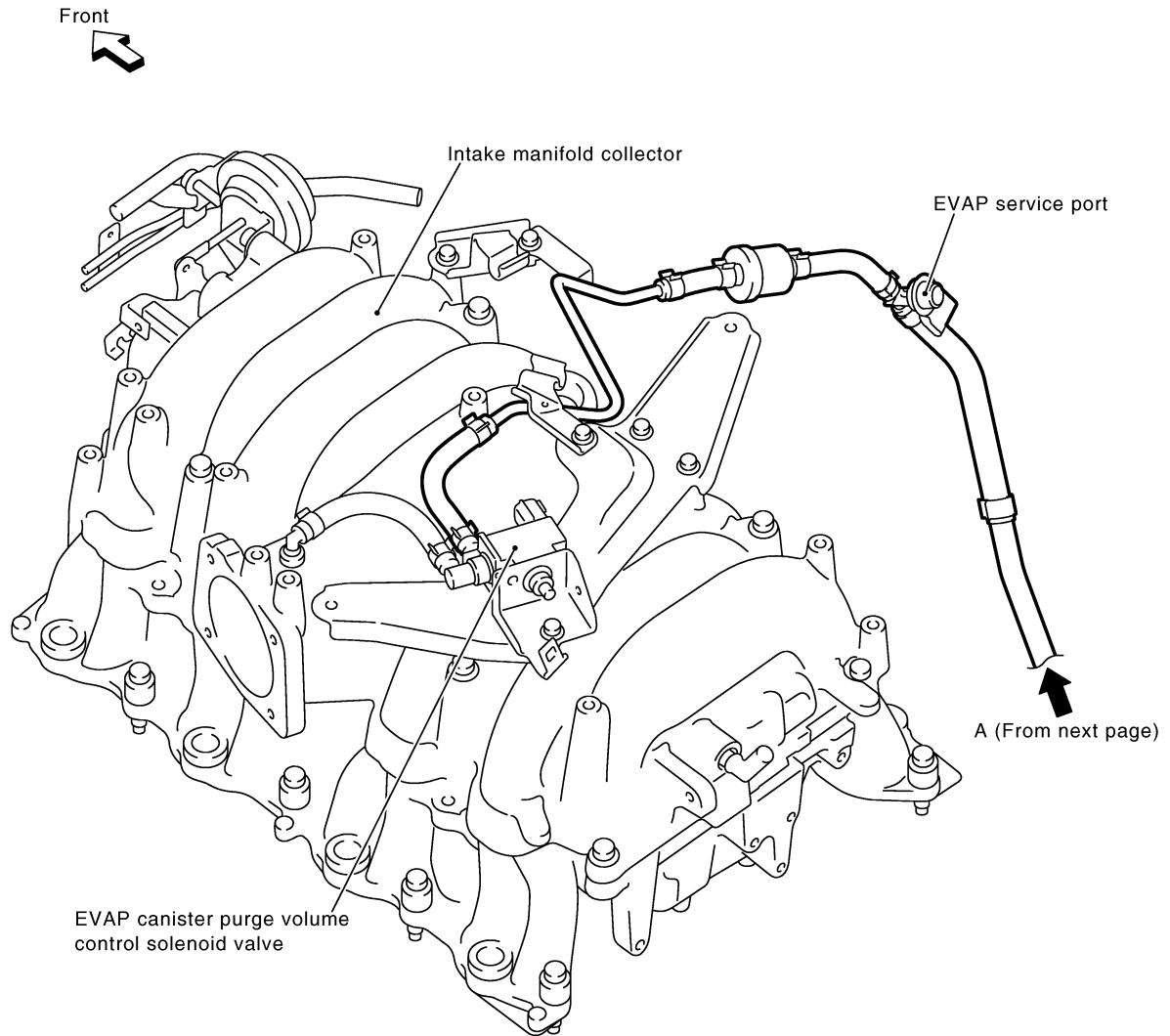

NOTE : Do not use soapy water or any type of solvent while installing vacuum hose or purge hoses.

PBIB1524E

A
EC
C
D
E
F
G
H
I
J
K
L
M

EVAPORATIVE EMISSION SYSTEM

[VK45DE]

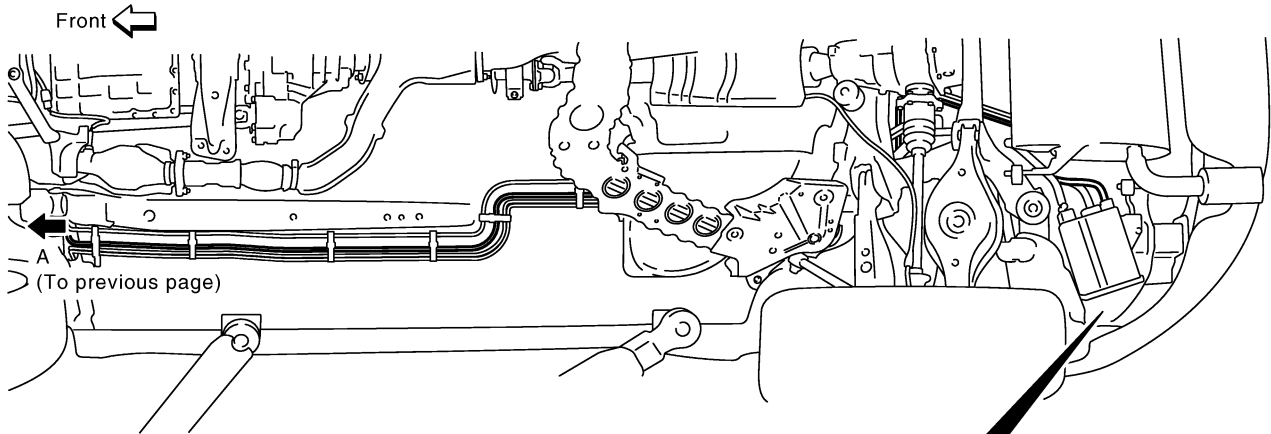

View from under the vehicle

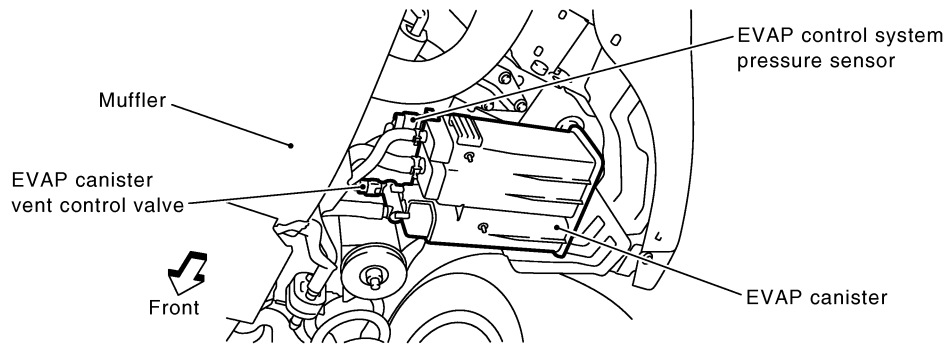

PBIB1523E

Component Inspection EVAP CANISTER

Check EVAP canister as follows:

1. Block port **B** .
2. Blow air into port **A** and check that it flows freely out of port **C** .
3. Release blocked port **B** .
4. Apply vacuum pressure to port **B** and check that vacuum pressure exists at the ports **A** and **C** .
5. Block port **A** and **B** .
6. Apply pressure to port **C** and check that there is no leakage.

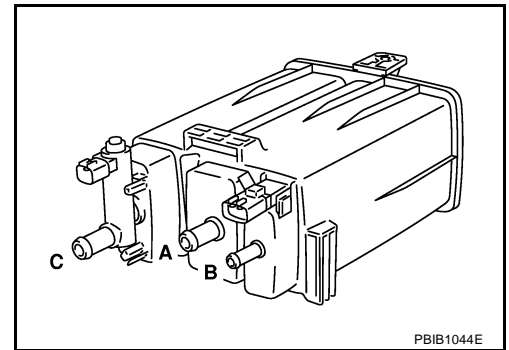

PBIB1044E

FUEL TANK VACUUM RELIEF VALVE (BUILT INTO FUEL FULLER CAP)

1. Wipe clean valve housing.

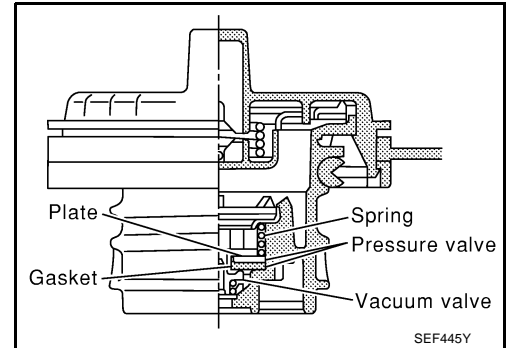

SEF445Y

2. Check valve opening pressure and vacuum.

Pressure: 15.3 - 20.0 kPa (0.156 - 0.204 kg/cm² , 2.22 - 2.90 psi)

Vacuum: -6.0 to -3.3 kPa (-0.061 to -0.034 kg/cm² , -0.87 to -0.48 psi)

3. If out of specification, replace fuel filler cap as an assembly.

CAUTION:

Use only a genuine fuel filler cap as a replacement. If an incorrect fuel filler cap is used, the MIL may come on.

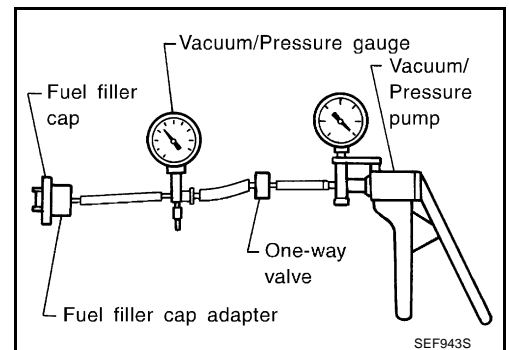

SEF943S

EVAP CANISTER PURGE VOLUME CONTROL SOLENOID VALVE

Refer to [EC-995](#) .

FUEL TANK TEMPERATURE SENSOR

Refer to [EC-941](#) .

EVAP CANISTER VENT CONTROL VALVE

Refer to [EC-1002](#) .

EVAP CONTROL SYSTEM PRESSURE SENSOR

Refer to [EC-1013](#) .

EVAP SERVICE PORT

Positive pressure is delivered to the EVAP system through the EVAP service port. If fuel vapor leakage in the EVAP system occurs, use a leak detector to locate the leak.

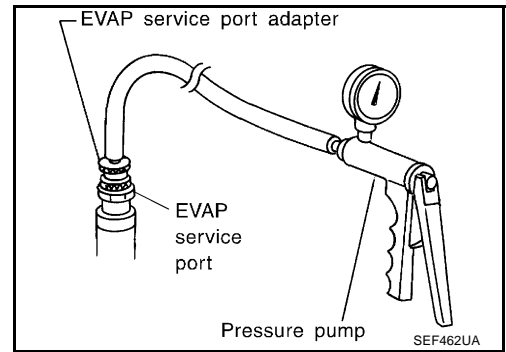

ABS00CFT

Removal and Installation EVAP CANISTER

Tighten EVAP canister as shown in the figure.

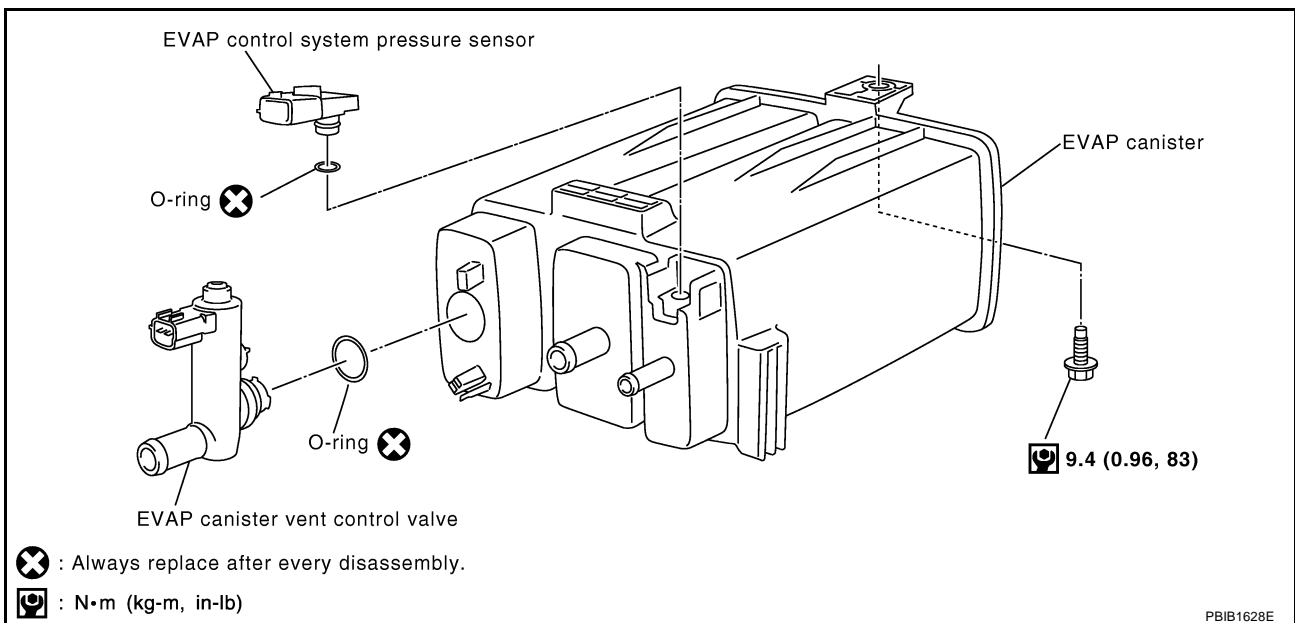

PBIB1628E

EVAP CANISTER VENT CONTROL VALVE

1. Turn EVAP canister vent control valve counterclockwise.
2. Remove the EVAP canister vent control valve.

Always replace O-ring with a new one.

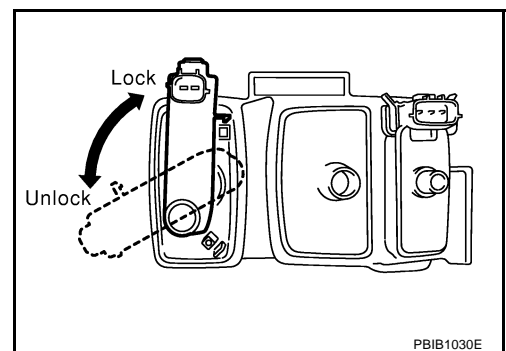

PBIB1030E

How to Detect Fuel Vapor Leakage

CAUTION:

- Do not use compressed air or a high pressure pump.
- Do not exceed 4.12 kPa (0.042 kg/cm², 0.6 psi) of pressure in EVAP system.

NOTE:

- Do not start engine.
- Improper installation of EVAP service port adapter to the EVAP service port may cause a leak.

ABS00CFU

WITH CONSULT-II

1. Attach the EVAP service port adapter securely to the EVAP service port.
2. Also attach the pressure pump and hose to the EVAP service port adapter.
3. Turn ignition switch ON.
4. Select the "EVAP SYSTEM CLOSE" of "WORK SUPPORT MODE" with CONSULT-II.
5. Touch "START". A bar graph (Pressure indicating display) will appear on the screen.

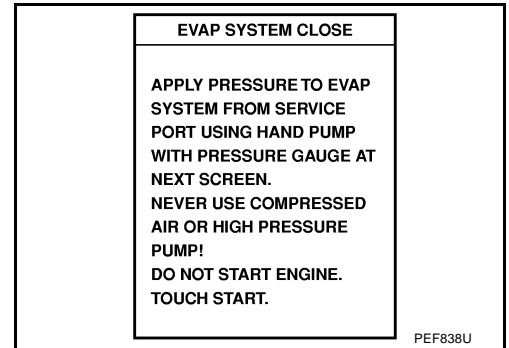

6. Apply positive pressure to the EVAP system until the pressure indicator reaches the middle of the bar graph.
7. Remove EVAP service port adapter and hose with pressure pump.

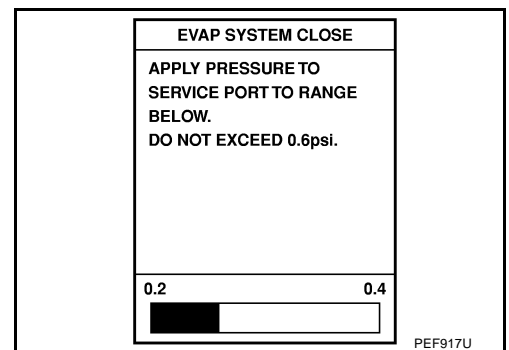

8. Locate the leak using a leak detector. Refer to [EC-1321, "EVAPORATIVE EMISSION LINE DRAWING"](#).

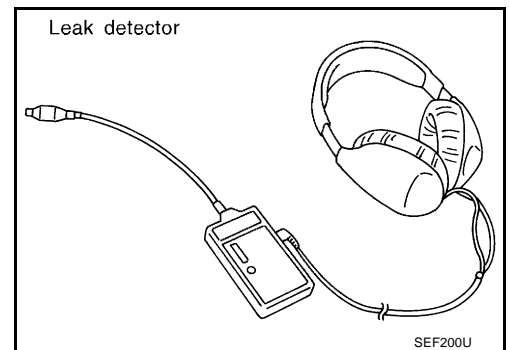

WITHOUT CONSULT-II

1. Attach the EVAP service port adapter securely to the EVAP service port.
2. Also attach the pressure pump with pressure gauge to the EVAP service port adapter.

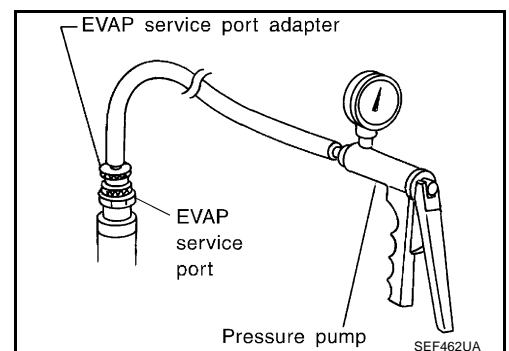

A
EC
C
D
E
F
G
H
I
J
K
L
M

EVAPORATIVE EMISSION SYSTEM

[VK45DE]

3. Apply battery voltage between the terminals of EVAP canister vent control valve to make a closed EVAP system.

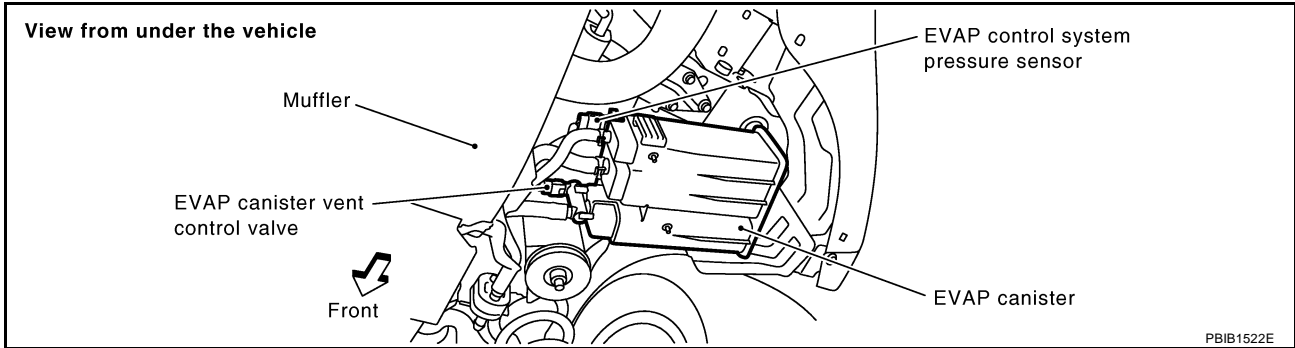

4. To locate the leak, deliver positive pressure to the EVAP system until pressure gauge points reach 1.38 to 2.76 kPa (0.014 to 0.028 kg/cm² , 0.2 to 0.4 psi).
5. Remove EVAP service port adapter and hose with pressure pump.
6. Locate the leak using a leak detector. Refer to [EC-1321, "EVAPORATIVE EMISSION LINE DRAWING"](#) .

ON BOARD REFUELING VAPOR RECOVERY (ORVR)

PFP:00032

System Description

ABS00CFV

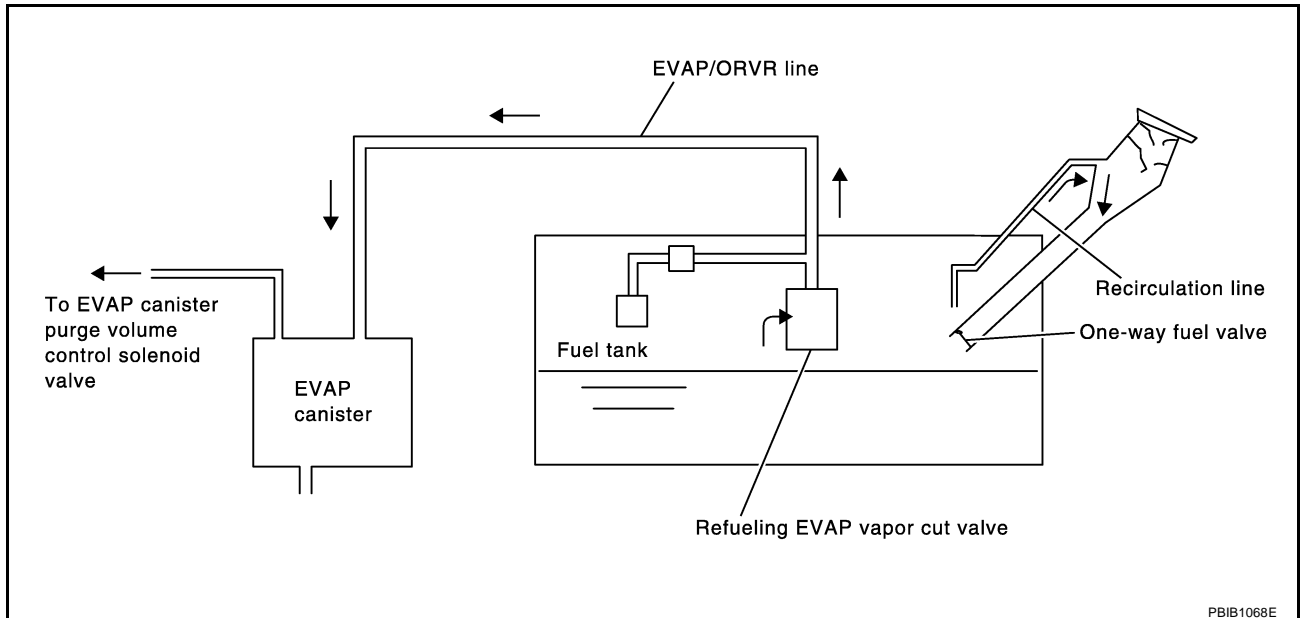

From the beginning of refueling, the air and vapor inside the fuel tank go through refueling EVAP vapor cut valve and EVAP/ORVR line to the EVAP canister. The vapor is absorbed by the EVAP canister and the air is released to the atmosphere.

When the refueling has reached the full level of the fuel tank, the refueling EVAP vapor cut valve is closed and refueling is stopped because of auto shut-off. The vapor which was absorbed by the EVAP canister is purged during driving.

WARNING:

When conducting inspections below, be sure to observe the following:

- Put a "CAUTION: INFLAMMABLE" sign in workshop.
- Do not smoke while servicing fuel system. Keep open flames and sparks away from work area.
- Be sure to furnish the workshop with a CO₂ fire extinguisher.

CAUTION:

- Before removing fuel line parts, carry out the following procedures:
 - Put drained fuel in an explosion-proof container and put lid on securely.
 - Release fuel pressure from fuel line. Refer to [EC-700. "FUEL PRESSURE RELEASE"](#).
 - Disconnect battery ground cable.
- Always replace O-ring when the fuel gauge retainer is removed.
- Do not kink or twist hose and tube when they are installed.
- Do not tighten hose and clamps excessively to avoid damaging hoses.
- After installation, run engine and check for fuel leaks at connection.
- Do not attempt to top off the fuel tank after the fuel pump nozzle shuts off automatically. Continued refueling may cause fuel overflow, resulting in fuel spray and possibly a fire.

Diagnostic Procedure

SYMPTOM: FUEL ODOR FROM EVAP CANISTER IS STRONG

1. CHECK EVAP CANISTER

1. Remove EVAP canister with EVAP canister vent control valve and EVAP control system pressure sensor attached.
2. Weigh the EVAP canister with EVAP canister vent control valve and EVAP control system pressure sensor attached.
The weight should be less than 2.1 kg (4.6 lb).

OK or NG

- OK >> GO TO 2.
NG >> GO TO 3.

2. CHECK IF EVAP CANISTER SATURATED WITH WATER

Does water drain from the EVAP canister?

Yes or No

- Yes >> GO TO 3.
No >> GO TO 5.

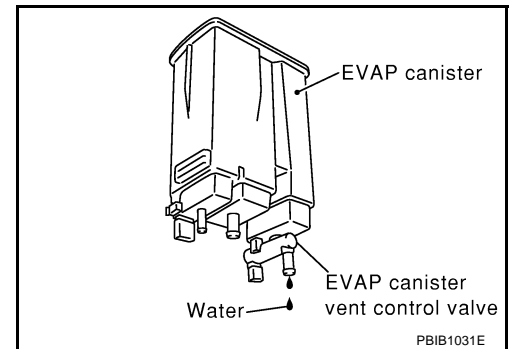

3. REPLACE EVAP CANISTER

Replace EVAP canister with a new one.

>> GO TO 4.

4. DETECT MALFUNCTIONING PART

Check the EVAP hose between EVAP canister and vehicle frame for clogging or poor connection.

>> Repair or replace EVAP hose.

5. CHECK REFUELING EVAP VAPOR CUT VALVE

Refer to [EC-1330, "Component Inspection"](#).

OK or NG

- OK >> **INSPECTION END**
NG >> Replace refueling EVAP vapor cut valve with fuel tank.

SYMPTOM: CANNOT REFUEL/FUEL ODOR FROM THE FUEL FILLER OPENING IS STRONG WHILE REFUELING

1. CHECK EVAP CANISTER

1. Remove EVAP canister with EVAP canister vent control valve and EVAP control system pressure sensor attached.
2. Weigh the EVAP canister with EVAP canister vent control valve and EVAP control system pressure sensor attached.
The weight should be less than 2.1 kg (4.6 lb).

OK or NG

- OK >> GO TO 2.
NG >> GO TO 3.

2. CHECK IF EVAP CANISTER SATURATED WITH WATER

Does water drain from the EVAP canister?

Yes or No

- Yes >> GO TO 3.
No >> GO TO 5.

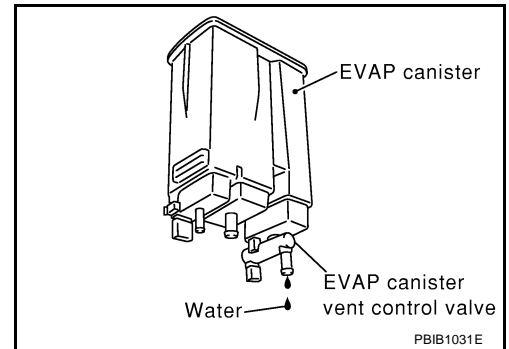

3. REPLACE EVAP CANISTER

Replace EVAP canister with a new one.

>> GO TO 4.

4. DETECT MALFUNCTIONING PART

Check the EVAP hose between EVAP canister and vehicle frame for clogging or poor connection.

>> Repair or replace EVAP hose.

5. CHECK VENT HOSES AND VENT TUBES

Check hoses and tubes between EVAP canister and refueling control valve for clogging, kink, looseness and improper connection.

OK or NG

- OK >> GO TO 6.
NG >> Repair or replace hoses and tubes.

6. CHECK FILLER NECK TUBE

Check recirculation line for clogging, dents and cracks.

OK or NG

- OK >> GO TO 7.
NG >> Replace filler neck tube.

7. CHECK REFUELING EVAP VAPOR CUT VALVE

Refer to [EC-1330, "Component Inspection"](#) .

OK or NG

- OK >> GO TO 8.
- NG >> Replace refueling EVAP vapor cut valve with fuel tank.

8. CHECK FUEL FILLER TUBE

Check filler neck tube and hose connected to the fuel tank for clogging, dents and cracks.

OK or NG

- OK >> GO TO 9.
- NG >> Replace fuel filler tube.

9. CHECK ONE-WAY FUEL VALVE-I

Check one-way valve for clogging.

OK or NG

- OK >> GO TO 10.
- NG >> Repair or replace one-way fuel valve with fuel tank.

10. CHECK ONE-WAY FUEL VALVE-II

1. Make sure that fuel is drained from the tank.
2. Remove fuel filler tube and hose.
3. Check one-way fuel valve for operation as follows.
When a stick is inserted, the valve should open, when removing stick it should close.

Do not drop any material into the tank.

OK or NG

- OK >> **INSPECTION END**
- NG >> Replace fuel filler tube or replace one-way fuel valve with fuel tank.

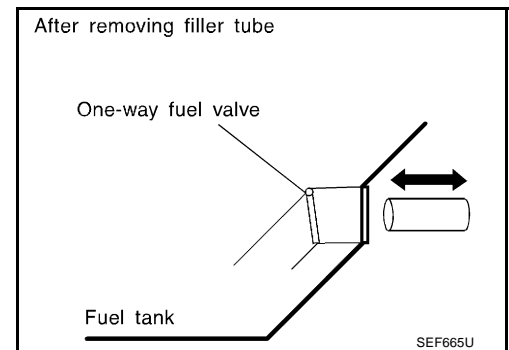

Component Inspection REFUELING EVAP VAPOR CUT VALVE

Ⓟ **With CONSULT-II**

1. Remove fuel tank. Refer to [FL-10, "FUEL TANK"](#) .
2. Drain fuel from the tank as follows:
 - a. Remove fuel feed hose located on the fuel gauge retainer.
 - b. Connect a spare fuel hose, one side to fuel gauge retainer where the hose was removed and the other side to a fuel container.
 - c. Drain fuel using "FUEL PUMP RELAY" in "ACTIVE TEST" mode with CONSULT-II.
3. Check refueling EVAP vapor cut valve for being stuck to close as follows.
Blow air into the refueling EVAP vapor cut valve (from the end of EVAP/ORVR line hose), and check that the air flows freely into the tank.
4. Check refueling EVAP vapor cut valve for being stuck to open as follows.
 - a. Connect vacuum pump to hose end.
 - b. Remove fuel gauge retainer with fuel gauge unit.
Always replace O-ring with new one.
 - c. Put fuel tank upside down.

ABS00CFX

ON BOARD REFUELING VAPOR RECOVERY (ORVR)

[VK45DE]

- d. Apply vacuum pressure to hose end [-13.3 kPa (-100 mmHg, -3.94 inHg)] with fuel gauge retainer remaining open and check that the pressure is applicable.

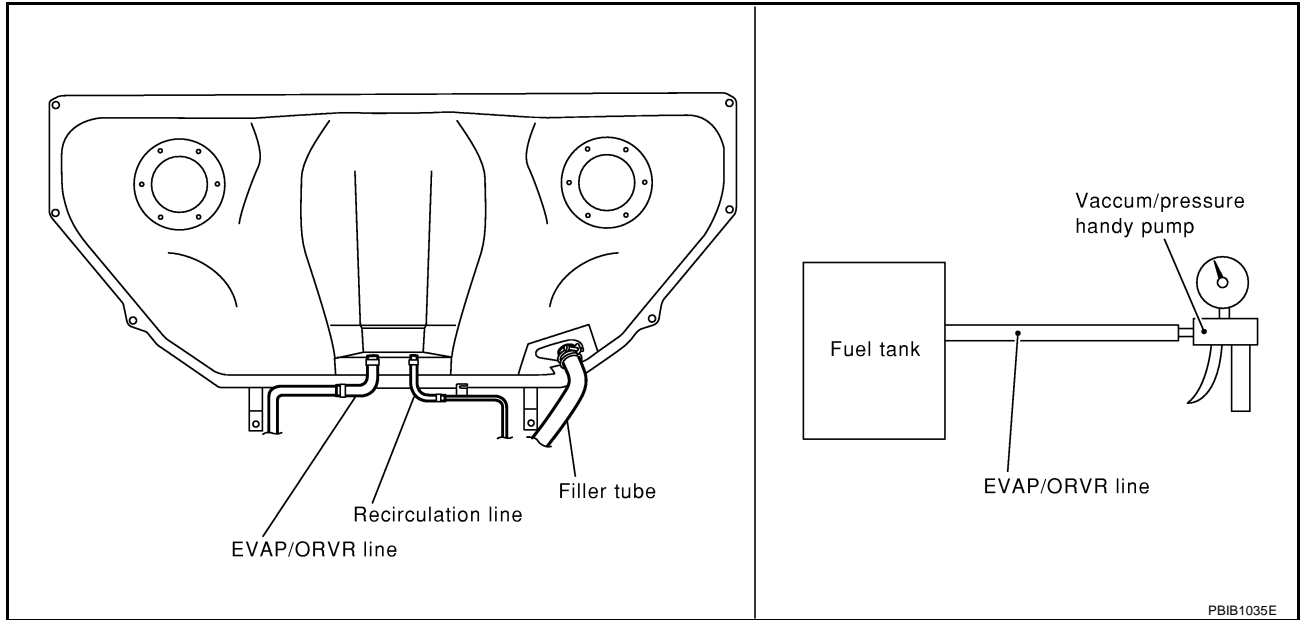

⊗ Without CONSULT-II

1. Remove fuel tank. Refer to [FL-10, "FUEL TANK"](#).
2. Drain fuel from the tank as follows:
 - a. Remove fuel gauge retainer.
 - b. Drain fuel from the tank using a handy pump into a fuel container.
3. Check refueling EVAP vapor cut valve for being stuck to close as follows. Blow air into the refueling EVAP vapor cut valve (from the end of EVAP/ORVR line hose), and check that the air flows freely into the tank.
4. Check refueling EVAP vapor cut valve for being stuck to open as follows.
 - a. Connect vacuum pump to hose end.
 - b. Remove fuel gauge retainer with fuel gauge unit.
Always replace O-ring with new one.
 - c. Put fuel tank upside down.
- d. Apply vacuum pressure to hose end [-13.3 kPa (-100 mmHg, -3.94 inHg)] with fuel gauge retainer remaining open and check that the pressure is applicable.

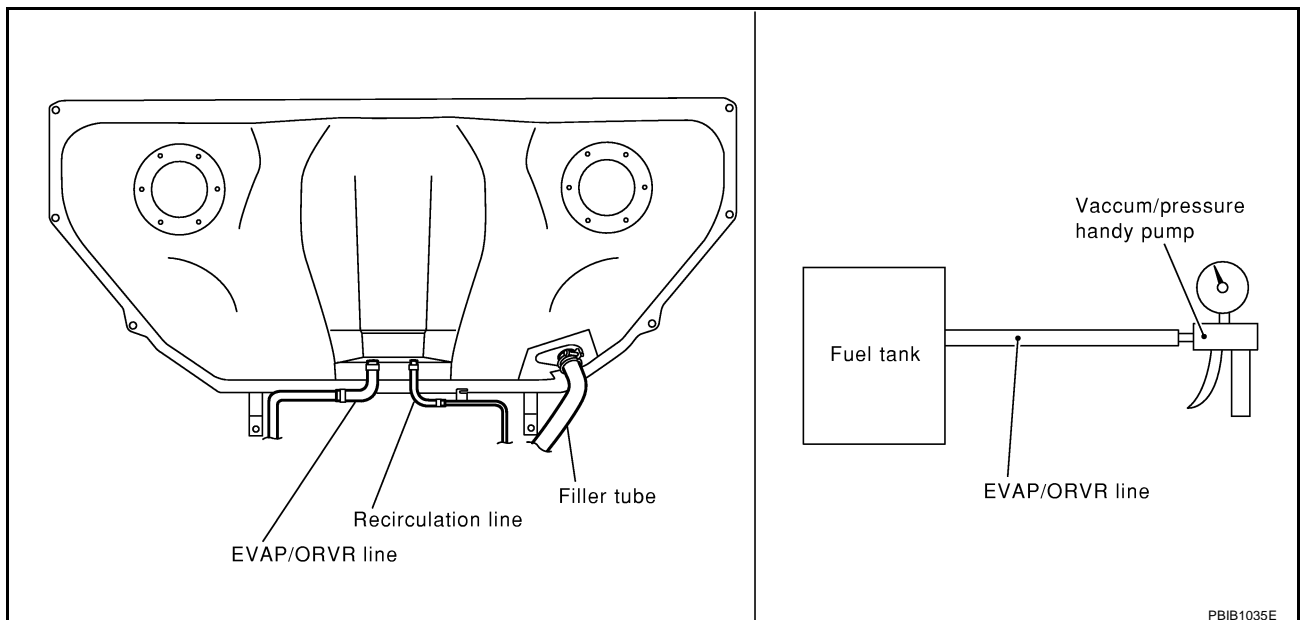

POSITIVE CRANKCASE VENTILATION

PFP:11810

Description SYSTEM DESCRIPTION

ABS00CFY

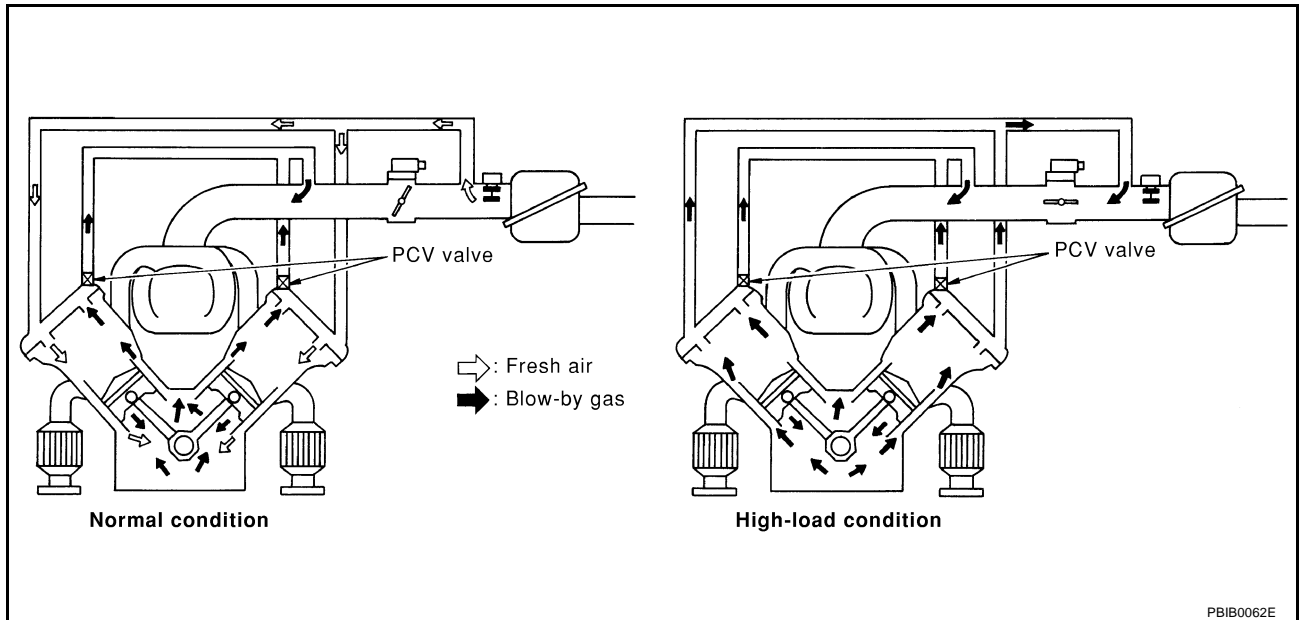

PBIB0062E

This system returns blow-by gas to the intake manifold.

The positive crankcase ventilation (PCV) valve is provided to conduct crankcase blow-by gas to the intake manifold.

During partial throttle operation of the engine, the intake manifold sucks the blow-by gas through the PCV valve.

Normally, the capacity of the valve is sufficient to handle any blow-by and a small amount of ventilating air.

The ventilating air is then drawn from the air inlet tubes into the crankcase. In this process the air passes through the hose connecting air inlet tubes to rocker cover.

Under full-throttle condition, the manifold vacuum is insufficient to draw the blow-by flow through the valve. The flow goes through the hose connection in the reverse direction.

On vehicles with an excessively high blow-by, the valve does not meet the requirement. This is because some of the flow will go through the hose connection to the air inlet tubes under all conditions.

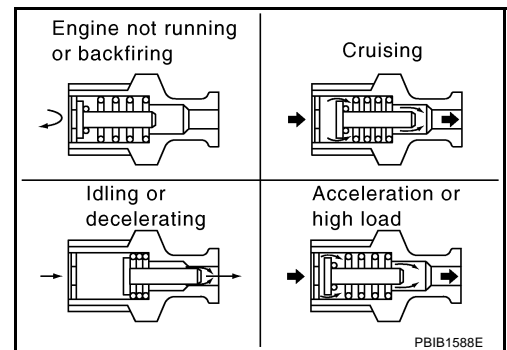

PBIB1588E

Component Inspection PCV (POSITIVE CRANKCASE VENTILATION) VALVE

ABS00CFZ

With engine running at idle, remove PCV valve from rocker cover. A properly working valve makes a hissing noise as air passes through it. A strong vacuum should be felt immediately when a finger is placed over valve inlet.

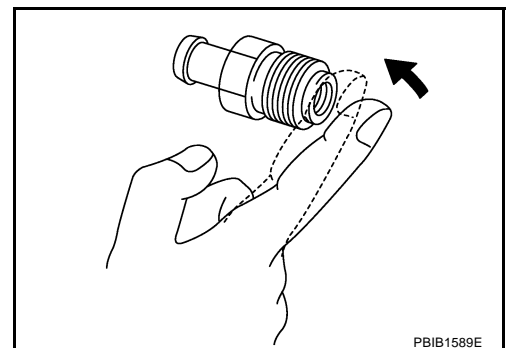

PBIB1589E

PCV VALVE VENTILATION HOSE

1. Check hoses and hose connections for leaks.
2. Disconnect all hoses and clean with compressed air. If any hose cannot be freed of obstructions, replace.

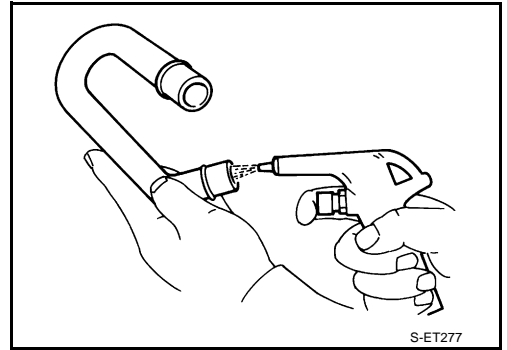

A

EC

C

D

E

F

G

H

I

J

K

L

M

AUTOMATIC SPEED CONTROL DEVICE (ASCD)

PFP:18930

System Description INPUT/OUTPUT SIGNAL CHART

ABS00CG0

Sensor	Input signal to ECM	ECM function	Actuator
ASCD brake switch	Brake pedal operation	ASCD vehicle speed control	Electric throttle control actuator
Stop lamp switch	Brake pedal operation		
ASCD steering switch	ASCD steering switch operation		
Park/Neutral position (PNP) switch	Gear position		
Unified meter and A/C amp.*	Vehicle speed		
TCM*	Powertrain revolution		

*: This signal is sent to the ECM through CAN communication line.

BASIC ASCD SYSTEM

Refer to Owner's Manual for ASCD operating instructions.

Automatic Speed Control Device (ASCD) allows a driver to keep vehicle at predetermined constant speed without pressing accelerator pedal. Driver can set vehicle speed in advance between approximately 40 km/h (25 MPH) and 144 km/h (89 MPH).

ECM controls throttle angle of electric throttle control actuator to regulate engine speed.

Operation status of ASCD is indicated by CRUISE indicator and SET indicator in combination meter. If any malfunction occurs in ASCD system, it automatically deactivates control.

SET OPERATION

Press ON/OFF (MAIN) switch. (The CRUISE indicator in combination meter illuminates.)

When vehicle speed reaches a desired speed between approximately 40 km/h (25 MPH) and 144 km/h (89 MPH), press COAST/SET switch. (Then SET indicator in combination meter illuminates.)

ACCEL OPERATION

If the ACCEL/RESUME switch is pressed during cruise control driving, increase the vehicle speed until the switch is released or vehicle speed reaches maximum speed controlled by the system.

And then ASCD will keep the new set speed.

CANCEL OPERATION

When any of following conditions exist, cruise operation will be canceled.

- CANCEL switch is pressed
- More than 2 switches at ASCD steering switch are pressed at the same time (Set speed will be cleared)
- Brake pedal is depressed
- Selector lever is changed to N, P, R position
- Vehicle speed decreased to 13 km/h (8 MPH) lower than the set speed
- VDC/TCS system is operated

When the ECM detects any of the following conditions, the ECM will cancel the cruise operation and inform the driver by blinking indicator lamp.

- Engine coolant temperature is slightly higher than the normal operating temperature, CRUISE lamp may blink slowly.
When the engine coolant temperature decreases to the normal operating temperature, CRUISE lamp will stop blinking and the cruise operation will be able to work by pressing COAST/SET switch or ACCEL/RESUME switch.
- Malfunction for some self-diagnoses regarding ASCD control: SET lamp will blink quickly.

If ON/OFF (MAIN) switch is turned to OFF during ASCD is activated, all of ASCD operations will be canceled and vehicle speed memory will be erased.

COAST OPERATION

When the COAST/SET switch is pressed during cruise control driving, decrease vehicle set speed until the switch is released. And then ASCD will keep the new set speed.

RESUME OPERATION

When the ACCEL/RESUME switch is pressed after cancel operation other than pressing ON/OFF (MAIN) switch is performed, vehicle speed will return to last set speed. To resume vehicle set speed, vehicle condition must meet following conditions.

- Brake pedal is released
- A/T selector lever is in other than P and N positions
- Vehicle speed is greater than 40 km/h (25 MPH) and less than 144 km/h (89 MPH)

Component Description

ASCD STEERING SWITCH

Refer to [EC-1181](#) .

ASCD BRAKE SWITCH

Refer to [EC-1199](#) , and [EC-1302](#) .

STOP LAMP SWITCH

Refer to [EC-1199](#) , [EC-1220](#) and [EC-1302](#) .

ELECTRIC THROTTLE CONTROL ACTUATOR

Refer to [EC-1077](#) , [EC-1079](#) , [EC-1085](#) and [EC-1090](#) .

ASCD INDICATOR

Refer to [EC-1309](#) .

ABS00CG1

A
EC
C
D
E
F
G
H
I
J
K
L
M

SERVICE DATA AND SPECIFICATIONS (SDS)

PFP:00030

Fuel Pressure

ABS00CG2

Fuel pressure at idling kPa (kg/cm ² , psi)	Approximately 350 (3.57, 51)
--	------------------------------

Idle Speed and Ignition Timing

ABS00CG3

Target idle speed	No-load* ¹ (in P or N position)	650±50 rpm
Air conditioner: ON	In P or N position	700 rpm or more
Ignition timing	In P or N position	12° ± 5° BTDC

*1: Under the following conditions:

- Air conditioner switch: OFF
- Electric load: OFF (Lights, heater fan & rear window defogger)
- Steering wheel: Kept in straight-ahead position

Calculated Load Value

ABS00CG4

Condition	Calculated load value% (Using CONSULT-II or GST)
At idle	14.0 - 33.0
At 2,500 rpm	12.0 - 25.0

Mass Air Flow Sensor

ABS00CG5

Supply voltage	Battery voltage (11 - 14V)
Output voltage at idle	1.2 - 1.8V*
Mass air flow (Using CONSULT-II or GST)	2.0 - 6.0 g·m/sec at idle* 7.0 - 20.0 g·m/sec at 2,500 rpm*

*: Engine is warmed up to normal operating temperature and running under no-load.

Intake Air Temperature Sensor

ABS00CG6

Temperature °C (°F)	Resistance kΩ
25 (77)	1.9 - 2.1
80 (176)	0.31 - 0.37

Engine Coolant Temperature Sensor

ABS00CG7

Temperature °C (°F)	Resistance kΩ
20 (68)	2.1 - 2.9
50 (122)	0.68 - 1.00
90 (194)	0.236 - 0.260

Heated Oxygen Sensor 1 Heater

ABS00CG8

Resistance [at 25°C (77°F)]	3.3 - 4.0Ω
-----------------------------	------------

Heated Oxygen Sensor 2 Heater

ABS00CG9

Resistance [at 25°C (77°F)]	5.0 - 7.0Ω
-----------------------------	------------

Crankshaft Position Sensor (POS)

ABS00CGA

Refer to [EC-964, "Component Inspection"](#) .

Camshaft Position Sensor (PHASE)

ABS00CGB

Refer to [EC-970, "Component Inspection"](#) .

Throttle Control Motor

ABS00CGC

Resistance [at 25°C (77°F)]	Approximately 1 - 15Ω
-----------------------------	-----------------------

SERVICE DATA AND SPECIFICATIONS (SDS)

[VK45DE]

Injector

ABS00CGD

Resistance [at 10 - 60°C (50 - 140°F)]

13.5 - 17.5Ω

Fuel Pump

ABS00CGE

Resistance [at 25°C (77°F)]

Approximately 0.2 - 5.0Ω

A

EC

C

D

E

F

G

H

I

J

K

L

M

